

1 Features

- Multi GNSS solution for embedded applications
- High Efficiency to size ratio
- Design for use with no ground beneath the antenna
- Near omni-directional characteristics enable good performance for any device
- Designed for SMD mounting
- Low profile, small footprint, light weight
- Supplied in tape on reel

2 Description

Brevis-GNSS is intended for use with multi GNSS bands. These include GPS, GLONASS, GALILEO and Beidou.

The antenna uses a ground plane in order to radiate efficiently, but this ground plane must not extend underneath the antenna itself.

The antenna has RHCP characteristics suitable for GNSS signals.

3 Applications

- Small mobile handheld devices with any GNSS receivers.
- Application specific tracking devices.
- Location accessories: SDIO cards, PCMCIA cards.

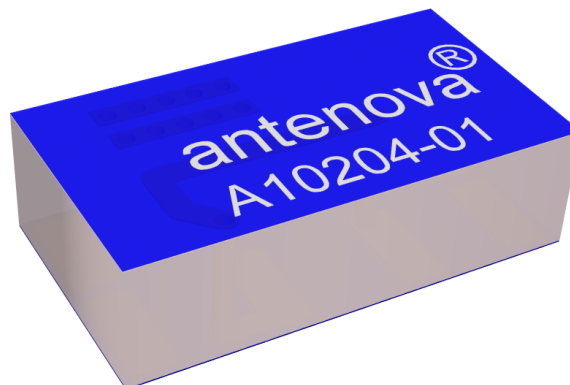

4 Part number

Brevis-GNSS: A10204-01



5 General data

Product name	Brevis-GNSS
Part Number	A10204-01
Frequency	1559-1609MHz
Polarization	Linear
Operating temperature	-40 °C to +140 °C
Environmental condition test	ISO16750-4 5.1.1.1/5.1.2.1/5.3.2
Impedance with matching	50 Ω
Weight	<0.2g
Antenna type	SMD
Dimensions	11.0 x 6.0 x 3.2 [mm]
Footprint Size	11.0 x 6.0 [mm]

6 Electrical characteristics

	Typical performance	Conditions
Peak gain	0.5 dBi	All data measured on Antenna's reference board, part number A10204-U2
Average gain	0.25 dBi	
Average efficiency	50%	
Maximum Return Loss	-10 dB	
Maximum VSWR	1.9:1	

7 Electrical performance

7-1 Return Loss

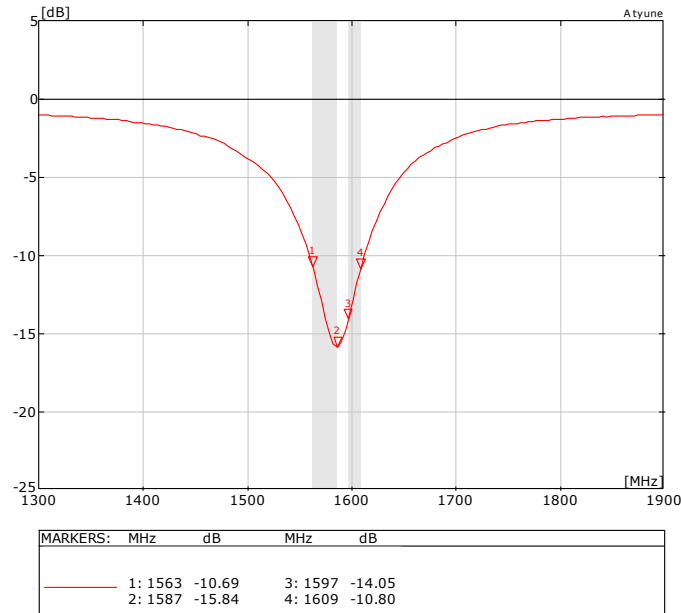

7-2 VSWR

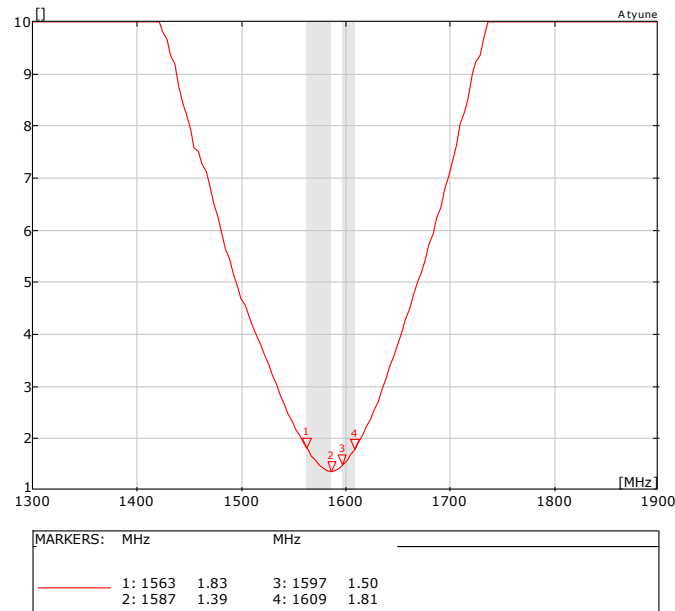

7-3 Antenna patterns

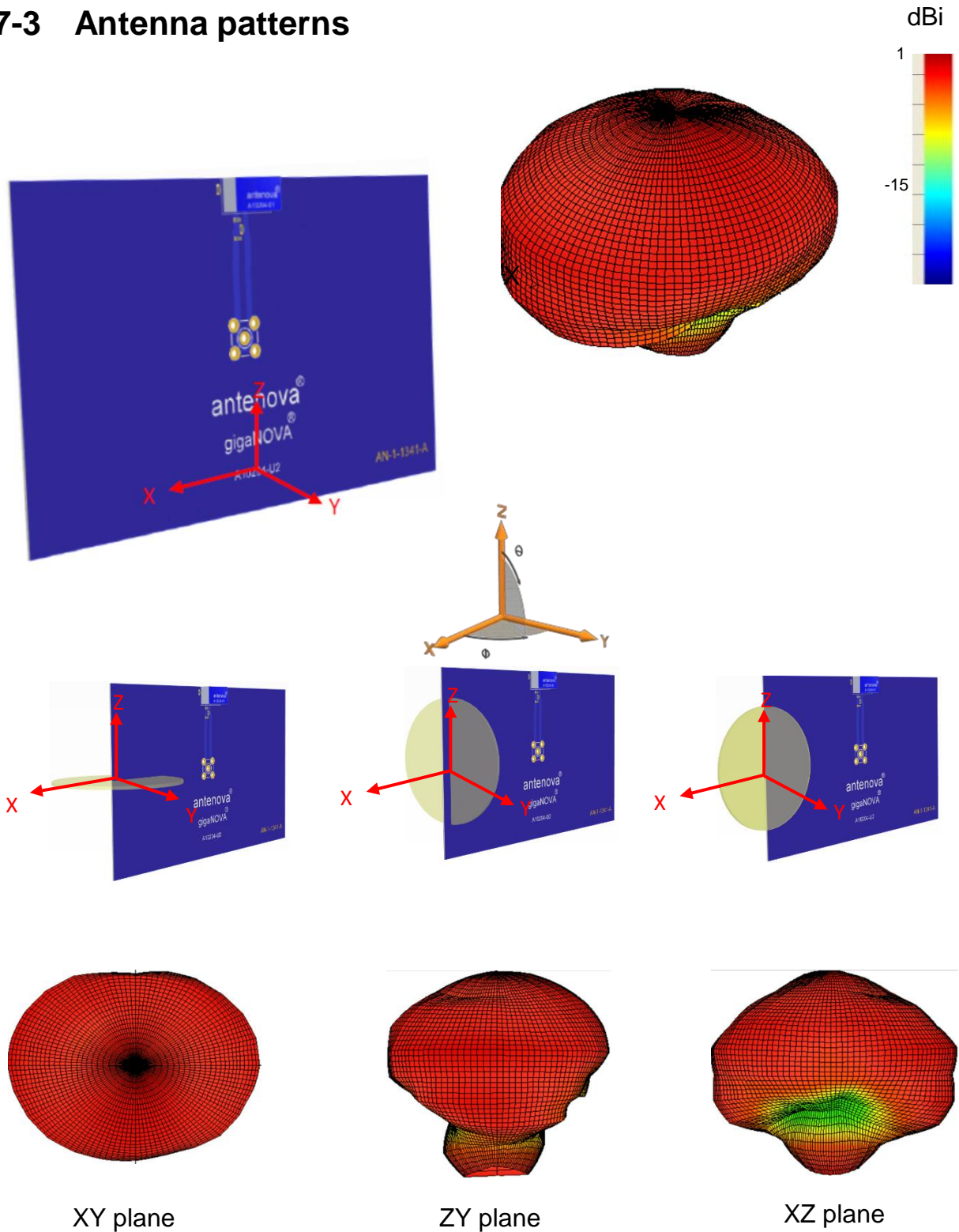

Patterns show combined polarisations
measured on reference board A10381-U2

7-3 Antenna patterns

The typical radiation pattern of the Brevis-GNSS A10204-01 GPS antenna has been measured in Antenova's "Active GPS" chamber, using Antenova's standard RF module based on MTK3337 IC combined with two stages of Saw Filters.

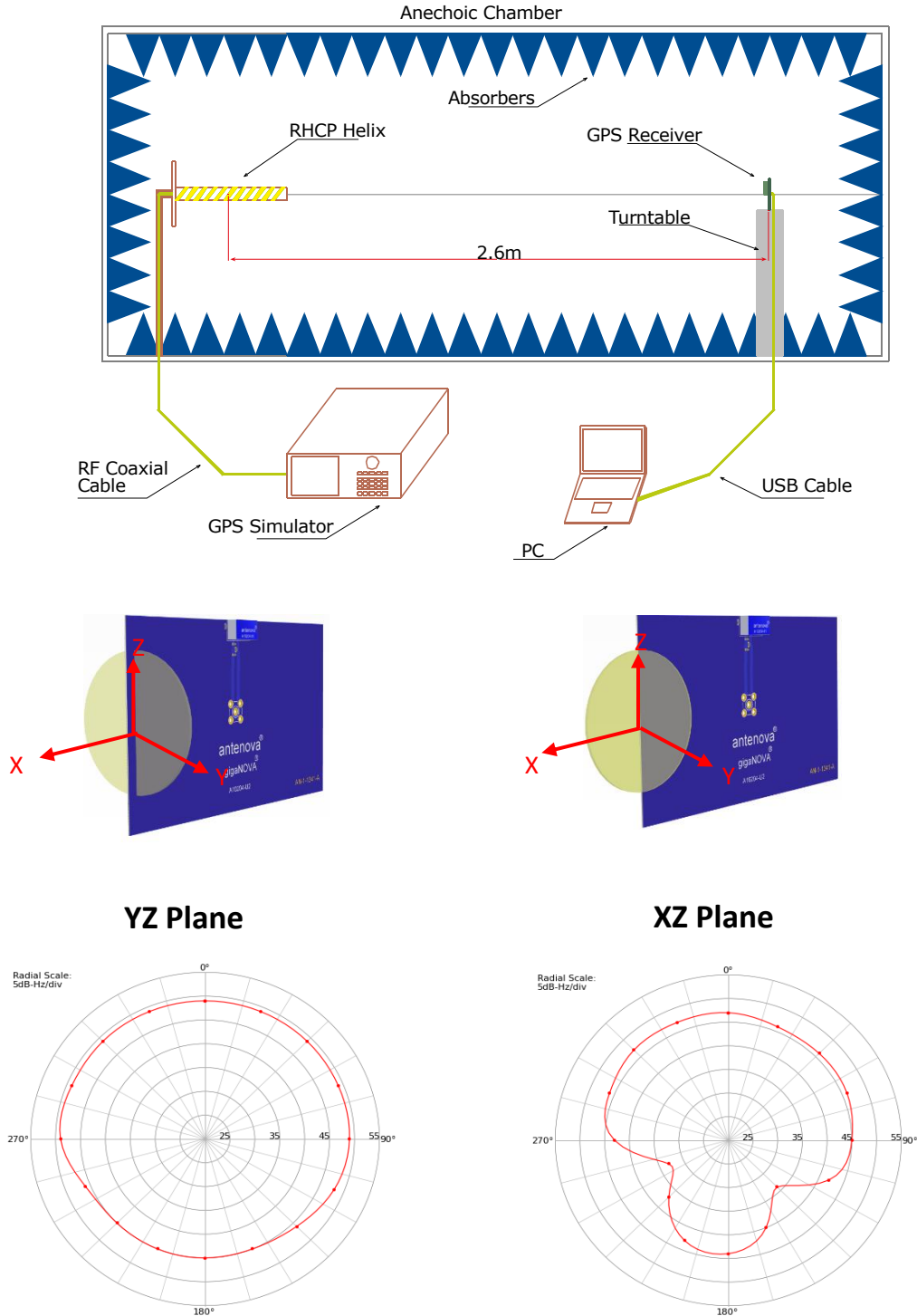

8 Antenna dimensions

Brevis-GNSS

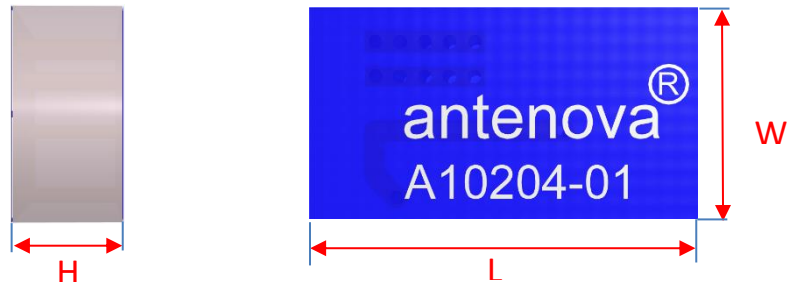

L	W	H
Length	Width	Height
11.0 ± 0.1	6.0 ± 0.1	3.2 ± 0.1

Dimensions in mm

9 Antenna footprint

Brevis-GNSS (Part No: A10204-01)

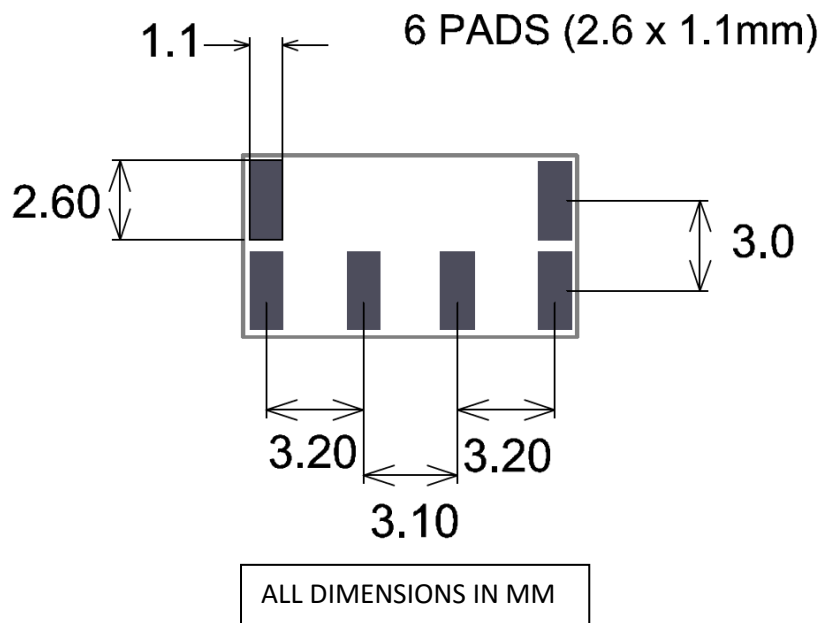

* CAD files of the antenna footprint are available to download from
www.antenna-m2m.com

10 Electrical interface

10-1 Transmission lines

- All transmission lines should be designed to have a characteristic impedance of 50Ω
- The length of the transmission lines should be kept to a minimum
- Any other parts of the RF system like transceivers, power amplifiers, etc, should also be designed to have an impedance of 50Ω

Once the material for the PCB has been chosen (PCB thickness and dielectric constant), a coplanar transmission line can easily be designed using any of the commercial software packages for transmission line design. For the chosen PCB thickness, copper thickness and substrate dielectric constant, the program will calculate the appropriate transmission line width and gaps on either side of the track so the characteristic impedance of the coplanar transmission line is 50Ω .

10-2 Clearance

The antenna requires a clearance on the host PCB. With exception of the footprint pads the area shown below should be kept clear from all copper. No tracks or copper planes must be placed within this area. Any deviation from the advised layout shown below will result in a loss in the antenna performance. It is best that the copper track layout is imported from CAD files which are available from Antenova M2M on request. Please contact sales@antenova-m2m.com for further details.

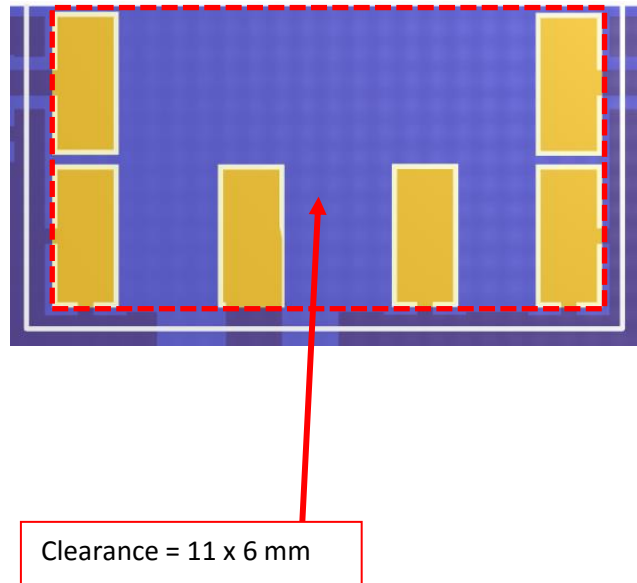

10-3 Matching circuit

The antenna requires a matching circuit that must be optimized for each customer's product. The matching circuit will require up to three components (0402 size), and an additional tuning element is also required (0402 size) the following pad layout should be designed into the device so the correct circuit can be installed.

Note: The tuning element by default is a 0402 zero ohm resistor

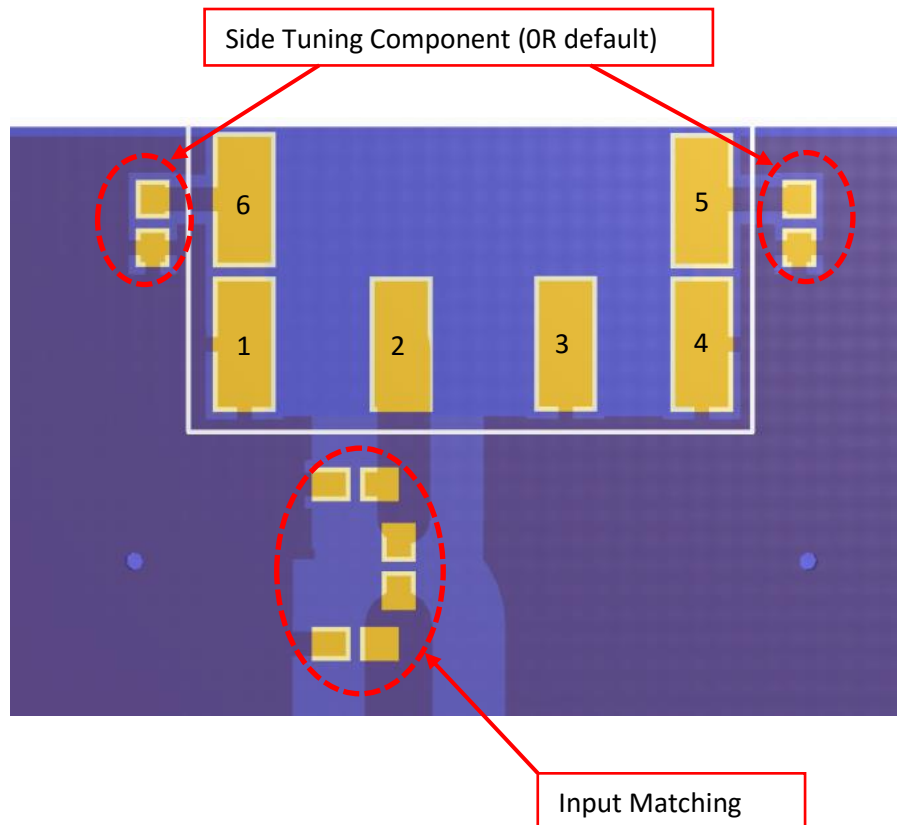

In addition to the matching circuit, a separate DC blocking capacitor will also be required between the radio and the antenna matching circuit.

Note: The component values for the matching circuit will vary depending on the size of the PCB and surrounding components. The impedance of the antenna should be measured before selecting suitable matching components. Antenova M2M offers this service on request.

10-4 Matching circuit (Schematic)

The electrical circuit for the antenna matching is shown here. The values are dependent on the device. C2 and C3 are default to 0R resistors.

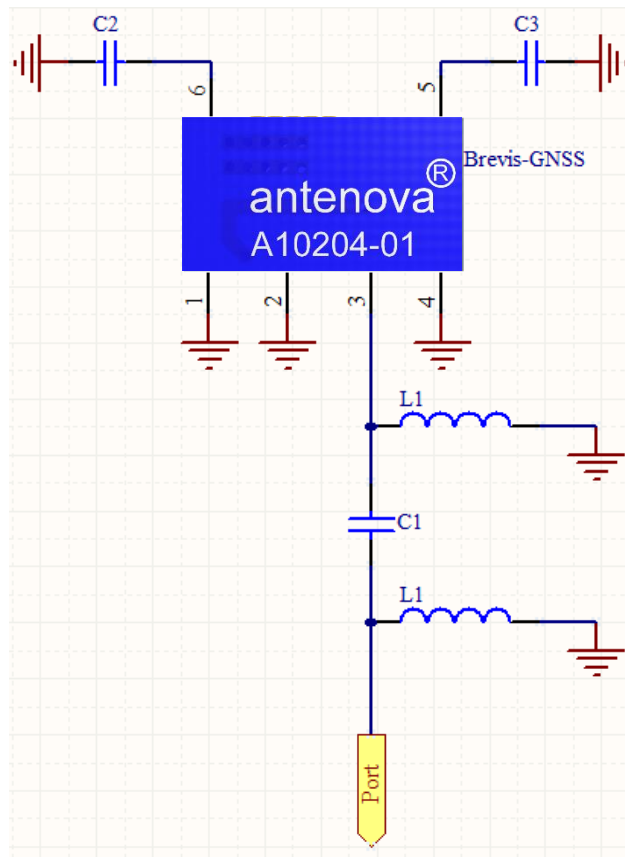

Contact sales@antenoVA-m2m.com for further information.

10-5 Antenna placement

Antenova M2M strongly recommends placing the antenna near the edge of the board. Maximum antenna performance is achieved by placing the antenna towards the middle of the PCB, as shown in the diagram below. Other configurations are possible but recommend contacting Antenova for advice on any other antenna placement options.

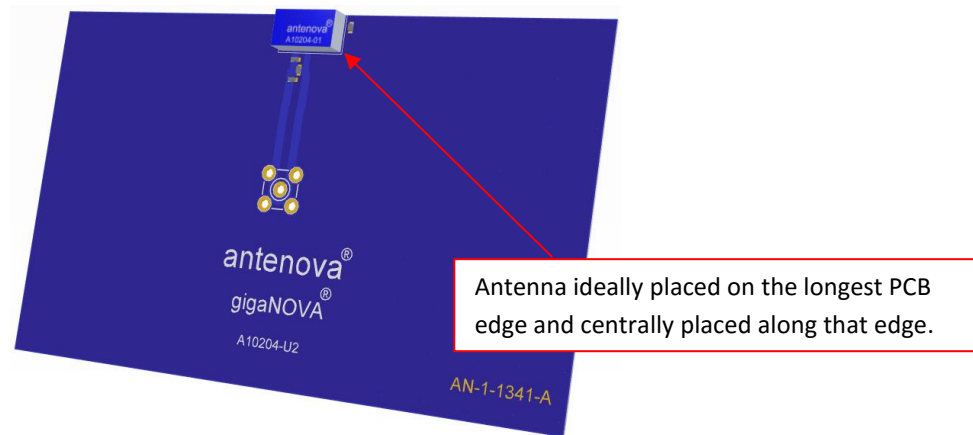

- The antenna top edge must be placed level with the edge of the host PCB.
- The minimum length of the host PCB should be no less than 40mm.

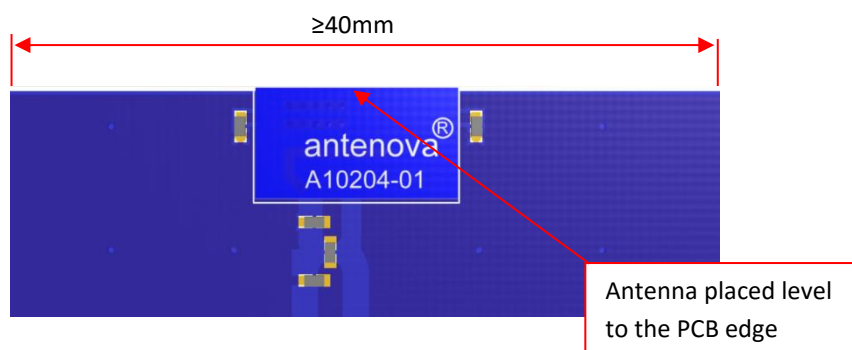

- Central placement of the antenna is advised. However, an offset placement is also possible.
- The antenna must be placed no closer to a PCB side than 10mm.



- The minimum PCB size for the antenna should be no smaller than 40mm X 30mm
- Additional electronic components near the antenna should be at a distance of at least 2 mm away from the ground plane edges. The antenna should also be clear of ground from both the top surface of the antenna and below the antenna.

10-6 Wearable Application Guidance

The antenna can be used for wearable applications. A minimum distance must be maintained between the antenna and the human body.

- Watch Application (PCB Radius 20mm)
- Minimum distance to human body shown below.

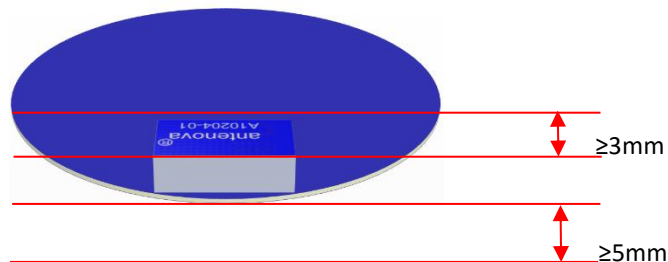

- The device case will act as the spacer to keep the antenna from going below the minimum distance.

Note: The RF front end of the receiver will determine the overall performance. To ensure optimum device performance Antenova can review the device schematic and layout for the relevant GNSS sections. Please contact Antenova M2M for more information.

10-7 Reference board

The reference board has been designed for evaluation purposes of Brevis-GNSS and it includes a SMA female connector

Brevis-GNSS A10204-U2 Reference Board



Dimensions in mm

To order a reference board contact sales@antenna-m2m.com

11 Soldering

This antenna is suitable for lead free soldering.

The reflow profile should be adjusted to suit the device, oven and solder paste, while observing the following conditions:

- The maximum temperature should not exceed 240 °C
- However for lead free soldering, a maximum temperature of 255 °C for no more than 20 seconds is permitted.
- The antenna should not be exposed to temperatures exceeding 120 °C more than 3 times during the soldering process.

12 Hazardous material regulation conformance

The antenna has been tested to conform to RoHS requirements. A certificate of conformance is available from Antenova M2M's website.

13 Packaging

13-1 Optimal storage conditions for packaged reels

Temperature	-10°C to 40°C
Humidity	Less than 75% RH
Shelf Life	18 Months
Storage place	Away from corrosive gas and direct sunlight
Packaging	Reels should be stored in unopened sealed manufacturer's plastic packaging.

Note: Storage of open reels of antennas is not recommended due to possible oxidization of pads on antennas. If short term storage is necessary, then it is highly recommended that the bag containing the antenna reel is re-sealed and stored in like storage conditions as in above table.

13-2 Tape characteristics

W	F	E1	P0	P1	P2	A0	B0	K0	SO	T	D0
24+/- 0.3	11.5+/- 0.1	1.75+/- 0.1	4+/- 0.1	12+/- 0.1	2+/- 0.1	6.4+/- 0.1	11.4+/- 0.1	3.6+/- 0.1	23+/- 0.1	0.4+/- 0.1	1.5+/- 0.1

Quantity	Leading Space	Trailing Space
1000 pcs/reel	35 blank antenna holders	35 blank antenna holders

13-3 Reel dimensions

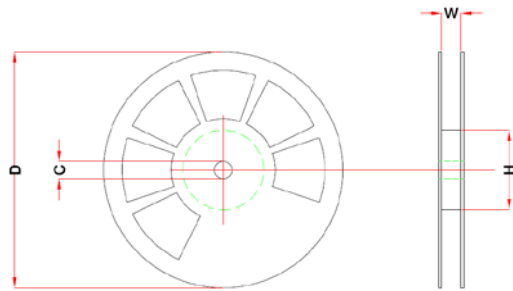

Width (W)	Reel Diameter (D)	Hub Diameter (H)	Shaft Diameter (C)
24.75mm	330+/-2.0mm	98.4mm	13+/-0.5mm

13-4 Box dimensions

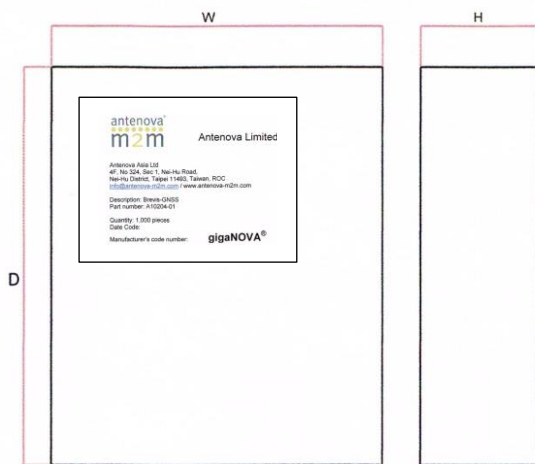

Width W	Breadth B	Thickness H
375mm	355mm	70mm

13-5 Bag properties

Reels are supplied in a vacuum sealed ESD aluminium bag.

13-6 Reel label information

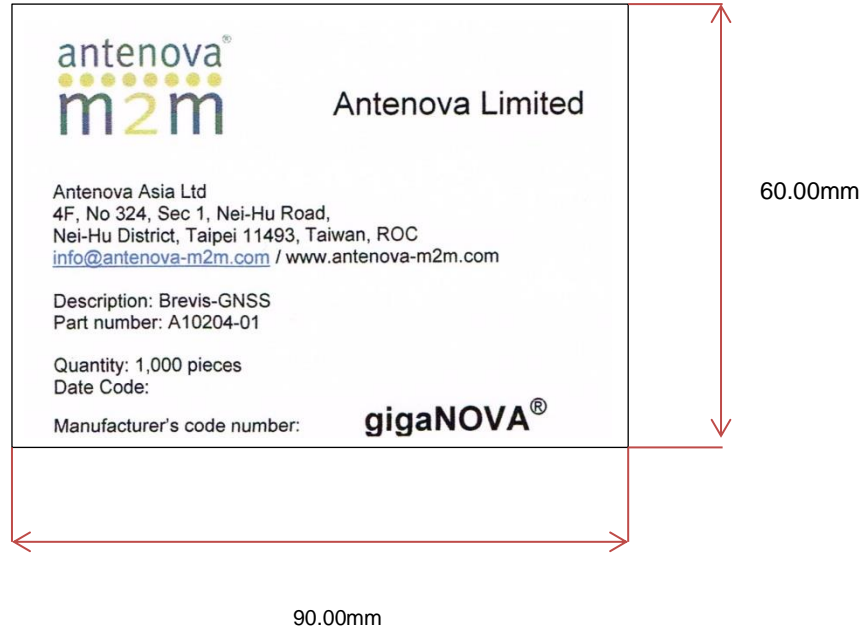



www.antenova-m2m.com

Corporate Headquarters

Antenova Limited
2nd Floor, Titan Court
3 Bishop Square
Hatfield
AL10 9NA

North America Headquarters

Antenova Limited
100 Brush Creek Road, Suite 103
Santa Rosa
California, 95404
USA

Asia Headquarters

Antenova Asia Limited
4F, No. 324, Sec. 1, Nei-Hu Road
Nei-Hu District
Taipei 11493
Taiwan, ROC

Tel: +44 1223 810600

Email: sales@antenova-m2m.com

Tel: +1 707 890 5202

Email: sales@antenova-m2m.com

Tel: +886 (0) 2 8797 8630

Fax: +886 (0) 2 8797 6890

Email: sales@antenova-m2m.com

Copyright® Antenova Ltd. All Rights Reserved. Antenova®, Antenova M2M®, gigaNOVA®, the Antenova product family names, and the Antenova and Antenova M2M logos are trademarks and/or registered trademarks of Antenova Ltd. Any other names and/or trademarks belong to their respective companies.

The materials provided herein are believed to be reliable and correct at the time of print. Antenova does not warrant the accuracy or completeness of the information, text, graphics or other items contained within these information. Antenova further assumes no responsibility for the use of this information, and all such information shall be entirely at the user's risk.



Certificate No: 4598

Antennas for Wireless M2M Applications

Данный компонент на территории Российской Федерации

Вы можете приобрести в компании MosChip.

Для оперативного оформления запроса Вам необходимо перейти по данной ссылке:

<http://moschip.ru/get-element>

Вы можете разместить у нас заказ для любого Вашего проекта, будь то серийное производство или разработка единичного прибора.

В нашем ассортименте представлены ведущие мировые производители активных и пассивных электронных компонентов.

Нашей специализацией является поставка электронной компонентной базы двойного назначения, продукции таких производителей как XILINX, Intel (ex.ALTERA), Vicor, Microchip, Texas Instruments, Analog Devices, Mini-Circuits, Amphenol, Glenair.

Сотрудничество с глобальными дистрибьюторами электронных компонентов, предоставляет возможность заказывать и получать с международных складов практически любой перечень компонентов в оптимальные для Вас сроки.

На всех этапах разработки и производства наши партнеры могут получить квалифицированную поддержку опытных инженеров.

Система менеджмента качества компании отвечает требованиям в соответствии с ГОСТ Р ИСО 9001, ГОСТ РВ 0015-002 и ЭС РД 009

Офис по работе с юридическими лицами:

105318, г.Москва, ул.Щербаковская д.3, офис 1107, 1118, ДЦ «Щербаковский»

Телефон: +7 495 668-12-70 (многоканальный)

Факс: +7 495 668-12-70 (доб.304)

E-mail: info@moschip.ru

Skype отдела продаж:

moschip.ru

moschip.ru_4

moschip.ru_6

moschip.ru_9