

SF2025B

**259.861 MHz
SAW Filter**

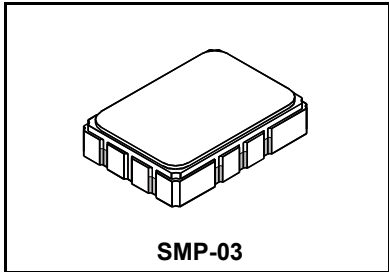

- *Designed for SDARS Receiver IF Application*
- *Low Insertion Loss*
- *5.0 X 7.0 mm Surface-Mount Case*
- *Differential Input and Output*
- *Complies with Directive 2002/95/EC (RoHS)*



Absolute Maximum Ratings

Rating	Value	Units
Maximum Incident Power in Passband	+10	dBm
Max. DC voltage between any 2 terminals	30	VDC
Storage Temperature Range	-40 to +105	°C
Suitable for lead-free soldering - Max Soldering Temperature	260°C for 30 s	

Electrical Characteristics

Characteristic	Sym	Notes	Min	Typ	Max	Units	
Nominal Center Frequency	f_c	1	259.861			MHz	
Passband	Minimum Insertion Loss	IL		13.3	15.5	dB	
		1.5 dB Passband	BW _{1.5}	13.8			MHz
	3 dB Passband	BW ₃		14.5			
Amplitude Ripple from fc-6.354 MHz to fc-4.2885 MHz (-20 to 85°C)		1, 2			1	dB _{p-p}	
Amplitude Ripple from fc-6.354 MHz to fc-4.2885 MHz (-40 to -20°C)					1.5		
Amplitude Ripple from fc-4.4965 MHz to fc-2.431 MHz					1		
Amplitude Ripple from fc-2.639 MHz to fc+0.079 MHz					1		
Amplitude Ripple from fc-0.079 MHz to fc+2.639 MHz					1		
Amplitude Ripple from fc+2.431 MHz to fc+4.4965 MHz					1		
Amplitude Ripple from fc+4.2885 MHz to fc+6.354 MHz (-40 to 60°C)					1		
Amplitude Ripple from fc+4.2885 MHz to fc+6.354 MHz (60 to 85°C)					1.15		
Group Delay Variation over fc-6.354 MHz to fc-2.431 MHz and from fc+2.431 MHz to fc+6.354 MHz	GDV1	1, 2, 3		40	60	ns _{p-p}	
			Group Delay Variation over fc±2.639 MHz	GDV2	40		120
Rejection	fc-28 to fc-12 MHz and fc+12 to fc+33 MHz	1, 2, 3	36	43		dB	
			fc-12 to fc-10.5 MHz	30	40		
			fc+9 to fc+12 MHz	18	36		
Operating Temperature Range	T _A	1	-40		+85	°C	
Frequency Temperature Coefficient				-18		ppm/°C	
Differential Input and Output Impedance	L & C Match to 150 ohms						
Case Style		6	SMP-03 7 x 5 mm Nominal Footprint				
Lid Symbolization (YY=year, WW=week, S=shift) See note 4			RFM SF2025B YYWWS				

Electrical Connections

Connection	Terminals
Port 1 Hot	10
Port 1 Ground Return	1
Port 2 Hot	5
Port 2 Ground Return	6
Case Ground	All Others

Discontinued



CAUTION: Electrostatic Sensitive Device. Observe precautions for handling.

Notes:

1. Unless noted otherwise, all specifications apply over the operating temperature range with filter soldered to the specified demonstration board with impedance matching to 50 Ω and measured with 50 Ω network analyzer.
2. Unless noted otherwise, all frequency specifications are referenced to the nominal center frequency, fc.
3. Rejection is measured as attenuation below the minimum IL point in the passband. Rejection in final user application is dependent on PCB layout and external impedance matching design. See Application Note No. 42 for details.
4. "LRIP" or "L" after the part number indicates "low rate initial production" and "ENG" or "E" indicates "engineering prototypes."
5. The design, manufacturing process, and specifications of this filter are subject to change.
6. Tape and Reel Standard Per ANSI / EIA 481.
7. Either Port 1 or Port 2 may be used for either input or output in the design. However, impedances and impedance matching may vary between Port 1 and Port 2, so that the filter must always be installed in one direction per the circuit design.
8. US and international patents may apply.
9. Murata, stylized Murata logo, and Murata N.A., Inc. are registered trademarks of Murata Manufacturing Co., Ltd.

CH1 S11 1 UFS 1: 40.799 3.3672 2.0623 nH 259.861000 MHz

hp

Cor

PRm

HLd

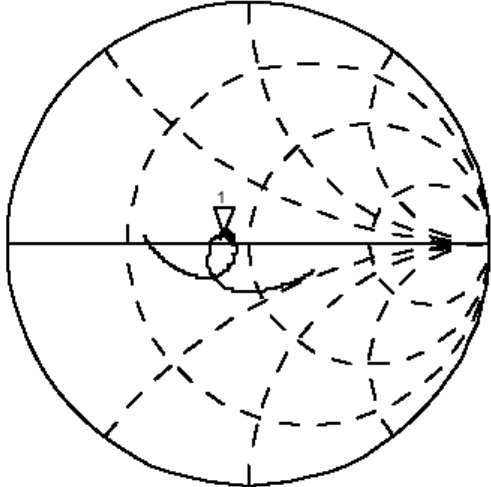

CH2 S22 1 UFS 1: 39.922 7.5566 4.6282 nH 259.861000 MHz

CH2 TARGET VALUE NOT FOUND

Cor

PRm

HLd

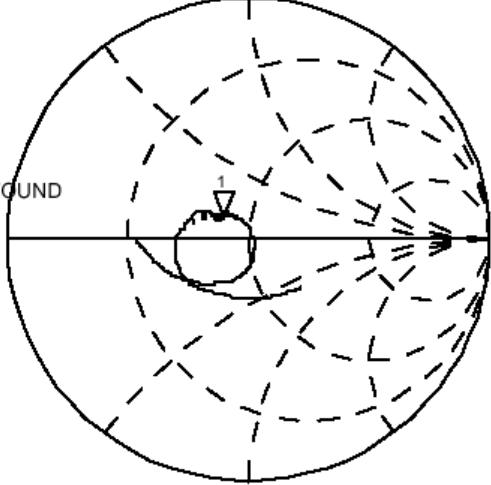

CH2 Markers

BW: 0.000000 MHz

cent: 0.000000 MHz

Q: 0.0000

1_loss: 39.922 MHz

START 244.861000 MHz

STOP 274.861000 MHz

SF2025B
50 Ohm System

Discontinued

Matching Circuits

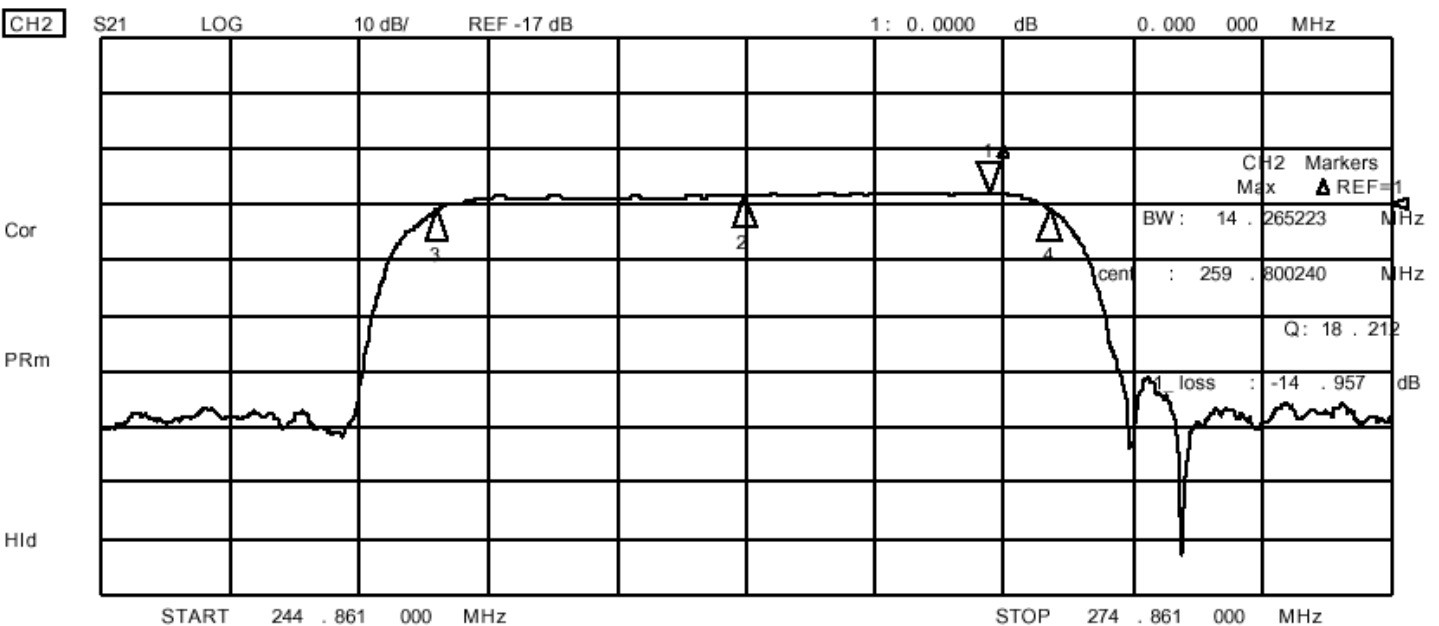
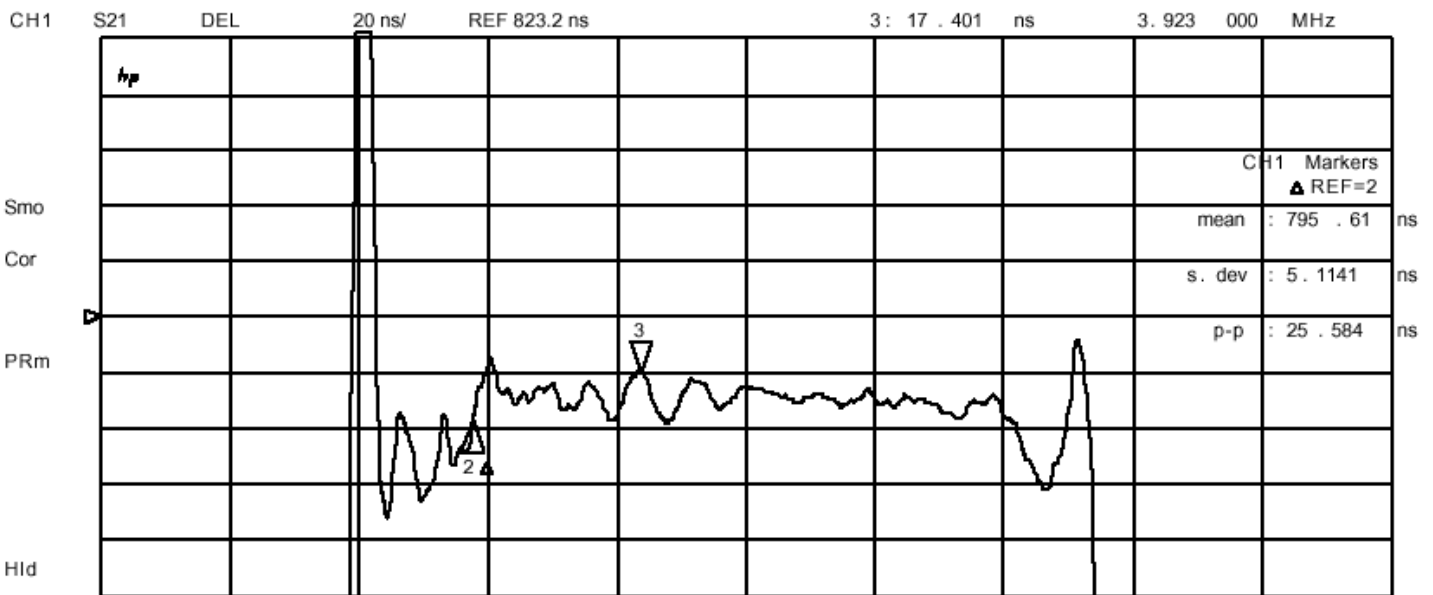
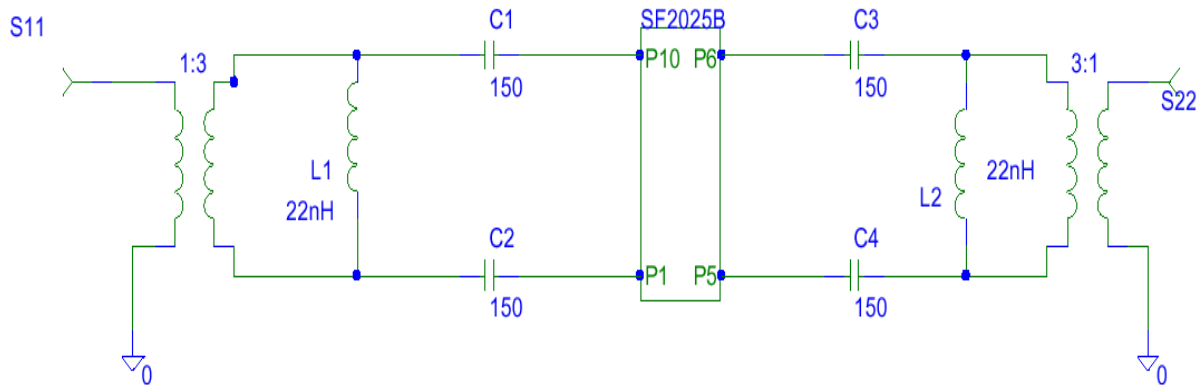

Discontinued

Matching Circuits

better rejection tuning

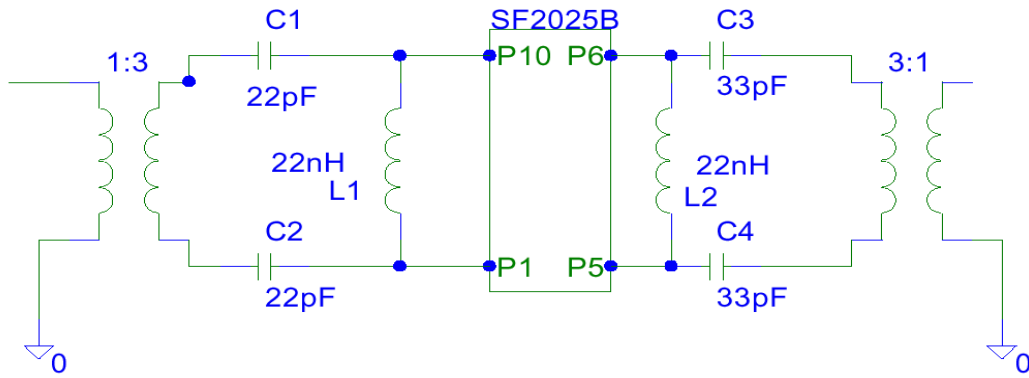

CH1 S11 1 UFS 1: 50 .018 11 .121 6.8112 nH 259 .861 000 MHz

∠p

Cor

PRm

Hid

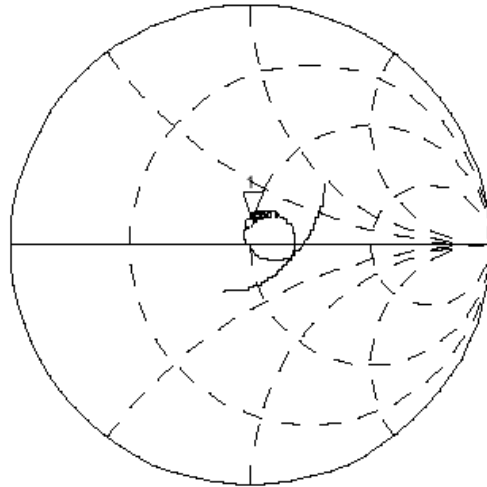

CH2 S22 1 UFS 1: 42 .555 11 .117 6.8089 nH 259 .861 000 MHz

Cor

PRm

Hid

CH2 TARGET VALUE NOT FOUND

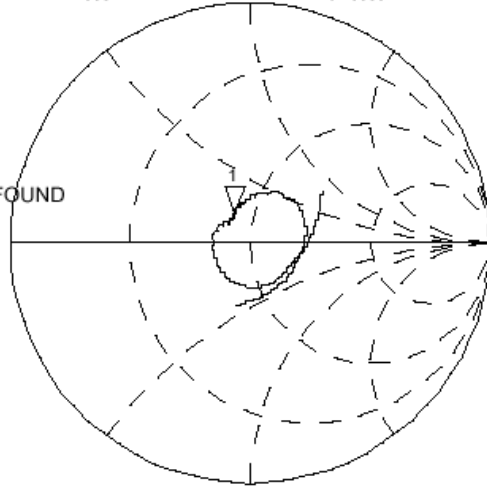

CH2 Markers

BW: 0.000000 MHz

cent : 0.000000 MHz

Q: 0.0000

1_loss : 42.555 Ω

START 244 .861 000 MHz

STOP 274 .861 000 MHz

SF2025B
50 Ohm System

Discontinued

22 Dec 2003 16:58:01

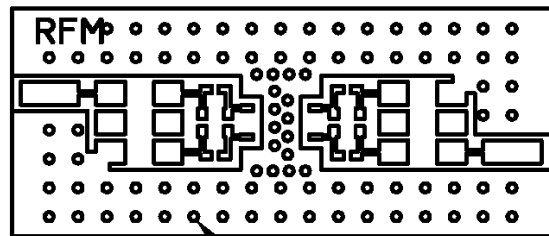
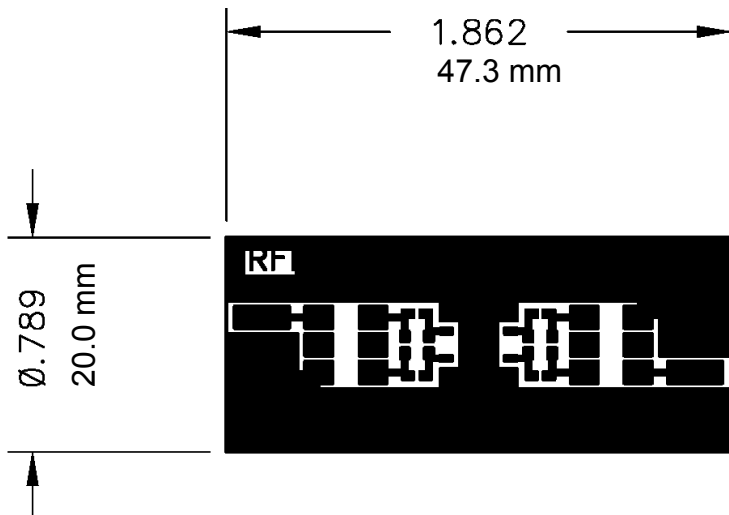
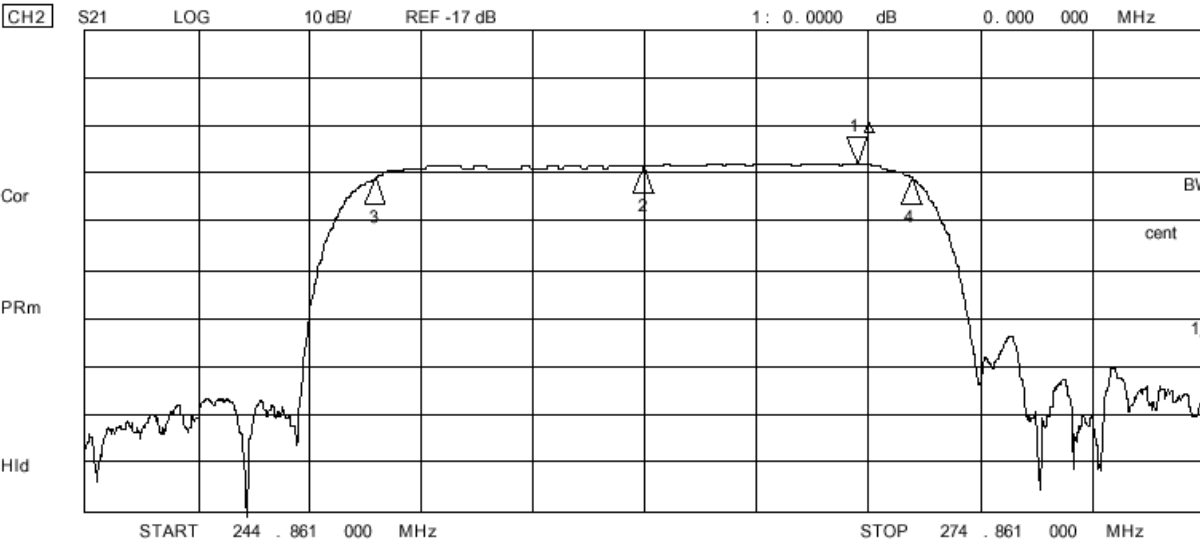
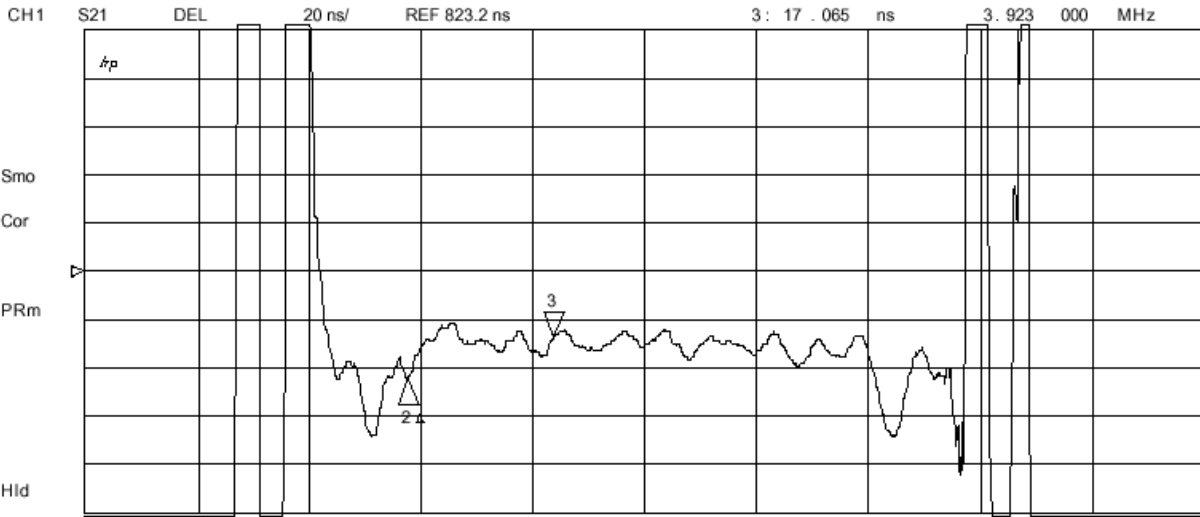

ALL HOLES PLATED THRU - \varnothing 1/32 DRILL

Discontinued

SMP-03 Case

10-Terminal Ceramic Surface-Mount Case

7 x 5 mm Nominal Footprint

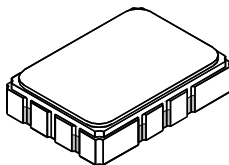

Recommended PCB Footprint

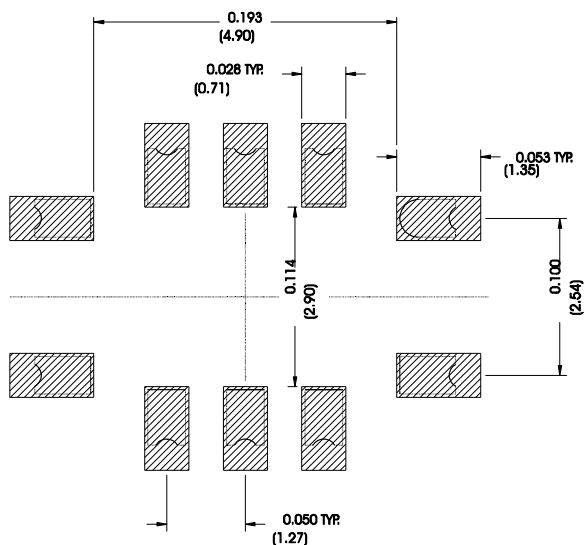

Case Dimensions						
Dimension	mm			Inches		
	Min	Nom	Max	Min	Nom	Max
A	6.80	7.00	7.20	0.268	0.276	0.283
B	4.80	5.00	5.20	0.189	0.197	0.205
C		1.65	2.00		0.065	0.079
D	.47	0.60	.73	0.019	0.024	0.029
E	2.41	2.54	2.67	0.095	0.100	0.105
H	0.87	1.0	1.13	0.034	0.039	0.044
J	4.87	5.00	5.13	0.192	0.197	0.202
K	2.87	3.00	3.13	0.113	0.118	0.123
P	1.14	1.27	1.40	0.045	0.050	0.055

Materials	
Solder Pad Termination	Au plating 30 - 60 μmches (76.2-152 μm) over 80-200 μmches (203-508 μm) Ni.
Lid	Fe-Ni-Co Alloy Electroless Nickel Plate (8-11% Phosphorus) 100-200 μmches Thick
Body	Al ₂ O ₃ Ceramic
Pb Free	

Electrical Connections		
Connection		Terminals
Port 1	Input or Return	10
	Return or Input	1
Port 2	Output or Return	5
	Return or Output	6
Ground		All others
Single Ended Operation		Return is ground
Differential Operation		Return is hot

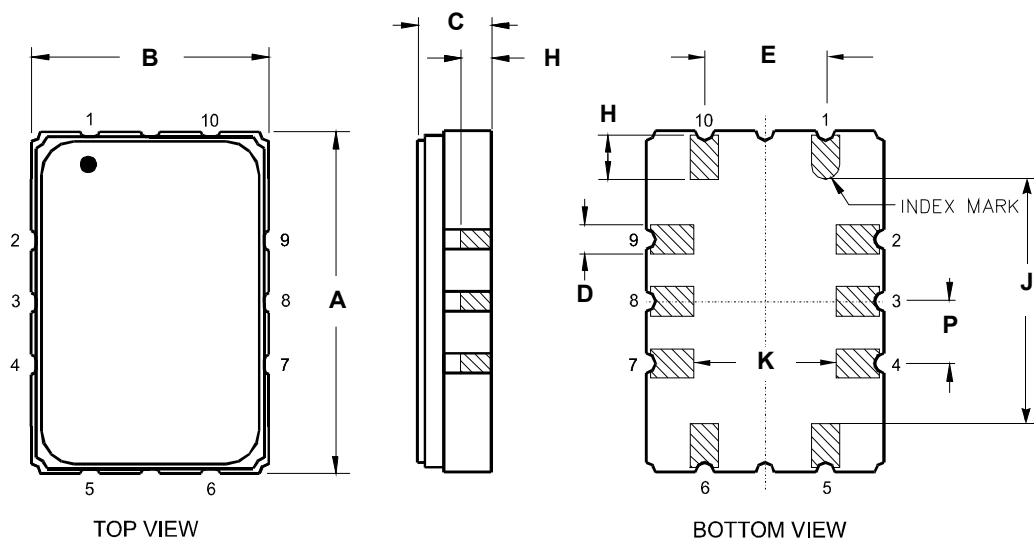

Tape and Reel Specifications

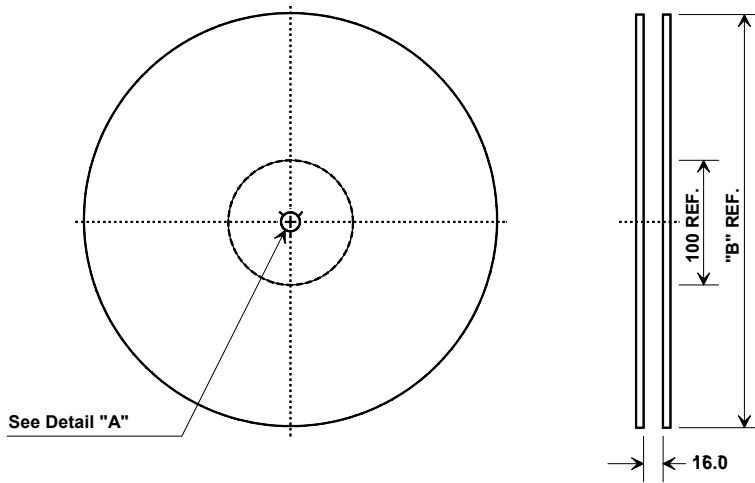

"B"		Quantity Per Reel
Inches	millimeters	
7	178	500
13	330	2000

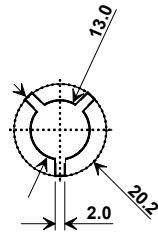

COMPONENT ORIENTATION and DIMENSIONS

Carrier Tape Dimensions	
Ao	5.5 mm
Bo	7.5 mm
Ko	2.0 mm
Pitch	8.0 mm
W	16.0 mm

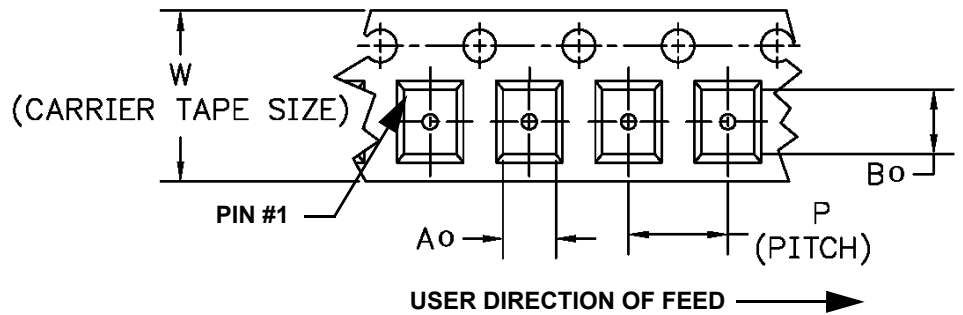
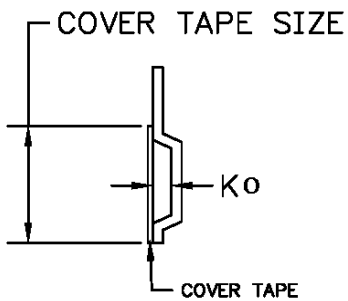

Mouser Electronics

Authorized Distributor

Click to View Pricing, Inventory, Delivery & Lifecycle Information:

[Murata:](#)

[SF2025B](#)

Данный компонент на территории Российской Федерации

Вы можете приобрести в компании MosChip.

Для оперативного оформления запроса Вам необходимо перейти по данной ссылке:

<http://moschip.ru/get-element>

Вы можете разместить у нас заказ для любого Вашего проекта, будь то серийное производство или разработка единичного прибора.

В нашем ассортименте представлены ведущие мировые производители активных и пассивных электронных компонентов.

Нашей специализацией является поставка электронной компонентной базы двойного назначения, продукции таких производителей как XILINX, Intel (ex.ALTERA), Vicor, Microchip, Texas Instruments, Analog Devices, Mini-Circuits, Amphenol, Glenair.

Сотрудничество с глобальными дистрибьюторами электронных компонентов, предоставляет возможность заказывать и получать с международных складов практически любой перечень компонентов в оптимальные для Вас сроки.

На всех этапах разработки и производства наши партнеры могут получить квалифицированную поддержку опытных инженеров.

Система менеджмента качества компании отвечает требованиям в соответствии с ГОСТ Р ИСО 9001, ГОСТ РВ 0015-002 и ЭС РД 009

Офис по работе с юридическими лицами:

105318, г.Москва, ул.Щербаковская д.3, офис 1107, 1118, ДЦ «Щербаковский»

Телефон: +7 495 668-12-70 (многоканальный)

Факс: +7 495 668-12-70 (доб.304)

E-mail: info@moschip.ru

Skype отдела продаж:

moschip.ru

moschip.ru_4

moschip.ru_6

moschip.ru_9