

HCPL-T250

1.5 Amp Output Current IGBT Gate Drive Optocoupler



Data Sheet



Description

The HCPL-T250 contains GaAs LED. The LED is optically coupled to an integrated circuit with a power output stage. This optocoupler is ideally suited for driving power IGBTs and MOSFETs used in motor control inverter applications. The high operating voltage range of the output stage provides the drive voltages required by gate controlled devices. The voltage and current supplied by this optocoupler makes it ideally suited for directly driving IGBTs with ratings up to 1200 V/25 A. For IGBTs with higher ratings, the HCPL-T250 can be used to drive a discrete power stage which drives the IGBT gate.

Functional Diagram

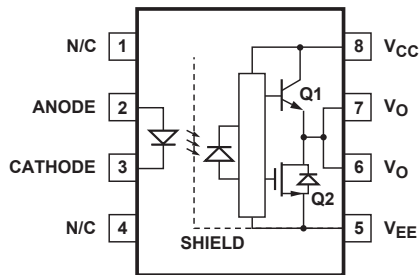

Truth Table

LED	V _{out}
ON	HIGH
OFF	LOW

A 0.1 μ F bypass capacitor must be connected between pins 5 and 8.

Features

- Input threshold current (I_{FLH}): 5 mA (max.)
- Supply current (I_{CC}): 11 mA (max.)
- Supply voltage (V_{CC}): 15-35V
- Output current (I_O): ± 0.5 A (min.)
- Switching time (t_{PLH}/t_{PHL}): 0.5 μ s (max.)
- Isolation voltage (V_{ISO}): 3750 Vrms (min.)
- UL 1577 recognized: File No. E55361
- CSA approved
- IEC/EN/DIN EN 60747-5-2 approved with $V_{IORM} = 630$ V_{peak}
- 5 kV/ μ s Minimum Common Mode Rejection (CMR) at $V_{cm} = 1500$ V
- Creepage distance: 7.4 mm
Clearance: 7.1 mm

Applications

- IGBT/MOSFET gate drive
- AC/brushless DC motor drives
- Industrial inverters
- Switch mode power supplies

CAUTION: It is advised that normal static precautions be taken in handling and assembly of this component to prevent damage and/or degradation which may be induced by ESD.

Ordering Information

HCPL-T250 is UL Recognized with 3750 Vrms for 1 minute per UL1577.

Part Number	Option		Package	Surface Mount	Gull Wing	Tape & Reel	IEC/EN/DIN EN 60747-5-2	Quantity
	RoHS Compliant	Non RoHS Compliant						
HCPL-T250	-000E	No option	300 mil DIP-8					50 per tube
	-300E	#300		X	X			50 per tube
	-500E	#500		X	X	X		1000 per reel
	-060E	#060					X	50 per tube
	-360E	#360		X	X		X	50 per tube
	-560E	#560		X	X	X	X	1000 per reel

To order, choose a part number from the part number column and combine with the desired option from the option column to form an order entry.

Example 1:

HCPL-T250-560E to order product of 300 mil DIP Gull Wing Surface Mount package in Tape and Reel packaging with IEC/EN/DIN EN 60747-5-2 Safety Approval in RoHS compliant.

Example 2:

HCPL-T250 to order product of 300 mil DIP package in tube packaging and non RoHS compliant.

Option datasheets are available. Contact your Avago sales representative or authorized distributor for information.

Remarks: The notation '#XXX' is used for existing products, while (new) products launched since 15th July 2001 and RoHS compliant option will use '-XXXE'.

Package Outline Drawings
Standard DIP Package

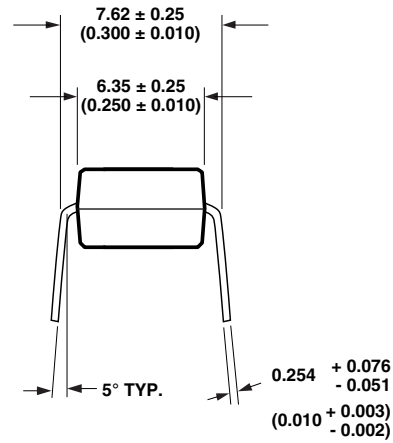
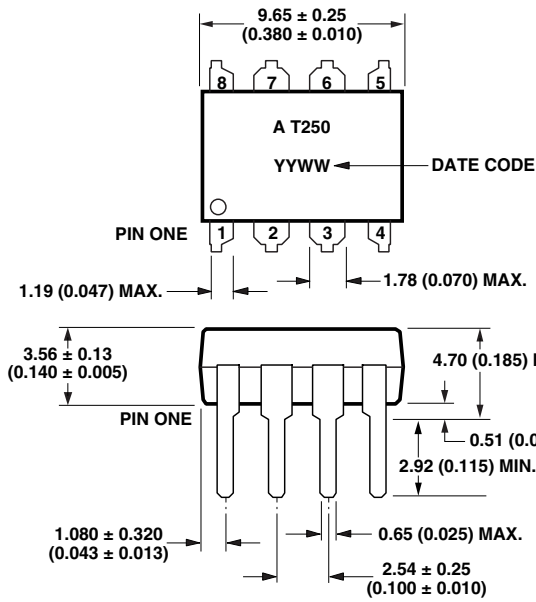

DIMENSIONS IN MILLIMETERS AND (INCHES).
 NOTE: FLOATING LEAD PROTRUSION IS 0.25 mm (10 mils) MAX.

Gull Wing Surface Mount Option 300

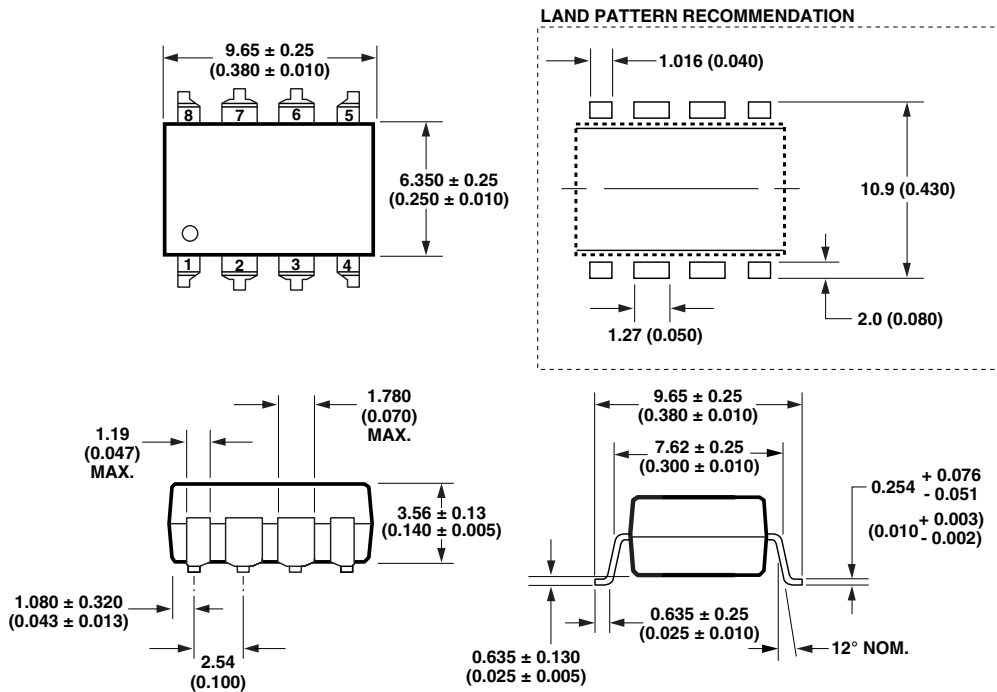

DIMENSIONS IN MILLIMETERS (INCHES).
 LEAD COPLANARITY = 0.10 mm (0.004 INCHES).
 NOTE: FLOATING LEAD PROTRUSION IS 0.25 mm (10 mils) MAX.

Solder Reflow Thermal Profile

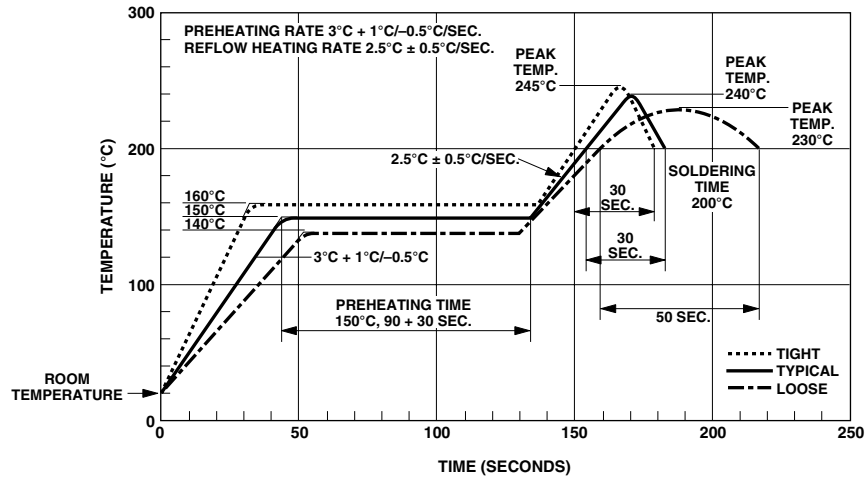

Note: Non-halide flux should be used.

Recommended Pb-Free IR Profile

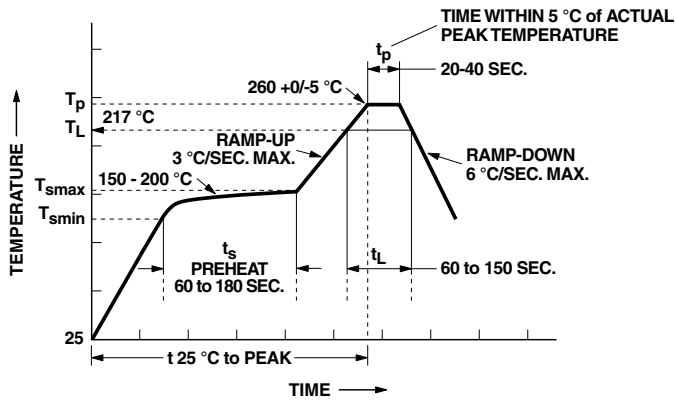

NOTES:
 THE TIME FROM 25 °C TO PEAK TEMPERATURE = 8 MINUTES MAX.
 $T_{smax} = 200^{\circ}\text{C}$, $T_{smin} = 150^{\circ}\text{C}$

Note: Non-halide flux should be used.

Regulatory Information

The HCPL-T250 has been approved by the following organizations:

UL

Recognized under UL 1577, Component Recognition Program, File E55361.

IEC/EN/DIN EN 60747-5-2

Approved under:
IEC 60747-5-2:1997 + A1:2002
EN 60747-5-2:2001 + A1:2002
DIN EN 60747-5-2 (VDE 0884 Teil 2):2003-01.
(Option 060 only)

CSA

Approved under CSA Component Acceptance Notice #5, File CA 88324.

Insulation and Safety Related

Parameter	Symbol	Value	Units	Conditions
Minimum External Air Gap (Clearance)	L(101)	7.1	mm	Measured from input terminals to output terminals, shortest distance through air.
Minimum External Tracking (Creepage)	L(102)	7.4	mm	Measured from input terminals to output terminals, shortest distance path along body.
Minimum Internal Plastic Gap (Internal Clearance)		0.08	mm	Insulation thickness between emitter and detector; also known as distance through insulation
Tracking Resistance (Comparative Tracking Index)	CTI	≥175	Volts	DIN IEC 112/VDE 0303 Part 1
Isolation Group		IIIa		Material Group (DIN VDE 0110, 1/89, Table 1)

Absolute Maximum Ratings (Compared with HCPL-3120)

Parameter	Symbol	Units	HCPL-3120		HCPL-T250		Note
			Min.	Max.	Min.	Max.	
Operating Temperature	T_A	°C	-40	100	-20	85	
"High" Peak Output Current	$I_{OH(PEAK)}$	A		2.5		1.5	1
"High" Peak Output Current	$I_{OL(PEAK)}$	A		2.5		1.5	
Storage Temperature	T_S	°C	-55	125	-55	125	
Average Input Current	$I_{F(AVG)}$	mA		25		20	2
Peak Transient Input Current (<1 μs Pulse Width, 300 pps)	$I_{F(TRAN)}$	A		1.0		1.0	
Reverse Input Voltage	V_R	V		5		5	
Supply Voltage	$(V_{CC} - V_{EE})$	V	0	35	0	35	
Output Voltage	V_O	V	0	V_{CC}	0	V_{CC}	
Output Power Dissipation	P_O	mW		250		250	3
Lead Solder Temperature			260°C for 10 sec., 1.6 mm below seating plane				
Solder Reflow Temperature Profile			See Package Outline Drawings section				

Notes:

1. Maximum pulse width = 10 μs, maximum duty cycle = 0.2%. See HCPL-3120 Applications section for additional details on limiting $I_{OH(PEAK)}$.
2. Derate linearly above 70°C free-air temperature at a rate of 0.3 mA/°C.
3. Derate linearly above 70°C free-air temperature at a rate of 4.8 mW/°C.

Recommended Operating Conditions

Parameter	Symbol	Min.	Max.	Units
Power Supply Voltage	$V_{CC} - V_{EE}$	15	30	V
Input Current (ON)	$I_{F(ON)}$	7	16	mA
Input Voltage (OFF)	$V_{F(OFF)}$	-3.6	0.8	V

DC Electrical Specifications (Compared with HCPL-3120)

Over recommended operating conditions ($I_{F(ON)} = 7$ to 16 mA, $V_{F(OFF)} = -3.6$ to 0.8 V, $V_{CC} = 15$ to 30 V, $V_{EE} = \text{Ground}$) unless otherwise specified.

Parameter	Symbol	Units	HCPL-3120			HCPL-T250			Test Conditions	Note
			Min.	Typ.*	Max.	Min.	Typ.*	Max.		
Input Forward Voltage	V_F	V	1.2	1.5	1.8		1.6	1.8	$I_F = 10$ mA	
Temperature Coefficient of Forward Voltage	$\Delta V_F / \Delta T_A$	mV/°C		-1.6			-2.0		$I_F = 10$ mA	
Input Reverse Current	I_R	μA			10			10	$V_R = 5$ V	
Input Capacitance	C_{IN}	pF		60			60	250	$V_F = 0$ V, $F = 1$ MHz	
High Level Output Current	I_{OH}	A	0.5	1.5		0.5	1.5		$V_O = V_{CC} - 4$ V $V_O = V_{CC} - 15$ V	
Low Level Output Current	I_{OL}	A	0.5	2.0		0.5	2.0		$V_O = V_{CC} - 4$ V $V_O = V_{CC} - 15$ V	
High Level Output Voltage	V_{OH}	V	$V_{CC} - 4$	$V_{CC} - 3$		$V_{CC} - 4$	$V_{CC} - 3$		$I_O = -100$ mA	
Low Level Output Voltage	V_{OL}	V		$V_{EE} + 0.1$	$V_{EE} + 0.5$		$V_{EE} + 0.8$	$V_{EE} + 2.5$	$I_O = 100$ mA	
High Level Supply Current	I_{CCH}	mA		2.0	5		7	11	Output Open $I_F = 7$ to 16 mA	
Low Level Supply Current	I_{CCL}	mA		2.0	5		7.5	11	Output Open $V_F = -3.0$ to $+0.8$ V	
Threshold Input Current Low to High	I_{FLH}	mA		2.3	5		1.2	5	$I_O = 0$ mA, $V_O > 5$ V	
Threshold Input Voltage High to Low	V_{FHL}	V	0.8			0.8				
Supply Voltage	V_{CC}	V	15		30	15		30		
Capacitance (Input-Output)	C_{I-O}	pF		0.6			1.0			
Resistance (Input-Output)	R_{I-O}	Ω		10^{12}			10^{12}			

*All typical values at $T_A = 25^\circ\text{C}$ and $V_{CC} - V_{EE} = 3^\circ\text{V}$, unless otherwise noted.

Switching Specifications (AC) (Compared with HCPL-3120)

Over recommended operating conditions ($T_A = -40$ to 100°C , $I_{F(ON)} = 7$ to 16 mA, $V_{F(OFF)} = -3.6$ to 0.8 V, $V_{CC} = 15$ to 30 V, $V_{EE} = \text{Ground}$) unless otherwise specified.

Parameter	Symbol	Units	HCPL-3120 ($-40^\circ\text{C} \sim 100^\circ\text{C}$)			HCPL-T250 ($-20^\circ\text{C} \sim 85^\circ\text{C}$)			Test Conditions	Note
			Min.	Typ.*	Max.	Min.	Typ.*	Max.		
Propagation Delay Time to High Output Level	t_{PHL}	μs	0.1	0.27	0.5		0.27	0.5	Rg = 10 Ω Cg = 10 nF, f = 10 kHz, Duty Cycle = 50%	
Propagation Delay Time to Low Output Level	T_{PLH}	μs	0.1	0.3	0.5		0.3	0.5		
Output Rise Time	t_R	μs		0.1		N.A.				
Output Fall Time	t_F	μs		0.1		N.A.				
Pulse Width Distortion	PWD	μs			0.3			N.A.		
Propagation Delay Difference Between Any Two Parts	($t_{PHL} -$ t_{PLH}) PDD	μs	-0.35		0.35	N.A.		N.A.	4	
Output High Level Common Mode Transient Immunity	$ CM_H $	kV/ μs	25	35		5		$T_A = 25^\circ\text{C}$ $V_{CC} = 30$ V HCPL $I_F = 10$ mA -3120 $V_{CM} = 1500$ V HCPL $I_F = 10$ mA -T250 $V_{CM} = 600$ V	5	
Output Low Level Common Mode Transient Immunity	$ CM_L $	kV/ μs	25	35		5		$T_A = 25^\circ\text{C}$ $V_F = 0$ V HCPL $V_{CM} = 1500$ V HCPL $V_{CM} = 600$ V	5	

*All typical values at $T_A = 25^\circ\text{C}$ and $V_{CC} - V_{EE} = 30$ V, unless otherwise noted.

Notes:

- The difference between t_{PHL} and t_{PLH} between any two HCPL-3120 parts under the same test condition.
- Common mode transient immunity in the high state is the maximum tolerable dV_{CM}/dt of the common mode pulse, V_{CM} , to assure that the output will remain in the high state (i.e., $V_O > 15.0$ V).
- Common mode transient immunity in a low state is the maximum tolerable dV_{CM}/dt of the common mode pulse, V_{CM} , to assure that the output will remain in a low state (i.e., $V_O < 1.0$ V).

For product information and a complete list of distributors, please go to our website: www.avagotech.com

Avago, Avago Technologies, and the A logo are trademarks of Avago Technologies Limited in the United States and other countries. Data subject to change. Copyright © 2007 Avago Technologies Limited. All rights reserved. Obsoletes 5989-2144EN AV02-0166EN - October 16, 2007

Avago
TECHNOLOGIES

Данный компонент на территории Российской Федерации

Вы можете приобрести в компании MosChip.

Для оперативного оформления запроса Вам необходимо перейти по данной ссылке:

<http://moschip.ru/get-element>

Вы можете разместить у нас заказ для любого Вашего проекта, будь то серийное производство или разработка единичного прибора.

В нашем ассортименте представлены ведущие мировые производители активных и пассивных электронных компонентов.

Нашей специализацией является поставка электронной компонентной базы двойного назначения, продукции таких производителей как XILINX, Intel (ex.ALTERA), Vicor, Microchip, Texas Instruments, Analog Devices, Mini-Circuits, Amphenol, Glenair.

Сотрудничество с глобальными дистрибьюторами электронных компонентов, предоставляет возможность заказывать и получать с международных складов практически любой перечень компонентов в оптимальные для Вас сроки.

На всех этапах разработки и производства наши партнеры могут получить квалифицированную поддержку опытных инженеров.

Система менеджмента качества компании отвечает требованиям в соответствии с ГОСТ Р ИСО 9001, ГОСТ РВ 0015-002 и ЭС РД 009

Офис по работе с юридическими лицами:

105318, г.Москва, ул.Щербаковская д.3, офис 1107, 1118, ДЦ «Щербаковский»

Телефон: +7 495 668-12-70 (многоканальный)

Факс: +7 495 668-12-70 (доб.304)

E-mail: info@moschip.ru

Skype отдела продаж:

moschip.ru

moschip.ru_4

moschip.ru_6

moschip.ru_9