

San Ace C175

Centrifugal Fan

Centrifugal Fan 175mm

■ Features

Large air flow and high static pressure

- Maximum air flow : 14.0 m³/min
- Maximum static pressure : 885 Pa

Energy-saving design

- Power consumption: 93.6 W

Low noise

- Sound Pressure Level: 73dB(A)



φ175mm×69mm

■ Specifications Note 3)

Model No.	Rated Voltage [V]	Operating Voltage Range [V]	PWM Duty Cycle [%] <small>Note 1,2)</small>	Rated Current [A]	Rated Input [W]	Rated Speed [min ⁻¹]	Air Flow		Static Pressure		SPL [dB(A)]	Operating Temperature [°C]	Life Expectancy [h]
							[m ³ /min]	[CFM]	[Pa]	[inchH ₂ O]			
9TG24P0G01	24	20.4 to 27.6	100	3.9	93.6	4,700	14.0	494.7	885	3.55	73	-10 to +60	40,000
9TG48P0G01	48	36 to 55.2	100	1.95	93.6	4,700	14.0	494.7	885	3.55	73	-10 to +70	

Note 1 : PWM Frequency : 25kHz

Note 2 : Fan does not rotate when PWB duty cycle is 0%.

Note 3 : When inlet nozzle [Option (Model : 109-1073)] is mounted.

Note 4 : Max input is 130 W at rated voltage.

■ Common Specifications

- Material Motor case: Aluminum, Impeller: Plastics (Flammability: UL94V-1Min.)
- Life Expectancy Varies for each model
(L10: Survival rate: 90% at 60°C, rated voltage, and continuously run in a free air state)
- Motor Protection System Current blocking function and reverse polarity protection
- Dielectric Strength 50/60 Hz, 500VAC, 1 minute (between lead conductor and motor case)
- Sound Pressure Level (SPL) Expressed as the value at 1m from air inlet side
- Operating Temperature Varies for each model (Non-condensing)
- Storage Temperature -30°C to +70°C (Non-Condensing)
- Lead Wire ⊕red ⊖black Sensor: yellow Control: brown
- Mass Approx. 750g

175mm

SanAce C175

Air Flow - Static Pressure Characteristics

- PWM Duty Cycle

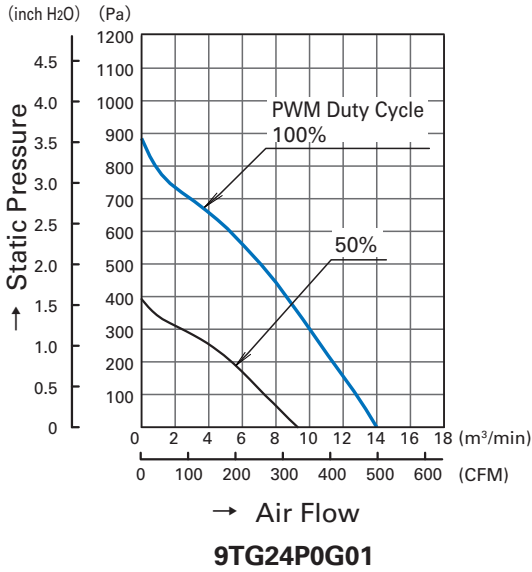

- Operating Voltage Range

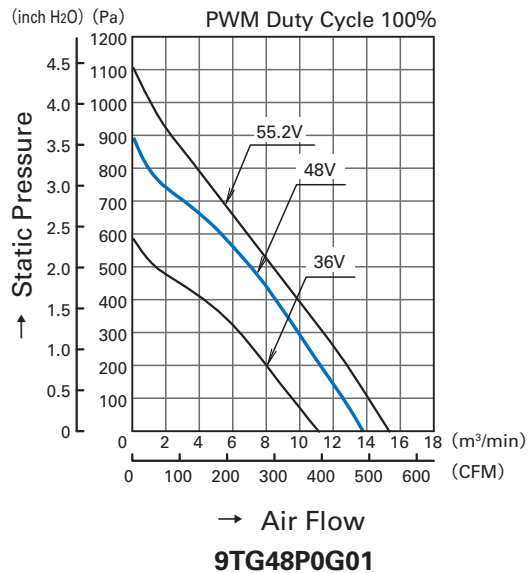
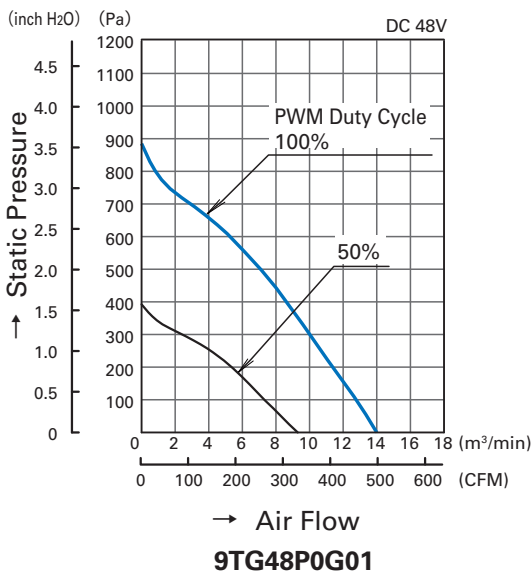
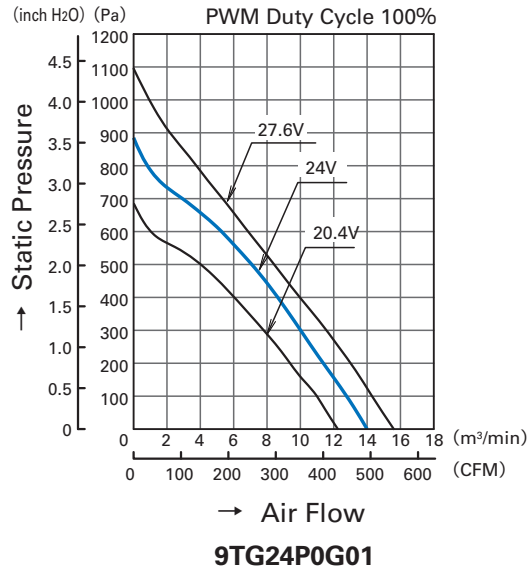

PWM Duty - Speed Characteristics Example

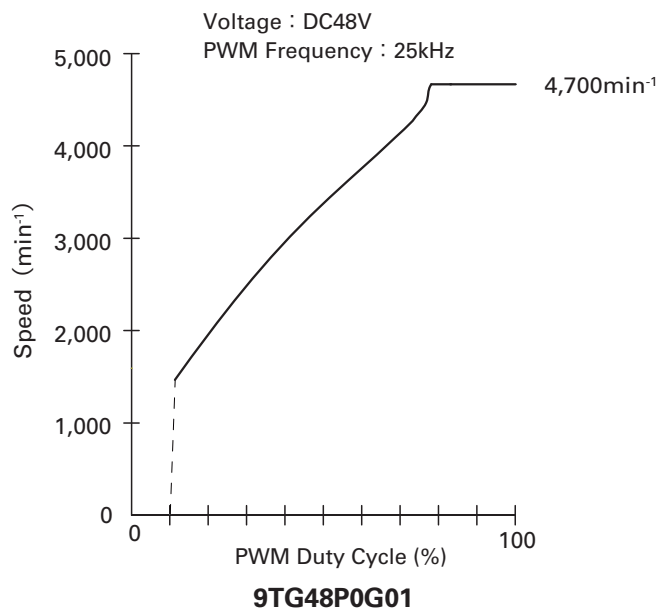
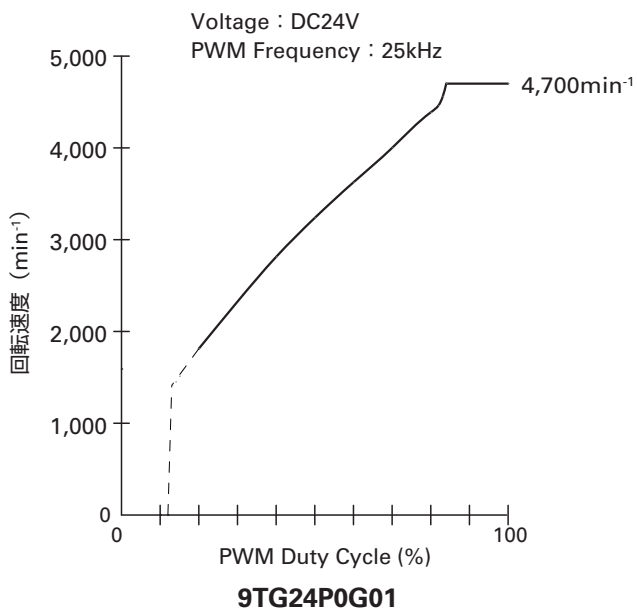

PWM Input Signal Example

Input Signal Wave Form

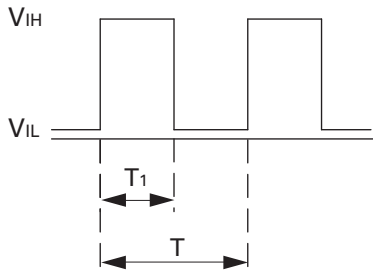

$V_{IH}=4.75V$ to $5.25V$

$V_{IL}=0V$ to $0.4V$

PWM Duty Cycle (%) = $\frac{T_1}{T} \times 100$

PWM Frequency 25 (kHz) = $\frac{1}{T}$

Source Current : 2mA Max. at control voltage 0V

Sink Current : 1mA Max. at control voltage 5.25V

Control Terminal Voltage : 5.25V Max. (Open Circuit)

When the control lead wire is no connecting, the speed is the same speed as at 100% of PWM cycle.

This fan speed should be controlled by PWM input signal of either TTL input or open collector, drain input.

Connection Schematic

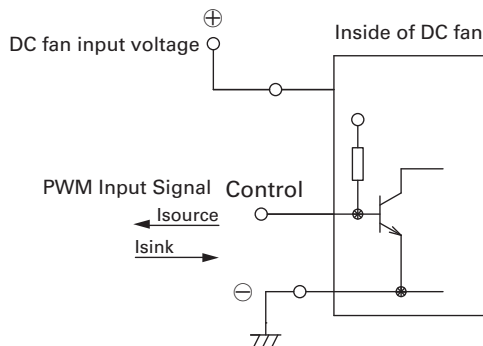

Specifications for Pulse Sensors

Output circuit : Open collector

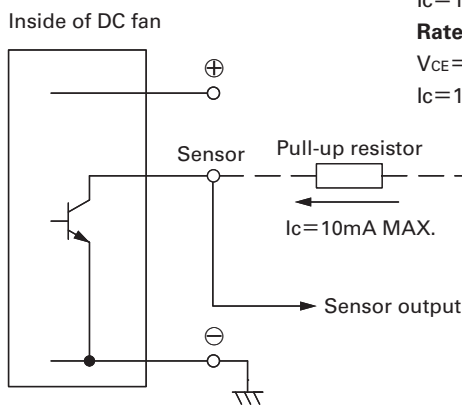

Rated Voltage 24V fan

$V_{CE}=+30V$ MAX.

$I_C=10mA$ MAX. [$V_{OL}=V_{CE} (SAT) =0.6V$ MAX.]

Rated Voltage 48V fan

$V_{CE}=+60V$ MAX.

$I_C=10mA$ MAX. [$V_{OL}=V_{CE} (SAT) =0.4V$ MAX.]

Output waveform (Need pull-up resistor)

In case of steady running

(One revolution)

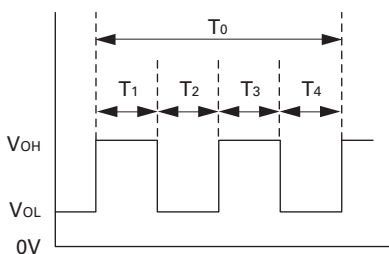

$T_{1\sim4} \doteq (1/4) T_0$

$T_{1\sim4} \doteq (1/4) T_0 = 60/4N$ (sec)

$N = \text{Fan speed (min}^{-1}\text{)}$

Dimensions (unit : mm)

Fan

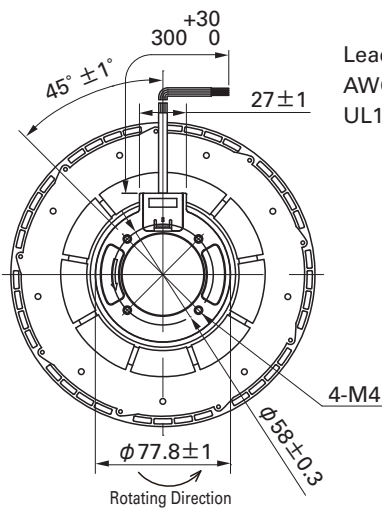
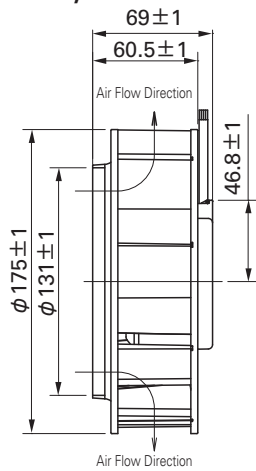

Lead Wire
AWG24
UL1430

Inlet nozzle
(Model : 109-1073)

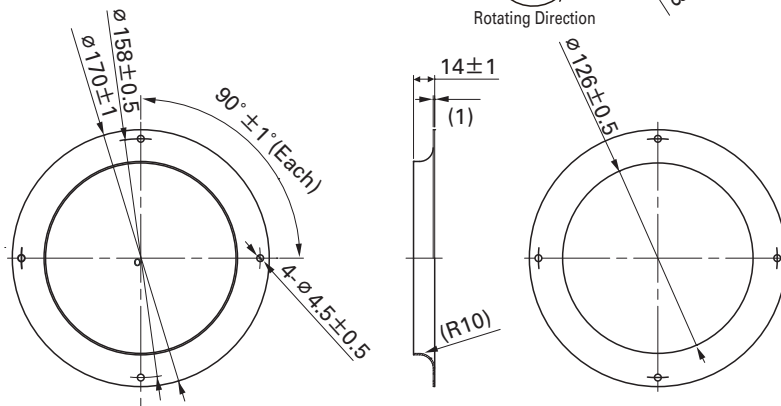

Inlet nozzle: Nozzle mounted in fan inlet side to adjust the flow of introduced air

Reference dimension of mounting holes and vent opening (unit : mm)

Fan side

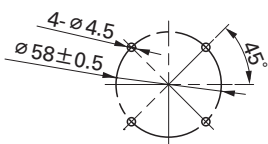

Inlet nozzle side

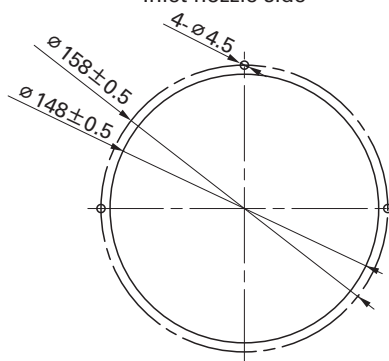

Reference diagram for mounting

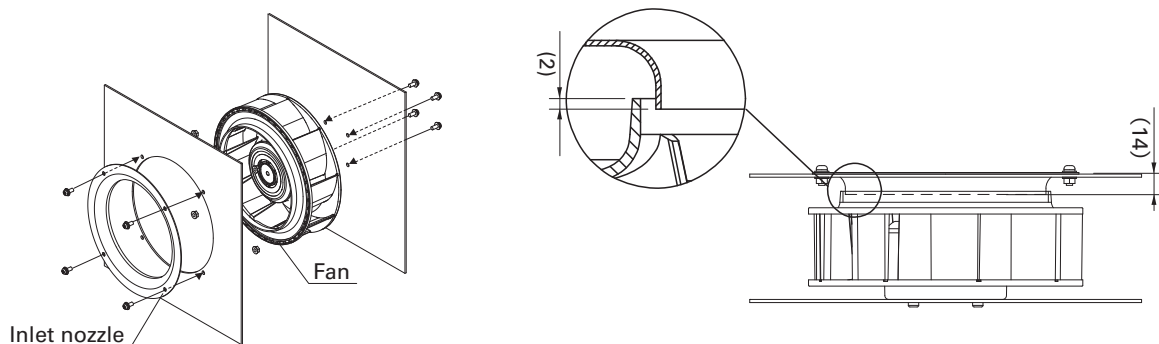

Screw length should be 4 mm or more but not exceeding 6 mm from fan edge face.
To prevent screw from loosening, use plain washer and spring washer.

Notice

- The products shown in the catalog are subject to Japanese Export Control Law. Diversion contrary to the law of exporting country is prohibited.
- To protect against electrolytic corrosion that may occur in locations with strong electromagnetic noise, we provide fans that are unaffected by electrolytic corrosion.

Mouser Electronics

Authorized Distributor

Click to View Pricing, Inventory, Delivery & Lifecycle Information:

Sanyo Denki:

[9TG24P0G01](#) [9TG48P0G01](#)

Данный компонент на территории Российской Федерации

Вы можете приобрести в компании MosChip.

Для оперативного оформления запроса Вам необходимо перейти по данной ссылке:

<http://moschip.ru/get-element>

Вы можете разместить у нас заказ для любого Вашего проекта, будь то серийное производство или разработка единичного прибора.

В нашем ассортименте представлены ведущие мировые производители активных и пассивных электронных компонентов.

Нашей специализацией является поставка электронной компонентной базы двойного назначения, продукции таких производителей как XILINX, Intel (ex.ALTERA), Vicor, Microchip, Texas Instruments, Analog Devices, Mini-Circuits, Amphenol, Glenair.

Сотрудничество с глобальными дистрибьюторами электронных компонентов, предоставляет возможность заказывать и получать с международных складов практически любой перечень компонентов в оптимальные для Вас сроки.

На всех этапах разработки и производства наши партнеры могут получить квалифицированную поддержку опытных инженеров.

Система менеджмента качества компании отвечает требованиям в соответствии с ГОСТ Р ИСО 9001, ГОСТ РВ 0015-002 и ЭС РД 009

Офис по работе с юридическими лицами:

105318, г.Москва, ул.Щербаковская д.3, офис 1107, 1118, ДЦ «Щербаковский»

Телефон: +7 495 668-12-70 (многоканальный)

Факс: +7 495 668-12-70 (доб.304)

E-mail: info@moschip.ru

Skype отдела продаж:

moschip.ru

moschip.ru_4

moschip.ru_6

moschip.ru_9