

## Tripolar overvoltage protection for network interfaces

### Features

- Triple crowbar protection
- Low capacitance
- Low holding current:  $I_H = 30$  mA minimum
- Surge current:  
 $I_{PP} = 200$  A, 2/10  $\mu$ s  
 $I_{PP} = 30$  A, 10/1000  $\mu$ s

### Benefits

- Trisil™ technology is not subject to ageing and provides a fail safe mode in short circuit for a better protection.
- This device can be used to help equipment to meet main standards such as UL1950, IEC 950 / CSA C22.2 and UL1459.
- Trisils have UL94 V0 approved resin.
- SO8 package is JEDEC registered.
- Trisils comply with the following standards GR-1089 Core, ITU-T-K20/K21, VDE0433, VDE0878, IEC 61000-4-2.

### Applications

Dedicated to data line protection, this device provides a tripolar protection function. It ensures the same protection capability with the same breakdown voltage in both common and differential modes.

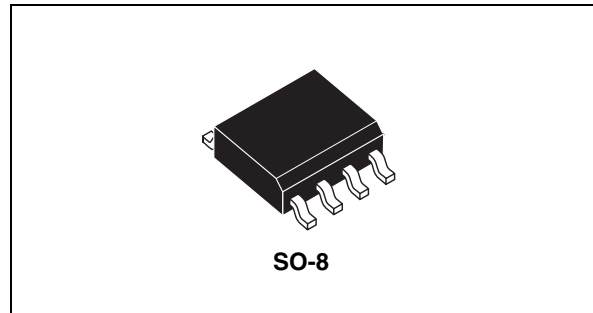

**Figure 1. Schematic diagram**

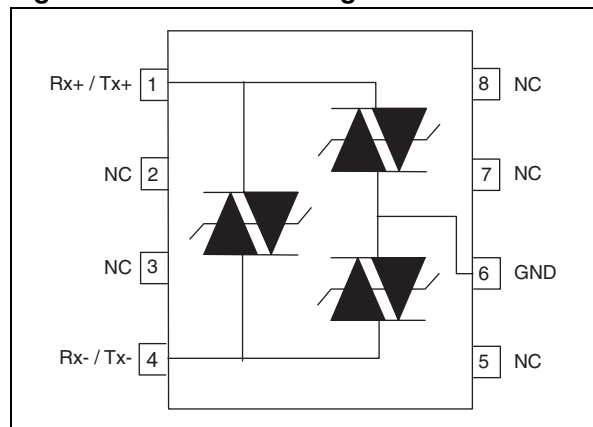

### Description

The TPN is a low capacitance transient surge arrester designed for protection of high debit rate communication networks. Its low capacitance avoids distortion of the signal as it has been designed for T1/E1 and Ethernet networks.

**TM:** Trisil is a trademark of STMicroelectronics

# 1 Characteristics

**Table 1. Compliant with the following standards**

	Peak surge voltage (V)	Voltage waveform (µs)	Required peak current (A)	Current waveform (µs)	Minimum serial resistor to meet standard (Ω)
<b>GR-1089-CORE First level</b>	2500	2/10	500	2/10	7.5
	1000	10/1000	100	10/1000	25
<b>GR-1089-CORE Intrabuilding</b>	1500	2/10	100	2/10	0
<b>ITU-T-K20/K21</b>	1000	10/700	25	5/310	0
<b>ITU-T-K20 (IEC 61000-4-2)</b>	6000	1/60 ns	ESD contact discharge		-
	8000		ESD air discharge		-
<b>VDE0433</b>	4000	10/700	100	5/310	40
	2000		50		0
<b>VDE0878</b>	4000	1.2/50	100	1/20	0
	2000		50		0
<b>IEC 61000-4-5</b>	2000	10/700	50	5/310	0
	2000	1.2/50	50	8/20	0

**Table 2. Absolute ratings (T<sub>amb</sub> = 25 °C)**

Symbol	Parameter	Value	Unit	
I <sub>PP</sub>	Peak pulse current: t <sub>r</sub> / t <sub>p</sub>	10/1000	30	A
		8/20	100	
		10/560	40	
		5/310	50	
		10/160	75	
		1/20	100	
		2/10	200	
I <sub>TSM</sub>	Non repetitive surge peak on-state current One cycle	50 Hz 60 Hz	8 9	A
	Non repetitive surge peak on-state current (F = 50Hz)	0.2 s 2 s	3 1.5	A
T <sub>stg</sub>	Storage temperature range	-55 to +150	°C	
T <sub>j</sub>	Operating junction temperature range	-40 to +150	°C	
T <sub>L</sub>	Maximum lead temperature for soldering during 10s	260	°C	

**Table 3. Thermal resistances**

Symbol	Parameter	Value	Unit
R <sub>th(j-a)</sub>	Junction to ambient	170	°C/W

**Table 4. Electrical characteristics - definitions ( $T_{amb} = 25^{\circ} C$ )**

Symbol	Parameter
$V_{RM}$	Stand-off voltage
$I_{RM}$	Leakage current at stand-off voltage
$V_R$	Continuous Reverse voltage
$V_{BR}$	Breakdown voltage
$V_{BO}$	Breakover voltage
$I_H$	Holding current
$I_{BO}$	Breakover current
$I_R$	Continuous reverse voltage
$I_{PP}$	Peak pulse current
C	Capacitance

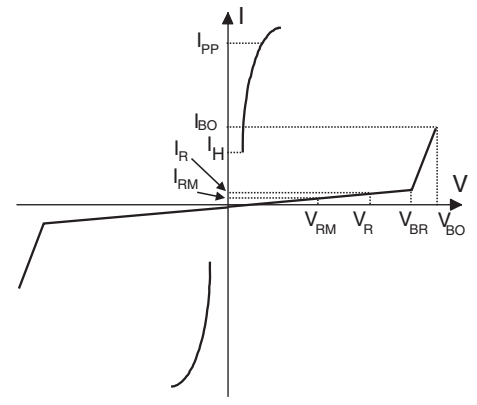
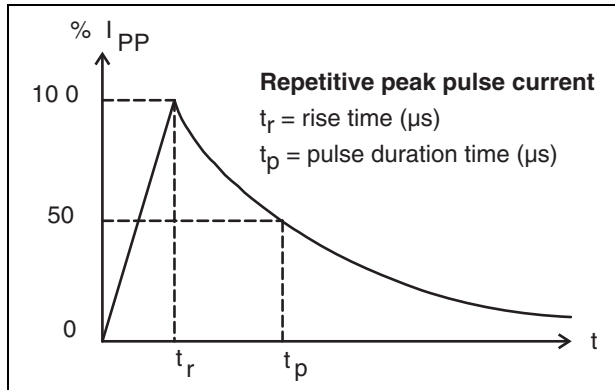

**Table 5. Static parameters**

Order code	$I_{RM}$ max. @ $V_{RM}$		$V_{BO}^{(1)}$ max. @ $I_{BO}$		$I_H^{(2)}$ min.	$C^{(3)}$ typ.
	$\mu A$	V	V	mA	mA	pF
TPN3021	4	28	38	300	30	16

1. See [Figure 6: Test circuit 1 for IBO and VBO parameters](#).
2. See [Figure 7: Test circuit 2 for dynamic IH parameter](#)
3.  $V_R = 0 V$  bias,  $V_{RMS} = 1 V$ ,  $F = 1 MHz$

**Figure 2. Pulse waveform**



**Figure 3. Non repetitive surge peak on-state current versus overload duration ( $T_j$  initial =  $25^{\circ} C$ )**

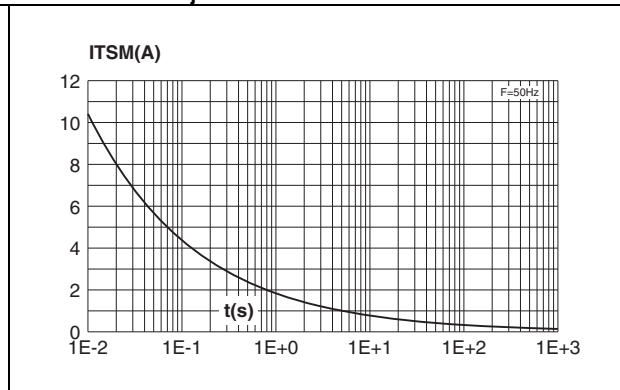

Figure 4. Variation of junction capacitance versus reverse voltage applied (typical values)

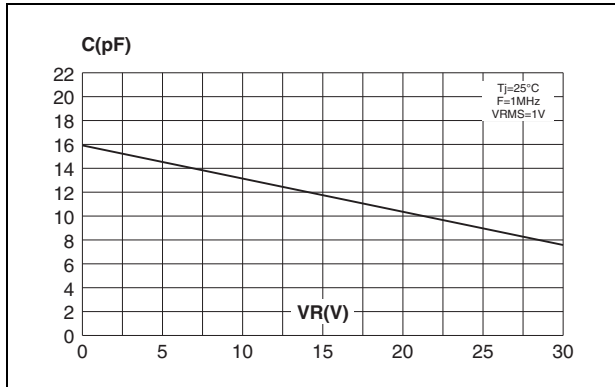
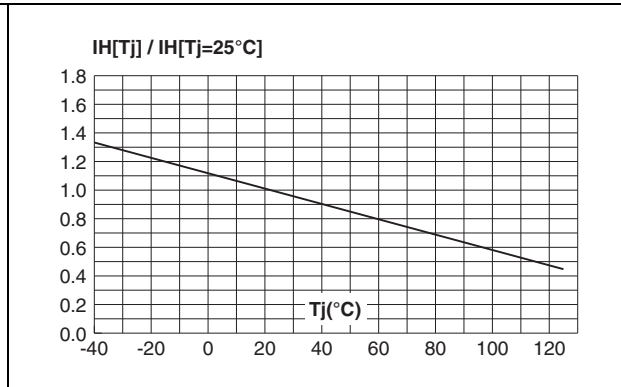

Figure 5. Relative variation of holding current versus junction temperature



## 2 Test circuits

### 2.1 Test procedure for test circuit 1

Figure 6. Test circuit 1 for  $I_{BO}$  and  $V_{BO}$  parameters

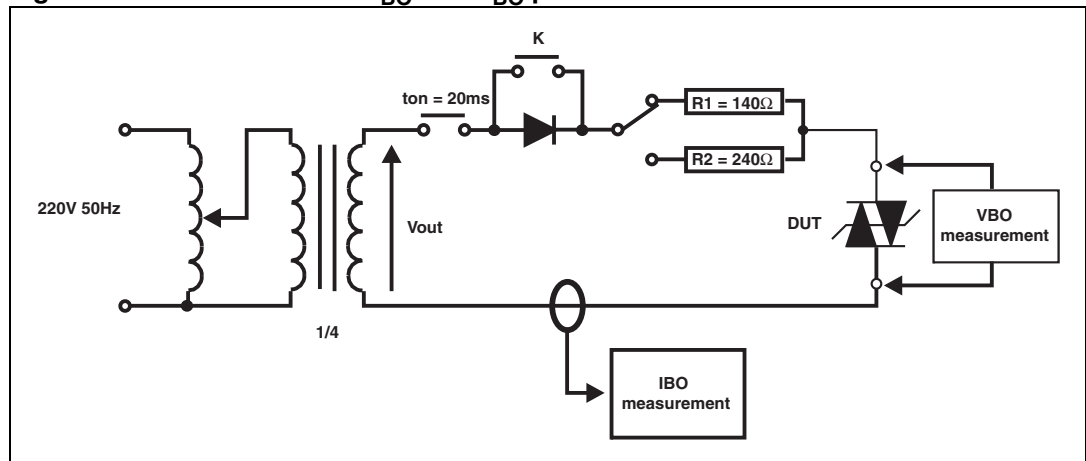

Pulse test duration ( $t_p = 20 \text{ ms}$ ):

- For bidirectional devices = switch K is closed
- For unidirectional devices = switch K is open

$V_{OUT}$  selection:

Device with  $V_{BO} < 200 \text{ V}$ ,  $V_{OUT} = 250 \text{ V}_{RMS}$ ,  $R1 = 140 \text{ } \Omega$

Device with  $V_{BO} \geq 200 \text{ V}$ ,  $V_{OUT} = 480 \text{ V}_{RMS}$ ,  $R2 = 240 \text{ } \Omega$

## 2.2 Test procedure for test circuit 2

Figure 7. Test circuit 2 for dynamic  $I_H$  parameter

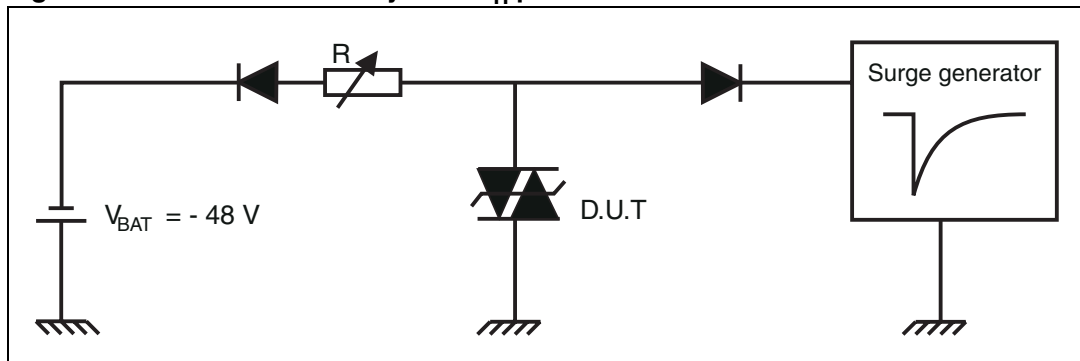

This is a go no-go test, which can confirm the holding current ( $I_H$ ) level.

### Procedure

1. Adjust the current level at the  $I_H$  value by short circuiting the AK of the D.U.T.
2. Fire the D.U.T. with a surge current  $I_{PP} = 10\text{A}$ ,  $10/1000\mu\text{s}$ .
3. The D.U.T. will come back off-state within 50 ms maximum.

### 3 Ordering information scheme

Figure 8. Ordering information scheme

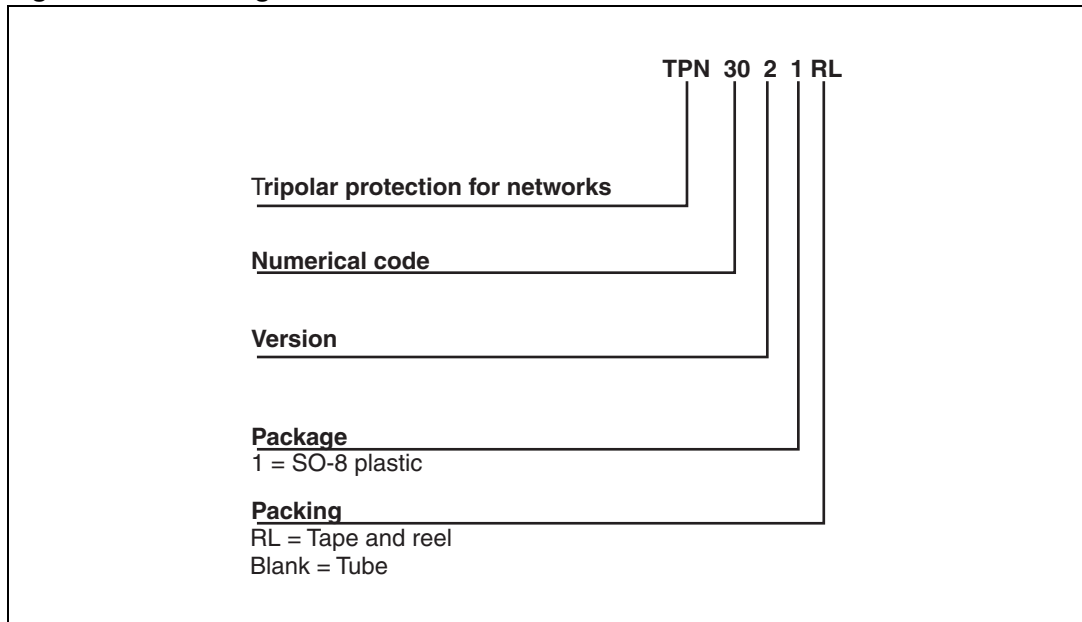

## 4 Package information

- Epoxy meets UL94, V0
- Lead-free package

In order to meet environmental requirements, ST offers these devices in different grades of ECOPACK® packages, depending on their level of environmental compliance. ECOPACK® specifications, grade definitions and product status are available at: [www.st.com](http://www.st.com). ECOPACK® is an ST trademark.

**Table 6. SO-8 dimensions**

Ref.	Dimensions					
	Millimeters			Inches		
	Min.	Typ.	Max.	Min.	Typ.	Max.
A			1.75			0.069
A1	0.1		0.25	0.004		0.010
A2	1.25			0.049		
b	0.28		0.48	0.011		0.019
C	0.17		0.23	0.007		0.009
D	4.80	4.90	5.00	0.189	0.193	0.197
E	5.80	6.00	6.20	0.228	0.236	0.244
E1	3.80	3.90	4.00	0.150	0.154	0.157
e		1.27			0.050	
h	0.25		0.50	0.010		0.020
L	0.40		1.27	0.016		0.050
L1		1.04			0.041	
k	0°		8°	0°		8°
ppp			0.10			0.004

**Footprint, dimensions in mm (inches)**

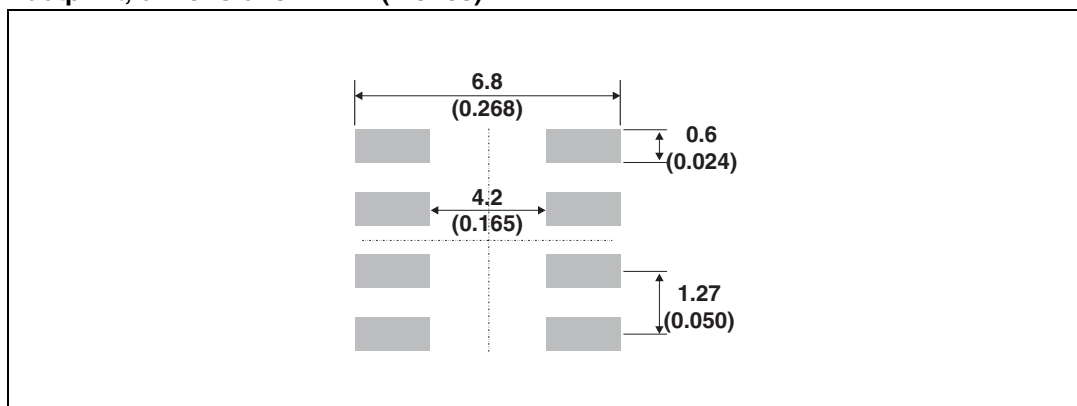

## 5 Ordering information

**Table 7. Ordering information**

Ordering code	Marking	Package	Weight	Base qty	Delivery mode
TPN3021	TPN302	SO-8	0.08g	100	Tube
TPN3021RL <sup>(1)</sup>	TPN302			2500	Tape and reel

1. Preferred device

## 6 Revision history

**Table 8. Document revision history**

Date	Revision	Changes
Sep-2001	3	Previous release
07-Feb-2006	4	Reformatted to current template. Maximum junction temperature parameter replaced by Operating junction temperature range in Table 3. Added footnote 1 to Ordering information table.
25-Jun-2010	5	Updated trademark statement.



**Please Read Carefully:**

Information in this document is provided solely in connection with ST products. STMicroelectronics NV and its subsidiaries ("ST") reserve the right to make changes, corrections, modifications or improvements, to this document, and the products and services described herein at any time, without notice.

All ST products are sold pursuant to ST's terms and conditions of sale.

Purchasers are solely responsible for the choice, selection and use of the ST products and services described herein, and ST assumes no liability whatsoever relating to the choice, selection or use of the ST products and services described herein.

No license, express or implied, by estoppel or otherwise, to any intellectual property rights is granted under this document. If any part of this document refers to any third party products or services it shall not be deemed a license grant by ST for the use of such third party products or services, or any intellectual property contained therein or considered as a warranty covering the use in any manner whatsoever of such third party products or services or any intellectual property contained therein.

**UNLESS OTHERWISE SET FORTH IN ST'S TERMS AND CONDITIONS OF SALE ST DISCLAIMS ANY EXPRESS OR IMPLIED WARRANTY WITH RESPECT TO THE USE AND/OR SALE OF ST PRODUCTS INCLUDING WITHOUT LIMITATION IMPLIED WARRANTIES OF MERCHANTABILITY, FITNESS FOR A PARTICULAR PURPOSE (AND THEIR EQUIVALENTS UNDER THE LAWS OF ANY JURISDICTION), OR INFRINGEMENT OF ANY PATENT, COPYRIGHT OR OTHER INTELLECTUAL PROPERTY RIGHT.**

**UNLESS EXPRESSLY APPROVED IN WRITING BY AN AUTHORIZED ST REPRESENTATIVE, ST PRODUCTS ARE NOT RECOMMENDED, AUTHORIZED OR WARRANTED FOR USE IN MILITARY, AIR CRAFT, SPACE, LIFE SAVING, OR LIFE SUSTAINING APPLICATIONS, NOR IN PRODUCTS OR SYSTEMS WHERE FAILURE OR MALFUNCTION MAY RESULT IN PERSONAL INJURY, DEATH, OR SEVERE PROPERTY OR ENVIRONMENTAL DAMAGE. ST PRODUCTS WHICH ARE NOT SPECIFIED AS "AUTOMOTIVE GRADE" MAY ONLY BE USED IN AUTOMOTIVE APPLICATIONS AT USER'S OWN RISK.**

Resale of ST products with provisions different from the statements and/or technical features set forth in this document shall immediately void any warranty granted by ST for the ST product or service described herein and shall not create or extend in any manner whatsoever, any liability of ST.

ST and the ST logo are trademarks or registered trademarks of ST in various countries.

Information in this document supersedes and replaces all information previously supplied.

The ST logo is a registered trademark of STMicroelectronics. All other names are the property of their respective owners.

© 2010 STMicroelectronics - All rights reserved

STMicroelectronics group of companies

Australia - Belgium - Brazil - Canada - China - Czech Republic - Finland - France - Germany - Hong Kong - India - Israel - Italy - Japan - Malaysia - Malta - Morocco - Philippines - Singapore - Spain - Sweden - Switzerland - United Kingdom - United States of America

[www.st.com](http://www.st.com)

## Данный компонент на территории Российской Федерации

### Вы можете приобрести в компании MosChip.

Для оперативного оформления запроса Вам необходимо перейти по данной ссылке:

<http://moschip.ru/get-element>

Вы можете разместить у нас заказ для любого Вашего проекта, будь то серийное производство или разработка единичного прибора.

В нашем ассортименте представлены ведущие мировые производители активных и пассивных электронных компонентов.

Нашей специализацией является поставка электронной компонентной базы двойного назначения, продукции таких производителей как XILINX, Intel (ex.ALTERA), Vicor, Microchip, Texas Instruments, Analog Devices, Mini-Circuits, Amphenol, Glenair.

Сотрудничество с глобальными дистрибьюторами электронных компонентов, предоставляет возможность заказывать и получать с международных складов практически любой перечень компонентов в оптимальные для Вас сроки.

На всех этапах разработки и производства наши партнеры могут получить квалифицированную поддержку опытных инженеров.

Система менеджмента качества компании отвечает требованиям в соответствии с ГОСТ Р ИСО 9001, ГОСТ РВ 0015-002 и ЭС РД 009

### Офис по работе с юридическими лицами:

105318, г.Москва, ул.Щербаковская д.3, офис 1107, 1118, ДЦ «Щербаковский»

Телефон: +7 495 668-12-70 (многоканальный)

Факс: +7 495 668-12-70 (доб.304)

E-mail: [info@moschip.ru](mailto:info@moschip.ru)

Skype отдела продаж:

moschip.ru

moschip.ru\_4

moschip.ru\_6

moschip.ru\_9