

Features

- Low Voltage Operation: 2.5 V
- Low Harmonics: < -66 dBc at +34 dBm & 1 GHz
- Low Insertion Loss: 0.7 dB at 1 GHz
- High Isolation: 25 dB at 2 GHz
- 0.5 micron GaAs pHEMT Process
- Low Profile, Lead-Free 3 mm PQFN Package
- Halogen-Free "Green" Mold Compound
- RoHS* Compliant and 260°C Re-flow Compatible

Description

M/A-COM's MASW-007813 is a GaAs pHEMT MMIC single pole four throw (SP4T) high power switch in a low cost, low profile, lead-free 3 mm PQFN 16-lead package. The MASW-007813 is ideally suited for applications where high power, low control voltage, low insertion loss, high isolation, small size and low cost are required.

Typical applications are for GSM and DCS handset systems that connect separate transmit and receive functions to a common antenna, as well as CDMA handset and other related applications. The MASW-007813 can be used in all systems operating up to 3 GHz requiring high power at low control voltage.

The MASW-007813 is fabricated using a 0.5 micron gate length GaAs pHEMT process. The process features full passivation for performance and reliability.

Ordering Information ^{1,2}

Part Number	Package
MASW-007813-TR3000	3000 piece reel
MASW-007813-001SMB	Sample Board

1. Reference Application Note M513 for reel size information.
2. All sample boards include 5 loose parts.

* Restrictions on Hazardous Substances, European Union Directive 2002/95/EC.

Functional Schematic

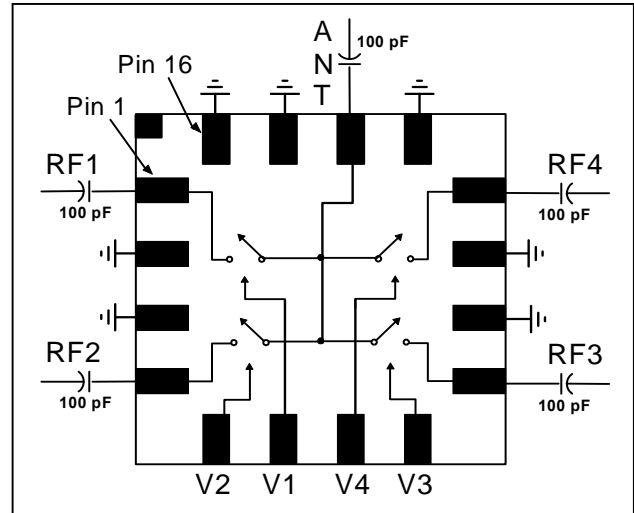

Pin Configuration

Pin No.	Pin Name	Description
1	RF1	RF Port 1
2	GND	RF Ground
3	GND	RF Ground
4	RF2	RF Port 2
5	V2	Control 2
6	V1	Control 1
7	V4	Control 4
8	V3	Control 3
9	RF3	RF Port 3
10	GND	RF Ground
11	GND	RF Ground
12	RF4	RF Port 4
13	GND	RF Ground
14	ANT	Antenna Port
15	GND	RF Ground
16	GND	RF Ground
17	GND (paddle) ³	RF Ground

3. The exposed pad centered on the package bottom must be connected to RF and DC ground.

GaAs SP4T High Power Switch DC - 3 GHz

Rev. V2

Electrical Specifications: $T_A = 25^\circ\text{C}$, $V_C = 0\text{ V} / 2.75\text{ V}$, $P_{IN} = 34\text{ dBm}$, $Z_0 = 50\ \Omega$ ⁴

Parameter	Test Conditions	Units	Min.	Typ.	Max.
Insertion Loss ⁵	DC - 1 GHz	dB	—	0.7	0.85
	1 - 2 GHz		—	0.8	—
	2 - 3 GHz		—	1.0	—
Isolation	DC - 1 GHz	dB	25	33	—
	1 - 2 GHz		—	27	—
	2 - 3 GHz		—	23	—
Return Loss	DC - 3 GHz	dB	—	20	—
P0.1dB	1 GHz	dBm	—	38	—
IP2	Two Tone, +26 dBm/Tone, 5 MHz spacing, > 50 MHz	dBm	—	96	—
IP3	Two Tone, +26 dBm/Tone, 5 MHz spacing, > 50 MHz	dBm	—	58	—
2nd Harmonic	1 GHz, Pin = +34 dBm	dBc	—	-76	-68
3rd Harmonic	1 GHz, Pin = +34 dBm	dBc	—	-68	-66
Trise, Tfall	10% to 90% RF, 90% to 10% RF	ns	—	40	—
Ton, Toff	50% Control to 90% RF, 50% Control to 10% RF	ns	—	110	—
Transients		mV	—	40	—
Control Current	$V_C = 2.75\text{ V}$	μA	—	20	80

4. For positive voltage control, external DC blocking capacitors are required on all RF ports.

5. Insertion loss can be optimized by varying the DC blocking capacitor value, e.g. 1000 pF for 100 MHz - 1 GHz, 39 pF for 0.5 GHz - 3 GHz.

Truth Table^{6,7}

V1	V2	V3	V4	ANT - RF1	ANT - RF2	ANT - RF3	ANT - RF4
1	0	0	0	On	Off	Off	Off
0	1	0	0	Off	On	Off	Off
0	0	1	0	Off	Off	On	Off
0	0	0	1	Off	Off	Off	On

6. Differential voltage, V (state 1) - V (state 0), must be +2.5 V minimum and must not exceed 8.5 V.

7. 0 = -8.5 V to 0 V, 1 = -6 V to 8.5 V

Absolute Maximum Ratings⁸

Parameter	Absolute Maximum
Max Input Power (0.5 - 3 GHz, 2.75 V Control)	+38 dBm
Operating Voltage	+8.5 volts
Operating Temperature	-40°C to +85°C
Storage Temperature	-65°C to +150°C

8. Exceeding any one or combination of these limits may cause permanent damage to this device.

Typical Performance Curves

Insertion Loss

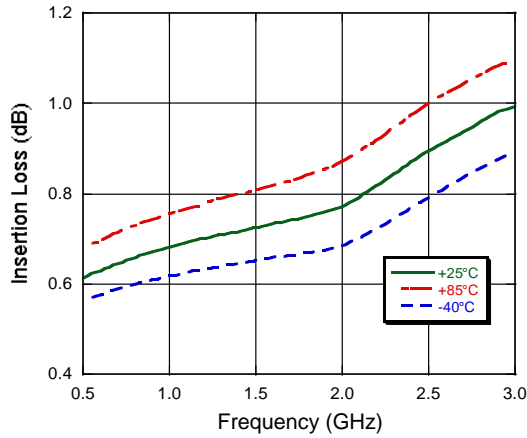

Isolation

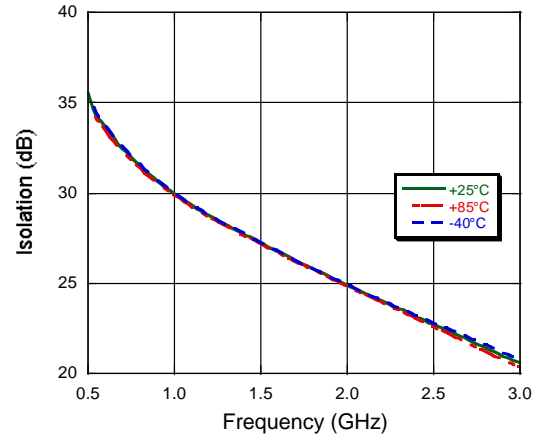

Return Loss

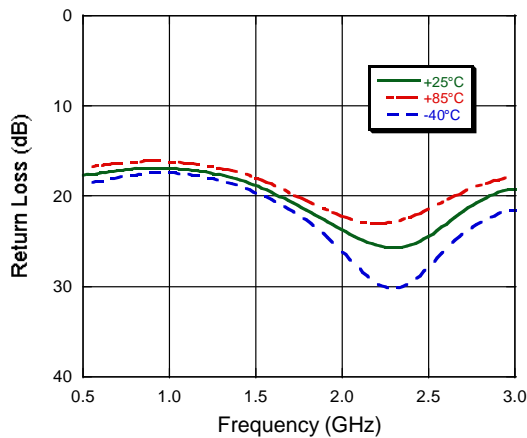

Harmonics vs. Control Voltage, 1 GHz

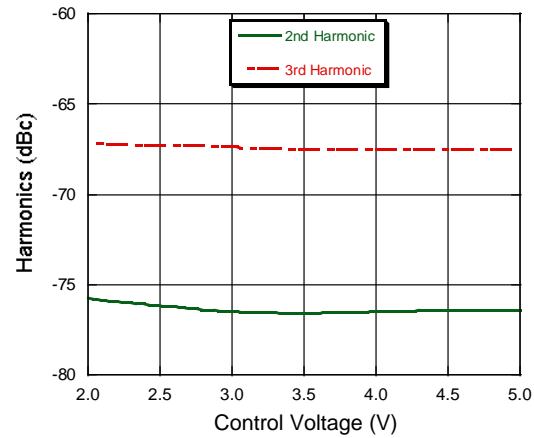

Low Profile, Lead-Free 3 mm 16-lead PQFN †

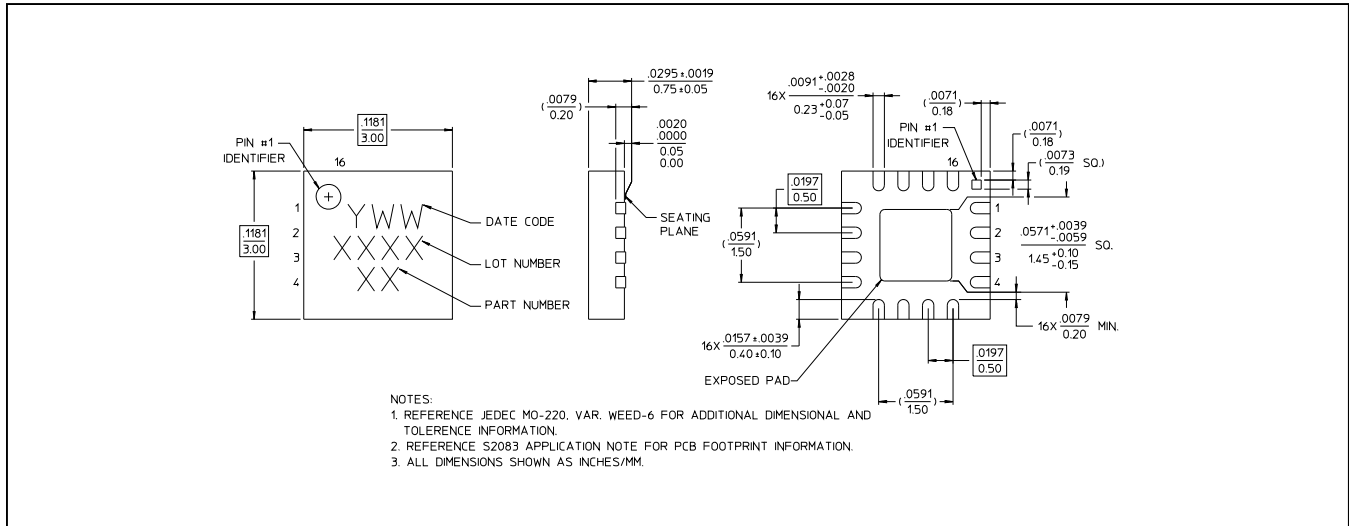

† Reference Application Note M538 for lead-free solder reflow recommendations.
Meets JEDEC moisture sensitivity level 1 requirements.
Plating is 100% matte tin over copper.

Qualification

Qualified to M/A-COM specification REL-201, Process Flow -2.

Handling Procedures

The following precautions should be observed to avoid damage:

Static Sensitivity

Gallium Arsenide Integrated Circuits are sensitive to electrostatic discharge (ESD) and can be damaged by static electricity. Proper ESD control techniques should be used when handling these devices.

Данный компонент на территории Российской Федерации

Вы можете приобрести в компании MosChip.

Для оперативного оформления запроса Вам необходимо перейти по данной ссылке:

<http://moschip.ru/get-element>

Вы можете разместить у нас заказ для любого Вашего проекта, будь то серийное производство или разработка единичного прибора.

В нашем ассортименте представлены ведущие мировые производители активных и пассивных электронных компонентов.

Нашей специализацией является поставка электронной компонентной базы двойного назначения, продукции таких производителей как XILINX, Intel (ex.ALTERA), Vicor, Microchip, Texas Instruments, Analog Devices, Mini-Circuits, Amphenol, Glenair.

Сотрудничество с глобальными дистрибьюторами электронных компонентов, предоставляет возможность заказывать и получать с международных складов практически любой перечень компонентов в оптимальные для Вас сроки.

На всех этапах разработки и производства наши партнеры могут получить квалифицированную поддержку опытных инженеров.

Система менеджмента качества компании отвечает требованиям в соответствии с ГОСТ Р ИСО 9001, ГОСТ РВ 0015-002 и ЭС РД 009

Офис по работе с юридическими лицами:

105318, г.Москва, ул.Щербаковская д.3, офис 1107, 1118, ДЦ «Щербаковский»

Телефон: +7 495 668-12-70 (многоканальный)

Факс: +7 495 668-12-70 (доб.304)

E-mail: info@moschip.ru

Skype отдела продаж:

moschip.ru

moschip.ru_4

moschip.ru_6

moschip.ru_9