



| | | | | | |
|------------------------------|---------------|-------------------------|-----------------|---------------------|---------------|
| <i>Product Specification</i> | <i>Model:</i> | <i>AWT-320240T35N02</i> | <i>Rev. No.</i> | <i>Issued Date.</i> | <i>Page.</i> |
| | | | <i>B</i> | <i>2012/03/05</i> | <i>1 / 20</i> |

LIQUID CRYSTAL DISPLAY MODULE
MODEL: AWT-320240T35N02
Customer's No.:

| |
|------------|
| Acceptance |
| |

10 -1 Floor, No.192, Tahtung Road,
 Sec. 3, Hsi-Chih City,
 Taipei Hsien, Taiwan

| |
|-------------------------|
| Approved and Checked by |
| |

| Approved by | Checked by | Made by |
|---|--|--|
|  2012/03/05 NICK |  2012/03/05 JOE |  2012/03/05 TOM |

| | | | | | |
|------------------------------|---------------|-------------------------|-----------------|---------------------|---------------|
| <i>Product Specification</i> | <i>Model:</i> | <i>AWT-320240T35N02</i> | <i>Rev. No.</i> | <i>Issued Date.</i> | <i>Page.</i> |
| | | | <i>B</i> | <i>2012/03/05</i> | <i>2 / 20</i> |

Contents

| | |
|--|----|
| 1. General Description | 3 |
| 2. Physical Features | 3 |
| 3. Mechanical Specification | 3 |
| 4. Outline Dimension | 4 |
| 5. Absolute Maximum Ratings | 5 |
| 6. Electrical Characteristics | 5 |
| 7. Module Function Description | 6 |
| 8. Backlight Characteristics..... | 9 |
| 9. Electro-Optical Characteristics..... | 10 |
| 10. Reliability | 12 |
| 11. Inspection Standards | 13 |
| 12. Precautions For Using LCD Modules..... | 19 |
| 13. Records Of Version..... | 20 |

| | | | | | |
|------------------------------|---------------|-------------------------|-----------------|---------------------|---------------|
| <i>Product Specification</i> | <i>Model:</i> | <i>AWT-320240T35N02</i> | <i>Rev. No.</i> | <i>Issued Date.</i> | <i>Page.</i> |
| | | | <i>B</i> | <i>2012/03/05</i> | <i>3 / 20</i> |

1. General Description

AWT-320240T35N02 is a transmissive type a-Si TFT-LCD (amorphous silicon thin film transistor liquid crystal display) module, which is composed of a TFT-LCD panel, a driver circuit and a backlight unit. The panel size is 3.5 inch and the resolution is 320x240, the panel can display up to 262K colors. The LCM can be easily accessed by micro-controller via parallel interface.

2. Physical Features

| | |
|-------------------|--|
| Display Mode | TFT-LCD Module |
| | Active matrix TFT, Transmissive type |
| Display Format | Graphic 320×RGB×240 Dot-matrix |
| Input Data | 24 bit RGB with Serial Interface\CCIR656 |
| Viewing Direction | 6 O'clock |
| Drive | HX8238-A |

3. Mechanical Specification

| Item | Contents | Unit |
|---------------------|-------------------|------|
| Module size (W×H×T) | 63.9 × 76.9 × 3.3 | mm |
| Number of dots | 320(RGB) × 240 | --- |
| Active area (W×H) | 70.08 × 52.56 | mm |

| | | | | | |
|-----------------------|--------|------------------|----------|--------------|--------|
| Product Specification | Model: | AWT-320240T35N02 | Rev. No. | Issued Date. | Page. |
| | | | B | 2012/03/05 | 4 / 20 |

4.Outline

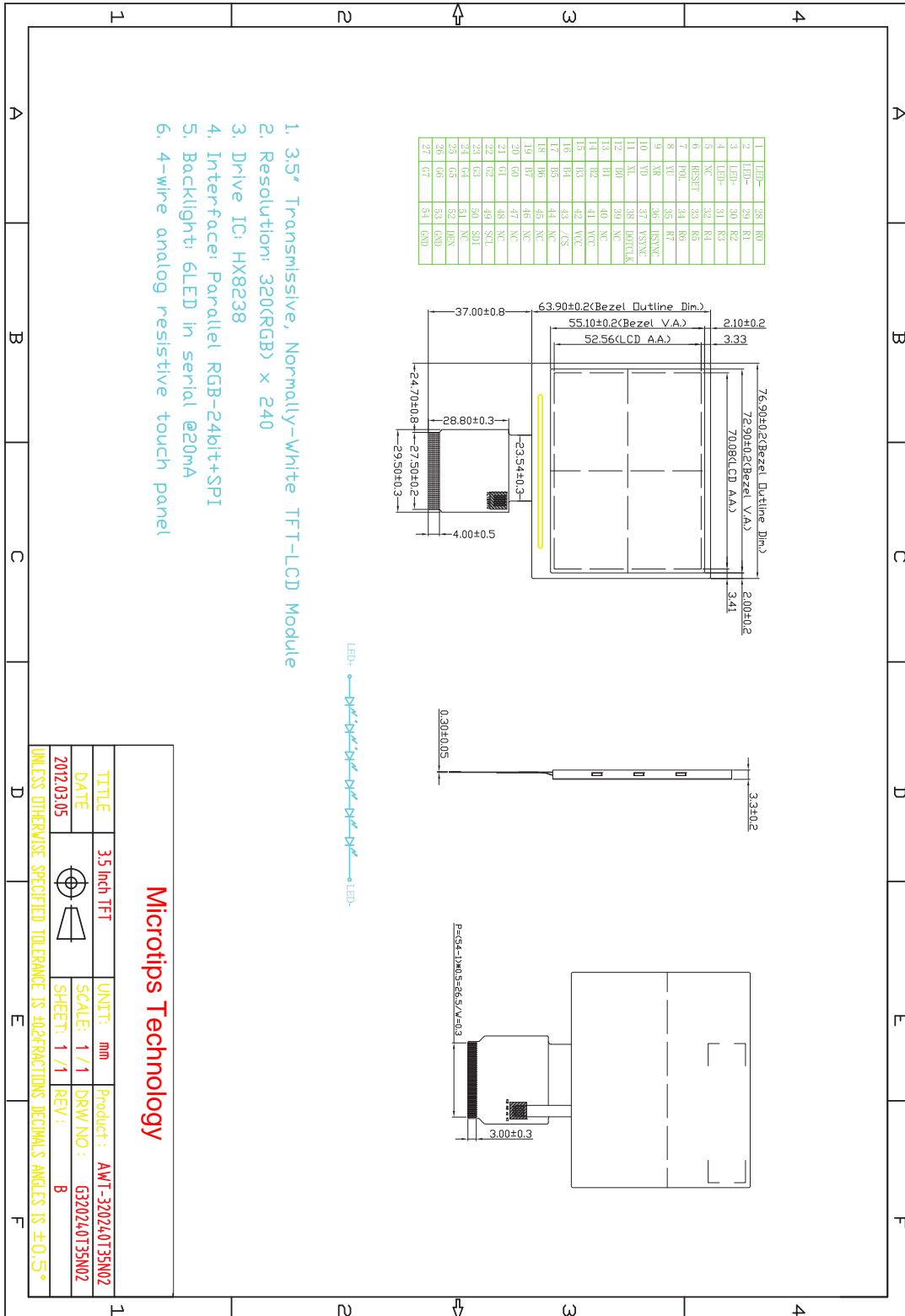

| | | | | | |
|-----------------------|--------|------------------|----------|--------------|--------|
| Product Specification | Model: | AWT-320240T35N02 | Rev. No. | Issued Date. | Page. |
| | | | B | 2012/03/05 | 5 / 20 |

5. Absolute Maximum Ratings

| Item | Symbol | Min | Max | Unit | Remark |
|-----------------------|--------|------|---------|------|-----------------|
| Power Voltage | VCC | -0.3 | 3.6 | V | Note1、 Note2 |
| Input Voltage | VIN | -0.3 | VCC+0.3 | V | |
| Operating temperature | TOPR | -20 | 70 | °C | |
| Storage temperature | TSTR | -30 | 80 | °C | |
| Humidity | --- | --- | 90 | %RH | --- |

Remark:

Note 1) The HX8238 may be permanently damaged if it is used under the condition exceeding the above absolute maximum values. It is also recommended to use the HX8238 within the limit of its electric characteristics during normal operation. Exceeding the conditions may lead to malfunction of HX8238 and affect its credibility.

Note 2) The voltage from VSS.

6. Electrical Characteristics

| Item | | Symbol | Rating | | | Unit | Remark |
|-------------------------|---------|--------|----------|------|---------|------|-------------------|
| | | | Min | Typ | Max | | |
| Power Voltage | Logic | VCC | 2.5 | 3.3 | 3.6 | V | Note1 |
| Input Voltage | L level | VIL | -0.3 | ---- | 0.2*VCC | V | VCC=2.5 ~ 3.6V |
| | H level | VIH | 0.8* VCC | --- | --- | V | |
| LCD Drive Power current | | ILCD | --- | --- | 15 | mA | --- |

Remark:

Note1:Vcom must be adjusted to optimize display quality: Cross-talk, Contrast Ratio and etc.

| | | | | | |
|------------------------------|---------------|-------------------------|-----------------|---------------------|---------------|
| <i>Product Specification</i> | <i>Model:</i> | <i>AWT-320240T35N02</i> | <i>Rev. No.</i> | <i>Issued Date.</i> | <i>Page.</i> |
| | | | <i>B</i> | <i>2012/03/05</i> | <i>6 / 20</i> |

7. Module Function Description

7-1. Block Diagram Of LCM

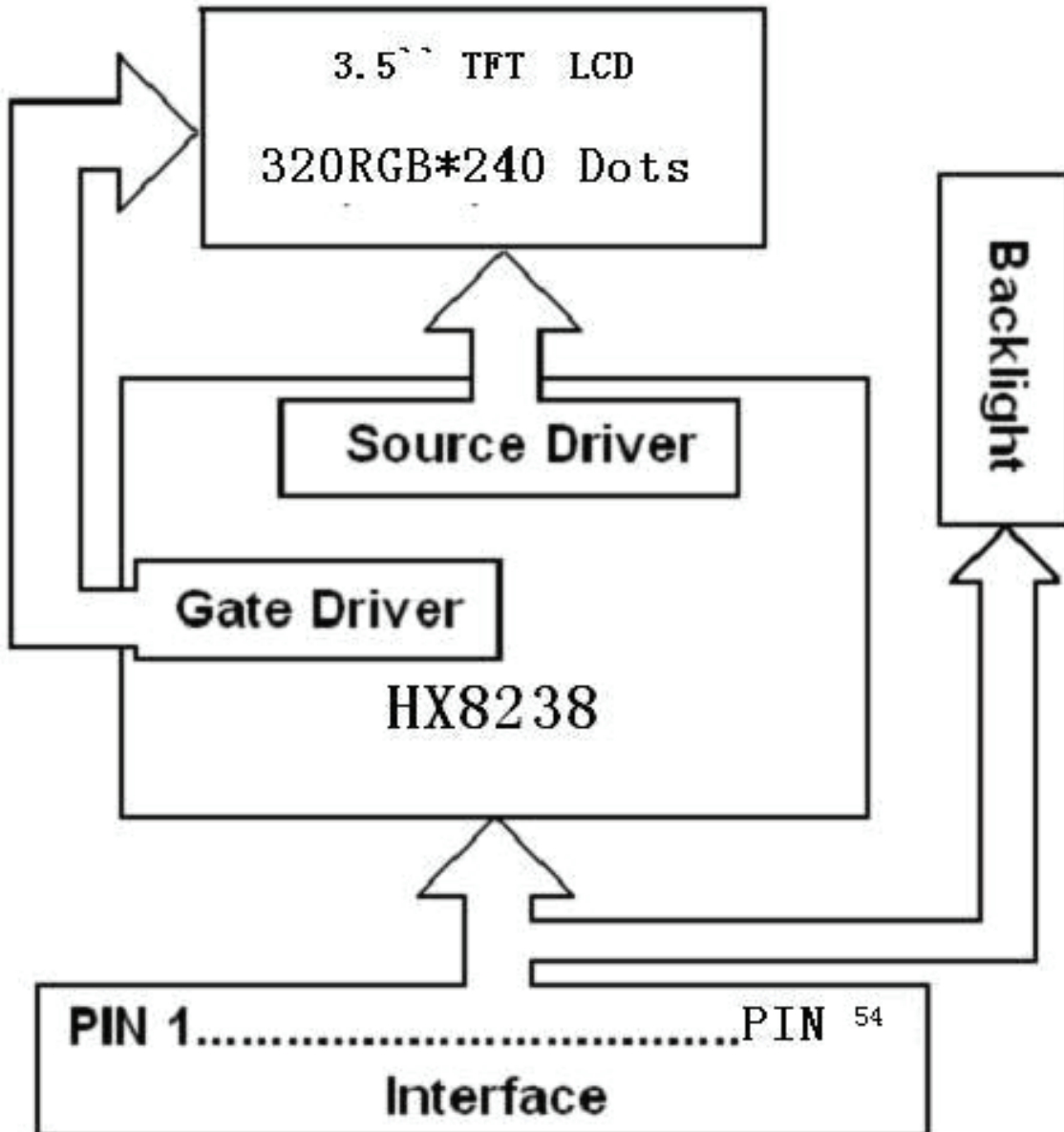

| | | | | | |
|------------------------------|---------------|-------------------------|-----------------|---------------------|---------------|
| <i>Product Specification</i> | <i>Model:</i> | <i>AWT-320240T35N02</i> | <i>Rev. No.</i> | <i>Issued Date.</i> | <i>Page.</i> |
| | | | <i>B</i> | <i>2012/03/05</i> | <i>7 / 20</i> |

7-2. Pin Description

| NO. | Symbol | Function |
|-------|-----------|------------------------------------|
| 1-2 | LED-K | CATHODE OF BACKLIGHT LED |
| 3-4 | LED-A | ANODE OF BACKLIGHT LED |
| 5 | NC | DUMMY PIN |
| 6 | /RESET | SYSTEM Reset |
| 7 | NC | DUMMY PIN |
| 8 | NC | NC |
| 9 | NC | |
| 10 | NC | |
| 11 | NC | |
| 12-35 | DB00-DB23 | PARALLE RGB Data BUS |
| 36 | HSYNC | Line synchronization signal |
| 37 | VSYNC | Frame synchronization signal |
| 38 | DCLK | DOTCLK |
| 39 | NC | DUMMY PINS |
| 40 | NC | DUMMY PINS |
| 41 | VCC | SYSTEM VCC |
| 42 | VCC | SYSTEM VCC |
| 43 | SPENA | SPI ENABLE |
| 44-47 | NC | DUMMY PINS |
| 48 | GND | SYSTEM GND |
| 49 | SPCLK | SERIAL CLOCK SIGNAL |
| 50 | SPDAT | SERIAL DATA SIGNAL |
| 51 | NC | DUMMY PINS |
| 52 | DEN | Display enable pin from controller |
| 53 | GND | SYSTEM GND |
| 54 | GND | SYSTEM GND |

| | | | | | |
|-----------------------|--------|------------------|----------|--------------|--------|
| Product Specification | Model: | AWT-320240T35N02 | Rev. No. | Issued Date. | Page. |
| | | | B | 2012/03/05 | 8 / 20 |

7-3. Timing Characteristics

7.3.1 RGB Interface Timing Characteristics

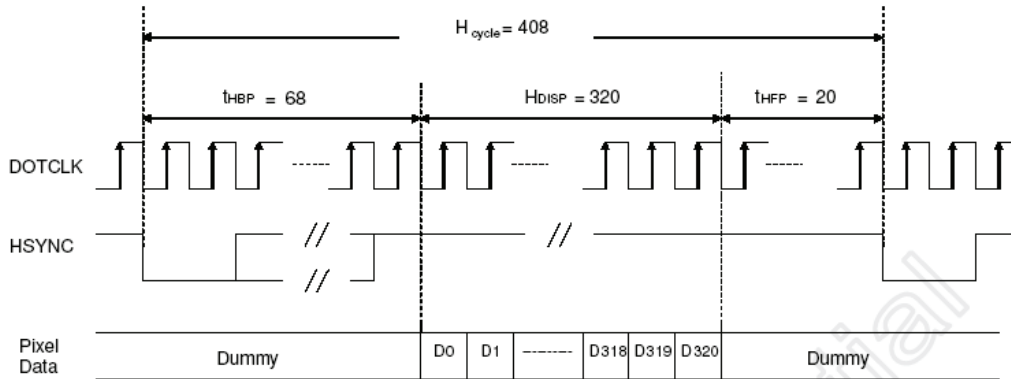

a) Horizontal Data Transaction Timing

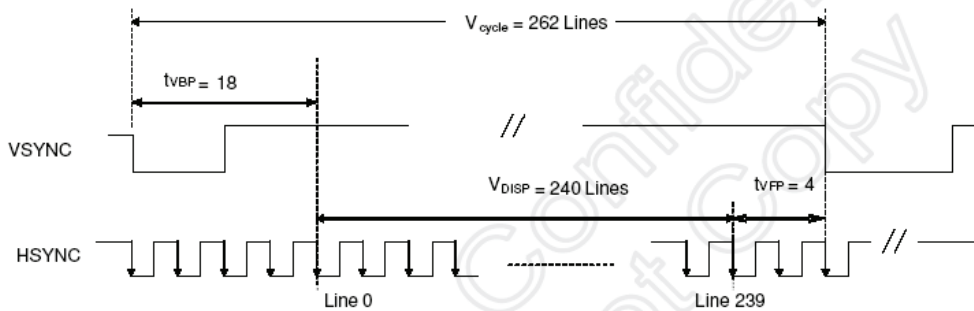

VCC=2.5~3.3V , Ta=25°C

| Signal | Symbol | Parameter | Min. | Max. | Unit | description |
|--------|-------------|-----------------------------|------|------|------|----------------------|
| RS | t_{AST} | Address setup time | 10 | - | ns | - |
| | t_{AHT} | Address hold time | 10 | - | | |
| /CS | t_{CHW} | Chip select 'H' pulse width | 0 | - | ns | - |
| | t_{TCS} | Chip select setup time | 35 | - | | |
| | t_{RCSFM} | Chip select setup time | 355 | - | | |
| | t_{CSF} | Chip select wait time | 10 | - | | |
| | t_{CSH} | Chip select hold time | 10 | - | | |
| /WR | t_{WC} | Write cycle | 100 | - | ns | - |
| | t_{WRH} | Control pulse 'H' duration | 35 | - | | |
| | t_{WRL} | Control pulse /L/ duration | 35 | - | | |
| /RD | t_{RCFM} | Read cycle | 450 | - | ns | When read from GRAM. |
| | t_{RDHFM} | Control pulse 'H' duration | 90 | - | | |
| | t_{RDLFM} | Control pulse 'L' duration | 355 | - | | |
| DB0~15 | t_{DST} | Data setup time | 15 | - | ns | - |
| | t_{DHT} | Data hold time | 10 | - | | |
| | t_{RATFM} | Read access time | - | 340 | | |
| | t_{ODH} | Output disable time | 20 | 80 | | |

| | | | | | |
|-----------------------|--------|------------------|----------|--------------|--------|
| Product Specification | Model: | AWT-320240T35N02 | Rev. No. | Issued Date. | Page. |
| | | | B | 2012/03/05 | 9 / 20 |

8. Backlight Characteristics

| Item | Symbol | Min | Typ | Max | Unit | Remark |
|-----------------|----------|------|------|------|-------------------|--------|
| Forward voltage | V_{BL} | 18 | 19.2 | 20 | V | - |
| Current | I_{BL} | - | 15 | - | mA/chip | - |
| ICE | X | 0.26 | - | 0.32 | - | - |
| | Y | 0.26 | - | 0.32 | - | |
| Brightness | - | 2600 | - | - | cd/m ² | ★1 |
| Uniformity | - | 80 | - | - | % | ★2 |

★1 Test condition is :

- (a) Center point on active area
- (b) Best Contrast

★2 Uniform measure condition :

- (1) Measure 9 point. Measure location is show below :
- (2) Uniform = (Min. brightness / Max. brightness) × 100%
- (3) Best Contrast.

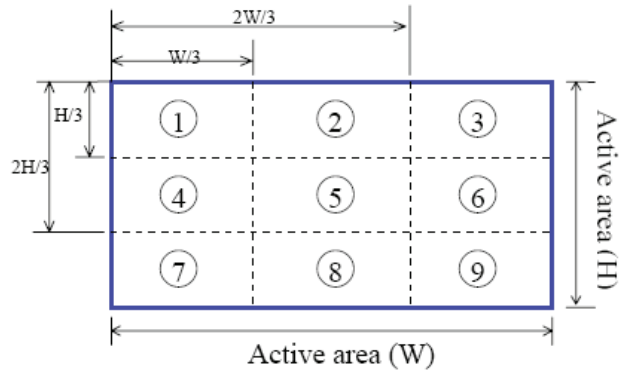

| | | | | | |
|-----------------------|--------|------------------|----------|--------------|---------|
| Product Specification | Model: | AWT-320240T35N02 | Rev. No. | Issued Date. | Page. |
| | | | B | 2012/03/05 | 10 / 20 |

9. Electro-Optical Characteristics

| Item | Symbol | Condition | Min. | Typ. | Max. | Unit | Remark |
|--------------------|--------|---------------|-------|-------|-------|------|----------------|
| Response time | Tr +Tf | | --- | 50 | 70 | ms | Reference Only |
| Contrast Ratio | CR | | 150 | 250 | --- | --- | |
| Transmittance | T% | | --- | 6.3 | --- | % | |
| Color chromaticity | white | Wx | 0.264 | 0.294 | 0.324 | - | |
| | | Wy | 0.304 | 0.334 | 0.364 | | |
| | Red | Rx | 0.603 | 0.633 | 0.663 | | |
| | | Ry | 0.296 | 0.326 | 0.356 | | |
| | Green | Gx | 0.267 | 0.297 | 0.327 | | |
| | | Gy | 0.547 | 0.577 | 0.607 | | |
| | Blue | Bx | 0.103 | 0.133 | 0.163 | | |
| | | By | 0.099 | 0.129 | 0.159 | | |
| Viewing angle | Hor. | θ_{x+} | --- | 45 | --- | Deg. | |
| | | θ_{x-} | --- | 45 | --- | | |
| | Ver. | θ_{y+} | --- | 35 | --- | | |
| | | θ_{y-} | --- | 15 | --- | | |

Note (1) Definition of Viewing Angle θ_x and θ_y :

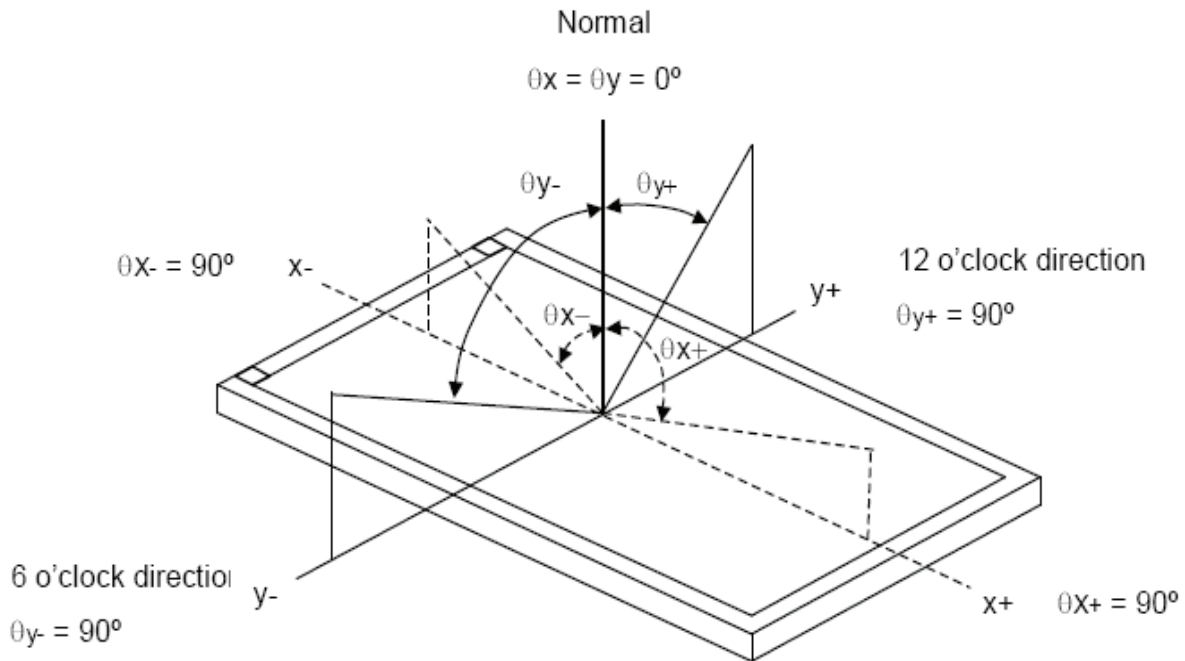

| | | | | | |
|-----------------------|--------|------------------|----------|--------------|---------|
| Product Specification | Model: | AWT-320240T35N02 | Rev. No. | Issued Date. | Page. |
| | | | B | 2012/03/05 | 11 / 20 |

Note (2) Definition of Contrast Ratio(CR) :
measured at the center point of panel

$$CR = \frac{\text{Luminance with all pixels white}}{\text{Luminance with all pixels black}}$$

Note (3) Definition of Response Time : Sum of T_R and T_F

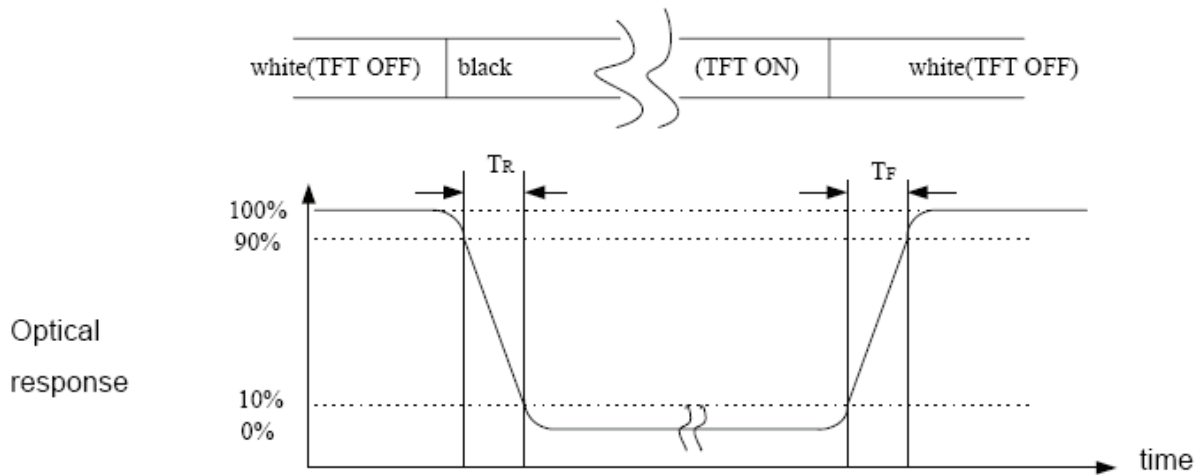

Note (4) Definition of optical measurement setup

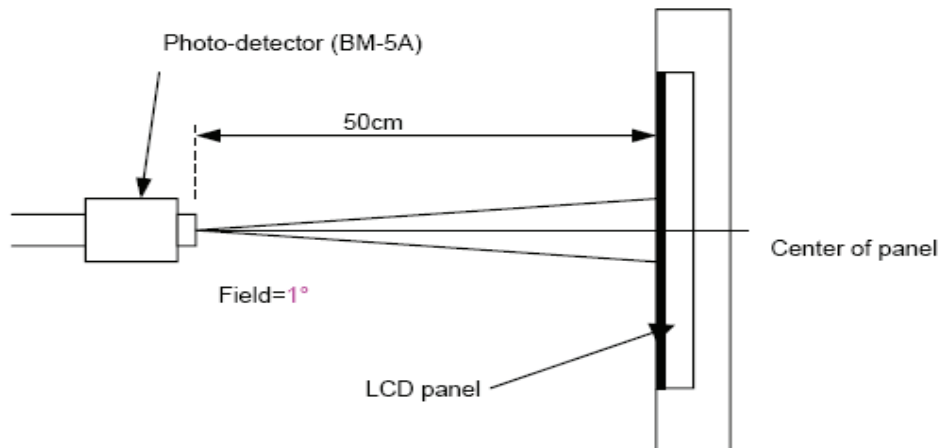

| | | | | | |
|------------------------------|---------------|-------------------------|-----------------|---------------------|----------------|
| <i>Product Specification</i> | <i>Model:</i> | <i>AWT-320240T35N02</i> | <i>Rev. No.</i> | <i>Issued Date.</i> | <i>Page.</i> |
| | | | <i>B</i> | <i>2012/03/05</i> | <i>12 / 20</i> |

10. Reliability

10.1. MTBF

The LCD module shall be designed to meet a minimum MTBF value of 50000 hours with normal. (25°C in the room without sunlight)

10.2. Test condition

| NO. | ITEM | CONDITION | CRITERION |
|-----|--|---|---|
| 1 | High Temperature Non-Operating Test | 80°C * 240Hrs | <ul style="list-style-type: none"> ◦ No Defect Of Operational Function In Room Temperature Are Allowable. ◦ IDD of LCM in Pre-and Post-Test Should Follow Specification |
| 2 | Low Temperature Non-Operating Test | -30°C * 240Hrs | |
| 3 | High Temperature/Humidity Non-Operating Test | 50°C * 90%RH * 240 Hrs | |
| 4 | High Temperature Operating Test | 70°C * 240Hrs | |
| 5 | Low Temperature Operating Test | -20°C * 240Hrs | |
| 6 | Thermal Shock Test | -30°C (30Min) ↔ 80(30Min)* 10 Cycles | |

Notes:

1. Judgments should be made after exposure in room temperature for two hours.
2. The distill water is used for the high temperature / humidity test.
3. The sample above is individually for every reliability tests condition.

| | | | | | |
|-----------------------|--------|------------------|----------|--------------|---------|
| Product Specification | Model: | AWT-320240T35N02 | Rev. No. | Issued Date. | Page. |
| | | | B | 2012/03/05 | 13 / 20 |

11. Inspection Standards

1. AQL(Acceptable Quality Level)
AQL of major and minor defect

| | MAJOR DEFECT | MINOR DEFECT | MAJOR+MINOR |
|------------------|--------------|--------------|-------------|
| APPEARANCE | 0.40% | 1.0% | 1.0% |
| ELECTRIC-OPTICAL | 0.15% | 0.15% | 0.15% |

2. Basic conditions for inspection

The LCM face to us, in normal environment, the lux is 1000 ± 200 . (Darkroom's lux: 100 ± 50),

About an angle of incidence 30, a distance of 30cm with normal eye, with an angle of 45 degree to check the products without uncovering the film!

(As shown below)

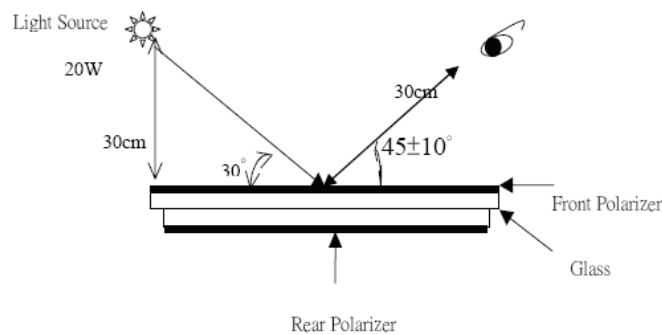

3. Inspection item and criteria

3.1 Visual inspection criterion in immobility

3.1.1 Glass defect

| No | Defect item | Criteria | Remark |
|----|--|------------------------|--------|
| 1 | Dimension Unconformity (Major defect) | By Engineering Drawing | |

| | | | | | |
|-----------------------|--------|------------------|----------|--------------|---------|
| Product Specification | Model: | AWT-320240T35N02 | Rev. No. | Issued Date. | Page. |
| | | | B | 2012/03/05 | 14 / 20 |

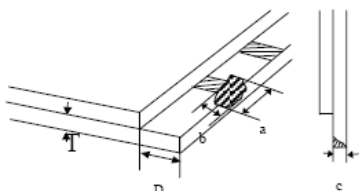
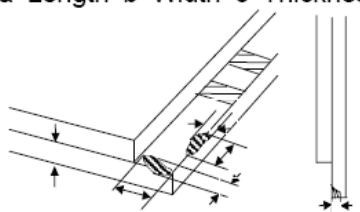
| No | Defect item | Criteria | Remark |
|----|--|--|---|
| 2 | Cracks (Major defect) | 1.Linear cracks on panel 【Reject】 2. Nonlinear crack contrast by limited sample | |
| 3 | Glass extrude the conductive area (minor defect) | a: disregards and no influence assemblage 1) $b \leq 1/3$ Pin width(non bonding area) 【Accept】 2) bonding area ≤ 0.5 mm 【Accept】 | a:Length, b:Width |
| 4 | Pin-side · conductive area damaged (minor defect) | (a c : disregards) $b \leq 1/3$ of effective length for bonding electrode 【Accept】 | a : Length · b : Width · c : Thickness  |
| 5 | Pin-side · non-conductive area damaged (minor defect) | 1) Damage area don't touch the ITO (Including contraposition mark,except scribing mark) 【Accept】 2) $c < T$ $b \leq BM$ 1/3 of width 【Accept】 3) $c = T$ b not touch the seal glue 【Accept】 4) a disregards | a : Length · b : Width · c : Thickness  |

| | | | | | |
|-----------------------|--------|------------------|----------|--------------|---------|
| Product Specification | Model: | AWT-320240T35N02 | Rev. No. | Issued Date. | Page. |
| | | | B | 2012/03/05 | 15 / 20 |

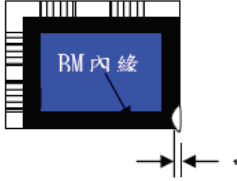
| No | Defect item | Criteria | Remark |
|----|---|---|--|
| 6 | Non-pin-side damage (minor defect) | c<T 1) b exceeds 1/3 BM 【Reject】 | c : Thickness b: width of damage  |
| | | c=T b not touch the seal glue 【Reject】 | |

3.1.2 LCD appearance defect (View area)

| No | Defect item | Criteria | Remark |
|----|--|-----------------------------------|-----------|
| 1 | Fiber · glass crack · polarizer scratch/folded (minor defect) | Specification | Allowable |
| | | 0.05mm<W ≤ 0.1mm; L ≤ 3.0mm | 1 |
| | | W>0.1mm ; L>3.0mm | 0 |
| 2 | Polarizer bubble · concave and convex (minor defect) | $\psi \leq 0.2\text{mm}$ | disregard |
| | | 0.2mm< $\psi \leq 0.3\text{mm}$ | 2 |
| | | 0.3mm< $\psi \leq 0.5\text{mm}$ | 1 |
| | | 0.5mm< ψ | 0 |
| 3 | Black dots · dirty dots · impurities · eyewinker (Major defect) | $\psi \leq 0.15\text{mm}$ | disregard |
| | | 0.15mm< $\psi \leq 0.25\text{mm}$ | 2 |
| | | 0.25mm< $\psi \leq 0.3\text{mm}$ | 1 |
| | | 0.3mm< ψ | 0 |
| 4 | Polarizer prick (Major defect) | $\psi \leq 0.1\text{mm}$ | disregard |
| | | 0.1mm< $\psi \leq 0.25\text{mm}$ | 3 |
| | | $\psi > 0.25\text{mm}$ | 0 |

| | | | | | |
|-----------------------|--------|------------------|----------|--------------|---------|
| Product Specification | Model: | AWT-320240T35N02 | Rev. No. | Issued Date. | Page. |
| | | | B | 2012/03/05 | 16 / 20 |

3.1.3 .FPC

| No | Defect item | Criteria | | Remark |
|----|--|---------------------------|-------------------|---|
| 1 | Copper screen peel (Major defect) | Copper screen peel | 【 Reject 】 | |
| 2 | No release tape or peel (Major defect) | No release tape or peel | 【 Reject 】 | |
| 3 | Dirty dot and impurity of FPC for customer using side (minor defect) | Specification | Allowable | note1: Cannot have stride ITO impurities |
| | | $\psi \leq 0.25\text{mm}$ | 2 | |
| | | $\psi > 0.25$ | 0 | |

3.1.4 Black tape & Mara tape

| | | | |
|---|--|---|--|
| 1 | FPC or H/S black tape shift (minor defect) | 1.shift spec: 1)glue to the polarize 【 Reject 】 2) IC bare 【 Reject 】 2. left-and-right spec: 1) exceed of FPC edge or H-S edge 【 Reject 】 2)IC bare 【 Reject 】 | |
| 2 | No black tape (Major defect) | No black tape 【 Reject 】 | |
| 3 | Tape position mistake (minor defect) | Not by engineering drawing 【 Reject 】 | |
| 4 | Mara tape defect (minor defect) | Peel before pulling the protecting film. 【 Reject 】 | |

3.1.5 Silicon and Tuffy glue

| No | Defect item | Criteria | Remark |
|----|---------------------------------------|--|---|
| 1 | Quantity of silicon (minor defect) | Uncover the ITO and circuit area. 【 Reject 】 | note: compared by engineering drawing. |

| | | | | | |
|-----------------------|--------|------------------|----------|--------------|---------|
| Product Specification | Model: | AWT-320240T35N02 | Rev. No. | Issued Date. | Page. |
| | | | B | 2012/03/05 | 17 / 20 |

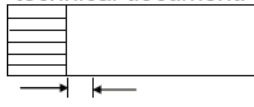
| No | Defect item | Criteria | Remark |
|----|--|---|--|
| 2 | Tuffy glue (minor defect) | 1. Uncover the reveal copper area 【 Reject】 2. Cover layer 0.3mm(Min) ~ 3.0mm(Max) 【 accept】 | note:if customer has special requirement , refer to the technical document.  |
| 3 | Depth of glue covering (minor defect) | Depth of glue covering ovetop front Polarizer 【 Reject】 | Except of the special requirement ° |

3.2 Electrical criteria

| No | Defect item | Criteria | Remark |
|----|--|---|-------------------|
| 1 | No display (Major defect) | No display 【 Reject】 | |
| 2 | Missing line (Major defect) | Missing line 【 Reject】 | |
| 3 | Seg-com light and dark (Major defect) | Seg-com light and dark 【 Reject】 | ND filter 2% test |
| 4 | No display in immobility (Major defect) | No display in immobility 【 Reject】 | |
| 5 | Flicker of Pattern (Major defect) | Flicker of Pattern 【 Reject】 | |
| 6 | Mura (Major defect) | ND filter 2% test | |
| 7 | Over current (Major defect) | Over current 【 Reject】 | |
| 8 | Voltage out of specification (Major defect) | Voltage out of specification 【 Reject】 | |
| 9 | Pattern blur ,error code (Major defect) | Pattern blur ,error code 【 Reject】 | |
| 10 | Dark light, Flicker (Major defect) | Dark light, Flicker 【 Reject】 | |

| | | | | | |
|-----------------------|--------|------------------|----------|--------------|---------|
| Product Specification | Model: | AWT-320240T35N02 | Rev. No. | Issued Date. | Page. |
| | | | B | 2012/03/05 | 18 / 20 |

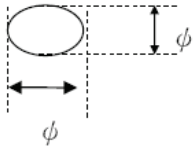
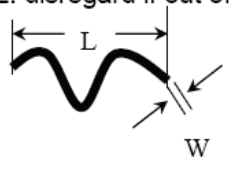
| No | Defect item | Criteria | Allowable | Remark |
|----|---|---|-----------|---|
| 11 | Black/White dots · Dirty dots · eyewinker (Major defect) | Specification | Allowable | Note1: disregard if out of AA  |
| | | $\psi \leq 0.15\text{mm}$ | disregard | |
| | | $0.15\text{mm} < \psi \leq 0.25\text{mm}$ | 2 | |
| | | $0.25\text{mm} < \psi \leq 0.3\text{mm}$ | 1 | |
| | | $0.3\text{mm} < \psi$ | 0 | |
| 12 | Fiber · glass cratch · polarizer scratch/folded (minor defect) | $W \leq 0.03\text{mm}$ | disregard | note1: L : Length · W : Width note2: disregard if out of AA  |
| | | $0.03\text{mm} < W \leq 0.05\text{mm}$; $L \leq 3.0\text{mm}$ | 2 | |
| | | $0.05\text{mm} < W \leq 0.1\text{mm}$; $L \leq 3.0\text{mm}$ | 1 | |
| | | $W > 0.1\text{mm}$; $L > 3.0\text{mm}$ | 0 | |

| | | | | | |
|------------------------------|---------------|-------------------------|-----------------|---------------------|----------------|
| <i>Product Specification</i> | <i>Model:</i> | <i>AWT-320240T35N02</i> | <i>Rev. No.</i> | <i>Issued Date.</i> | <i>Page.</i> |
| | | | <i>B</i> | <i>2012/03/05</i> | <i>19 / 20</i> |

12. Precautions For Using LCD Modules

Please pay attentions to the followings as using the LCD module.

12.1 Handling

- (a) Do not apply strong mechanical stress like drop, shock or any force to LCD module. It may cause improper operation, even damage.
- (b) Because the ITO film very fragile and easy to be damaged, do not hit, press or rub the display surface with hard materials.
- (c) Do not put heavy or hard material on the display surface, and do not stack LCD modules.
- (d) If the display surface is dirty, please wipe the surface softly with cotton swab or clean cloth.
- (e) Wipe off water droplets or oil immediately.
- (f) Protect the LCD module from ESD. It will damage the LSI and the electronic circuit.
- (g) Do not touch the output pins directly with bare hands.
- (h) Do not disassemble the LCD module.

12.2 Storage

- (a) Do not leave the LCD modules in high temperature, especially in high humidity for a long time.
- (b) Do not expose the LCD modules to sunlight directly.
- (c) The liquid crystal is deteriorated by ultraviolet. Do not leave it in strong ultraviolet ray for a long time.
- (d) Avoid condensation of water. It may cause improper operation.
- (e) Please stack only up to the number stated on carton box for storage and transportation. Excessive weight will cause deformation and damage of carton box.

12.3 Operation

- (a) When mounting or dismounting the LCD modules, turn the power off.
- (b) Protect the LCD modules from electric shock.
- (c) The Driver IC control algorithms stated above should always obeyed to avoid damaging the LSI and electronic circuit.
- (d) Be careful to avoid mixing up the polarity of power supply for backlight.

| | | | | | |
|------------------------------|---------------|------------------|-----------------|---------------------|--------------|
| <i>Product Specification</i> | <i>Model:</i> | AWT-320240T35N02 | <i>Rev. No.</i> | <i>Issued Date.</i> | <i>Page.</i> |
| | | | B | 2012/03/05 | 20 / 20 |

- (e) Absolute maximum rating specified above has to be always kept in any case. Exceeding it may cause non-recoverable damage of electronic components or, nevertheless, burning.
- (f) When a static image is displayed for a long time, remnant image is likely to occur.
- (g) Be sure to avoid bending the FPC to an acute shape, it might break FPC.

12.4 Others

- (a) If the liquid crystal leaks from the panel, it should be kept away from the eyes or mouth.
- (b) It is recommended to peel off the protection film on the ITO film slowly so that the electrostatic charge can be minimized.
- (c) It is recommended to peel off the protection film on the polarizer slowly so that the electrostatic charge can be minimized.

13. Records Of Version

| Version | Revise Date | Page | Content |
|---------|-------------|------|--------------------------------|
| A | 2009-11-23 | All | FIRST ISSUE |
| B | 2012-03-05 | 4 | Change the rib length on frame |
| | | | |
| | | | |
| | | | |
| | | | |
| | | | |
| | | | |
| | | | |
| | | | |
| | | | |
| | | | |
| | | | |

Данный компонент на территории Российской Федерации

Вы можете приобрести в компании MosChip.

Для оперативного оформления запроса Вам необходимо перейти по данной ссылке:

<http://moschip.ru/get-element>

Вы можете разместить у нас заказ для любого Вашего проекта, будь то серийное производство или разработка единичного прибора.

В нашем ассортименте представлены ведущие мировые производители активных и пассивных электронных компонентов.

Нашей специализацией является поставка электронной компонентной базы двойного назначения, продукции таких производителей как XILINX, Intel (ex.ALTERA), Vicor, Microchip, Texas Instruments, Analog Devices, Mini-Circuits, Amphenol, Glenair.

Сотрудничество с глобальными дистрибьюторами электронных компонентов, предоставляет возможность заказывать и получать с международных складов практически любой перечень компонентов в оптимальные для Вас сроки.

На всех этапах разработки и производства наши партнеры могут получить квалифицированную поддержку опытных инженеров.

Система менеджмента качества компании отвечает требованиям в соответствии с ГОСТ Р ИСО 9001, ГОСТ РВ 0015-002 и ЭС РД 009

Офис по работе с юридическими лицами:

105318, г.Москва, ул.Щербаковская д.3, офис 1107, 1118, ДЦ «Щербаковский»

Телефон: +7 495 668-12-70 (многоканальный)

Факс: +7 495 668-12-70 (доб.304)

E-mail: info@moschip.ru

Skype отдела продаж:

moschip.ru

moschip.ru_4

moschip.ru_6

moschip.ru_9