

**ebm-papst Mulfingen GmbH & Co. KG**

Bachmühle 2 · D-74673 Mulfingen

Phone +49 7938 81-0

Fax +49 7938 81-110

info1@de.ebmpapst.com

www.ebmpapst.com

Limited partnership · Headquarters Mulfingen

County court Stuttgart · HRA 590344

General partner Elektrobau Mulfingen GmbH · Headquarters Mulfingen

County court Stuttgart · HRB 590142

**Nominal data**

<b>Type</b>	<b>S4D350-AN22-67</b>			
<b>Motor</b>	<b>M4D074-DF</b>			
Phase		3~	3~	3~
Nominal voltage	VAC	400	400	480
Connection		Y	Y	Y
Frequency	Hz	50	60	60
Type of data definition		ml	ml	ml
Valid for approval / standard		CE	CE	CE
Speed	min <sup>-1</sup>	930	830	990
Power input	W	95	100	135
Current draw	A	0.16	0.17	0.18
Max. back pressure	Pa	40	30	42
Min. ambient temperature	°C	-40	-40	-40
Max. ambient temperature	°C	80	65	55

ml = Max. load · me = Max. efficiency · fa = Running at free air · cs = Customer specs · cu = Customer unit  
Subject to alterations



### Technical features

<b>Mass</b>	4.66 kg
<b>Size</b>	350 mm
<b>Surface of rotor</b>	Coated in black
<b>Material of blades</b>	PP plastic
<b>Material of guard grille</b>	Steel, coated in black plastic (RAL9005)
<b>Number of blades</b>	5
<b>Direction of air flow</b>	"V"
<b>Direction of rotation</b>	Counter-clockwise, seen on rotor
<b>Type of protection</b>	IP 44; Depending on installation and position as per EN 60034-5
<b>Insulation class</b>	"F"
<b>Humidity class</b>	F2-2
<b>Max. permissible ambient motor temp. (transp./ storage)</b>	+ 80 °C
<b>Min. permissible ambient motor temp. (transp./storage)</b>	- 40 °C
<b>Mounting position</b>	Shaft horizontal or rotor on bottom; rotor on top on request
<b>Condensate discharge holes</b>	Rotor-side
<b>Operation mode</b>	S1
<b>Motor bearing</b>	Ball bearing with anti-freezing grease
<b>Touch current acc. IEC 60990 (measuring network Fig. 4, TN system)</b>	< 0.75 mA
<b>Motor protection</b>	Thermal overload protector (TOP) brought out
<b>Cable exit</b>	Variable
<b>Protection class</b>	I (if protective earth is connected by customer)
<b>Product conforming to standard</b>	EN 60335-1; CE

Product drawing

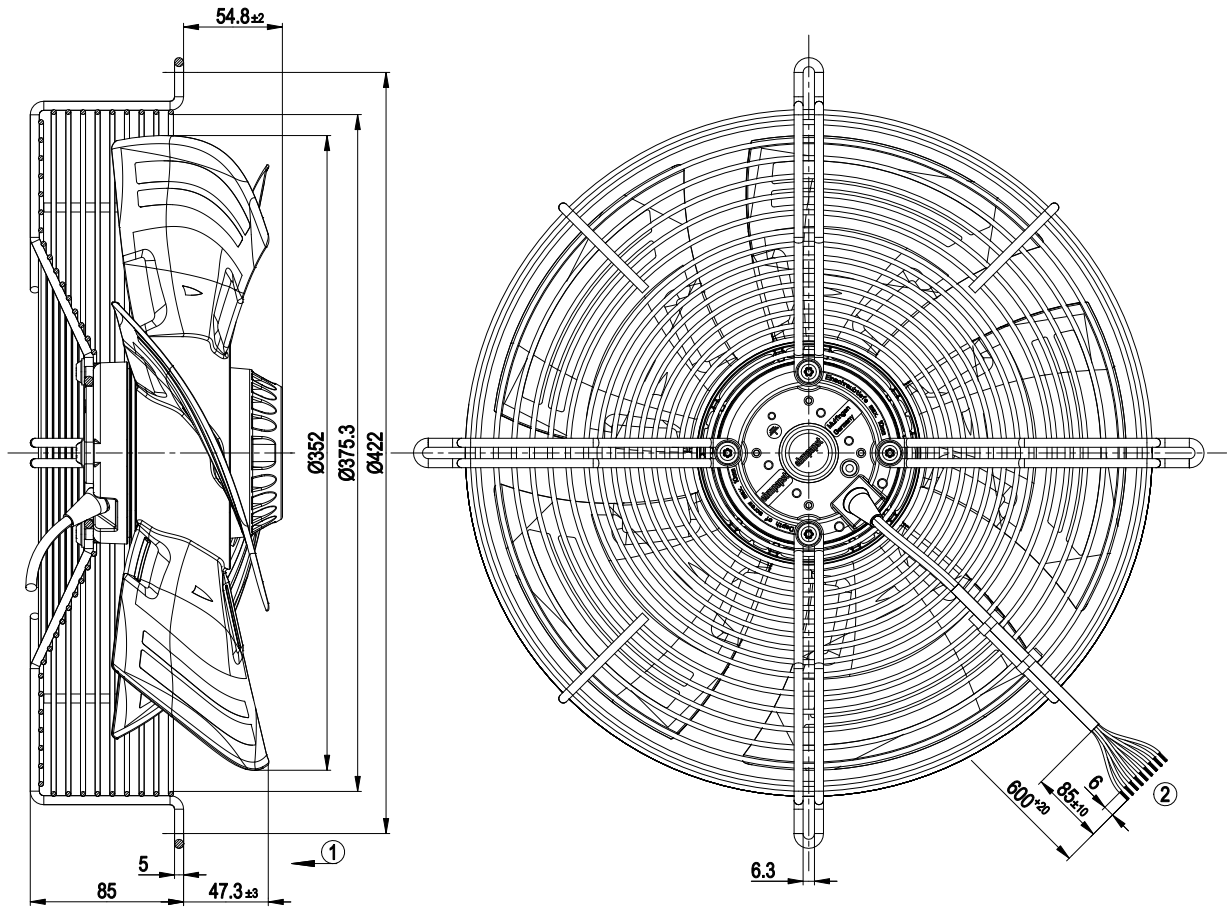

	Terminal box is included separately
1	Direction of air flow "V"
2	Connection line silicone 9G 0.5 mm <sup>2</sup> , 9x brass lead tips crimped



## Connection screen

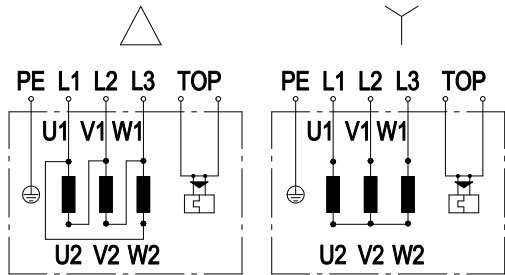

Δ	Delta connection	Y	Star connection	L1	black
L2	blue	L3	brown	U1	black
V1	blue	W1	brown	U2	green
V2	white	W2	yellow	TOP	2xgrey
PE	green/yellow				

## Charts: Air flow 50 Hz

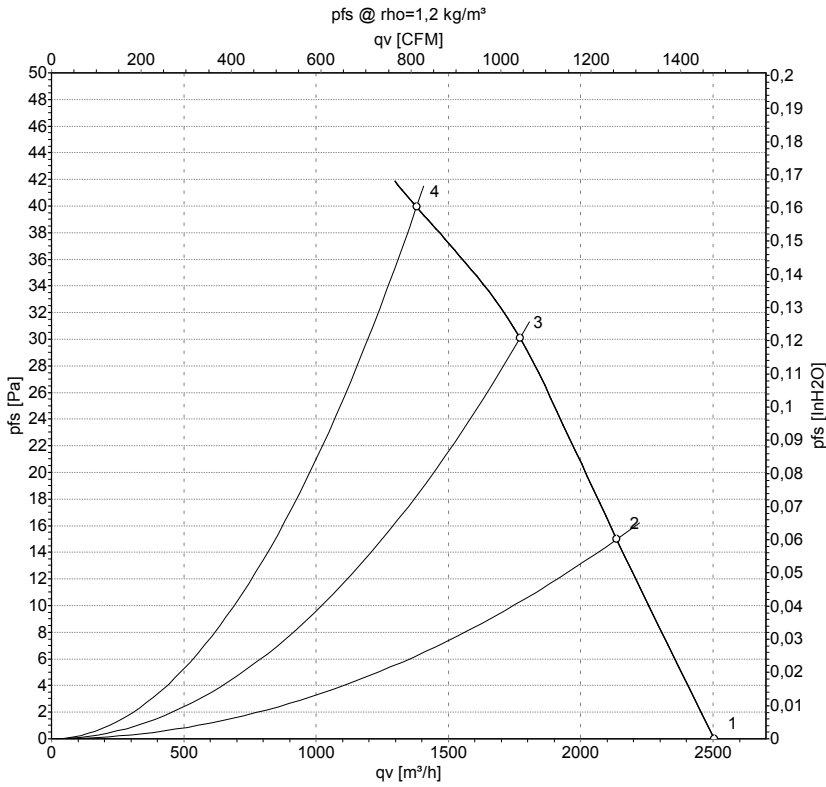

Measurement: LU-140571

Air performance measured as per ISO 5801 Installation category A. For detailed information on the measuring set-up, please contact ebm-papst. Suction-side noise levels: LwA measured as per ISO 13347 / LpA measured with 1m distance to fan axis. The values given are valid under the measuring conditions mentioned above and may vary according to the actual installation situation. With any deviation from the standard set-up, the specific values have to be checked and reviewed with the unit installed.

## Measured values

	Conn.	U	f	n	P <sub>e</sub>	I	qv	p <sub>fs</sub>
		V	Hz	min <sup>-1</sup>	W	A	m³/h	Pa
1	Y	400	50	1080	80	0.13	2505	0
2	Y	400	50	1025	85	0.14	2135	15
3	Y	400	50	980	89	0.15	1770	30
4	Y	400	50	930	95	0.16	1380	40

Conn. = Connection · U = Supply voltage · f = Frequency · n = Speed · P<sub>e</sub> = Power input · I = Current draw · qv = Air flow · p<sub>fs</sub> = Pressure increase



## Charts: Air flow 60 Hz

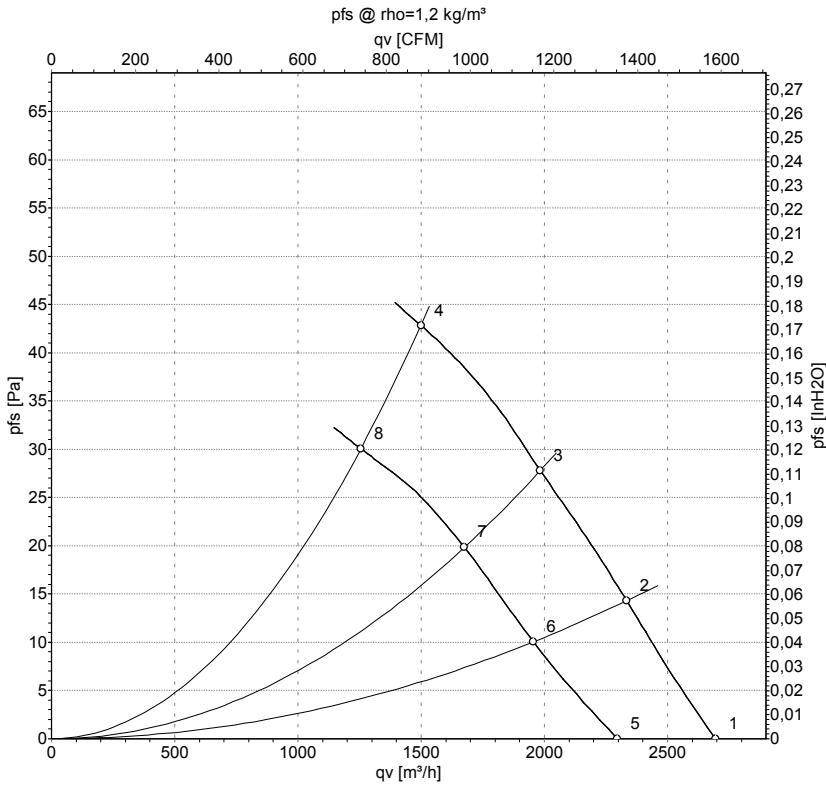

Measurement: LU-140577  
Measurement: LU-140575

Air performance measured as per ISO 5801 Installation category A. For detailed information on the measuring set-up, please contact ebm-papst. Suction-side noise levels: LwA measured as per ISO 13347 / LpA measured with 1m distance to fan axis. The values given are valid under the measuring conditions mentioned above and may vary according to the actual installation situation. With any deviation from the standard set-up, the specific values have to be checked and reviewed with the unit installed.

## Measured values

	Conn.	U	f	n	P <sub>e</sub>	I	qv	p <sub>fs</sub>
		V	Hz	min <sup>-1</sup>	W	A	m <sup>3</sup> /h	Pa
1	Y	480	60	1160	119	0.16	2695	0
2	Y	480	60	1100	124	0.17	2335	14
3	Y	480	60	1045	128	0.17	1985	28
4	Y	480	60	990	135	0.18	1500	42
5	Y	400	60	985	94	0.16	2295	0
6	Y	400	60	925	96	0.16	1955	10
7	Y	400	60	880	98	0.16	1675	20
8	Y	400	60	830	100	0.17	1255	30

Conn. = Connection · U = Supply voltage · f = Frequency · n = Speed · P<sub>e</sub> = Power input · I = Current draw · qv = Air flow · p<sub>fs</sub> = Pressure increase



## Данный компонент на территории Российской Федерации

### Вы можете приобрести в компании MosChip.

Для оперативного оформления запроса Вам необходимо перейти по данной ссылке:

<http://moschip.ru/get-element>

Вы можете разместить у нас заказ для любого Вашего проекта, будь то серийное производство или разработка единичного прибора.

В нашем ассортименте представлены ведущие мировые производители активных и пассивных электронных компонентов.

Нашей специализацией является поставка электронной компонентной базы двойного назначения, продукции таких производителей как XILINX, Intel (ex.ALTERA), Vicor, Microchip, Texas Instruments, Analog Devices, Mini-Circuits, Amphenol, Glenair.

Сотрудничество с глобальными дистрибьюторами электронных компонентов, предоставляет возможность заказывать и получать с международных складов практически любой перечень компонентов в оптимальные для Вас сроки.

На всех этапах разработки и производства наши партнеры могут получить квалифицированную поддержку опытных инженеров.

Система менеджмента качества компании отвечает требованиям в соответствии с ГОСТ Р ИСО 9001, ГОСТ РВ 0015-002 и ЭС РД 009

### Офис по работе с юридическими лицами:

105318, г.Москва, ул.Щербаковская д.3, офис 1107, 1118, ДЦ «Щербаковский»

Телефон: +7 495 668-12-70 (многоканальный)

Факс: +7 495 668-12-70 (доб.304)

E-mail: [info@moschip.ru](mailto:info@moschip.ru)

Skype отдела продаж:

moschip.ru

moschip.ru\_4

moschip.ru\_6

moschip.ru\_9