

AFBR-1624Z/1629Z and AFBR-2624Z/2529Z

DC, 50 MBd Versatile Link Fiber Optic Transmitter and Receiver for 1 mm POF and 200 μ m PCS



Data Sheet



Description

The AFBR-1624Z/1629Z transmitter utilizes a 650 nm LED source with integrated optics and driver IC for efficient coupling into 1 mm Plastic Optical Fiber (POF). The AFBR-2624Z/2529Z receiver consists of an IC with an integrated photodiode to produce a logic compatible output. The transmitter input and receiver output are compatible with TTL logic families. The pair operates any type of signal from DC up to 50 MBd at distances up to 50 m with 1 mm POF, up to 200 m at 10 MBd and 120 m at 50 MBd with 200 μ m Plastic-Clad Silica (PCS), respectively.

The transmitter is a 3-pin and the receiver is a 4-pin device, packed in Versatile Link housing. Versatile Link components can be interlocked (N-plexed together) to minimize space and to provide dual connections with the duplex connectors. Various simplex and duplex connectors, as well as POF cables are available for Versatile Link components. For details, contact Avago Technologies or visit our company website at www.avagotech.com

AFBR-xx24Z are delivering non inverted output signals while AFBR-xx29Z deliver inverted output signals.

Features

- RoHS-compliant
- Data transmission at signal rates from DC up to 50 MBd
- Transmitter: integrated 650 nm LED and driver IC with TTL input logic
- Receiver: integrated PIN diode and digitalizing IC with TTL output logic
- Up to 50 m distance with 1 mm Plastic Optical Fiber (POF) over operating temperature range
- Up to 200 m (10 MBd) distance and 120 m (50 MBd) distance with 200 μ m Plastic-Clad Silica (PCS) over operating temperature range
- Operating temperature range of -40 $^{\circ}$ C to +85 $^{\circ}$ C
- Compatible with Avago's Versatile Link family of connectors, for easy termination of fiber

Applications

Optical Transmitter and Receiver for 50 MBd systems and below:

- Industrial control and factory automation
- Extension of RS-232 and RS-485
- High voltage isolation
- Elimination of ground loops
- Reduces voltage transient susceptibility

Package and Handling Information

The Versatile Link package is made of a flame retardant VALOX® UL 94 V-0 material (UL file # E121562) and uses the same pad layout as a standard, eight pin dual-in-line package. These Versatile Link packages are stackable and are enclosed to provide a dust resistant seal. Snap action simplex, simplex latching, duplex, and duplex latching connectors are offered with simplex or duplex cables.

Package Housing Color

Versatile Link components and simplex connectors are color coded to eliminate confusion when making connections. Receivers are black and transmitters are grey.

Handling

Versatile Link components are auto-insertable. When wave soldering is performed with Versatile Link components, the optical port plug should be left in to prevent contamination of the port. Do not use reflow solder processes (i.e., infrared reflow or vapor-phase reflow). Non-halogenated water soluble fluxes (i.e., 0% chloride), not rosin based fluxes, are recommended for use with Versatile Link components.

Versatile Link components are moisture sensitive devices and are shipped in a moisture sealed bag. If the components are exposed to air for an extended period of time, they may require a baking step before the soldering process. Refer to the special labeling on the shipping tube for details.

Interlocked (Stacked) Assemblies (refer to Figure 1)

Horizontal packages may be stacked by placing units with pins facing upward. Initially engage the inter-locking mechanism by sliding the L bracket body from above into the L slot body of the lower package. Use a straight edge, such as a ruler, to bring all stacked units into uniform alignment. This technique prevents potential harm that could occur to fingers and hands of assemblers from the package pins. Stacked horizontal packages can be disengaged if necessary. Repeated stacking and unstacking causes no damage to individual units.

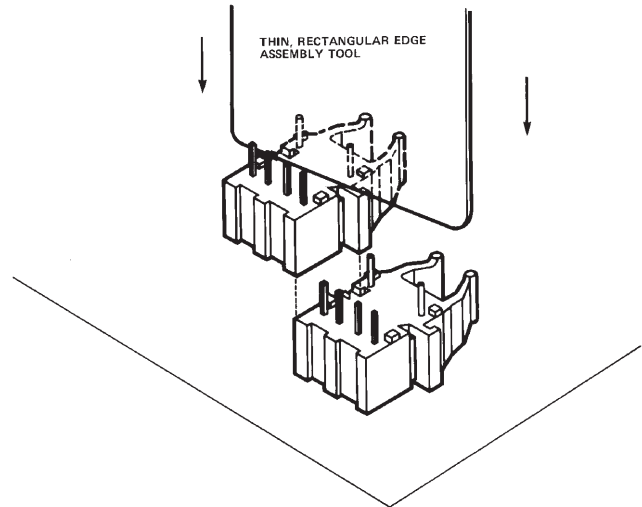
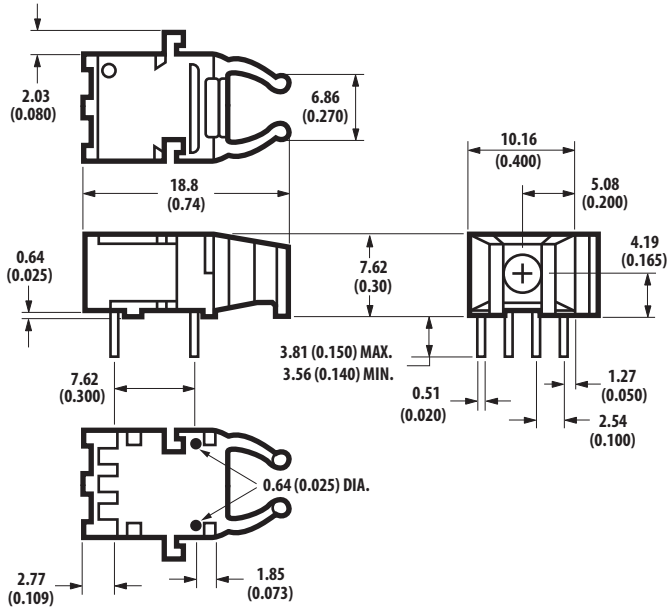
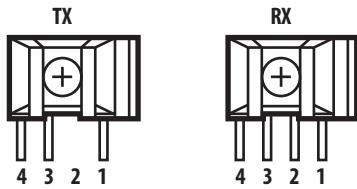
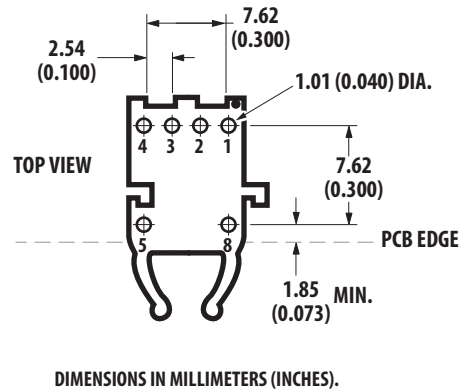

Figure 1. Interlocked (stacked) horizontal packages

Mechanical Dimensions



Printed Circuit Board Layout Dimension



Pin Description Transmitter

Fiber port facing front, pins downward, 1 = Rightmost pin to 4 = Leftmost pin

Pin	Name	Function/Description	Notes
1	V _{CCT}	Transmitter Power 3.3 V ± 5% or 5 V ± 5%	
2	No Pin	No physical pin is available	
3	V _{EET}	Transmitter Ground	
4	Data In	Transmitter Data Input	1, 2
5	NC	Not Connected, physical pin is available, recommended to Ground	3
8	NC	Not Connected, physical pin is available, recommended to Ground	3

Pin Description Receiver

Fiber port facing front, pins downward, 1 = Rightmost pin to 4 = Leftmost pin

Pin	Name	Function/Description	Notes
1	Data Out	Receiver Data Output	2
2	V _{EER}	Receiver Ground	
3	V _{CCR}	Receiver Power 3.3 V ± 5% or 5 V ± 5%	
4	NC	Not Connected, physical pin is available, recommended to Ground	4
5	NC	Not Connected, physical pin is available, recommended to Ground	3, 4
8	NC	Not Connected, physical pin is available, recommended to Ground	3, 4

Regulatory Compliance

Feature	Test Method	Performance
Electrostatic Discharge (ESD) to the Electrical Pins Human Body Model	MIL-STD-883 Method 3015	Min \pm 2000 V
Eye Safety	IEC 60825-1, 2, Class 1	

Specified Link Performance, $T_A = -40^\circ\text{C}$ to $+85^\circ\text{C}$, 50 MBd

Parameter	Min	Max	Unit	Condition	Note
Link Distance with Standard POF cable	0.1	50	meters	-40°C to $+85^\circ\text{C}$	5
Link distance with 200 μm PCS (10 MBd)	0.1	200	meters	-40°C to $+85^\circ\text{C}$	6
Link distance with 200 μm PCS (50 MBd)	0.1	120	meters	-40°C to $+85^\circ\text{C}$	6

Notes:

- Logic 1 input will turn the light on and the logic 0 will turn the light off for AFBR-1624Z. Logic 1 input will turn the light off and the logic 0 will turn the light on for AFBR-1629Z.
- TTL compatible data input and output.
- Pin 5 and 8 are for mounting and retaining purposes, and should be electrically connected to PCB ground.
- It is recommended to connect this pin to ground.
- POF is HFBR-R/EXXXXX plastic (1 mm) optical fiber. Worst-case attenuation used (0.27 dB/m for standard loss POF cable from -40°C to $+85^\circ\text{C}$ at 660 nm).
- PCS, worst-case attenuation (12 dB/km from -40°C to $+85^\circ\text{C}$ at 650 nm).

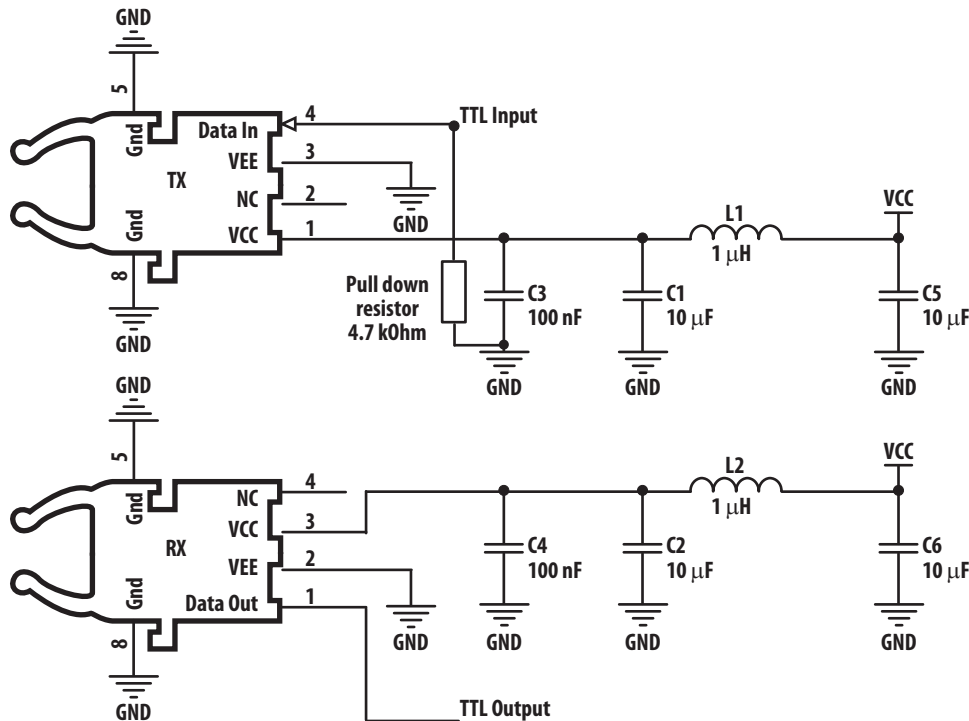

Figure 2. Recommended Transmitter and Receiver Application Circuit

Absolute Maximum Ratings

Parameter	Symbol	Min	Typical	Max	Unit	Notes
Storage Temperature	T _s	-40		85	°C	7
Ambient Temperature	T _c	-40		85	°C	7
Relative Humidity	RH	0		85	%	7
Supply Voltage	V _{CCT} /V _{CCR}	-0.5		6	V	7
Data Input Voltage	V _{IN}	-0.5		V _{CC} +0.5	V	7
Data Output Current	I _O			10	mA	7
Data Rate		DC		50	MBd	

Notes:

7. Absolute Maximum Ratings are those values beyond which damage to the device may occur if these limits are exceeded for other than a short period of time.

Recommended Operating Conditions

Parameter	Symbol	Min	Typical	Max	Unit	Notes
Ambient Temp	T _A	-40	25	85	°C	8
Supply Voltage	V _{CCT} /V _{CCR}	3.135	3.3	3.465	V	8
		4.75	5	5.25	V	8

Notes:

8. Recommended operating conditions are those values outside of which functional performance is not intended, device reliability is not implied, and damage to the device may occur over an extended period of time. See Reliability Data Sheet for specific reliability performance.

Process Compatibility

Parameter	Symbol	Min	Typical	Max	Unit	Notes
Solder Environment	T _{SOLD}			260	°C	9, 11, 12
	t _{SOLD}			10	sec	10, 11, 12

Notes:

9. Maximum temperature refers to peak temperature.
10. Maximum time refers to time spent at peak temperature.
11. Solder surface to be at least 1mm below lead frame stops.
12. Product is moisture sensitive level 3.

AFBR-1624Z/1629Z Transmitter

The AFBR-1624Z/1629Z transmitter incorporates a 650 nm LED and integrated driver IC in a light gray, nonconductive plastic Versatile Link housing. Its input data is compatible with TTL logic level. This transmitter can operate from DC to 50 MBd with any kind of data pattern using 1 mm plastic optical fiber (POF). Within the specified ranges AFBR-1624Z and AFBR-1629Z devices will support a BER < 10E-9.

Transmitter Electrical Characteristics

($T_A = -40\text{ }^\circ\text{C}$ to $+85\text{ }^\circ\text{C}$, $V_{CCT} = 3.3\text{ V} \pm 5\%$ or $5\text{ V} \pm 5\%$)

Parameter	Symbol	Min	Typical	Max	Unit	Notes
Supply Current (Optical Power ON)	I_{CCT}		21	31	mA	1
Input Voltage – Low	V_{IL}	-0.3		0.8	V	2
Input Voltage – High	V_{IH}	2.0		$V_{CC}+0.3$	V	2
Data Input Capacitance	C_{IN}			7	pF	
Data Input Resistance	R_{IN}	2			k Ω	
Propagation Delay	t_{TD}			30	ns	

Transmitter Optical Characteristics

($T_A = -40\text{ }^\circ\text{C}$ to $+85\text{ }^\circ\text{C}$, $V_{CCT} = 3.3\text{ V} \pm 5\%$ or $5\text{ V} \pm 5\%$)

Parameter	Symbol	Min	Typical	Max	Unit	Notes
Output Optical Power (peak), 1 mm POF	P_N	-5.5	-2	+2	dBm	3
Output Optical Power (peak), PCS (200 μm)	P_N	-16.5	-13	-9	dBm	
Output Optical Power (Average), OFF	P_S			-50	dBm	
Extinction Ratio	ER	10			dB	
Peak Wavelength	λ_c	630		685	nm	
Rise Time (20%–80%)	t_{RT}			5	ns	
Fall Time (20%–80%)	t_{FT}			5	ns	
Pulse Width Distortion	PWD	-3		+3	ns	4, 5
Pulse Width Distortion of first pulse	PWD	-5		+3	ns	5, 6

Notes:

1. For any type of data between DC and 50 Mbaud. Typical value 21 mA for PRBS-7 pattern at 25° C at 5 V and 50 Mbaud.
2. Standard TTL compatible input.
3. Measured after 1 meter 0.5 NA 1 mm POF or 200 μm PCS with polished connector end face.
4. Pulse width is measured at 50% threshold using a rising edge trigger tested with PRBS-7 pattern
5. Electrical input pulse width is determined at 1.5 V and dU/dt between 1 V and 2 V shall not be less than 1 V/ns.
6. The first pulse is shorter as the LED is completely discharged. This helps to mitigate the increase of pulse width of the first pulse of the Receiver

AFBR-2624Z/2529Z Receiver

The AFBR-2624Z/2529Z receiver consists of a digitalizing IC with integrated photodiode to produce an output level that is compatible with TTL logic. The integrated photodiode and the following amplifier uses a fully differential approach with an active and a passive area for an improved EMI performance. Within the specified ranges AFBR-2529Z and AFBR-2624Z devices will support a BER <10E-9.

Receiver Electrical Characteristics

($T_A = -40^\circ\text{C}$ to $+85^\circ\text{C}$, $V_{CC_T} = 3.3\text{V} \pm 5\%$ or $5\text{V} \pm 5\%$)

Parameter	Symbol	Min	Typical	Max	Unit	Notes
Supply Current	I_{CCR}		20	30	mA	
Data Output Voltage – Low	V_{OL}	-0.3		0.4	V	1
Data Output Voltage – High	V_{OH}	2.5		$V_{CC_T}+0.3$	V	1
Rise Time (10%–90%)	t_{RR}			5	ns	2, 3
Fall Time (10%–90%)	t_{FR}			5	ns	2, 3
Pulse Width Distortion	PWD	-4		+4	ns	6, 7, 8, 11
Pulse Width Distortion 1 st to 3 rd pulse	PWD_{init}	-5		+8	ns	8, 9, 11
Propagation Delay	t_{RD}			30	ns	

Receiver Optical Characteristics

($T_A = -40^\circ\text{C}$ to $+85^\circ\text{C}$, $V_{CC_T} = 3.3\text{V} \pm 5\%$ or $5\text{V} \pm 5\%$)

Parameter	Symbol	Min	Typical	Max	Unit	Notes
Input Optical Power (Peak), 1 mm POF	P_{IN}	-22		+2	dBm	
Input Optical Power Off-State, 1 mm POF	P_{IN_Off}	-40			dBm	10
Input Optical Power, PCS (200 μm)	P_{IN}	-25		-1	dBm	
Input Optical Power Off-State, PCS (200 μm)	P_{IN_Off}	-44			dBm	
Optical Spectrum Range	λ	630		685	nm	

Notes:

1. Standard TTL output.
2. Measured with $R_L = 50\text{ k}\Omega$ and $C_L = 15\text{ pF}$
3. Optical Power generated by a standard Avago Technologies Transmitter, with ideal alignment to the photodiode using a 1 mm POF (NA = 0.5).
6. Optical input of 50 MBd PRBS-7 pattern and 50% duty cycle.
7. Pulse width is measured at 50% threshold using a rising edge trigger and PRBS-7 pattern.
8. If data rate is below 1MBd the pulse width distortion would be equal to the pulse width distortion of the 1st to 3rd pulses for higher data rates.
9. The threshold of the 1st pulse of a data sequence is difficult to adjust and therefore the pulse width distortion up to the 3rd pulse is higher than for all other pulses (worst case for the 1st pulse). This strongly depends on the quality of the rising and falling edge of the optical input. The faster the edges the smaller the pulse width variation. Furthermore lower data rates would result in the same issue as all the pulse become 1st pulses.
10. Output low for AFBR-2624Z and Output high for AFBR-2529Z.
11. Because of optical pulse width spreading, the PWD limits have to be increased by $\pm 0.1\text{ ns}$ for each 10 m fiber length.

For product information and a complete list of distributors, please go to our web site: www.avagotech.com

Avago, Avago Technologies, and the A logo are trademarks of Avago Technologies in the United States and other countries.
Data subject to change. Copyright © 2005–2013 Avago Technologies. All rights reserved.
AV02-3407EN - Feb 19, 2013

Avago
TECHNOLOGIES

Данный компонент на территории Российской Федерации

Вы можете приобрести в компании MosChip.

Для оперативного оформления запроса Вам необходимо перейти по данной ссылке:

<http://moschip.ru/get-element>

Вы можете разместить у нас заказ для любого Вашего проекта, будь то серийное производство или разработка единичного прибора.

В нашем ассортименте представлены ведущие мировые производители активных и пассивных электронных компонентов.

Нашей специализацией является поставка электронной компонентной базы двойного назначения, продукции таких производителей как XILINX, Intel (ex.ALTERA), Vicor, Microchip, Texas Instruments, Analog Devices, Mini-Circuits, Amphenol, Glenair.

Сотрудничество с глобальными дистрибьюторами электронных компонентов, предоставляет возможность заказывать и получать с международных складов практически любой перечень компонентов в оптимальные для Вас сроки.

На всех этапах разработки и производства наши партнеры могут получить квалифицированную поддержку опытных инженеров.

Система менеджмента качества компании отвечает требованиям в соответствии с ГОСТ Р ИСО 9001, ГОСТ РВ 0015-002 и ЭС РД 009

Офис по работе с юридическими лицами:

105318, г.Москва, ул.Щербаковская д.3, офис 1107, 1118, ДЦ «Щербаковский»

Телефон: +7 495 668-12-70 (многоканальный)

Факс: +7 495 668-12-70 (доб.304)

E-mail: info@moschip.ru

Skype отдела продаж:

moschip.ru

moschip.ru_4

moschip.ru_6

moschip.ru_9