



PRODUCT OVERVIEW

The D1U54-D-1200-12-Hx4PC series are highly efficient 1200 watt, DC input front end modules with a 12V main output and a choice of 3.3V or 5V (20W) standby rails. The power module is able to current share with up to eight (8) other power modules of the same type operating in parallel or N+1 redundancy. The supplies may be hot plugged, and include integral isolation devices.

The power modules are fully protected from overload and overvoltage and are able to auto-recover from overtemperature faults. A Status LED is provided on the front panel and additional control and status reporting is provided by hardware logic signals and via a PMBus™ digital interface.

A low profile sub 1U height enclosure provides an excellent power density of >28W/in³ that is ideal for delivering reliable, efficient power to servers; workstations; storage systems and other 12V distributed power systems, including direct operation from intermediate bus converters.

FEATURES

- 1200W output power (no derating across the full DC input voltage range)
- 1.57"(1U) x 12.65" x 2.15"
- 92% efficiency
- 12VDC Main output
- 3.3VSB or 5VSB output (20W)
- >28W/in³ power density
- N+1 Redundancy Capable; hot plug/swap (up to 8 modules in parallel)
- Active current sharing on 12V main output; integral MOSFET ORING
- Over-Voltage, Over-Current; Over-Temperature Protection
- Internal variable speed cooling fans
- PMBus™ Power Management Bus
- RoHS Compliant

ORDERING GUIDE

Part Number	Power Output	Main Output	Standby Output	Airflow
D1U54-D-1200-12-HC4PC	1200W	12V	3.3V	Back to Front
D1U54-D-1200-12-HA4PC			5V	
D1U54-D-1200-12-HC3PC			3.3V	Front to Back
D1U54-D-1200-12-HA3PC			5V	

INPUT CHARACTERISTICS

Parameter	Conditions	Min	Typ	Max	Units
DC Input Voltage Operating Range		-40	-48/-60	-72	
Turn-on Input Voltage	Ramp Up	-39.5	-40	-40.5	Vdc
Turn-off Input Voltage	Ramp Down	-35.5	-36	-36.5	
Maximum Current @ VIN = -48Vdc	1200W			40	Adc
DC Input Inrush Peak Current	Cold start between 0 to 200ms	-40		50	Apk
		-72		100	
Efficiency (-48Vdc)	20% FL		90		%
	50% FL		92		
	100% FL		90		
Reverse polarity protection	Reversed input cables; no internal/external fuse failure	+40		+72	Vdc

OUTPUT VOLTAGE CHARACTERISTICS

Output Voltage	Parameter	Conditions	Min.	Typical	Max.	Units
Main 12V	Voltage Set Point			12		Vdc
	Line & Load Regulation	Combined regulation	11.6		12.4	
	Ripple & Noise ¹	20MHz Bandwidth			120	mV P-P
	Output Current	-40Vdc to -72Vdc DC input	0		100A	A
	Load Capacitance				30,000	µF
3.3VSB	Voltage Set Point			3.3		Vdc
	Line & Load Regulation	Combined regulation	3.14		3.46	
	Ripple Voltage & Noise ¹	20MHz Bandwidth			120	mV P-P
	Output Current		0		6	A
	Load Capacitance				10,000	µF
5VSB	Voltage Set Point			5.0		Vdc
	Line & Load Regulation		4.76		5.24	
	Ripple Voltage & Noise ¹	20MHz Bandwidth			120	mV P-P
	Output Current		0		4	A
	Load Capacitance				10,000	µF

¹ Ripple and noise are measurements are to be performed with a parallel combination of a 0.1µF ceramic capacitor and 10µF tantalum capacitance on each of the power module output measurement nodes. A short coaxial cable from measurement point to 'scope shall be used



Available now at
www.murata-ps.com/en/3d/acdc.html



OUTPUT CHARACTERISTICS

Parameter	Conditions	Min.	Typ.	Max.	Units
Remote Sense (Main Output)	Overall compensation at full load; +VE & -VE connections			120	mV
Output Rise (Monotonic)	10% to 95% rise time		No positive voltage excursion		
Startup Time	DC Ramp Up			3	s
	PS_ON activation		200		ms
Transient Response	12V, 50-100% or 100-50% step load; 1A/μs slew rate		±600		mV
	3.3/5VSB 50-100% or 100-50% step load 1A/μs slew rate		±165/250		
Current Sharing Accuracy (between sharing modules; up to 8 in parallel)	At 100% load			±10	%
Hot Swap Transients				5	%
Hold Up Time ¹	FL (Full Load); 48VDC nominal input prior to hold up	1			ms

ENVIRONMENTAL CHARACTERISTICS

Parameter	Conditions	Min.	Typ.	Max.	Units
Storage Temperature Range	Non-Condensing	-40		70	°C
Operating Temperature Range	1200W Output Power	0		55	
Operating Humidity	Non-Condensing	5		90	%
Storage Humidity		5		95	
Altitude (no derating at 40°C)		3000			m
Shock	Non-Operating			30	G
Sinusoidal Vibration	Operational, 0.5G; 5-500Hz				
MTBF	Telcordia SR-332 M1C1 @ 40°C	452			K Hours
Safety Approvals (Standards) – Pending Submission	CSA/UL C22.2 No.60950-1-07, 2nd Ed. IEC 60950-1:2005, (2nd Edition) with Am. 1:2009 EN 60950-1:2006 + A11:2009 + A1:2010 CE Marking per LVD DIRECTIVE 2006/95/EC				
Input Fusing	Internal 60A/170VDC fast blow fuse on the DC line input (TBC)				
Weight				3.15/1.43	Lbs/kg

PROTECTION CHARACTERISTICS

Output Voltage	Parameter	Conditions	Min.	Typ.	Max.	Units
N/A	Over-Temperature	Air inlet temperature; Auto re-start	60	65	70	°C
12V (Main)	Over-Voltage	Latching; toggle PS_ON or recycle DC input to reset	13		14	V
	Over-Current	For slow overload events a constant current will be sustained for 1sec followed by a latch off that will auto reset in 5secs. For hard (short circuit) events the output will shut down within 50ms and auto restart within 200ms. This cycle will be repeated ten times at which point the output will permanently latch off. The power module will require to be reset by recycling the incoming DC source or “toggling” PS_ON.	115		135	A
	Over-Voltage	Latching; toggle PS_ON or recycle DC input to reset	3.6		4.0	V
3.3VSB	Over-Current	Shutdown followed by auto-recovery	6.5		8.5	A
	Over-Voltage	Latching; toggle PS_ON or recycle DC input to reset	5.4		6.0	V
5VSB	Over-Current	Shutdown followed by auto-recovery	4.5		5.5	A

ISOLATION CHARACTERISTICS

Parameter	Conditions	Min.	Typ.	Max.	Units
Insulation Safety Rating/Test Voltage	Input to Output - Basic	1000			Vrms
Isolation	Output to Chassis (Ground)	500			Vdc

¹Assumes deployment within systems utilizing dual redundant “A” and “B” DC input feeds

STATUS INDICATORS

Conditions	GREEN (Power) LED Status	AMBER (Fault) LED Status
No incoming DC supply present; power module completely off.	LED not illuminated	LED not illuminated
Standby Rail ON; Main Output OFF; DC input present & correct	Blinking	LED not illuminated
Standby Rail ON; Main Output ON	Solid Green	
Main Output overcurrent; undervoltage, overvoltage warning	LED not illuminated	Solid Amber
FAN_FAULT; overtemperature; standby rail overcurrent, Main Output overcurrent or overvoltage	LED not illuminated	Solid Amber
Power Module Warning Event	LED not illuminated	Blinking

EMISSIONS AND IMMUNITY

Characteristic	Standard	Compliance
Conducted Emissions	FCC 47 CFR Part 15 CSIPR 22/EN55022	Class A with 6dB margin
ESD Immunity	IEC/EN 61000-4-2;	Level 4; Criteria A
Radiated Field Immunity	IEC/EN 61000-4-3	Level 3; Criteria B
Electrical Fast Transients/Burst Immunity	IEC/EN 61000-4-4	Level 3; Criteria A
Surge Immunity	IEC/EN 61000-4-5	Level 3; Criteria A
RF Conducted Immunity	IEC/EN 61000-4-6	Level 3; Criteria A
Magnetic Field Immunity	IEC/EN 61000-4-8	3A/m; Criteria B
Voltage Dips & Interruptions	NEBS GR-1089-CORE Issue	Relevant sections and compliance levels TBD

OUTPUT CONNECTOR AND SIGNAL INTERFACE

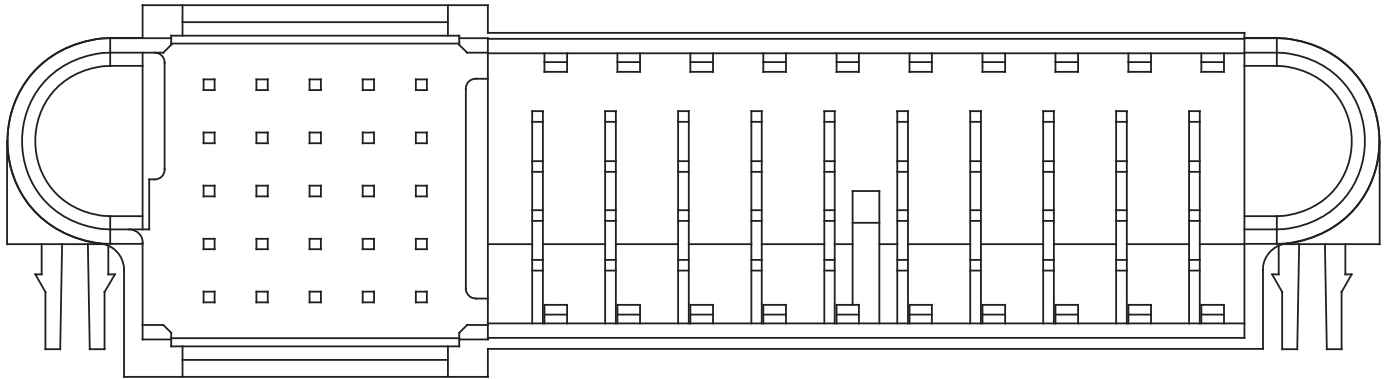

PART NUMBER	ROWS	SIGNALS					POWERS									
		1	2	3	4	5	1	2	3	4	5	6	7	8	9	10
1926734-2	A B C D E	<i>2</i>	<i>2</i>	<i>2</i>	<i>2</i>	<i>1</i>	<i>2</i>	<i>2</i>	<i>2</i>	<i>2</i>	<i>2</i>	<i>2</i>	<i>2</i>	<i>2</i>	<i>2</i>	<i>2</i>
25S X 10P																

NB: With respect to signals columns 5, the italic "1" refers to the shortest level signal pin/power blade; the italic "2" is the "longest" signal pin. The "shortest" pins are the "last to make, first to break" in the mating sequence.

PIN ASSIGNMENTS: D1U54-D-1200-12-HxxPC

TE Connectivity 1926734-2 (Power Supply)

Pin	Function	Description
6, 7, 8, 9, 10	V1 (+12VOUT)	+12V Main Output
1, 2, 3, 4, 5	+12V RTN/PGND	+12V Main Output Return
A1	+VSB	Standby Output
B1	+VSB	Standby Output
C1	+VSB	Standby Output
D1	+VSB	Standby Output
E1	+VSB	Standby Output
A2	+VSB_Return	Standby Output Return
B2	+VSB_Return	Standby Output Return
C2	Unused	No End User Connection
D2	Unused	No End User Connection
E2	Unused	No End User Connection
A3	APS	I2C Address Protocol Selection (Select by appropriate pull down resistor)
B3	Unused	No End User Connection
C3	SDA	I2C Serial Data Line
D3	V1_SENSE_R	Remote Sense Return (-VE)
E3	V1_SENSE	Remote Sense (+VE)
A4	SCL	I2C Serial Clock Line
B4	PS_ON_L	Remote On/Off (Enable/Disable)
C4	SMB_ALERT	Alert signal to host system
D4	Unused	No End User Connection
E4	DC_OK	DC Input Source Present & "OK"
A5	PS_KILL	Power Supply "kill"; short pin
B5	ISHARE	Current Share bus; short pin
C5	PW_OK	Power "OK"; short pin
D5	Unused	No End User Connection
E5	PRESENT_L	Power Module Present; short pin

ALTERNATIVE PIN ASSIGNMENTS: D1U54-D-1200-12-HxxC

TE Connectivity 1926734-4 (Power Supply)

Pin	Function	Description
6, 7, 8, 9, 10	V1 (+12VOUT)	+12V Main Output
1, 2, 3, 4, 5	+12V RTN/PGND	+12V Main Output Return
A1	+VSB	Standby Output
B1	+VSB	Standby Output
C1	+VSB	Standby Output
D1	+VSB	Standby Output
E1	+VSB	Standby Output
A2	+VSB_Return	Standby Output Return
B2	+VSB_Return	Standby Output Return
C2	Unused	No End User Connection
D2	Unused	No End User Connection
E2	Unused	No End User Connection
A3	PS_KILL	Power Supply "kill"; short pin
B3	Unused	No End User Connection
C3	SDA	I ² C Serial Data Line
D3	V1_SENSE_R	Remote Sense Return (-VE)
E3	V1_SENSE	Remote Sense (+VE)
A4	SCL	I ² C Serial Clock Line
B4	PS_ON_L	Remote On/Off (Enable/Disable)
C4	SMB_ALERT	Alert signal to host system
D4	ISHARE	Current Share bus; short pin
E4	DC_OK	DC Input Source Present & "OK"
A5	A0	I ² C LSB Address Line
B5	Unused	No End User Connection
C5	PW_OK	Power "OK"; short pin
D5	A1	I ² C Address Line
E5	PRESENT_L	Power Module Present; short pin

Consult Murata Sales for availability of alternative "HxxC" model variants.

MATING CONNECTOR (OUTPUT & SIGNALS)

Supplier	Press Fit, Straight	Press Fit, Right Angle	Solder Straight	Solder Right Angle
TE Connectivity (Tyco)	---	---	---	2-1926739-5 2-1926733-5 (Legacy Now Obsolete)

DC INPUT TERMINAL BLOCK

Dinkle Enterprise	2 Way Terminal Block; 40A rating; +VE & -VE DC Input cable connections	DT-7C-B14W-02
-------------------	--	---------------

WIRING DIAGRAM FOR OUTPUT

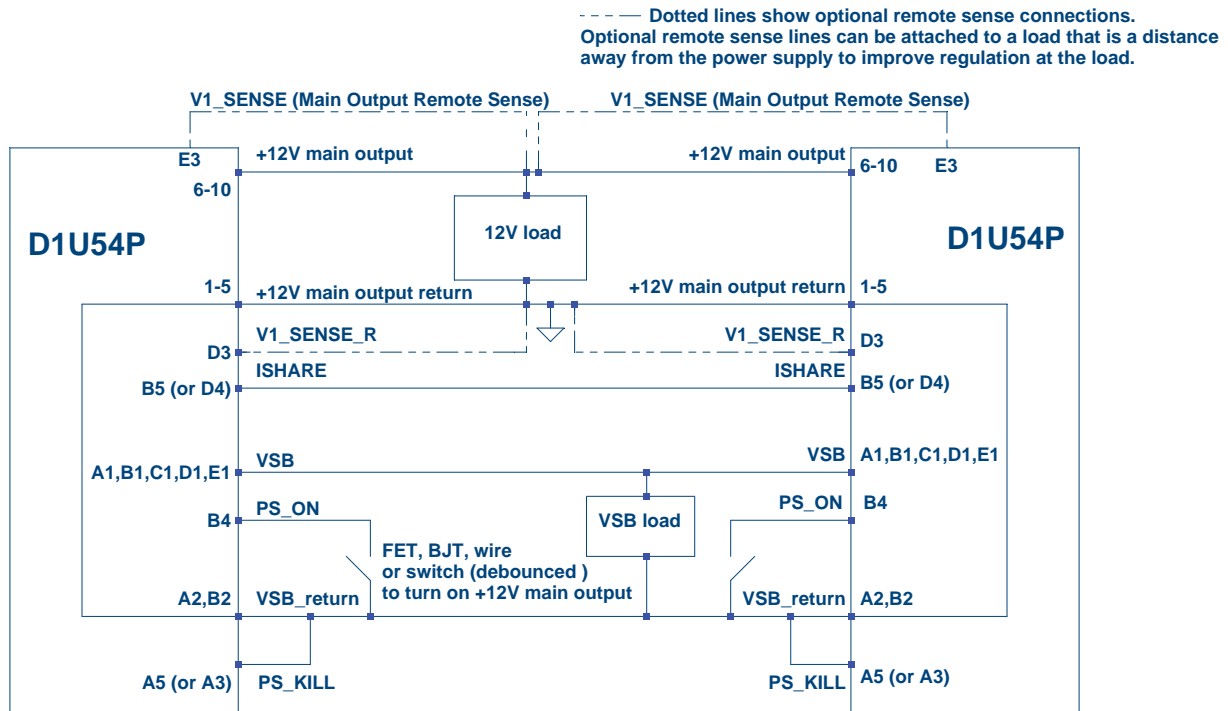

CURRENT SHARING NOTES

1. Main 12VDC Output: Analogue active share bus. The ISHARE bus (Pin B5 or D4) must be connected on all sharing modules. It is not required that the SENSE signals are connected to the remote load for current share to operate correctly.
2. Up to eight (8) power modules can be connected in parallel (non-redundant) or N+1 configuration. The current share bus is analogue bi-directional (can source or sink current from the ISHARE bus).
The voltage of the bus would measure 8VDC for a single power module at 100% load; for two (2) modules sharing a common load the ISHARE bus voltage would be 4V for a perfect 50/50 current share scenario.
3. The VSB (Standby Output) output of the power module can also be connected in parallel; internal output isolation devices are provided however the combined available power is limited to that available from a single power module (3.3V or 5V; 20W) irrespective of the number of modules connected in parallel.

MECHANICAL DIMENSIONS

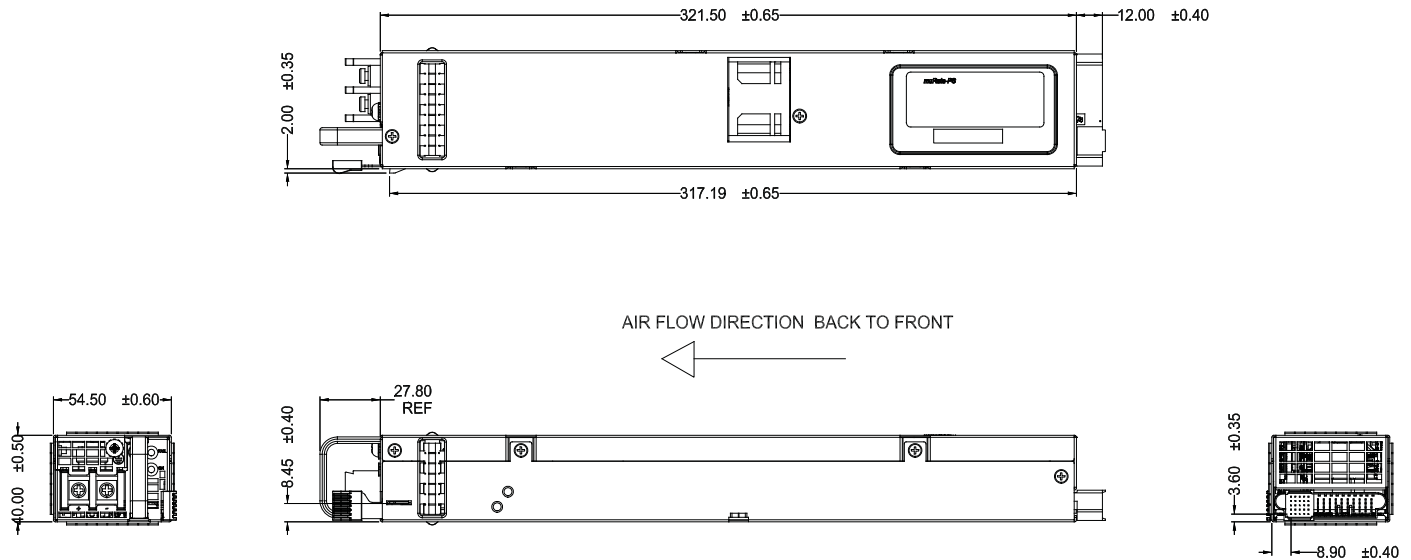

Notes

1. Dimensions: 1.57" x 12.66" x 2.15" (40.0 x 321.5mm x 54.5mm)
2. Safety earth/ground connection via separate dedicated M4 pan head screw connection (located above terminal block)

OPTIONAL ACCESSORIES

Description	Part Number
D1U54-12 Output Interface Connector Card	D1U54P-12-CONC

APPLICATION NOTES

Document Number	Description	Link
ACAN-44	D1U54P-12-CONC Output Interface Connector Card	www.murata-ps.com/data/apnotes/acan-44.pdf
ACAN-58	D1U54-D-12 Communications Protocol	

Murata Power Solutions, Inc.
 11 Cabot Boulevard, Mansfield, MA 02048-1151 U.S.A.
 ISO 9001 and 14001 REGISTERED



This product is subject to the following operating requirements and the Life and Safety Critical Application Sales Policy:
 Refer to: <http://www.murata-ps.com/requirements/>

Murata Power Solutions, Inc. makes no representation that the use of its products in the circuits described herein, or the use of other technical information contained herein, will not infringe upon existing or future patent rights. The descriptions contained herein do not imply the granting of licenses to make, use, or sell equipment constructed in accordance therewith. Specifications are subject to change without notice. © 2015 Murata Power Solutions, Inc.

Данный компонент на территории Российской Федерации

Вы можете приобрести в компании MosChip.

Для оперативного оформления запроса Вам необходимо перейти по данной ссылке:

<http://moschip.ru/get-element>

Вы можете разместить у нас заказ для любого Вашего проекта, будь то серийное производство или разработка единичного прибора.

В нашем ассортименте представлены ведущие мировые производители активных и пассивных электронных компонентов.

Нашей специализацией является поставка электронной компонентной базы двойного назначения, продукции таких производителей как XILINX, Intel (ex.ALTERA), Vicor, Microchip, Texas Instruments, Analog Devices, Mini-Circuits, Amphenol, Glenair.

Сотрудничество с глобальными дистрибьюторами электронных компонентов, предоставляет возможность заказывать и получать с международных складов практически любой перечень компонентов в оптимальные для Вас сроки.

На всех этапах разработки и производства наши партнеры могут получить квалифицированную поддержку опытных инженеров.

Система менеджмента качества компании отвечает требованиям в соответствии с ГОСТ Р ИСО 9001, ГОСТ РВ 0015-002 и ЭС РД 009

Офис по работе с юридическими лицами:

105318, г.Москва, ул.Щербаковская д.3, офис 1107, 1118, ДЦ «Щербаковский»

Телефон: +7 495 668-12-70 (многоканальный)

Факс: +7 495 668-12-70 (доб.304)

E-mail: info@moschip.ru

Skype отдела продаж:

moschip.ru

moschip.ru_4

moschip.ru_6

moschip.ru_9