

MASW6010G



GaAs SPDT Switch
DC - 6.0 GHz

Rev. V6

Features

- Low Insertion Loss: 0.5 dB Typical @ 4 GHz
- Fast Switching Speed: 4 ns Typical
- Ultra Low DC Power Consumption

Description

M/A-COM Technology's MASW6010G is an SPDT GaAs MESFET MMIC. This part combines small size, low insertion loss and power consumption with high isolation. Ideal for many applications and module use. It will function well for designs below 6 GHz.

This die includes full passivation for performance and reliability.

Pad Layout

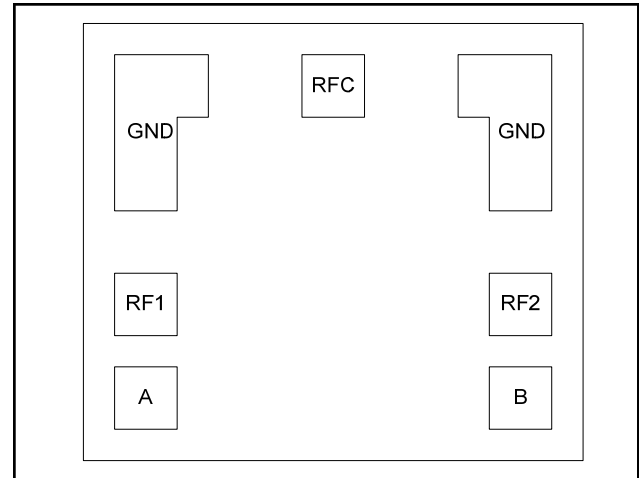

Ordering Information¹

Part Number	Package
MASW6010G	Die

1. Die quantity varies.

Bond Pad Dimensions

Bond Pad	Dimension Inches (mm)
RFC	0.004 x 0.004 (0.100 x 0.100)
RF2, RF3	0.004 x 0.004 (0.100 x 0.100)
A, B	0.004 x 0.004 (0.100 x 0.100)
GND1, GND2	0.012 x 0.004 (0.300 x 0.100)
DIE Size	0.031 x 0.031 x 0.010 (0.80 x 0.80 x 0.25)

Absolute Maximum Ratings²

Parameter	Absolute Maximum
Control Voltage (A/B)	-8.5 VDC
Input RF Power	+34 dBm (500 MHz - 6 GHz)
Operating Temperature	+175°C
Storage Temperature	-65°C to +175°C

2. Exceeding any one or combination of these limits may cause permanent damage to this device.

Schematic

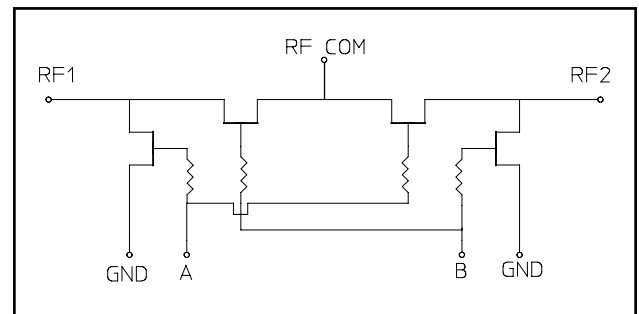

Electrical Specifications ^{3,4}: $T_A = 25^\circ\text{C}$, $Z_0 = 50 \Omega$

Parameter	Test Conditions	Units	Min.	Typ.	Max.
Insertion Loss	DC - 1.0 GHz	dB	—	—	0.6
	DC - 2.0 GHz		—	—	0.8
	DC - 6.0 GHz		—	—	1.4
Isolation	DC - 1.0 GHz	dB	45	—	—
	DC - 2.0 GHz		38	—	—
	DC - 6.0 GHz		22	—	—
VSWR	DC - 1.0 GHz	Ratio	—	—	1.1:1
	DC - 2.0 GHz		—	—	1.2:1
	DC - 6.0 GHz		—	—	1.9:1
Trise, Tfall	10% to 90% RF and 90% to 10% RF	ns	—	2	—
Ton, Toff	50% control to 90% RF, and 50% control to 10% RF	ns	—	4	—
Transients	In-Band	mV	—	10	—
Input P1dB	Above 500 MHz, 0 to -5 V	dBm	—	+27	—
	100 MHz, 0 to -5 V		—	+21	—
	Above 500 MHz, 0 to -8 V		—	+33	—
	100 MHz, 0 to -8 V		—	+26	—
IP2	Two Tone, +5 dBm/Tone, 5 MHz Spacing Above 500 MHz	dBm	—	+68	—
	100 MHz		—	+62	—
IIP3	Two Tone, +5 dBm/Tone, 5 MHz Spacing Above 500 MHz	dBm	—	+46	—
	100 MHz		—	+40	—
Control Voltage (Complementary Logic)	V_{IN} Low, 0 to -0.2 V	μA	—	—	20
	V_{IN} High, -5 V		—	—	50
	V_{IN} High, -8 V		—	—	300

3. All specifications apply with 50-ohm impedance connected to all RF ports, 0 and -8 VDC control voltages.

4. Loss changes 0.0025 dB/°C (From -55°C to +85°C).

Handling Procedures

Please observe the following precautions to avoid damage:

Static Sensitivity

Gallium Arsenide Integrated Circuits are sensitive to electrostatic discharge (ESD) and can be damaged by static electricity. Proper ESD control techniques should be used when handling these devices.

Truth Table ⁵

Control Inputs		Condition of Switch RF Common to each RF Port	
A	B	RF1	RF2
V_{IN} Hi	V_{IN} Low	On	Off
V_{IN} Low	V_{IN} Hi	Off	On

5. V_{IN} Low = 0 to -0.2 V, V_{IN} High = -5 to -8 V.

Typical Performance Curves

Insertion Loss

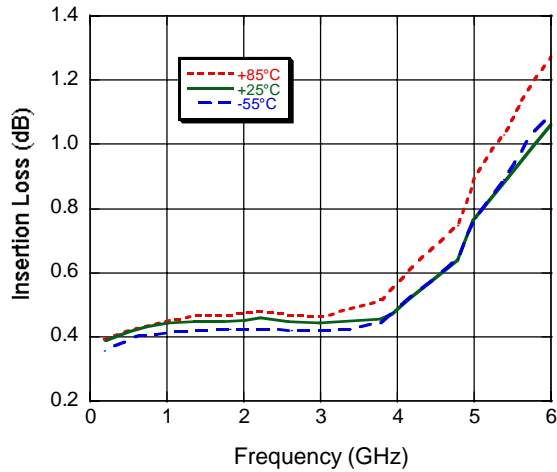

Isolation

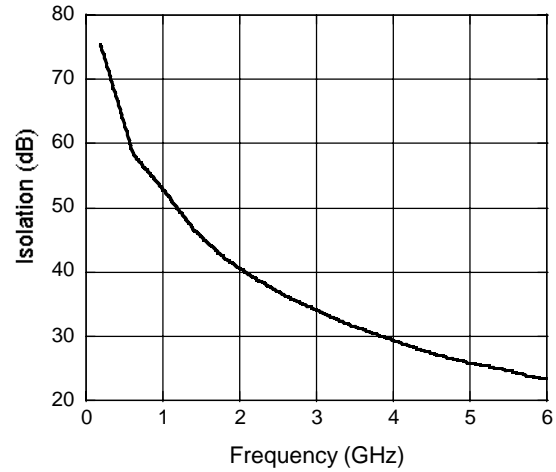

VSWR

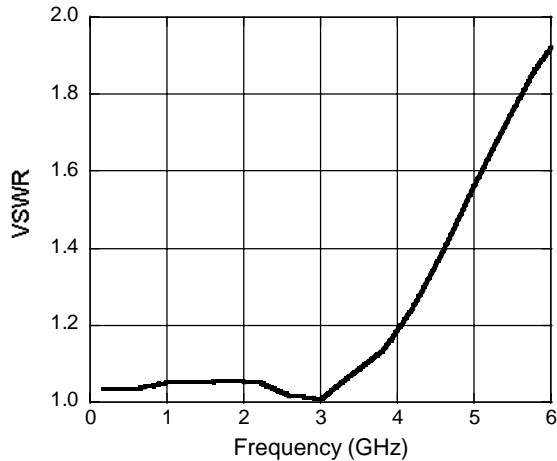

Handling Procedures

Permanent damage to the MASW6010G may occur if the following precautions are not adhered to:

- A. Cleanliness - The MASW6010G should be handled in a clean environment. DO NOT attempt to clean assembly after the MASW6010G is installed.
- B. Static Sensitivity - All die handling equipment and personnel should be DC grounded.
- C. Transients - Avoid instrument and power supply transients while bias is connected to the MASW6010G. Use shielded signal and bias cables to minimize inductive pick-up.
- D. Bias - Apply voltage to either control port A/B or only when the other is grounded. Neither port should be allowed to "float".
- E. General Handling - It is recommended that the MASW6010G chip be handled along the long side of the die with a sharp pair of bent tweezers. DO NOT touch the surface of the chip with fingers or tweezers.

Mounting

The MASW6010G is back-metalized with Pd/Ni/Au (100/1,000/30,000Å) metallization. It can be die-mounted using Au/Sn eutectic preforms or a thermally conductive epoxy. The package surface should be clean and flat before attachment.

Eutectic Die Attach:

- A. An 80/20 Au/Sn preform is recommended with a work surface temperature of approximately 255°C and a tool temperature of 265°C. When hot 90/10 nitrogen/hydrogen gas is applied, solder temperature should be approximately 290°C.
- B. DO NOT expose the MASW6010G to a temperature greater than 320°C for more than 20 seconds. No more than 3 seconds of scrubbing should be required for attachment.

Epoxy Die Attach:

- A. Electrically conductive epoxy must be used.
- B. Apply a minimum amount of epoxy and place the MASW6010G into position. A thin epoxy fillet should be visible around the perimeter of the die.
- C. Cure epoxy per manufacturer's recommended schedule.

Wire Bonding

- A. Ball or wedge bond with 1.0 mil diameter pure gold wire. Thermosonic wire bonding with a nominal stage temperature of 150°C and a ball bonding force of 40 to 50 grams or wedge bonding force of 18 to 22 grams is recommended. Ultrasonic energy and time should be adjusted to the minimum levels to achieve reliable wirebonds.
- B. Wirebonds should be started on the chip and terminated on the package.

Данный компонент на территории Российской Федерации

Вы можете приобрести в компании MosChip.

Для оперативного оформления запроса Вам необходимо перейти по данной ссылке:

<http://moschip.ru/get-element>

Вы можете разместить у нас заказ для любого Вашего проекта, будь то серийное производство или разработка единичного прибора.

В нашем ассортименте представлены ведущие мировые производители активных и пассивных электронных компонентов.

Нашей специализацией является поставка электронной компонентной базы двойного назначения, продукции таких производителей как XILINX, Intel (ex.ALTERA), Vicor, Microchip, Texas Instruments, Analog Devices, Mini-Circuits, Amphenol, Glenair.

Сотрудничество с глобальными дистрибьюторами электронных компонентов, предоставляет возможность заказывать и получать с международных складов практически любой перечень компонентов в оптимальные для Вас сроки.

На всех этапах разработки и производства наши партнеры могут получить квалифицированную поддержку опытных инженеров.

Система менеджмента качества компании отвечает требованиям в соответствии с ГОСТ Р ИСО 9001, ГОСТ РВ 0015-002 и ЭС РД 009

Офис по работе с юридическими лицами:

105318, г.Москва, ул.Щербаковская д.3, офис 1107, 1118, ДЦ «Щербаковский»

Телефон: +7 495 668-12-70 (многоканальный)

Факс: +7 495 668-12-70 (доб.304)

E-mail: info@moschip.ru

Skype отдела продаж:

moschip.ru

moschip.ru_4

moschip.ru_6

moschip.ru_9