

C200HW-SRM21-V1

CS1W-SRM21

CJ1W-SRM21

CQM1-SRM21-V1

SRT1 Series

SRT2 Series

CompoBus/S

OPERATION MANUAL

OMRON

C200HW-SRM21-V1

CS1W-SRM21

CJ1W-SRM21

CQM1-SRM21-V1

SRT1 Series

SRT2 Series

CompoBus/S



Operation Manual

Revised August 2007

Notice:

OMRON products are manufactured for use according to proper procedures by a qualified operator and only for the purposes described in this manual.

The following conventions are used to indicate and classify precautions in this manual. Always heed the information provided with them. Failure to heed precautions can result in injury to people or damage to property.

-  **DANGER** Indicates an imminently hazardous situation which, if not avoided, will result in death or serious injury. Additionally, there may be severe property damage.
-  **WARNING** Indicates a potentially hazardous situation which, if not avoided, could result in death or serious injury. Additionally, there may be severe property damage.
-  **Caution** Indicates a potentially hazardous situation which, if not avoided, may result in minor or moderate injury, or property damage.

OMRON Product References

All OMRON products are capitalized in this manual. The word “Unit” is also capitalized when it refers to an OMRON product, regardless of whether or not it appears in the proper name of the product.

The abbreviation “Ch,” which appears in some displays and on some OMRON products, often means “word” and is abbreviated “Wd” in documentation in this sense.

The abbreviation “PLC” means Programmable Controller and is not used as an abbreviation for anything else.

Visual Aids

The following headings appear in the left column of the manual to help you locate different types of information.

Note Indicates information of particular interest for efficient and convenient operation of the product.

1,2,3... 1. Indicates lists of one sort or another, such as procedures, checklists, etc.

© OMRON, 1996

All rights reserved. No part of this publication may be reproduced, stored in a retrieval system, or transmitted, in any form, or by any means, mechanical, electronic, photocopying, recording, or otherwise, without the prior written permission of OMRON.

No patent liability is assumed with respect to the use of the information contained herein. Moreover, because OMRON is constantly striving to improve its high-quality products, the information contained in this manual is subject to change without notice. Every precaution has been taken in the preparation of this manual. Nevertheless, OMRON assumes no responsibility for errors or omissions. Neither is any liability assumed for damages resulting from the use of the information contained in this publication.

TABLE OF CONTENTS

PRECAUTIONS	XV
1 Intended Audience	xvi
2 General Precautions	xvi
3 Safety Precautions	xvi
4 Operating Environment Precautions	xvii
5 Application Precautions	xviii
6 Conformance to EC Directives	xxi
SECTION 1	
System Design	1
1-1 System Overview and Features	2
1-2 CompoBus/S System Configuration	6
1-3 Compatible Devices	10
1-4 Startup Procedure	20
SECTION 2	
CompoBus/S System Specifications and Configuration	23
2-1 Communications Specifications	24
2-2 System Configuration	25
2-3 Supplying Power to the Slaves	31
2-4 System Configuration Using Water-resistant Terminals	41
2-5 I/O Response Time Characteristics	41
SECTION 3	
CompoBus/S System Wiring	53
3-1 Mounting	54
3-2 Connector Installation (Special Flat Cable Only)	55
3-3 VCTF Cable Assembly	64
3-4 Master/Slave Connecting Cables	66
3-5 Operations Checklist	70
SECTION 4	
Master Unit Specifications and Operations	73
4-1 C200HW-SRM21-V1 Master Unit for CS-series, C200HX/C200HG/C200HE-(Z)E, and C200HS PLCs	74
4-2 CS1W-SRM21 Master Unit for CS-series PLCs	88
4-3 CJ1W-SRM21 Master Unit for CJ-series PLCs	104
4-4 CQM1-SRM21-V1 Master Unit for CQM1 PLCs	126
4-5 SRM1-C0□-V2 Master Control Units	136
4-6 CPM2C-S Series CPM2C-S□□□C (-DRT)	140

TABLE OF CONTENTS

SECTION 5

Slave Specifications and Operations	145
5-1 Remote Terminals	147
5-2 Connector Terminals	194
5-3 Remote I/O Modules	260
5-4 Water-resistant Terminals	268
5-5 Sensor Terminals	287
5-6 Fiber Amplifier Communications Units	301
5-7 Analog Input Terminals	308
5-8 Analog Output Terminals	318
5-9 I/O Link Units for CPM1A and CPM2A	327
5-10 I/O Link Units for CPM2C	331
5-11 Sensor Amplifier Terminals	335
5-12 Application Precautions	350

SECTION 6

Starting Communications	353
6-1 Turning the Power ON	354
6-2 Checking Operations for CS-series, C200HX/C200HG/C200HE-(Z)E, and C200HS Master Units	356
6-3 Checking Operations of CS-series and CJ-series Master Units	365
6-4 Checking Operations of CQM1 Master Units	377
6-5 Checking Slave Operations	382
6-6 Cleaning and Inspection	384
6-7 Precautions for Replacement of Units or Parts	385

Appendix

Standard Models	387
---------------------------	-----

Index	395
------------------------	------------

Revision History	401
-----------------------------------	------------

About this Manual:

This manual describes the installation and operation of the CompoBus/S system and includes the sections described below.

Please read this manual carefully and be sure you understand the information provided before attempting to install and operate the CompoBus/S Master and Slave Units. **Be sure to read the precautions provided in the following section.**

Section 1 provides an overview of the CompoBus/S System and functions, and describes the various Units that are used to configure a CompoBus/S System.

Section 2 provides details on the CompoBus/S System specifications and I/O response times, and explains how to configure a CompoBus/S System.

Section 3 explains how to install Units in control panels, wire the signal and power lines, and make other connections needed to assemble a CompoBus/S System. We recommend reading through the information on wiring each Master and Slave that are provided in *Section 4* and *Section 5*.

Section 4 explains the functions of each Master Unit, including information on specifications, switch settings and allocation of Slave I/O.

Section 5 explains the functions of each Slave, including information on specifications, switch settings, and I/O.

Section 6 provides information on error processing, periodic maintenance operations, and troubleshooting procedures needed to keep the CompoBus/S System operating properly. We recommend reading through the error processing procedures before operation so that operating errors can be identified and corrected more quickly.

The **Appendix** provides tables of standard models including Masters, Slaves, and connecting devices.

In this manual, only the specifications of the CompoBus/S system and devices are described. For details on Units, refer to their respective manuals. (Suffixes have been omitted from the catalog numbers.)

Product Name	Series	Manual Name	Cat. No.
CS-series Programmable Controllers	CS Series	SYSMAC CS Series Operation Manual	W339
CJ-series Programmable Controllers	CJ Series	SYSMAC CJ Series Operation Manual	W393
CS/CJ-series Programmable Controllers	CS/CJ Series	SYSMAC CS/CJ Series Programming Manual	W394
C200HX/C200HG/C200HE-(Z)E Programmable Controllers	C200HX/C200HG/C200HE-(Z)E	SYSMAC C200HX/C200HG/C200HE-(Z)E Programmable Controllers Installation Guide	W302
C200HX/C200HG/C200HE-(Z)E Programmable Controllers	C200HX/C200HG/C200HE-(Z)E	SYSMAC C200HX/C200HG/C200HE-(Z)E Programmable Controllers Operation Manual	W322
C200HS Programmable Controllers	C200HS	SYSMAC C200HS Operation Manual	W235
C200HS Programmable Controllers	C200HS	SYSMAC C200HS Installation Guide	W236
CQM1H Programmable Controller	CQM1H	SYSMAC CQM1H Operation Manual	W363
CQM1H Programmable Controller	CQM1H	SYSMAC CQM1H Programming Manual	W364
CQM1 Programmable Controller	CQM1	SYSMAC CQM1 Operation Manual	W226

Product Name	Series	Manual Name	Cat. No.
CQM1/CPM1/CPM1A/SRM1 Programmable Controller	CQM1/CPM1/CPM1A/SRM1	SYSMAC CQM1/CPM1/CPM1A/SRM1 Programming Manual	W228
CompoBus/S SRM1 Master Control Unit	SRM1(-V2)	SYSMAC CompoBus/S SRM1 Master Control Units Operation Manual	W318
CPM2C-S Programmable Controller	CPM2C-S	SYSMAC CPM2C-S Programmable Controllers Operation Manual	W377
CPM1A/CPM2A I/O Link Unit	CPM1A-SRT21	SYSMAC CPM2A I/O Link Units Operation Manual	W352
CPM2C I/O Link Unit	CPM2C-SRT21	SYSMAC CPM2C I/O Link Units Operation Manual	W356



WARNING Failure to read and understand the information provided in this manual may result in personal injury or death, damage to the product, or product failure. Please read each section in its entirety and be sure you understand the information provided in the section and related sections before attempting any of the procedures or operations given.

Read and Understand this Manual

Please read and understand this manual before using the product. Please consult your OMRON representative if you have any questions or comments.

Warranty and Limitations of Liability

WARRANTY

OMRON's exclusive warranty is that the products are free from defects in materials and workmanship for a period of one year (or other period if specified) from date of sale by OMRON.

OMRON MAKES NO WARRANTY OR REPRESENTATION, EXPRESS OR IMPLIED, REGARDING NON-INFRINGEMENT, MERCHANTABILITY, OR FITNESS FOR PARTICULAR PURPOSE OF THE PRODUCTS. ANY BUYER OR USER ACKNOWLEDGES THAT THE BUYER OR USER ALONE HAS DETERMINED THAT THE PRODUCTS WILL SUITABLY MEET THE REQUIREMENTS OF THEIR INTENDED USE. OMRON DISCLAIMS ALL OTHER WARRANTIES, EXPRESS OR IMPLIED.

LIMITATIONS OF LIABILITY

OMRON SHALL NOT BE RESPONSIBLE FOR SPECIAL, INDIRECT, OR CONSEQUENTIAL DAMAGES, LOSS OF PROFITS OR COMMERCIAL LOSS IN ANY WAY CONNECTED WITH THE PRODUCTS, WHETHER SUCH CLAIM IS BASED ON CONTRACT, WARRANTY, NEGLIGENCE, OR STRICT LIABILITY.

In no event shall the responsibility of OMRON for any act exceed the individual price of the product on which liability is asserted.

IN NO EVENT SHALL OMRON BE RESPONSIBLE FOR WARRANTY, REPAIR, OR OTHER CLAIMS REGARDING THE PRODUCTS UNLESS OMRON'S ANALYSIS CONFIRMS THAT THE PRODUCTS WERE PROPERLY HANDLED, STORED, INSTALLED, AND MAINTAINED AND NOT SUBJECT TO CONTAMINATION, ABUSE, MISUSE, OR INAPPROPRIATE MODIFICATION OR REPAIR.

Application Considerations

SUITABILITY FOR USE

OMRON shall not be responsible for conformity with any standards, codes, or regulations that apply to the combination of products in the customer's application or use of the products.

At the customer's request, OMRON will provide applicable third party certification documents identifying ratings and limitations of use that apply to the products. This information by itself is not sufficient for a complete determination of the suitability of the products in combination with the end product, machine, system, or other application or use.

The following are some examples of applications for which particular attention must be given. This is not intended to be an exhaustive list of all possible uses of the products, nor is it intended to imply that the uses listed may be suitable for the products:

- Outdoor use, uses involving potential chemical contamination or electrical interference, or conditions or uses not described in this manual.
- Nuclear energy control systems, combustion systems, railroad systems, aviation systems, medical equipment, amusement machines, vehicles, safety equipment, and installations subject to separate industry or government regulations.
- Systems, machines, and equipment that could present a risk to life or property.

Please know and observe all prohibitions of use applicable to the products.

NEVER USE THE PRODUCTS FOR AN APPLICATION INVOLVING SERIOUS RISK TO LIFE OR PROPERTY WITHOUT ENSURING THAT THE SYSTEM AS A WHOLE HAS BEEN DESIGNED TO ADDRESS THE RISKS, AND THAT THE OMRON PRODUCTS ARE PROPERLY RATED AND INSTALLED FOR THE INTENDED USE WITHIN THE OVERALL EQUIPMENT OR SYSTEM.

PROGRAMMABLE PRODUCTS

OMRON shall not be responsible for the user's programming of a programmable product, or any consequence thereof.

Disclaimers

CHANGE IN SPECIFICATIONS

Product specifications and accessories may be changed at any time based on improvements and other reasons.

It is our practice to change model numbers when published ratings or features are changed, or when significant construction changes are made. However, some specifications of the products may be changed without any notice. When in doubt, special model numbers may be assigned to fix or establish key specifications for your application on your request. Please consult with your OMRON representative at any time to confirm actual specifications of purchased products.

DIMENSIONS AND WEIGHTS

Dimensions and weights are nominal and are not to be used for manufacturing purposes, even when tolerances are shown.

PERFORMANCE DATA

Performance data given in this manual is provided as a guide for the user in determining suitability and does not constitute a warranty. It may represent the result of OMRON's test conditions, and the users must correlate it to actual application requirements. Actual performance is subject to the OMRON Warranty and Limitations of Liability.

ERRORS AND OMISSIONS

The information in this manual has been carefully checked and is believed to be accurate; however, no responsibility is assumed for clerical, typographical, or proofreading errors, or omissions.

PRECAUTIONS

This section provides general precautions for using the CompoBus/S Units, Programmable Controllers, and related devices.

The information contained in this section is important for the safe and reliable application of the CompoBus/S and PLC. You must read this section and understand the information contained before attempting to set up or operate a CompoBus/S and PLC system.

1	Intended Audience	xvi
2	General Precautions	xvi
3	Safety Precautions	xvi
4	Operating Environment Precautions	xvii
5	Application Precautions	xviii
6	Conformance to EC Directives	xxi
6-1	Applicable Directives	xxi
6-2	Concepts	xxi
6-3	Conformance to EC Directives	xxi

1 Intended Audience

This manual is intended for the following personnel, who must also have knowledge of electrical systems (an electrical engineer or the equivalent).

- Personnel in charge of installing FA systems.
- Personnel in charge of designing FA systems.
- Personnel in charge of managing FA systems and facilities.

2 General Precautions

The user must operate the product according to the performance specifications described in the operation manuals.

Before using the product under conditions which are not described in the manual or applying the product to nuclear control systems, railroad systems, aviation systems, vehicles, combustion systems, medical equipment, amusement machines, safety equipment, and other systems, machines, and equipment that may have a serious influence on lives and property if used improperly, consult your OMRON representative.

Make sure that the ratings and performance characteristics of the product are sufficient for the systems, machines, and equipment, and be sure to provide the systems, machines, and equipment with double safety mechanisms.

This manual provides information for installing and operating OMRON CompoBus/S Units. Be sure to read this manual before operation and keep this manual close at hand for reference during operation.

 **WARNING** It is extremely important that a PLC and all PLC Units be used for the specified purpose and under the specified conditions, especially in applications that can directly or indirectly affect human life. You must consult with your OMRON representative before applying a PLC System to the above-mentioned applications.

3 Safety Precautions

 **WARNING** Do not attempt to take any Unit apart while the power is being supplied. Doing so may result in electric shock.

 **WARNING** Do not touch any of the terminals or terminal blocks while the power is being supplied. Doing so may result in electric shock.

 **WARNING** Provide safety measures in external circuits, i.e., not in the Programmable Controller (CPU Unit including associated Units; referred to as "PLC"), in order to ensure safety in the system if an abnormality occurs due to malfunction of the PLC or another external factor affecting the PLC operation. Not doing so may result in serious accidents.

- Emergency stop circuits, interlock circuits, limit circuits, and similar safety measures must be provided in external control circuits.
- The PLC will turn OFF all outputs when its self-diagnosis function detects any error or when a severe failure alarm (FALS) instruction is executed. As a countermeasure for such errors, external safety measures must be provided to ensure safety in the system.

- The PLC outputs may remain ON or OFF due to deposition or burning of the output relays or destruction of the output transistors. As a countermeasure for such problems, external safety measures must be provided to ensure safety in the system.
- When the 24-VDC output (service power supply to the PLC) is overloaded or short-circuited, the voltage may drop and result in the outputs being turned OFF. As a countermeasure for such problems, external safety measures must be provided to ensure safety in the system.

 **WARNING** Do not attempt to disassemble, repair, or modify any Units. Any attempt to do so may result in malfunction, fire, or electric shock.

 **Caution** Execute online edit only after confirming that no adverse effects will be caused by extending the cycle time. Otherwise, the input signals may not be readable.

 **Caution** Confirm safety at the destination node before transferring a program to another node or editing the I/O area. Doing either of these without confirming safety may result in injury.

 **Caution** Tighten the screws on the terminal block of the AC Power Supply Unit to the torque specified in the operation manual. The loose screws may result in burning or malfunction.

4 Operating Environment Precautions

 **Caution** Do not operate the control system in the following places:

- Locations subject to direct sunlight
- Locations subject to temperatures or humidity outside the range specified in the specifications
- Locations subject to condensation as the result of severe changes in temperature
- Locations subject to corrosive or flammable gases
- Locations subject to dust (especially iron dust) or salts
- Locations subject to exposure to water, oil, or chemicals
- Locations subject to shock or vibration

 **Caution** Take appropriate and sufficient countermeasures when installing systems in the following locations:

- Locations subject to static electricity or other forms of noise
- Locations subject to strong electromagnetic fields
- Locations subject to possible exposure to radioactivity
- Locations close to power supplies

 **Caution** The operating environment of the PLC System can have a large effect on the longevity and reliability of the system. Improper operating environments can lead to malfunction, failure, and other unforeseeable problems with the PLC System. Be sure that the operating environment is within the specified conditions at installation and remains within the specified conditions during the life of the system.

5 Application Precautions

Observe the following precautions when using the CompoBus/S Units or the PLC.

 **WARNING** Failure to abide by the following precautions could lead to serious or possibly fatal injury. Always heed these precautions.

- Always connect to 100 Ω or less when installing the Units. Not connecting to a ground of 100 Ω or less may result in electric shock.
- Always turn OFF the power supplies to the PLC, slaves, and communications before attempting any of the following. Not turning OFF the power supplies may result in malfunction or electric shock.
 - Mounting or dismounting Power Supply Units, I/O Units, CPU Units, memory cassettes, Master Units, or any other Units
 - Mounting or dismounting circuits for Remote I/O Terminals with 3-tier terminal blocks
 - Assembling the Units or Racks
 - Setting DIP switches or rotary switches
 - Connecting or wiring the cables
 - Connecting or disconnecting the connectors

 **Caution** Failure to abide by the following precautions could lead to faulty operation or the PLC or the system or could damage the PLC or PLC Units. Always heed these precautions.

- Failsafe measures must be taken by the customer to ensure safety in the event of incorrect, missing, or abnormal signals caused by broken signal lines, momentary power interruptions, or other causes.
- Provide external interlock circuits, limit circuits, and other safety circuits in addition to any provided within the PLC to ensure safety.
- Configure the control circuits to turn ON the power supply to I/O slaves before turning ON the power supply to the PLC (Master Unit). If the I/O slave power supply is turned ON after the PLC, correct operation may temporarily not be possible.
- Do not attempt to disassemble, repair, or modify any Units. Any attempt to do so may result in malfunction, fire, or electric shock.
- Do not drop the Unit or subject it to excessive vibration or shock.
- Be sure that all the Backplane mounting screws, slave mounting screws, terminal screws, and cable connector screws are tightened to the torque specified in the relevant manuals. Incorrect tightening torque may result in malfunction.
- Wire correctly according to specified procedures.

- Pay careful attention to the polarity (+/-) when connecting the terminal blocks or connectors. Wrong connections may cause malfunction of the system.
- Wire all terminals, communications paths, power supplies lines, and I/O lines with the specified polarity and voltages. Improper wiring may result in faulty operation.
- Install external breakers and take other safety measures against short-circuiting in external wiring. Insufficient safety measures against short-circuiting may result in burning.
- Do not mount the Unit near equipment that generates strong high-frequency noise.
- Leave the label attached to the Unit when wiring to prevent wire clippings and other foreign matter from entering the Unit. Removing the label may result in malfunction.
- Remove the label after the completion of wiring to ensure proper heat dissipation. Leaving the label attached may result in malfunction.
- Use crimp terminals for wiring. Do not connect bare stranded wires directly to terminals. Connection of bare stranded wires may result in burning.
- Wire correctly and double-check all the wiring or the setting switches before turning ON the power supply. Incorrect wiring may result in burning.
- Be sure that the terminal blocks, connectors, expansion cables, and other items with locking devices are properly locked into place. Improper locking may result in malfunction.
- Disconnect the LG and GR terminals on the Power Supply Unit before performing insulation resistance or dielectric strength tests.
- Always use the power supply voltage specified in the operation manual. An incorrect voltage may result in malfunction or burning.
- Take appropriate measures to ensure that the specified power with the rated voltage and frequency is supplied. Be particularly careful in places where the power supply is unstable. An incorrect power supply may result in malfunction.
- Do not apply voltages to the Input Units in excess of the rated input voltage. Excess voltages may result in burning.
- Do not apply voltages exceeding the maximum switching capacity to Output Units. The Output Units may be destroyed.
- Check the user program for proper execution before actually running it on the Unit. Not checking the program may result in an unexpected operation.
- Always turn OFF the power supplies to the PLC, slaves, and communications before attempting any of the following. Not turning OFF the power supply may result in malfunction or electric shock.
 - Mounting or dismounting Power Supply Units, I/O Units, CPU Units, memory cassettes Master Unit, or any other Units
 - Mounting or dismounting circuits for Remote I/O Terminals with 3-tier terminal blocks.
 - Assembling the Units
 - Setting DIP switches or rotary switches
 - Connecting or wiring the cables

- Connecting or disconnecting the connectors
- Before touching the Unit, be sure to first touch a grounded metallic object in order to discharge any static built-up. Not doing so may result in malfunction or damage.
- Confirm that no adverse effect will occur in the system before attempting any of the following. Not doing so may result in an unexpected operation.
 - Changing the operating mode of the PLC. (including the Startup Mode setting)
 - Force-setting/force-resetting any bit in memory.
 - Changing the present value of any word or any set value in memory.
- When replacing parts, be sure to confirm that the rating of a new part is correct. Not doing so may result in malfunction or burning.
- Resume operation only after transferring to the new CPU Unit and/or Special I/O Units the contents of the DM and HR Areas required for resuming operation. Not doing so may result in an unexpected operation.
- When transporting the Units, use special packing boxes and protect them from excessive vibration or shock during transportation.
- Connect all communications cables within the limits given in the specifications.
- Observe the following precautions when wiring communications cables.
 - Separate the communications cables from power lines or high-tension lines.
 - Do not bend the communications cables.
 - Do not pull on the communications cables with an excessive force.
 - Do not place heavy objects on the communications cables.
 - Be sure to put the communications cables inside conduits.
- Water-resistant Terminals used as Slaves are of IP67 construction. Do not attempt to use the Watertight Terminals for applications where the Watertight Terminals are always underwater.
- Install the Unit properly as specified in the operation manual. Improper installation of the Unit may result in malfunction.

6 Conformance to EC Directives

6-1 Applicable Directives

- EMC Directives

6-2 Concepts

EMC Directives

OMRON devices that comply with EC Directives also conform to the related EMC standards so that they can be more easily built into other devices or the overall machine. The actual products have been checked for conformity to EMC standards (see the following note). Whether the products conform to the standards in the system used by the customer, however, must be checked by the customer.

EMC-related performance of the OMRON devices that comply with EC Directives will vary depending on the configuration, wiring, and other conditions of the equipment or control panel on which the OMRON devices are installed. The customer must, therefore, perform the final check to confirm that devices and the overall machine conform to EMC standards.

Note Applicable EMC (Electromagnetic Compatibility) standards are listed in the following table.

Unit	EMS (Electromagnetic Susceptibility)	EMI (Electromagnetic Interference)
C200HW-SRM21-V1	EN61131-2	EN61000-6-4 (See note 2.)
CS1W-SRM21	EN61131-2	
CJ1W-SRM21	EN61000-6-2 (See note 1.)	
CQM1-SRM21-V1	EN61131-2	
SRM1-C0□-V2	EN61000-6-2 (See note 1.)	
CPM2C-S□□□C(-DRT)	EN61131-2	
SRT1 and SRT2 Series	EN61000-6-2 (See note 1.)	

- Note**
1. These products have configurations with less than 30 m of I/O wiring, and less than 10 m of power supply wiring.
 2. Radiated emission for EN61000-6-4: 10-m regulations

6-3 Conformance to EC Directives

Observe the follow precautions when installing the CompoBus/S Units that conform to the EC Directives.

- 1,2,3...**
1. Since the CompoBus/S Units are classified as built-in types, be sure to install the Units inside a control panel.
 2. Provide reinforced insulation or double insulation for the DC Power Supplies that are used as power sources for the alarm output, communications circuits, and I/O circuits.
 3. The CompoBus/S Units that conform to the EC Directives also conforms to the Common Emission Standard (EN61000-6-4). When incorporated into a device, however, the requirements may vary depending on the configuration of the control panel to be used, relationship with other devices to be connected, wiring, etc. Users are therefore requested to confirm Unit conformance to the EC Directives by themselves.

SECTION 1

System Design

This section provides an overview of the CompoBus/S System and functions, and describes the various Masters, Slaves, and connection devices that are used to configure a CompoBus/S System.

1-1	System Overview and Features	2
1-1-1	System Overview	2
1-1-2	Network Features	3
1-1-3	Communications Modes	5
1-2	CompoBus/S System Configuration	6
1-2-1	Basic System Configuration	6
1-2-2	CompoBus/S System Components	8
1-3	Compatible Devices	10
1-3-1	Compatible Masters	10
1-3-2	Slave Units	13
1-3-3	Cables	16
1-3-4	Connectors/Terminal Blocks	17
1-4	Startup Procedure	20

1-1 System Overview and Features

1-1-1 System Overview

The CompoBus/S System is a remote I/O communications system with reduced wiring that retains the functionality and ease of use of the original remote I/O system (wired type), while providing higher-speed, longer-distance, and highly reliable communications.

The CompoBus/S System allows connection of up to 32 I/O devices (Slaves) to a Master Unit using only two signal wires, even on long production lines that require multiple I/O control.

Connect up to 32 Slaves (256 Points) for Each Master Unit

Each CompoBus/S Master Unit can be connected to up to 32 Slaves of various types, including I/O Terminals and Sensor Terminals, and allows I/O communications for up to 256 points (128 inputs, 128 outputs).

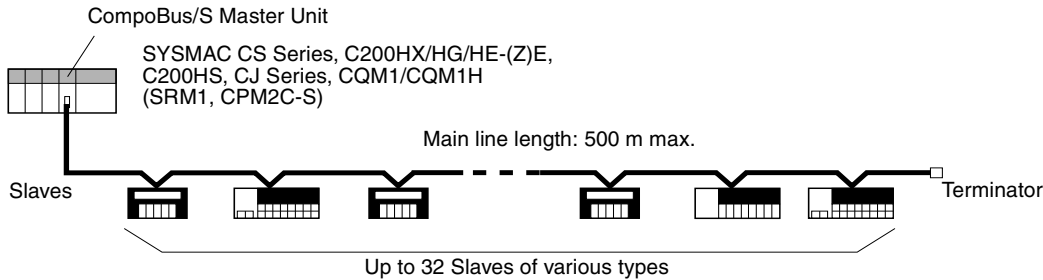

Flexible Wiring Configuration

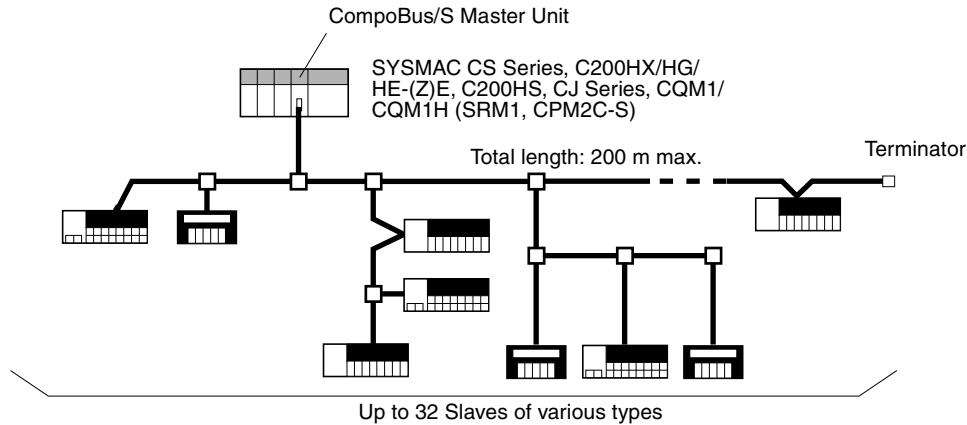

I/O Data Exchange without Special Programming

I/O data can be exchanged between the Master and Slaves without requiring any special ladder programming for communications. I/O information for each Slave is exchanged between Slaves and the corresponding I/O Area in the Master by simply setting the node number of each Slave.

Input Slave

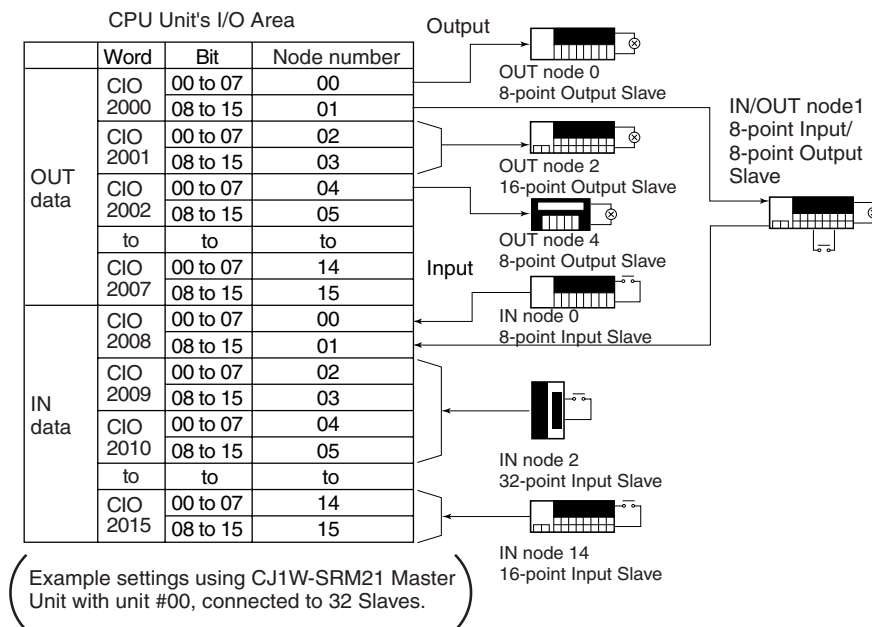

1-1-2 Network Features

The CompoBus/S has the following features.

Communications Modes

Select either a High-speed Communications Mode or Long-distance Communications Mode for the CompoBus/S according to the system configuration. The differences between the High-speed Communications Mode and the Long-distance Communications Mode are described in *1-1-3 Communications Modes*.

Flexible Wiring Up to 200 m

In Long-distance Communications Mode, flexible wiring is possible up to a total cable length of 200 m with no restrictions on branching or node connections, provided that 4-conductor VCTF cable or Special Flat Cable is used.

Long-distance Communications Up to 500 m

In Long-distance Communications Mode, communications over the main line of up to 500 m are possible to control I/O devices in a wide area, provided that 2-conductor VCTF cable is used. In this case, however, each branch line can be connected to a single Slave only, because the branch line cannot be further branched. Furthermore, the Master must be connected to either end of the main line.

High-speed Communications

In High-speed Communications Mode, up to 16 Slaves with 128 I/O points can be connected with a high-speed communications cycle time of only 0.5 ms. This cycle is fast enough for time-critical factory automation applications.

Water-resistance Slaves

Water-resistant Terminals (IP67) can be used as Slaves to exchange I/O in places exposed to water. Water-resistant Terminals are, however, available only when the communications cable is 4-conductor VCTF cable.

Reduced Wiring

A Slave can be connected to a Master or another Slave with just one connecting cable. If the 4-wire Special Flat Cable or 4-conductor VCTF cable is used, the Slave's communication power supply is also supplied through the cable, so floor wiring can be reduced dramatically. Also, special connectors simplify branching from a main cable.

Connecting to 4-conductor VCTF Cable

Easy-to-obtain 4-conductor VCTF cable can be used instead of the Special Flat Cable. Furthermore improvement in the environmental resistance of the system is possible by using shielded connectors.

Use Both T-branch and Multidrop Methods

Both the T-branch and multidrop methods can be combined flexibly when wiring. In combination with the floor cables, this wiring feature allows a very flexible system configuration. There are three types of cables (2-conductor VCTF cable, 4-conductor VCTF cable, and Special Flat Cable), and when the Special Flat Cable is used, T-branch Connectors can be installed by simply snapping the connector on.

Wide Variety of Masters

Master Units are available as Special I/O Units for the CS-series, C200HX/C200HG/C200HE-(Z)E, C200HS, CS-series, CJ-series, and CQM1 PLCs and also available integrated with a CPU for the SRM1 and CPM2C-S. The variety of Masters provides flexibility in configuring a system to match your application needs.

Wide Variety of Slaves

Units in a wide range are available as I/O Slaves for a variety of applications. Such Units include Remote Terminals and Sensor Terminals, which vary with the number of I/O points or I/O type, Connector Terminals, which allow easy wiring, and Water-resistant Terminals, which have a better protective construction. There are many Slaves available with advanced functions, including Analog I/O Terminals for analog-to-digital or digital-to-analog conversion, and CPM1A/CPM2A/CPM2C I/O Link Units for sharing data with the host PLC.

Easy Startup

The CompoBus/S System can be started just by wiring the cables and making some simple settings. Replacement of earlier Remote I/O Systems is also easy.

Slave Node Number Provided on Indicators and in PLC Memory

Troubleshooting is easy because the Slave's node number is shown on the Master's indicators if an error occurs with a Slave. When a CS-series, C200HX/HG/HE-(Z)E, or C200HS Master Unit is used, error information is also stored in PLC memory.

When an error occurs with a Slave using a CS-series or CJ-series Master Unit, the Slave's node number is stored in the DM Area using the Slave registration function.

Slave Monitoring for Improved Reliability

Reliability of the CS-series and CJ-series Master Units has been further improved by the addition of the following functions.

Slave Registration Function

Registering Slaves in the Master allows the user to check whether connected Slaves are joined to the network, and to detect whether Slaves are illegally joined due to incorrect connection, or missing from the network due to a delay in startup or malfunction of registered Slaves.

Communications Stop Mode

System malfunctions can be avoided by setting remote I/O communications to stop when a communications error occurs.

1-1-3 Communications Modes

Both High-speed Communications Mode and the Long-distance Communications Mode are supported by the CompoBus/S.

Item	High-speed Communications Mode	Long-distance Communications Mode
Communications baud rate	750 kbps	93.75 kbps
Communications cycle time	0.5 ms or 0.8 ms (depending on maximum number of I/O points)	4.0 ms or 6.0 ms (depending on maximum number of I/O points)

The communications distance and the connection configuration vary with the communications mode and communications cable.

Cable	High-speed Communications Mode	Long-distance Communications Mode
2-conductor VCTF cable	Length of main line: 100 m max. Length of branch line: 3 m max. Total length of branch lines: 50 m max.	Length of main line: 500 m max. Length of branch line: 6 m max. Total length of branch lines: 120 m max.
4-conductor VCTF cable	Length of main line: 30 m max. Length of branch line: 3 m max. Total length of branch lines: 30 m max.	Flexible branching, provided that the total length of cable is a maximum of 200 m.
Special Flat Cable	Length of main line: 30 m max. Length of branch line: 3 m max. Total length of branch lines: 30 m max.	Flexible branching, provided that the total length of cable is a maximum of 200 m.

Note The I/O response time may be slower when using Long-distance Communications Mode compared with High-speed Communications Mode. Refer to *2-5 I/O Response Time Characteristics*.

1-2 CompoBus/S System Configuration

1-2-1 Basic System Configuration

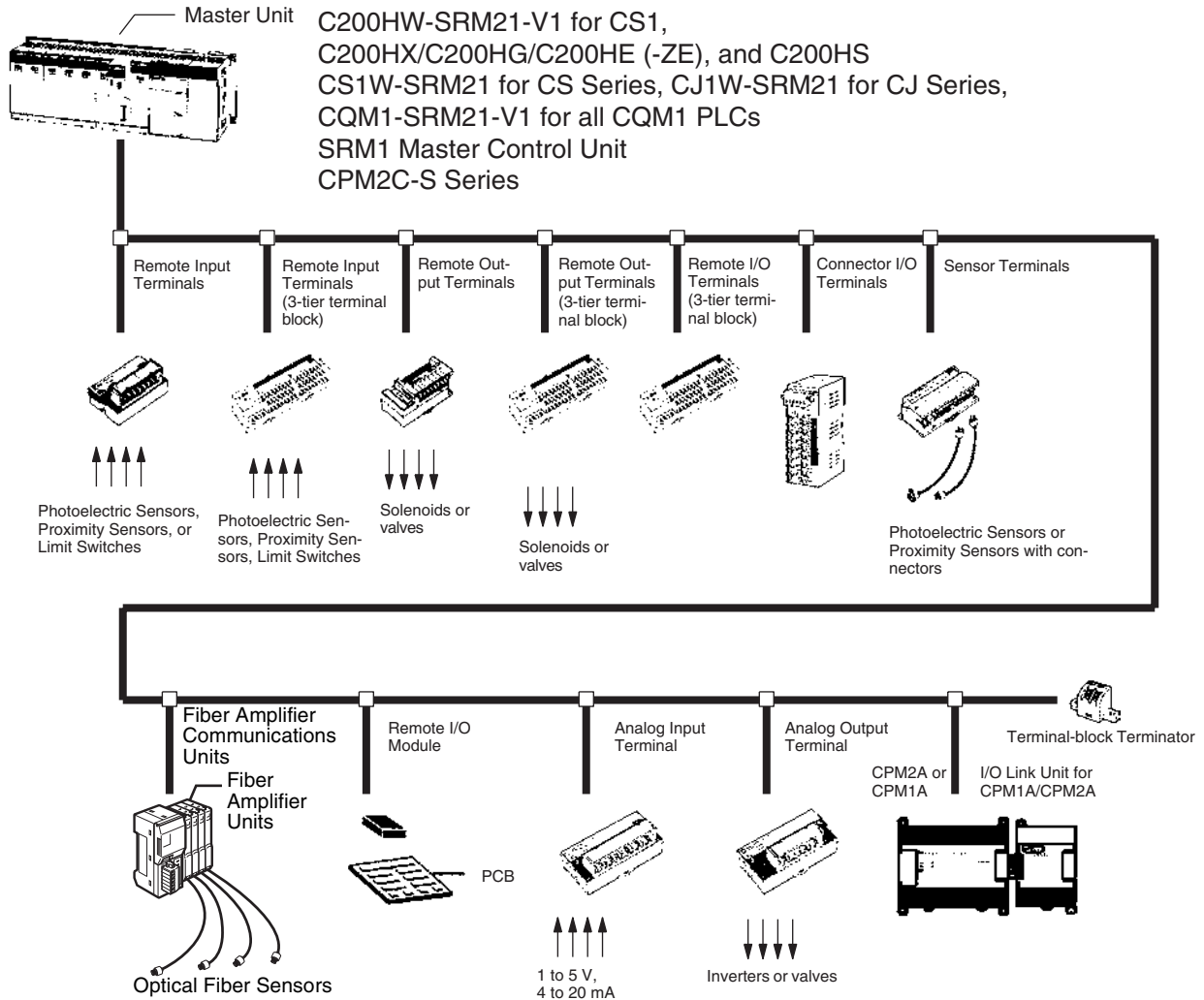

Master Characteristics

CS-series, C200HX/HG/HE-(Z)E, C200HS Master Units

- Multiple Masters (up to 16) can be connected to a single PLC.
- Up to 128 or 256 I/O points (DIP switch used to switch setting).
- Communications status stored in CPU Unit's I/O Area.

CS-series Master Units

- Multiple Masters (up to 96) can be connected to a single PLC.
- Up to 128 or 256 I/O points (DIP switch used to switch setting).
- Communications status stored in CPU Unit's I/O Area.
- Uses the Slave registration function to monitor which Slaves are joined to the network.
- Communications can be stopped when a communications error occurs.

CJ-series Master Units

- Multiple Masters (up to 40) can be connected to a single PLC.
- Up to 128 or 256 I/O points (DIP switch used to switch setting).
- Communications status stored in CPU Unit's I/O Area.

- Uses the Slave registration function to monitor which Slaves are joined to the network.
- Communications can be stopped when a communications error occurs.

CQM1 Master Units

- Only one Master can be connected to a single PLC.
- Up to 32, 64, or 128 I/O points (DIP switch used to switch setting).
- Alarm output terminal provided to detect errors.

SRM1 and CPM2C-S Master Units with Built-in CPU Units

- Compact CPU Unit with built-in CompoBus/S communications functions.
- Up to 256 I/O points for CompoBus/S functions.
- Communications status stored in CPU Unit's AR Area.

Slave Characteristics

Remote Terminals

- Input or Output Terminals for general-purpose use.
- 4-point, 8-point, and 16-point Transistor Remote Terminals.
- Remote Terminals with no-contact transistor I/O, connector transistor outputs, or relay contact outputs.

Remote Terminals (3-tier Terminal Blocks)

- Input or Output Terminals for general-purpose use.
- 16 points: 8 inputs and 8 outputs mixed.
- Wiring is simple because common terminals for I/O wiring are located at each point on the 3-tier terminal block.

Connector Terminals

- All I/O wiring can be done using connectors, reducing the amount of labor for wiring.
- Mounting brackets allow the direction of mounting to be changed.

Water-resistant Terminals

- Input or output terminals of IP67 construction.
- 4 or 8 inputs or outputs.
- Connecting to communications cable, I/O power supply, and I/O through shielded connectors.

Remote I/O Modules

- Modular type that allows PCB mounting.
- 16-input model and 16-output model.
- User's devices can be customized as CompoBus/S Slaves.

Sensor Terminals

- Easily connects to Photoelectric Sensor or Proximity Sensor with XS8 Connectors.
- 8-input/8-output model and 4-input/4-output model.
- Remote teaching and external diagnosis are possible by using output signals of the Sensor Terminal.

Fiber Amplifier Communications Units

- Reduced wiring with ON/OFF output and power supply wiring not required.
- Connecting a Fiber Amplifier Unit allows connection of up to 14 Optical Fiber Sensors.

- Mobile Console can be connected without the Head (Photoelectric Sensor setting, teaching, and adjustment can be executed on site.)

Analog Input Terminals

- Convert analog inputs to binary data.
- The number of analog input points can be switched between 4 points, 3 points, 2 points, and 1 point using a DIP switch.
- The following input ranges are supported:
0 to 5 V, 1 to 5 V, 0 to 10 V, -10 to 10 V, 0 to 20 mA, 4 to 20 mA

Analog Output Terminals

- Convert binary data to analog outputs.
- The number of analog output points can be switched between 2 points and 1 point using a DIP switch.
- Supports the following output ranges:
1 to 5 V, 0 to 10 V, -10 to 10 V, 0 to 20 mA, 4 to 20 mA

I/O Link Terminals for CPM1A/CPM2A

- Create I/O Links (8 inputs, 8 outputs) with CPM1A and CPM2A PLCs.

CPM2C I/O Link Unit

- Creating I/O Links (8 inputs, 8 outputs) with CPM2C-series PLCs.

1-2-2 CompoBus/S System Components

System with Distinct Main and Branch Lines

The diagram below shows a CompoBus/S System in which the main line must be distinguished from the branch lines under either of the following conditions.

- The system operates in High-speed Communications Mode.
- The system operates in Long-distance Communications Mode with 2-conductor VCTF cable. (The maximum length of the main line varies with the type of communications cable.)

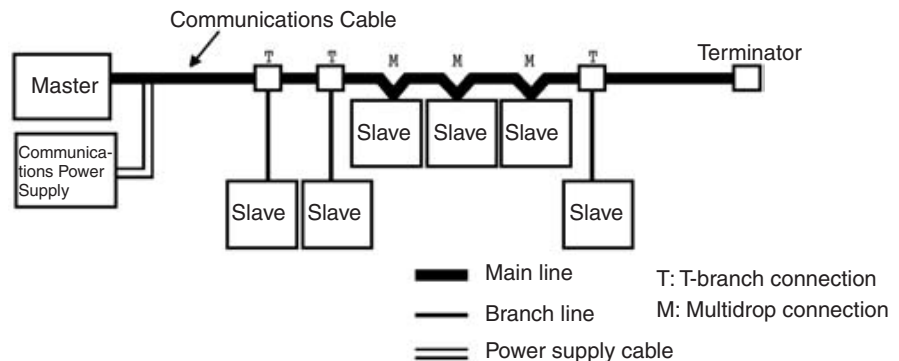

Master

The Master administers the CompoBus/S System and manages the external I/O of the Slaves. There is only 1 Master in a CompoBus/S System and the Master must be connected at the end of the main line, as shown in the preceding diagram.

Slaves

The external I/O connected to the Slaves is processed by communicating with the Master through the CompoBus/S System.

Main/Branch Lines

The main line is the main cable that connects the two most distant points of the system. Cables branching from the main line are known as branch lines.

Cables

CompoBus/S communications are transmitted through 2-conductor VCTF, 4-conductor VCTF, or Special Flat Cable. When 4-conductor VCTF or Special

Flat Cable is used, the communications power supply can be supplied through the cable. The system shown in the preceding diagram uses 4-conductor VCTF or Special Flat Cable. When 2-conductor VCTF cable is used, power must be supplied to the Slaves through a separate cable.

Connection Methods

Two methods can be used to connect CompoBus/S Slaves: the T-branch method and the multidrop method. With the T-branch method, the Slave is connected to a branch line which branches off from the main line. With the multidrop method, the Slave is connected directly to the main line.

These two connection methods can both be used in the same system, although it is not possible to make a secondary branch from a branch line. Use OMRON’s Branch Connector, a T-joint for a shielded connector, or a commercially available terminal block to create a branch from the main line.

Terminator

A terminator must be connected to the end of the main line opposite the Master in order to stabilize communications. There are three kinds of terminating resistors available, a connector for use with Special Flat Cable, a terminal block, and a shielded connector.

System with No Distinction between Main and Branch Lines

The diagram below shows a CompoBus/S System in which it is not necessary to distinguish between the main line and branch lines. This applies to the following conditions.

- The system operates in Long-distance Communications Mode with 4-conductor VCTF cable.
- The system operates in Long-distance Communications Mode with Special Flat Cable.
(The maximum length of cable is 200 m regardless of the type of communications cable.)

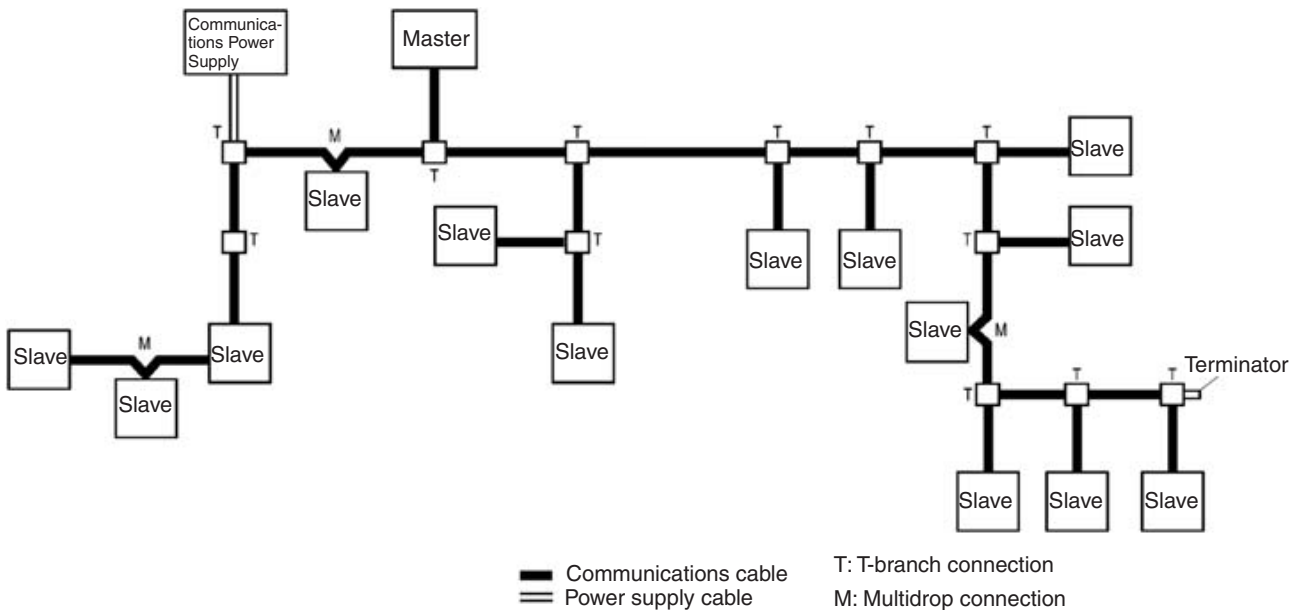

Master

The Master administers the CompoBus/S System and manages the external I/O of the Slaves. There is only one Master in a CompoBus/S System and the Master can be connected anywhere.

Slaves

The external I/O connected to the Slaves is processed by communicating with the Master through the CompoBus/S System.

Cables

CompoBus/S communications are transmitted through Special Flat Cable or 4-conductor VCTF cable. The communications power supply can be supplied through either of the cables.

Connection Methods

Two methods can be used to connect the CompoBus/S Master and Slaves: the T-branch method and the multidrop method. With the T-branch method, the Slave is connected to a line that branches off from the communications cable wherever desired. With the multidrop method, the Master or Slave is connected directly to the communications cable. These two connection methods can both be used in the same system and it is possible to make a secondary branch from a branch line. Use OMRON's Branch Connector for Special Flat Cable, a T-joint for a shielded connector, or a commercially available terminal block to create a branch from the communications cable.

Terminator

A terminator must be connected to the end of the communications cable farthest from the Master in order to stabilize communications. There are three kinds of terminating resistors available, a connector for use with Special Flat Cable, a terminal block, and a shielded connector. In a system in which distinguishing between the main and branch lines is not necessary, only a single terminator farthest from the Master is required regardless of the position the Master is connected to the communications cable.

1-3 Compatible Devices

1-3-1 Compatible Masters

Masters with Communications Functions

There are three types of Master Units which can be used in CompoBus/S Systems. The model of the Master Unit which must be used depends on the PLC being used.

PLC	C200HX-CPU3□-(Z)E/ CPU4□-(Z)E, C200HG-CPU3□-(Z)E/CPU4□-(Z)E, C200HE, C200HS	C200HX-CPU5□-(Z)E/ CPU6□-(Z)E/ CPU8□-(Z)E, C200HG-CPU5□-(Z)E/ CPU6□-(Z)E, CS Series	CS Series	CJ Series	CQM1, CQM1H
Master Unit	C200HW-SRM21-V1		CS1W-SRM21	CJ1W-SRM21	CQM1-SRM21-V1
Communications mode	High-speed Communications Mode or Long-distance Communications Mode (switched using the DIP switch on front panel)				
Analog I/O Terminal connection	Possible				
Max. number of Masters	10 Units (when using a single Special I/O Unit node number (i.e., 10 words)) 5 Units (when using two Special I/O Unit node number (i.e., 20 words))	16 Units (when using a single Special I/O Unit node number (i.e., 10 words)) 8 Units (when using two Special I/O Unit node number (i.e., 20 words))	96 Units (when using a single Special I/O Unit node number (i.e., 10 words)) 95 Units (when using two Special I/O Unit node number (i.e., 20 words))	40 Units	CQM1: 1 Unit CQM1H: Up to the number corresponding to the maximum I/O points for the CPU Unit.
Master Unit mounting location	Can be mounted on the CPU Backplane or Expansion I/O Backplane. Can't be mounted on a SYSMAC BUS Slave (RT) Rack.		Can be connected in the CPU Rack or Expansion Rack.		No restrictions.

PLC	C200HX-CPU3□-(Z)E/ CPU4□-(Z)E, C200HG-CPU3□-(Z)E/CPU4□-(Z)E, C200HE, C200HS	C200HX-CPU5□-(Z)E/ CPU6□-(Z)E/ CPU8□-(Z)E, C200HG-CPU5□-(Z)E/ CPU6□-(Z)E, CS Series	CS Series	CJ Series	CQM1, CQM1H
Max. number of I/O points per Master	256 points (128 inputs/128 outputs) or 128 points (64 inputs/64 outputs) The max. number of I/O points depends on the DIP switch settings. The area allocated to Special I/O Units is used for I/O.			CQM1-CPU11-E/ 21-E: 32 points (16 inputs/ 16 outputs) or 64 points (32 inputs/ 32 outputs) CQM1-CPU41-EV1/ 42-EV1/ 43-EV1/44-EV1: 32 points (16 inputs/16 outputs) or 64 points (32 inputs/32 outputs) or 128 points (64 inputs/ 64 outputs) The max. number of I/O points depends on the DIP switch settings. The IR area is used for I/O.	
Number of points per node number	8-point mode	8-point mode		8-point mode or 4-point mode	
Number of usable node numbers per Master	IN0 to IN7 and OUT0 to OUT7 or IN0 to IN15 and OUT0 to OUT15	IN0 to IN7 and OUT0 to OUT7 or IN0 to IN15 and OUT0 to OUT15		When 8 points are used per node: IN0 to IN1/OUT0 to OUT1 or IN0 to IN3/OUT0 to OUT3 or IN0 to IN7/OUT0 to OUT7 When 4 points are used per node: IN0 to IN3/OUT0 to OUT3 or IN0 to IN7/OUT0 to OUT7 or IN0 to IN15/OUT0 to OUT15	
Master Unit power supply	Not required. (Power is supplied from the PLC.)	Not required. (Power is supplied from the PLC.)		Not required. (Power is supplied from the PLC.)	

PLC	C200HX-CPU3□-(Z)E/ CPU4□-(Z)E, C200HG-CPU3□-(Z)E/CPU4□-(Z)E, C200HE, C200HS	C200HX-CPU5□-(Z)E/ CPU6□-(Z)E/ CPU8□-(Z)E, C200HG-CPU5□-(Z)E/ CPU6□-(Z)E, CS Series	CS Series	CJ Series	CQM1, CQM1H
Terminal for connecting communications power supply for Slaves	Not provided			Provided	Not provided
Status indicators	The PLC's AR Area contains the active node flags and communications error flags for each Slave.	The PLC's Auxiliary Area contains the active node flags and communications error flags for each Slave. The DM Area contains an area for Slave registration and setting communications stop mode.		There is an alarm output terminal in the terminal block.	

- Note**
1. Previous Master Unit models (without -V1), which do not support the Long-distance Communications Mode, cannot be used when an Analog I/O Terminal is connected as a Slave. If used, incorrect data may be transmitted.
 2. Refer to *SECTION 4 Master Unit Specifications and Operations* for more details on the Master Units.

Master with Built-in CPU

The following Master Control Unit models, which have a built-in CPU Unit, are used for distributed I/O control in CompoBus/S Systems. Refer to the *SRM1 Master Control Unit Operation Manual (W318-E1-□)* and the *CPM2C-S PLC Operation Manual (W377-E1-□)* for details.

SRM1 Master Control Unit

Item	Master Control Unit	
	SRM1-CPU01-V2	SRM1-CPU02-V2
Peripheral port	Yes	Yes
RS-232C port	---	Yes
Program capacity	4K words	
Max. number of I/O points	256 (128 inputs/128 outputs)	
Communications mode	High-speed Communications Mode or Long-distance Communications Mode (switched using PLC Setup)	
Number of points per node number	8-point mode	
Number of usable node numbers per Master	IN0 to IN7 and OUT0 to OUT7 or IN0 to IN15 and OUT0 to OUT15	
Status indicators	The PLC's AR Area contains the active node flags and communications error flags for each Slave.	

CPM2C-S PLC

The CPM2C-S PLC has built-in CompoBus/S Master and DeviceNet Slave functions. Models that support I/O links with host PLCs are available as well.

Item	Master Control Unit	
	CPM2C-S□□□C	CPM2C-S□□□C-DRT
Peripheral port	The same connector is used.	
RS-232C port		
Program capacity	4K words	
Max. number of I/O points	256 (128 inputs/128 outputs)	
Communications mode	High-speed Communications Mode or Long-distance Communications Mode (switched using PLC Setup)	

Item	Master Control Unit	
	CPM2C-S□□□C	CPM2C-S□□□C-DRT
Number of points per node number	8-point mode	
Number of usable node numbers per Master	IN0 to IN7 and OUT0 to OUT7 or IN0 to IN15 and OUT0 to OUT15	
Status indicators	The PLC's AR Area contains the active node flags and communications error flags for each Slave.	
DeviceNet Slave function	Not provided	Provided

Master Units and Corresponding Communications Modes

Master Units support only High-speed Communications Mode or both High-speed Communications Mode and Long-distance Communications Mode. Slave Analog Terminals can be connected to the Units that support both High-speed and Long-distance Communications Modes. These Units are an upgraded version and, by switching the communications mode, can be used instead of the Units that support only the High-speed Communications Mode.

Item		Unit supporting High-speed Communications only	Unit supporting High-speed and Long-distance Communications
Communications modes	High-speed Communications Mode	Yes	Yes
	Long-distance Communications Mode	No	Yes
Analog I/O Terminal connections		No	Yes

The following models are available.

PLC	Units supporting High-speed Communications	Units supporting High-speed and Long-distance Communications
CS-series, C200HX/C200HG/C200HE-(Z)E, and C200HS Master Units	C200HW-SRM21	C200HW-SRM21-V1
CS-series Master Units	---	CS1W-SRM21
CJ-series Master Units	---	CJ1W-SRM21
CQM1 Master Units	CQM1-SRM21	CQM1-SRM21-V1
SRM1	SRM1-C0□ SRM1-C0□-V1	SRM1-C0□-V2
CPM2C-S	---	CPM2C-S□□□ (-DRT)

Note Master Units that do not support Long-distance Communications Mode cannot be used when connecting an Analog Terminal as a Slave. If used, incorrect data may be transmitted.

1-3-2 Slave Units

The SRT1/SRT2 Series provides Slaves that support only High-speed Communications Mode or both High-speed Communications Mode and Long-distance Communications Mode. The SRT2-series Slaves that support High-speed and Long-distance Communications Modes are an upgraded version

and, by switching the communications mode, can be used instead of the Slaves that support only the High-speed Communications Mode.

Item		Slaves supporting High-speed Communications	Slaves supporting High-speed and Long-distance Communications
Slave Series		SRT1 Series	SRT2 Series
Communications modes	High-speed Communications Mode	Yes	Yes
	Long-distance Communications Mode	No	Yes

Available models are shown in the following table.

Type	Previous models	New models	I/O points	Power supply
Slave	SRT1 Series	SRT2 Series		
Remote Terminals with Transistors	SRT1-ID04	SRT2-ID04	4 inputs (NPN)	Multiple supplies
	SRT1-ID04-1	SRT2-ID04-1	4 inputs (PNP)	
	SRT1-ID08	SRT2-ID08	8 inputs (NPN)	
	SRT1-ID08-1	SRT2-ID08-1	8 inputs (PNP)	
	SRT1-ID16	SRT2-ID16	16 inputs (NPN)	
	SRT1-ID16-1	SRT2-ID16-1	16 inputs (PNP)	
	SRT1-ID16T	SRT2-ID16T	16 inputs (NPN, 3-tier terminal block)	
	SRT1-ID16T-1	SRT2-ID16T-1	16 inputs (PNP, 3-tier terminal block)	
	SRT1-OD04	SRT2-OD04	4 outputs (NPN)	
	SRT1-OD04-1	SRT2-OD04-1	4 outputs (PNP)	
	SRT1-OD08	SRT2-OD08	8 outputs (NPN)	
	SRT1-OD08-1	SRT2-OD08-1	8 outputs (PNP)	
	SRT1-OD16	SRT2-OD16	16 outputs (NPN)	
	SRT1-OD16-1	SRT2-OD16-1	16 outputs (PNP)	
	SRT1-OD16T	SRT2-OD16T	16 outputs (NPN, 3-tier terminal block)	
	SRT1-OD16T-1	SRT2-OD16T-1	16 outputs (PNP, 3-tier terminal block)	
	SRT1-MD16T	SRT2-MD16T	8 inputs, 8 outputs (NPN, 3-tier terminal block)	
	SRT1-MD16T-1	SRT2-MD16T-1	8 inputs, 8 outputs (PNP, 3-tier terminal block)	

Type	Previous models	New models	I/O points	Power supply
Slave	SRT1 Series	SRT2 Series		
Connector Terminals (8-point/16-point Transistors)	None	SRT2-VID08S	8 inputs (NPN, sensor connectors)	Multiple supplies
		SRT2-VID08S-1	8 inputs (PNP, sensor connectors)	
		SRT2-VID16ML	16 inputs (NPN, MIL connectors)	
		SRT2-VID16ML-1	16 inputs (PNP, MIL connectors)	
		SRT2-VOD08S	8 outputs (NPN, sensor connectors)	
		SRT2-VOD08S-1	8 outputs (PNP, sensor connectors)	
		SRT2-VOD16ML	16 outputs (NPN, MIL connectors)	
		SRT2-VOD16ML-1	16 outputs (PNP, MIL connectors)	
Connector Terminals (32-point Transistors)	None	SRT2-ID32ML	32 inputs (NPN, MIL connectors)	
		SRT2-ID32ML-1	32 inputs (PNP, MIL connectors)	
		SRT2-OD32ML	32 outputs (NPN, MIL connectors)	
		SRT2-OD32ML-1	32 outputs (PNP, MIL connectors)	
		SRT2-MD32ML	16 inputs, 16 outputs (NPN, MIL connectors)	
		SRT2-MD32ML-1	16 inputs, 16 outputs (PNP, MIL connectors)	
Remote Terminals with Relays	SRT1-ROC08	SRT2-ROC08	8 outputs	Local
	SRT1-ROC16	SRT2-ROC16	16 outputs	
Remote Terminals with Power MOS FETs	SRT1-ROF08	SRT2-ROF08	8 outputs	
	SRT1-ROF16	SRT2-ROF16	16 outputs	
Water-resistant Terminals (Transistors)	None	SRT2-ID04CL	4 inputs (NPN)	Multiple supplies
		SRT2-ID04CL-1	4 inputs (PNP)	
		SRT2-ID08CL	8 inputs (NPN)	
		SRT2-ID08CL-1	8 inputs (PNP)	
		SRT2-OD04CL	4 outputs (NPN)	
		SRT2-OD04CL-1	4 outputs (PNP)	
		SRT2-OD08CL	8 outputs (NPN)	
		SRT2-OD08CL-1	8 outputs (PNP)	
Sensor Terminals	SRT1-ID08S	SRT2-ID08S	8 inputs	Network
	SRT1-ND08S	SRT2-ND08S	4 inputs, 4 outputs	
	SRT1-OD08S	SRT2-OD08S	8 outputs (NPN, connector outputs)	Local
Remote I/O Modules	SRT1-ID16P	SRT2-ID16P	16 inputs (NPN, PCB attachment)	---
	SRT1-OD16P	SRT2-OD16P	16 outputs (NPN, PCB attachment)	

Type	Previous models	New models	I/O points	Power supply
Slave	SRT1 Series	SRT2 Series		
Fiber Amplifier Communications Unit	None	E3X-SRT21	8-point input or 16 point input (with Fiber Amplifier Unit connected)	Network
Analog Input Terminals	None	SRT2-AD04	Switchable between 4-point, 3-point, 2-point, and 1-point analog input	
Analog Output Terminals	None	SRT2-DA02	Switchable between 2-point and 1-point analog output	
I/O Link Units	None	CPM1A-SRT21	8 inputs, 8 outputs (For CPM1A/CPM2A)	---
CPM2C I/O Link Units	None	CPM2C-SRT21	8 inputs, 8 outputs (For CPM2C)	---

- Note**
1. The power supply requirements are described below. Refer to 2-3 *Supplying Power to the Slaves* for details on these power supplies.
 2. Refer to *SECTION 5 Slave Specifications and Operations* for details on Slaves.

Network Power Supply

These Slaves use a single power supply and can be supplied with power from the Special Flat Cable for CompoBus/S.

Multiple Power Supplies

These Slaves require two separate power supplies for communications and I/O. The communications power can be supplied from the Special Flat Cable for CompoBus/S.

Local Power Supply

These Slaves require a single external power supply. The power cannot be supplied from the Special Flat Cable for CompoBus/S.

1-3-3 Cables

Cables

The following table lists the cables that can be used in a CompoBus/S System.

Cable	Specifications
2-conductor VCTF cable (sold commercially)	Vinyl-clad VCTF JIS C 3306 Two 0.75 mm ² conductors (2 signal wires) Resistance: 25.1 Ω/km at 20°C Use only 2-conductor VCTF cable.
4-conductor VCTF cable (sold commercially)	Vinyl-clad VCTF JIS C 3306 Four 0.75 mm ² conductors (2 signal wires and 2 power supply wires) Resistance: 25.1 Ω/km at 20°C.
Special Flat Cable (OMRON SCA1-4F10, 100 m)	Four 0.75 mm ² conductors (2 signal wires and 2 power supply wires) Maximum ambient temperature: 60°C

- Note**
1. Do not use cables other than those specified above.
 2. For information on communications cables specified by overseas manufacturers, refer to *Appendix Standard Models*.

The communications distance depends on the cable used, as follows:

Cable	Mode	Main line length	Branch line length	Total branch line length
2-conductor VCTF cable	High-speed Communications Mode	100 m max.	3 m max.	50 m max.
	Long-distance Communications Mode	500 m max.	6 m max.	120 m max.
4-conductor VCTF cable	High-speed Communications Mode	30 m max. (See note.)	3 m max. (See note.)	30 m max. (See note.)
	Long-distance Communications Mode	Flexibly branched, provided that the total length of cable is a maximum of 200 m.		
Special Flat Cable	High-speed Communications Mode	30 m max. (See note.)	3 m max. (See note.)	30 m max. (See note.)
	Long-distance Communications Mode	Flexibly branched, provided that the total length of cable is a maximum of 200 m.		

Note When 4-conductor VCTF cable or Special Flat Cable is used to connect fewer than 16 Slaves, the main line can be up to 100 m long and the total branch line length can be up to 50 m in High-speed Communications Mode. (These are the same conditions as when 2-conductor VCTF cable is used.)

1-3-4 Connectors/Terminal Blocks

The following table lists the connectors that can be used in a CompoBus/S System.

Connector	Model	Comments
Branch Connector	SCN1-TH4	Use this connector to create a branch line from the main line. (Used with Special Flat Cable only.)
Extension Connector	SCN1-TH4E	Use this connector to extend the Special Flat Cable.
Connector Terminator	SCN1-TH4T	This connector has a built-in terminator. (Used with Special Flat Cable only.)
Connectors with Cable with a socket and plug	XS2W-D42□-□81-□	Connectors with cable used to connect the Water-resistant Terminal to a T-joint. Can be used as a power supply cable (with the female socket connected to the Water-resistant Terminal). Can be used as an I/O cable for sensors that have connectors (with the male plug connected to the Water-resistant Terminal, if the product has a model number suffix "A").
Connector with Cable with a female socket	XS2F-D42□-□80-□	A connector with cable used to connect the Water-resistant Terminal to a T-branch connector. Can be used as a power supply cable (with the female socket connected to the Water-resistant Terminal) and the other end wired to a commercially available terminal block.
Connector with Cable with a male plug	XS2H-D421-□80-A	A connector with a cable used to connect the Water-resistant Terminal to an I/O device. Can be used as an I/O cable (with the male plug connected to the Water-resistant Terminal) and the other end wired to the I/O device.

Connector	Model	Comments
Connector Socket Assembly (female for screw, crimp, solder terminals)	XS2C-D4S7	A connector used to connect to the communications connector or external power supply connector of the Water-resistant Terminal or a T-joint plug. Applicable cable dia.: 6 to 8 mm Applicable conductor size: 0.18 to 0.75 mm ²
	XS2C-D4□□	A connector used to connect to the external power supply connector of the Water-resistant Terminal or a T-joint plug. Applicable cable dia.: 3 to 6 mm Applicable conductor size: 0.18 to 0.3 or 0.5 to 0.75 mm ²
Connector Plug Assembly (male for screw, crimp, solder terminals)	XS2G-D4S7	A connector used to connect to the T-joint socket. Applicable cable dia.: 6 to 8 mm Applicable conductor size: 0.18 to 0.75 mm ²
	XS2G-D4□□	A connector used to connect to the I/O connector of the Water-resistant Terminal or a T-joint socket. Applicable cable dia.: 3 to 6 mm Applicable conductor size: 0.18 to 0.3 or 0.5 to 0.75 mm ²
T-joint	XS2R-D427-5	A joint used to T-branch a VCTF cable (e.g., a communications cable or power supply cable).
Communications Connector (6 pins)	FK-MCP1.5/6-STF-3.81	A communications connector for connecting CJ-series Master Units. The connector can be connected simultaneously to the communications cable (BD H, BD L, BS+, BS-) and communications power supply (BS+, BS-). This connector has screwless terminals for signal lines and connector lock screws.
	MC1.5/6-STF-3.81	A communications connector for connecting CJ-series Master Units. The connector can be connected simultaneously to the communications cable (BD H, BD L, BS+, BS-) and communications power supply (BS+, BS-). This connector has screw terminals for signal lines and connector lock screws.
Shielded Terminator Plug (Male)	SRS2-1	A shielded connector terminator model connected to a T-joint.
Terminal-block Terminator	SRS1-T	This terminal block has a built-in terminator. (Can be used with VCTF cable and Special Flat Cable.)

- Note**
1. Connect a terminator (Connector Terminator, Shield Terminator, or Terminal-block Terminator) to the following point in the system.
 - System with Distinction between Main and Branch Lines: The end of the main line farthest from the Master.
 - System with No Distinction Main and Branch Lines: The end of the communications cable farthest from the Master.
 2. Use a commercially available terminal block or T-joint to branch or extend VCTF cable.

Dimensions

The following diagram shows the dimensions (after assembly). All dimensions are in mm.

SCN1-TH4 Branch Connector

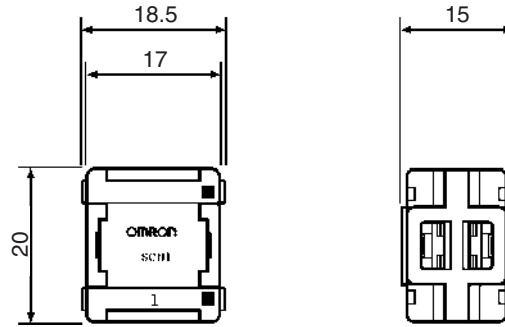

SCN1-TH4E Extension Connector

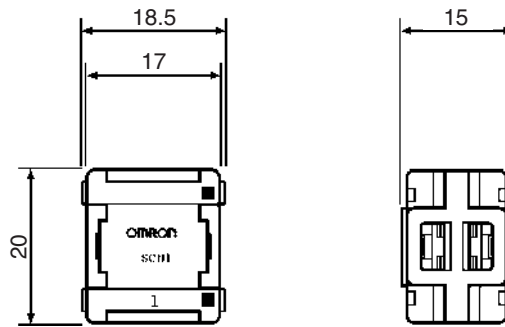

SCN1-TH4T Connector Terminator

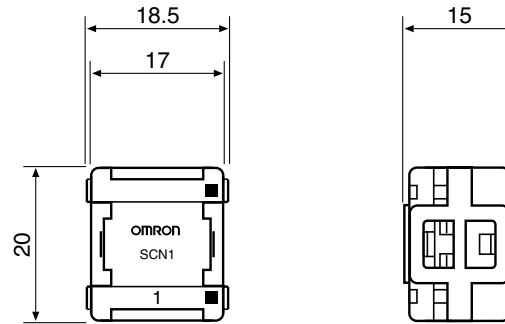

Connectors with Cables

XS2W-D42□-□81-□ (socket and plug)



XS2F-D42□-□80-□ (socket on one end)

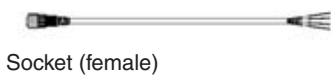

XS2H-D421-□80-A (plug on one end)



Connector Assembly

Socket (Female)
 (Crimp terminals/Solder terminals)
 XS2C-D4S7 (Communications)
 XS2C-D4□□ (Power supply and I/O)

Plug (Male)
 (Crimp terminals/Solder terminals)
 XS2G-D4S7 (Communications)
 XS2G-D4□□ (Power supply and I/O)



XS2R-D427-5 T-joint

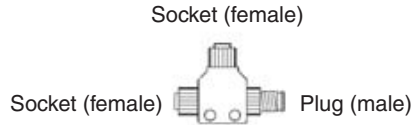

SRS2-1 Shield Terminator Plug (male)



SRS1-T Terminal-block Terminator

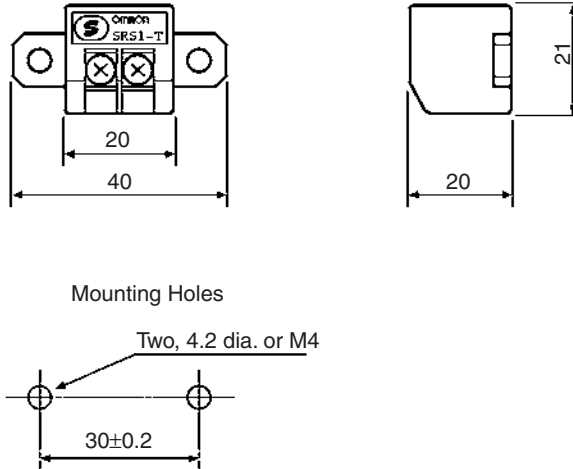

1-4 Startup Procedure

The standard procedure for starting up the CompoBus/S System is as follows:

Selecting Master and Slave

Select the Master and Slaves according to the following items.

- PLC model being used (Refer to 1-3-1 *Compatible Masters* and SECTION 4 *Master Unit Specifications and Operations*.)
- Number of Slaves (Refer to 1-3-1 *Compatible Masters*)
- Maximum I/O points (Refer to 1-3-1 *Compatible Masters*)
- Slave I/O types (Refer to 1-3-2 *Slave Units* and SECTION 5 *Slave Specifications and Operations*)

Determining the Communications Mode

Determine the communications mode according to the following items.

- Communications distance (Refer to 2-2-2 *Maximum Cable Length*)
- I/O response time (Refer to 2-5 *I/O Response Time Characteristics*)

Determining System Configuration

Determine the CompoBus/S System configuration according to the following items. Select the devices required for connection (such as connectors, terminal blocks, and terminators) according to the system configuration.

- Arrangement of Master and Slaves (Refer to page 8 and page 25.)
- Cable types applicable for the communications distance and communications mode (Refer to page 16 and page 29.)
- Connection methods (Refer to page 8 and page 27.)
- Methods for supplying communications and I/O power supplies (Refer to page 31.)
- Connectors and terminal block models (Refer to page 6 and page 27.)

Setting the Master Unit

Set the Master Unit according to the model used, referring to *SECTION 4 Master Unit Specifications and Operations*.

CS-series, C200HX/HG/HE-(Z)E, and C200HS Master Units (C200HW-SRM21-V1)

- Special I/O Unit unit number
- Number of nodes that can be connected
- Communications mode

CS-series Master Units (CS1W-SRM21)

- Special I/O Unit unit number
- Number of nodes that can be connected
- Communications mode
- Slave registration function (Set in DM Area while connected to the PLC.)
- Communications stop mode setting function

CJ-series Master Units

- Special I/O Unit unit number
- Number of nodes that can be connected
- Communications mode
- Slave registration function (Set in DM Area while connected to the PLC.)
- Communications stop mode setting function

CQM1 Master Units

- Number of words allocated to the CPU
- Number of bits allocated for each node number
- Communications mode

Setting the Slaves

Set the Slave Units, referring to *SECTION 5 Slave Specifications and Operations*.

- Node number
- Communications mode
- Settings specific to each Slave (such as output holding/clearing when communications errors occur)

Wiring

Wire and connect the communications cables, communications power supply, I/O power supply, referring to the device specifications in *SECTION 4 Master Unit Specifications and Operations*, *SECTION 5 Slave Specifications and Operations*, and wiring information in *SECTION 3 CompoBus/S System Wiring*.

Starting and Checking Operations

Start the CompoBus/S System and check the Master and Slave operations, referring to *SECTION 6 Starting Communications*.

Starting Operations

Start operating the Master and Slaves.

SECTION 2

CompoBus/S System Specifications and Configuration

This section provides information on CompoBus/S System specifications, methods used to configure a CompoBus/S System, and I/O response times.

2-1	Communications Specifications	24
2-2	System Configuration	25
2-2-1	Main Line/Branch Line Connections	25
2-2-2	Maximum Cable Length	29
2-2-3	Terminator Connection	31
2-3	Supplying Power to the Slaves	31
2-3-1	Using 2-conductor VCTF Cable	33
2-3-2	Using 4-conductor VCTF or Special Flat Cable	34
2-3-3	Limitations of Communications Cable Power Supply	35
2-4	System Configuration Using Water-resistant Terminals	41
2-5	I/O Response Time Characteristics	41
2-5-1	Slaves Other Than Analog Terminals	42
2-5-2	Slave Analog Terminals	46
2-5-3	Slave I/O Delay Times	51

2-1 Communications Specifications

This section provides specifications for the CompoBus/S System.

Item		Specification
Communications method		Special CompoBus/S protocol
Communications baud rate		High-speed Communications Mode: 750 kbps Long-distance Communications Mode: 93.75 kbps
Modulation method		Baseband method
Coding method		Manchester coding method
Error control checks		Manchester code check, frame length check, and parity check
Cable	VCTF cable (JIS C 3306)	Two 0.75 mm ² conductors (2 signal wires) Four 0.75 mm ² conductors (2 signal wires and 2 power supply wires)
	Special Flat Cable	Four 0.75 mm ² conductors (2 signal wires and 2 power supply wires)
Communications distance	2-conductor VCTF cable	High-speed Communications Mode Main line length: 100 m max. Branch line length: 3 m max. Total branch line length: 50 m max.
		Long-distance Communications Mode Main line length: 500 m max. Branch line length: 6 m max. Total branch line length: 120 m max.
	4-conductor VCTF cable	High-speed Communications Mode Main line length: 30 m max. Branch line length: 3 m max. Total branch line length: 30 m max.
		Long-distance Communications Mode: Flexibly branched, provided that the total length of cable is a maximum of 200 m.
	Special Flat Cable	High-speed Communications Mode Main line length: 30 m max. Branch line length: 3 m max. Total branch line length: 30 m max. When 4-conductor VCTF cable or Special Flat Cable is used to connect fewer than 16 Slaves, the main line can be up to 100 m long and the total branch line length can be up to 50 m in High-speed Communications Mode.
		Long-distance Communications Mode: Flexibly branched, provided that the total length of cable is a maximum of 200 m.

Restrictions on Connections

The following restrictions apply to CompoBus/S connections:

System with Distinction between Main and Branch Lines

The following diagram shows a CompoBus/S System configuration in which the main line must be distinguished from the branch lines under either of the following conditions.

- The system operates in High-speed Communications Mode.
- The system operates in Long-distance Communications Mode with 2-conductor VCTF cable.

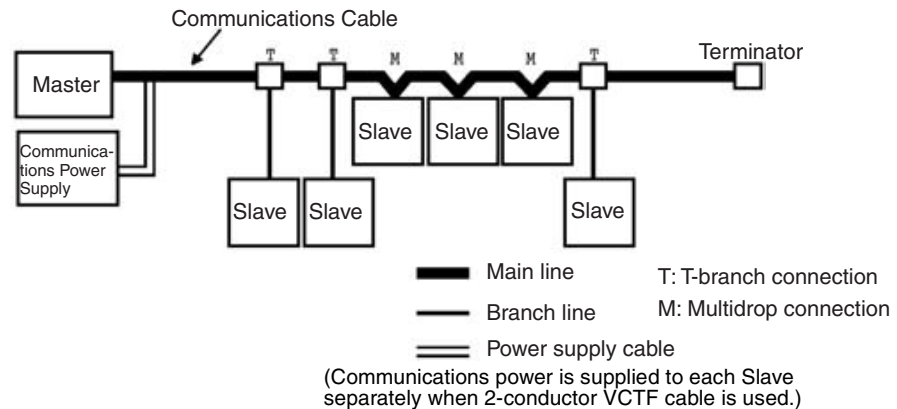

- The main line is the cable that connects the ends of the system. The maximum length of the main line depends on the communications mode, the type of cable, and the number of Slaves being used. Refer to *2-2-2 Maximum Cable Length* for details.
- A branch line is any cable that branches off the main line. The maximum length of a single branch line and the maximum total length of all branch lines in a CompoBus/S system vary according to the communications mode, the types of cables used, and the number of Slaves. Refer to *2-2-2 Maximum Cable Length* for details.
- The Master must be connected at one end of the main cable and the terminator must be connected at the other end. The Master cannot be connected at a point along the main line or on a branch line.
- Only one Master can be connected in the CompoBus/S System. The range of usable node numbers that can be connected depends on the model of Master being used and its settings. Refer to *2-1 Communications Specifications* for details.
- Only one Slave can be connected to each branch line. It is not possible to branch again from a branch line.
- There are three types of cable that can be used (2-conductor VCTF cable, 4-conductor VCTF, and Special Flat Cable), but it is not possible to use more than one type of cable in the same CompoBus/S System.

System with No Distinction between Main and Branch Lines

The following diagram shows a CompoBus/S System configuration in which no distinction is required between the main line and the branch lines under either of the following conditions.

- The system operates in Long-distance Communications Mode with 4-conductor VCTF cable
- The system operates in Long-distance Communications Mode with Special Flat Cable

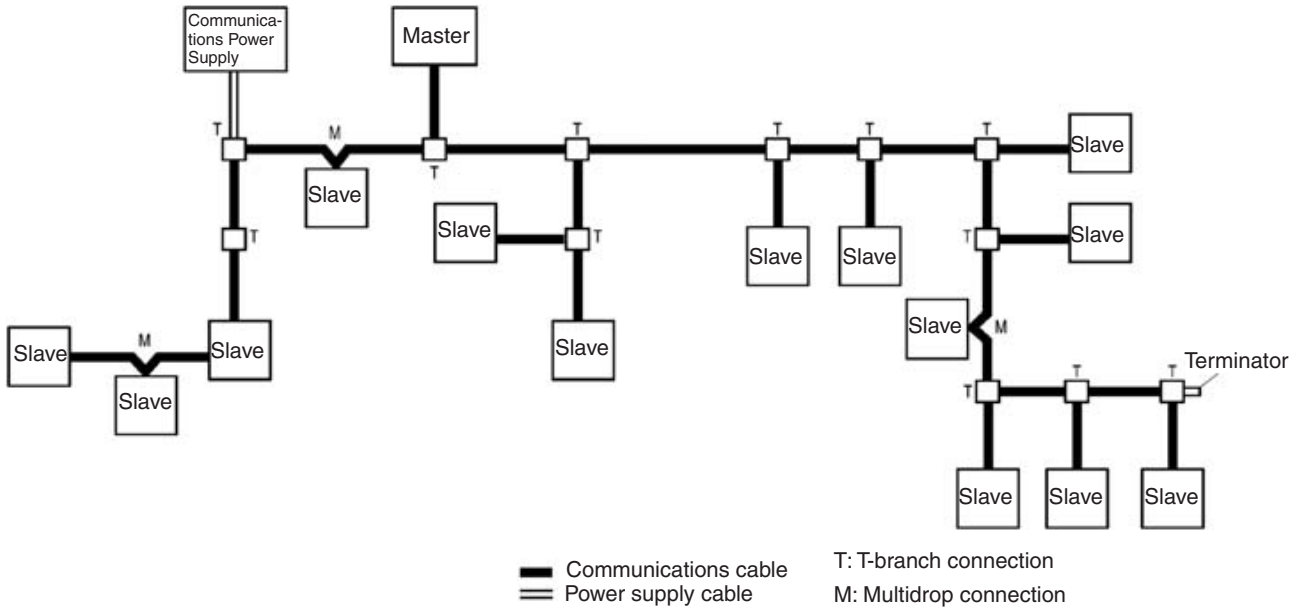

- When the system operates in Long-distance Communications Mode with Special Flat Cable or 4-conductor VCTF cable used, there will be no need to distinguish main and branch lines for the system. It is not, however, possible to use more than one type of cable in the same CompoBus/S system.
- The maximum length of cable used for the CompoBus/S system is 200 m regardless of the type of communications cable.
- Only a single terminator farthest from the Master is required regardless of the position the Master is connected to the communications cable.
- More than a single Master cannot be connected to the CompoBus/S System. The possible range of node numbers varies with the type of Master and settings in the Master. Refer to 2-1 Communications Specifications Specifications for details.

Connection Methods

The Master and Slaves can be connected by either the T-branch method or the multidrop method.

T-branch Method

In the T-branch method, a branch connector, a commercially available terminal block, or a T-joint is used to create a branch from the main line and connect a Slave when the main line is distinguished from branch lines. The maximum length of the branch line varies according to the communications mode and the type of cable used. For details, refer to 2-2-2 Maximum Cable Length. A secondary branch cannot be connected to the branch line when the main line is distinguished from branch lines.

System with Distinction between Main and Branch Lines

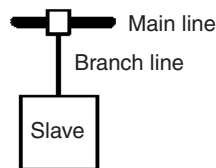

System with No Distinction between Main and Branch Lines

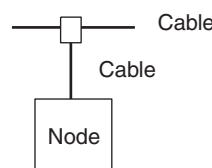

The actual wiring for T-branch connections is given next.

1,2,3... 1. **Branch Connector**

When using Special Flat Cable, connect a Branch Connector to the main line to create a branch, as shown in the following diagram.

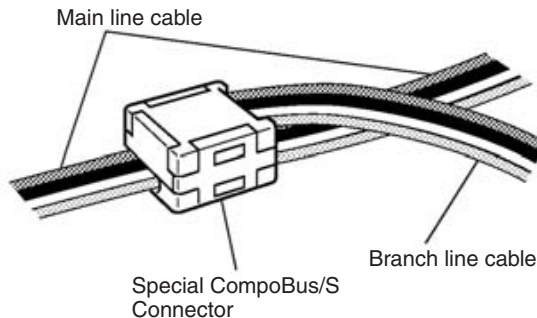

2. **Terminal Block Connector**

A commercially available relay terminal block (a terminal block in which the opposite terminals are connected) can be used to create a branch line, as shown in the following diagram.

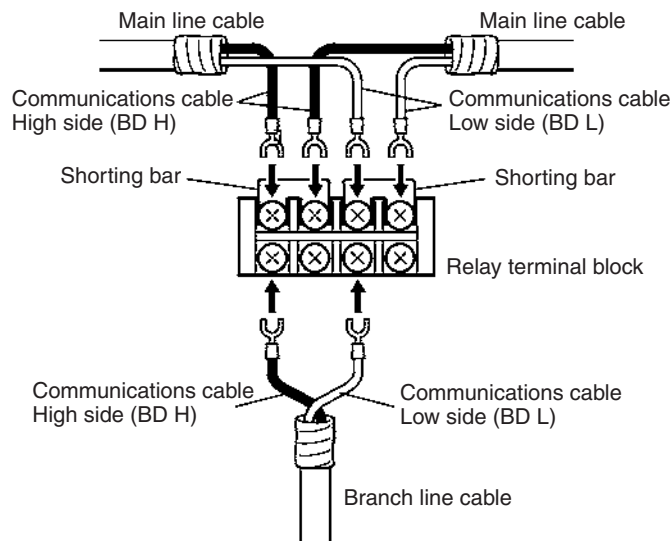

3. **T-joint**

When 4-conductor VCTF cable is used, use a T-joint to branch the line as shown below.

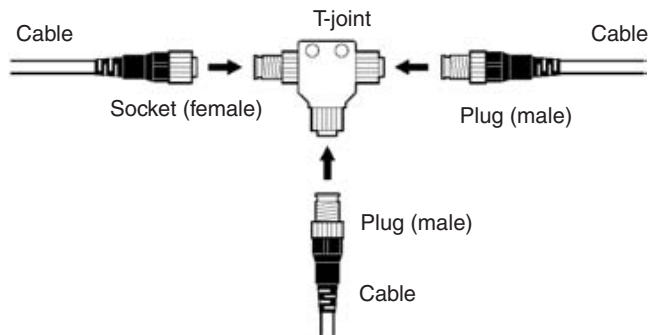

Multidrop Method

In the multidrop method, nodes are connected directly to the cable. It is not necessary to create a new branch line or use special connectors with the mul-

tidrop method. When the main line is distinguished from branch lines, Slaves must be connected to the main line.

System with Distinction between Main and Branch Lines **System with No Distinction between Main and Branch Lines**



The actual wiring for multidrop connections is shown in the following diagram. The Slave is connected to the signal wires from the Master side of the system as well as the signal wires from the terminator side of the system.

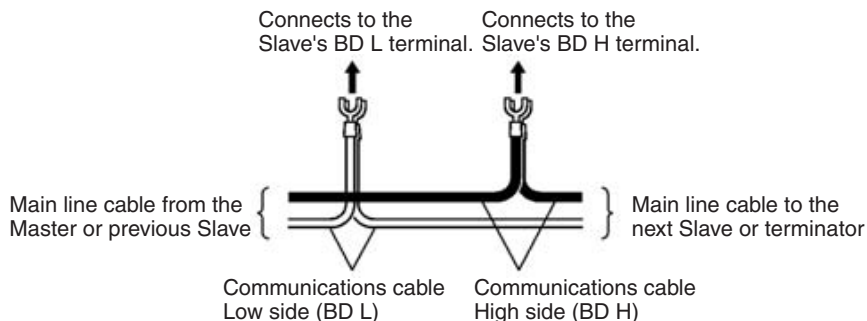

2-2-2 Maximum Cable Length

The main line length is the total length of the cable connecting the Master and the terminator at the farthest end of the system. The branch line length is the length of a cable connecting a Slave to the main line and the total branch line length is the sum of lengths of all of the branch lines in the system.

When the system has no main line distinguished from the branch lines, the communications cable can be connected with no particular restrictions, provided that the total length of communications cable is a maximum of 200 m.

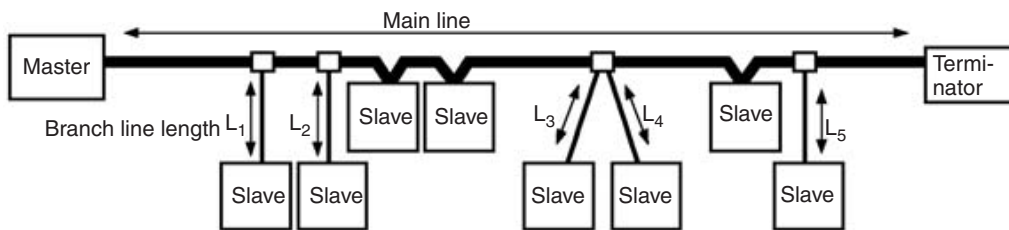

Total branch line length = $L_1 + L_2 + L_3 + L_4 + L_5$

The maximum main line, branch line, total branch line, and total cable lengths depend on the type of cable and number of Slaves being used, as shown in the following table.

Communication mode	Cable type	Cable length		
		Main line	Branch line	Total of branch lines
High-speed Communications Mode	2-conductor VCTF cable	100 m max.	3 m max.	50 m max.
	4-conductor VCTF cable	30 m max. (See note.)	3 m max.	30 m max. (See note.)
	Flat	30 m max. (See note.)	3 m max.	30 m max. (See note.)

Communication mode	Cable type	Cable length		
		Main line	Branch line	Total of branch lines
Long-distance Communications Mode	2-conductor VCTF cable	500 m max.	6 m max.	120 m max.
	4-conductor VCTF cable	Total length of communications cable: 200 m max. (with no distinction between main and branch lines)		
	Flat	Total length of communications cable: 200 m max. (with no distinction between main and branch lines)		

Note If the number of connected Slaves does not exceed 16 when using the High-speed Communications Mode, the main line length can be up to 100 m and the total branch line length can be up to 50 m (i.e., the same as for the VCTF cable). An example is given below.

Refer to the following examples.

• Example 1

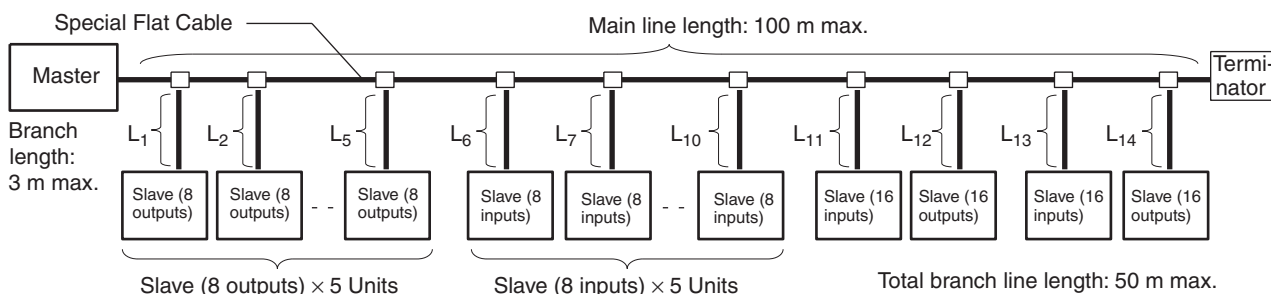

No. of Slave Units	8-input Slave × 5 Units + 8-output Slave × 5 Units + 16-input Slave × 2 Units + 16-output Slave × 2 Units = 14 Slave Units
Number of I/O points	72 inputs and 72 outputs

• Example 2

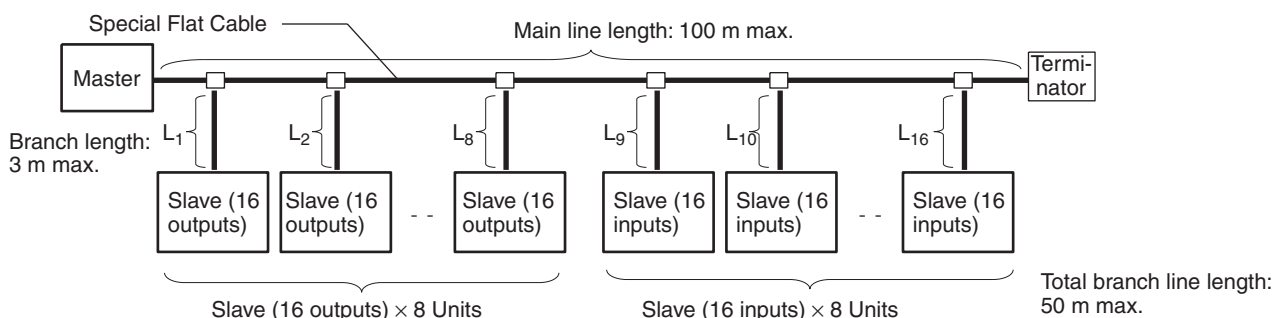

No. of Slave Units	16-input Slave × 8 Units + 16-output Slave × 8 Units = 16 Slave Units
Number of I/O points	128 inputs and 128 outputs

Do not mix 2-conductor VCTF, 4-conductor VCTF, and Special Flat Cables in the same system.

Refer to the *Appendix Standard Models* for details on compatible communications cables.

Note When 4-conductor VCTF or Special Flat Cable is used to supply the Slave's communications power, the length of the cable may be limited by current and voltage drops in the cable and connectors. Refer to *2-3-3 Limitations of Communications Cable Power Supply* on page 35 for details.

2-2-3 Terminator Connection

System with Distinction between Main and Branch Lines

A terminator must be connected to the end of the main line opposite the Master (the farthest end of the cable) in order to stabilize communications. When the last Slave in the system is connected to the main line by a T-branch connector, make sure that the terminator is farther from that T-connection than the Slave so that the terminator is farther from the Master.

The following diagram shows the connections in a typical CompoBus/S System with distinguished main and branch lines. The power supply system has been omitted.

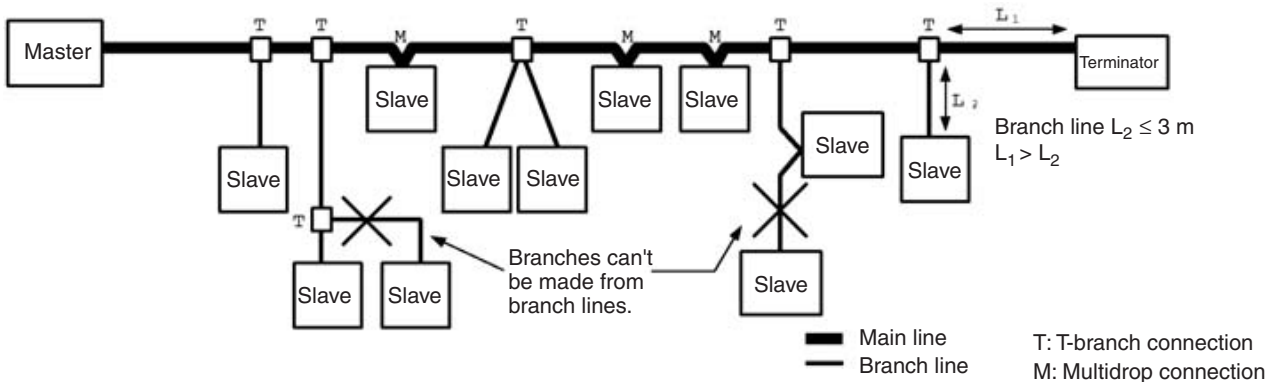

System with No Distinction between Main and Branch Lines

A terminator must be connected to the end of the communications cable farthest from the Master in order to stabilize communications. When the last Slave in the system is connected to the communications cable by a T-branch connector, extend the cable to connect the terminator or connect the terminator at the T-branching position. The cable distance to the terminator includes the total cable length.

2-3 Supplying Power to the Slaves

The Slaves must be supplied with power for communications and some Slaves must have a separate power supply for I/O. The methods for supplying power to the Slaves depend on the type of communications cable being used.

Slave power supply	Usage	2-conductor VCTF cable	4-conductor VCTF cable Special Flat Cable
Network power supply	1 For both communications and I/O	External power supply (collective supply possible)	Power supplied via 4-conductor VCTF cable, Special Flat Cable, or from external power source
Multiple power supply	2 For communications	External power supply (collective supply possible)	Power supplied via 4-conductor VCTF cable, Special Flat Cable, or from external power source
	For I/O	External power supply (collective supply impossible)	External power source
Local power supply	1 For both communications and I/O	External power supply (collective supply impossible)	External power source

The following table groups the Slaves according to their power supply requirements.

Power supply	Slave type	Model numbers	
Network power supply	Sensor Terminals	SRT1/SRT2-ID08S SRT1/SRT2-ND08S	
	Fiber Amplifier Communications Unit	E3X-SRT21	
	Analog I/O Terminals	SRT2-AD04 SRT2-DA02	
Multiple power supplies	Remote Terminals with Transistors	SRT1/SRT2-ID04	SRT1/SRT2-ID16T
		SRT1/SRT2-ID04-1	SRT1/SRT2-ID16T-1
		SRT1/SRT2-ID08	SRT1/SRT2-OD16T
		SRT1/SRT2-ID08-1	SRT1/SRT2-OD16T-1
		SRT1/SRT2-ID16	SRT1/SRT2-MD16T
		SRT1/SRT2-ID16-1	SRT1/SRT2-MD16T-1
SRT1/SRT2-OD04			
SRT1/SRT2-OD04-1			
SRT1/SRT2-OD08			
SRT1/SRT2-OD08-1			
SRT1/SRT2-OD16			
SRT1/SRT2-OD16-1			
Connector Terminals with Transistors	SRT2-VID08S	SRT2-OD32ML	
	SRT2-VID08S-1	SRT2-OD32ML-1	
	SRT2-VID16ML	SRT2-MD32ML	
	SRT2-VID16ML-1	SRT2-MD32ML-1	
	SRT2-ID32ML		
	SRT2-ID32ML-1		
	SRT2-VOD08S		
	SRT2-VOD08S-1		
	SRT2-VOD16ML		
	SRT2-VOD16ML-1		
Water-resistant Terminals with Transistors	SRT2-ID04CL	SRT2-OD04CL	
	SRT2-ID04CL-1	SRT2-OD04CL-1	
	SRT2-ID08CL	SRT2-OD08CL	
	SRT2-ID08CL-1	SRT2-OD08CL-1	
Local power supply	Sensor Terminals with Connector Outputs	SRT1/SRT2-OD08S	
	Remote Terminals with Relays	SRT1/SRT2-ROC08 SRT1/SRT2-ROC16	
	Remote Terminals with Power MOS FETs	SRT1/SRT2-ROF08 SRT1/SRT2-ROF16	
---	Remote I/O Modules	SRT1/SRT2-ID16P SRT1/SRT2-OD16P	
---	CPM1A/CPM2A I/O Link Unit	CPM1A-SRT21	
---	CPM2C I/O Link Unit	CPM2C-SRT21	

Communications Power Supply

OMRON's S82-series Power Supplies are recommended for supplying power to the Slaves for communications. Select a power supply with a current capacity greater than the total power consumed by all of the Slaves that will be connected.

Note Be sure to provide a power supply with a current capacity sufficient to handle the surge current that flows at startup.

2-3-1 Using 2-conductor VCTF Cable

Power cannot be supplied to the Slaves through 2-conductor VCTF cable. When a CompoBus/S System is being constructed with 2-conductor VCTF cable, each Slave must be supplied with power along a route separated from the VCTF cable. Furthermore, an I/O power supply must be provided for Slaves that require an I/O power supply.

Independent Power Supplies

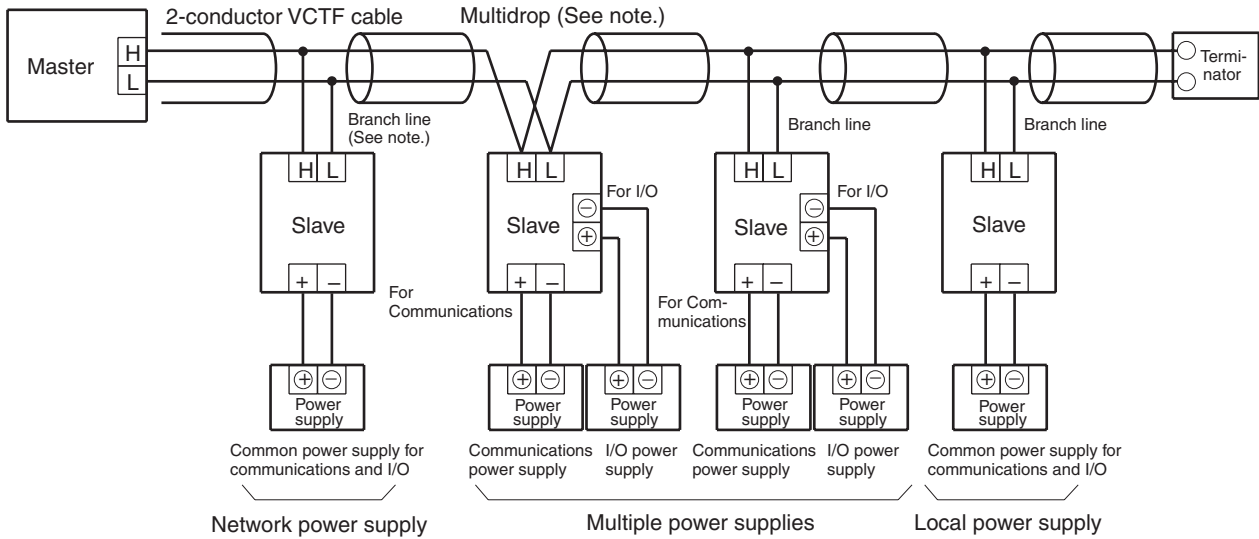

Note Both T-branch connections and multidrop connections are possible with each type of power supply.

Common Power Supply

When using a common power supply with long power lines, make sure that there isn't a significant decline in the supply voltage due to attenuation.

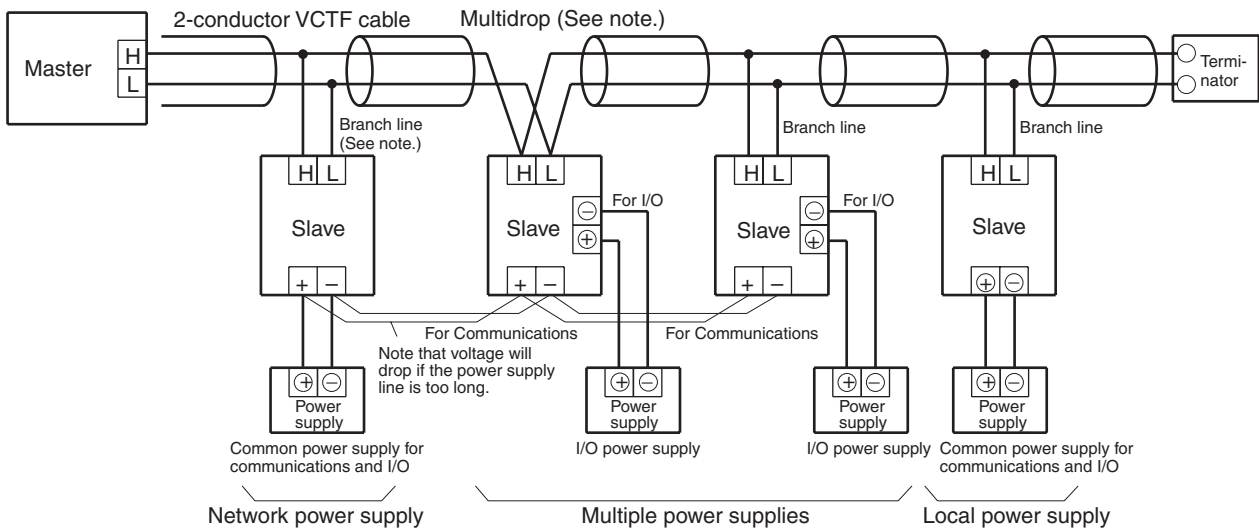

Note Both T-branch connections and multidrop connections are possible with each type of power supply.

It is possible to supply all communications power collectively via a single line. If the power supply line is too long, however, the conductor resistance of the cable will cause voltage to drop. For information concerning the allowable length of the collective power supply cable, refer to 4. *Cable Length Limit Due*

to Voltage Drop in 2-3-3 Limitations of Communications Cable Power Supply on page 37. In this case, replace the figure stated for the cable's resistance with the conductor resistance of the collective communications power supply cable in your calculations to verify the allowable cable length.

Note Depending on the loads connected, multiple power supplies for I/O may generate electrical noise. Even for a collective power supply, the I/O power supply should be separated from the communications power supply so that it does not affect other Slaves. Similarly, a local power supply used for both communications and I/O should also be kept separate from communications power supplies.

2-3-2 Using 4-conductor VCTF or Special Flat Cable

Power can be supplied to the Slaves through 4-conductor VCTF or Special Flat Cable. When a CompoBus/S System is being constructed with 4-conductor VCTF or Special Flat Cable, the method used to supply power to the Slaves depends on the type of Slave being used.

The following diagram shows an example of a CompoBus/S System connected with Special Flat Cable that uses each type of Slave. There is no difference in configuration when 4-conductor VCTF cable is used.

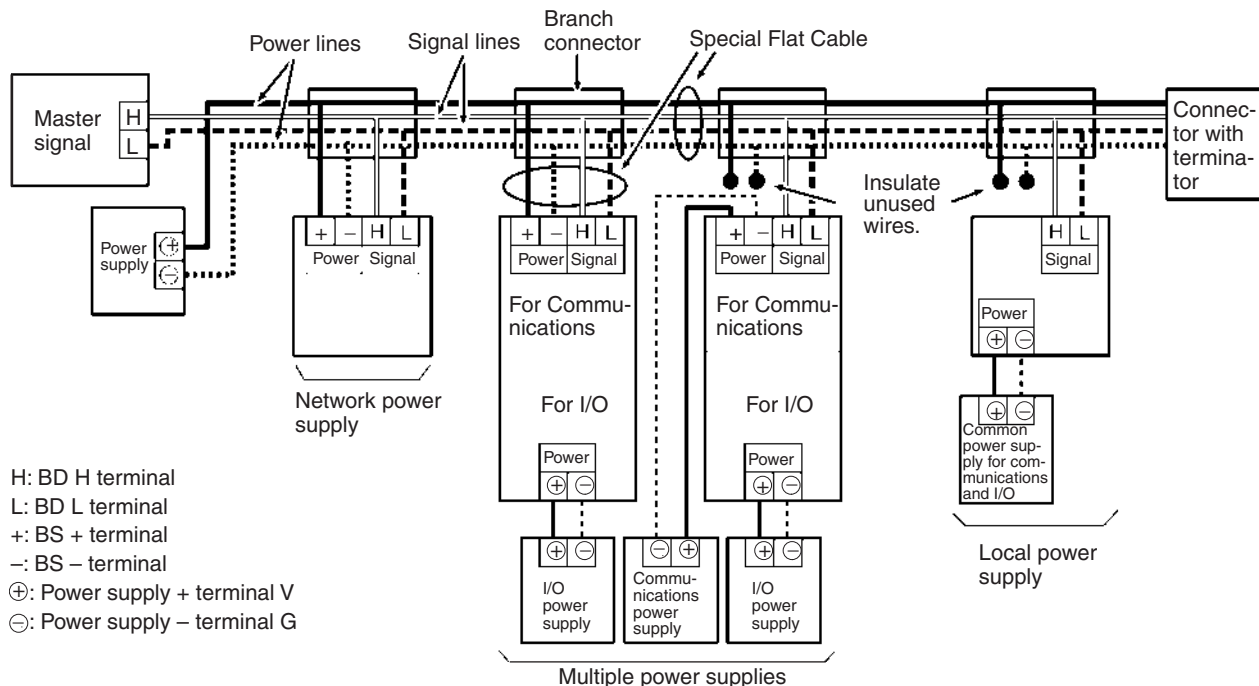

Note 1. Be sure to insulate unused Special Flat Cable wiring when using a Slave that requires a local power supply or using an external power supply for communications in a Slave that requires multiple power supplies.

2. If multiple CompoBus/S Systems are used, provide a separate communications power supply for each CompoBus/S System to prevent unstable operation due to unwanted noise paths in the power supplies of the CompoBus/S Systems.

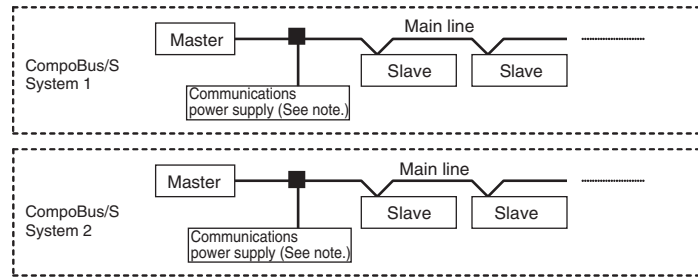

Note: Use a separate communications power supply for each line.

3. When using CJ-series Master Units, use 6-pin communications connectors that allow simultaneous connection of communications and power supply cables. Power can be supplied to the Slaves easily by connecting the communications power supply to the Master Unit without preparing the communications cables, as shown in the following diagram.

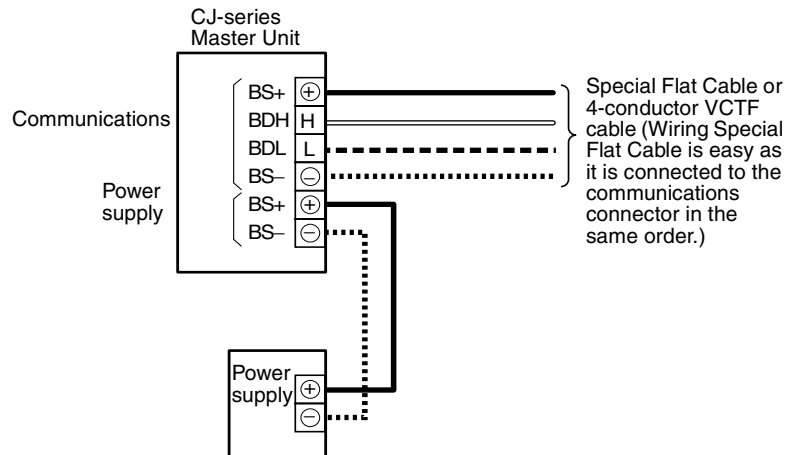

The BS+ and BS- terminals of the CJ-series Master Unit's communications connector are connected internally. (The Master Unit does not use the BS+ or BS- terminals.)

2-3-3 Limitations of Communications Cable Power Supply

Check the following points when using 4-conductor VCTF or Special Flat Cable to supply power to Slaves.

- The 4-conductor VCTF or Special Flat Cable's allowable current
 - The Extension Connector's allowable current (when using an Extension Connector)
 - The allowable current of the CJ-series Master Unit's communications connector (when using CJ-series Master Units)
 - Cable length limit due to voltage drop
1. **4-conductor VCTF or Special Flat Cable's Allowable Current**
The allowable current through the 4-conductor VCTF or Special Flat Cable depends on the ambient temperature, as shown in the following tables.

• 4-conductor VCTF Cables

Ambient temperature (°C)	0	5	10	15	20	25	30	35	40	45
Allowable current (A)	7	7	7	7	7	7	7	6	5.5	4.5

• Special Flat Cables

Ambient temperature (°C)	0	5	10	15	20	25	30	35	40	45
Allowable current (A)	13	12	11	10	8	7	6	5	4	3

The total current supplied to the Slaves must be less than the allowable current, regardless of whether the system has a main line distinguished from the branch lines or not.

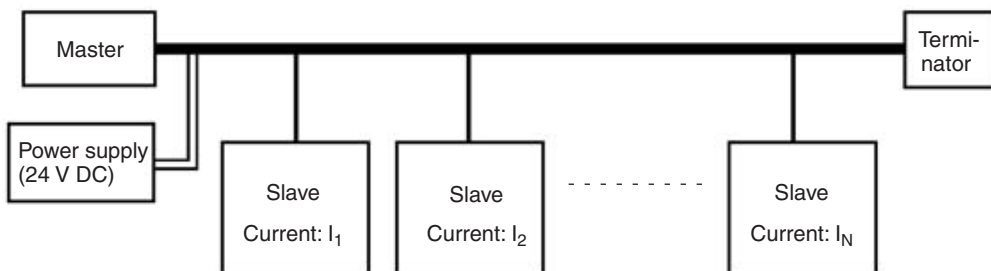

For example, at 30°C the total current consumption of the Slaves must be 6 A or less when Special Flat Cable is used.

2. Extension Connector or T-joint's Allowable Current

The allowable current through an Extension Connector is 4 A and that through a T-joint is 3 A. Therefore, the total current supplied to the Slaves beyond the Extension Connector or T-joint must be less than 4 A, regardless of whether the system has a main line distinguished from the branch lines or not.

Extension Connector

$$I_1 + I_2 + \dots + I_N \leq 4 \text{ A}$$

(I₁, I₂, I_N: current consumption of each Slave after Extension Connector)

T-joint

$$I_1 + I_2 + \dots + I_N \leq 3 \text{ A}$$

(I₁, I₂, I_N: current consumption of each Slave after the T-joint.)

Example

Extension Connector used

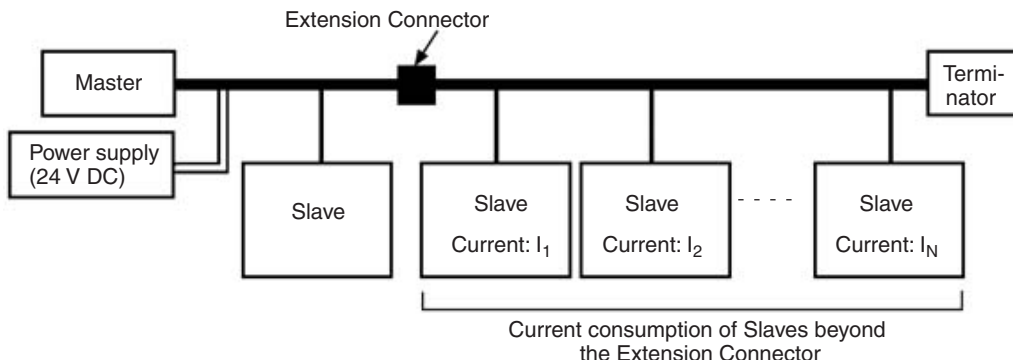

Note When a commercially available terminal block is used, be sure the current consumption is within the allowable current of the block.

3. **Allowable Current for CJ-series Communications Connector**

The allowable current for the communications connector of the CJ-series Master Unit is 4 A. The total current consumption of Slaves must be no more than 4 A when the CJ-series Master Unit communications connector is connected to the communications power supply. (The same applies when there is no distinction between main and branch lines.)

$$I_1 + I_2 + \dots + I_N \leq 4 \text{ A}$$

(I_1, I_2, \dots, I_N represents the current consumption of each Slave being supplied with communications power supply.)

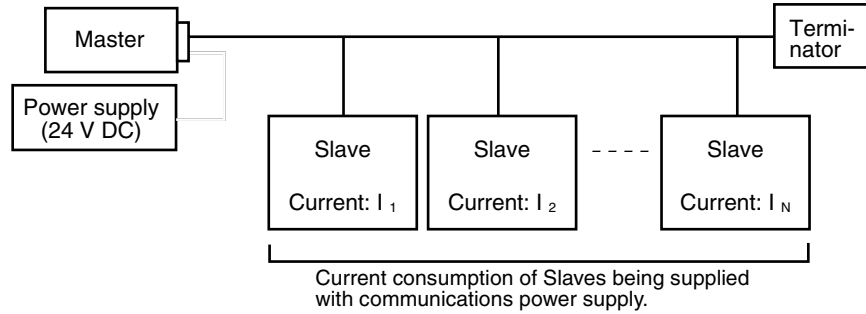

4. **Cable Length Limit Due to Voltage Drop**

The voltage drop can be calculated from the cable's length, the cable's resistance, and the Slave's current consumption. (The cable's length is multiplied by 2 because there are two wires carrying current, + and -.)

$$\text{Voltage drop (V)} = \text{Current (A)} \times (\text{Cable's length} \times 2 \times \text{Cable's resistance } (\Omega))$$

The allowable voltage range for the Slaves is 14 to 26.4 V DC, so the maximum voltage drop is 10 V DC when using a 24-V DC power supply.

The equation yielding the voltage drop for the following system is shown below. This is an approximate equation allowing some margin for error.

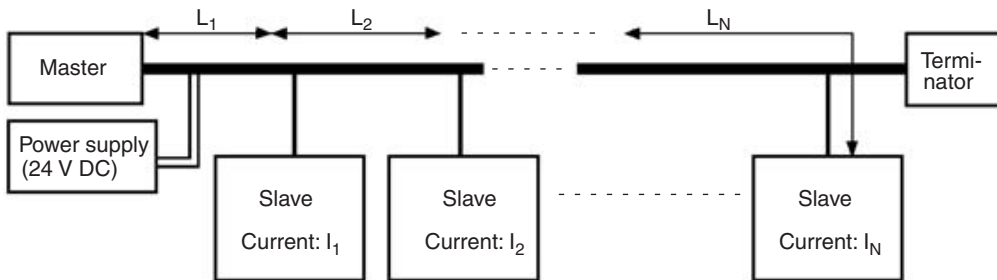

$$10 \geq (I_1 + I_2 + \dots + I_N) \times L \times 2 \times R$$

10: Max. voltage drop (V)

R: Resistance of the Special Flat Cable (Ω/m)

4-conductor VCTF cable: 0.025

Special Flat Cable: 0.027

$L_1 + L_2 + \dots + L_N$: Length of cable between the Slaves

The maximum cable length (L) can be calculated from this equation as follows:

$$L \leq 10 / \{ (I_1 + I_2 + \dots + I_N) \times 2 \times R \}$$

↓

$$L \leq 200 / (I_1 + I_2 + \dots + I_N) \dots \text{4-conductor VCTF cable}$$

$$185 / (I_1 + I_2 + \dots + I_N) \dots \text{Special Flat Cable}$$

L is the length of cable to the last Slave ($L_1 + L_2 + \dots + L_N$).
 $I_1 + I_2 + \dots + I_N$: Current consumption of each Slave (A)

- Note**
1. The allowable voltage range for a Sensor Terminal which has a 2-wired method Proximity Switch connected is 20.4 to 26.4 V DC. If the Special Flat Cable's voltage is below 20.4 V DC, use an external power supply for the Sensor Terminal.
 2. When there is no distinction between main and branch lines, substitute the cable length between the communications power supply and the farthest end for L in the above formula. If the communications power supply is at the midway point in the cable path, the cable length on the left-hand side added with that on the right-hand side will be the maximum length of the communications cable. If only some Slaves are located far from the Master, the maximum cable length calculated from the cable length to the last Slave may be very short. In such cases, calculate the voltage drop at each branching position and Slave position and design the system with an appropriate margin so that the voltage applied to each Slave will be high enough.

Example

Communications cable: Special Flat Cable

In this example a single power supply can't provide power to all of the Slaves, so the Slaves are divided into 2 groups and supplied by 2 power supplies.

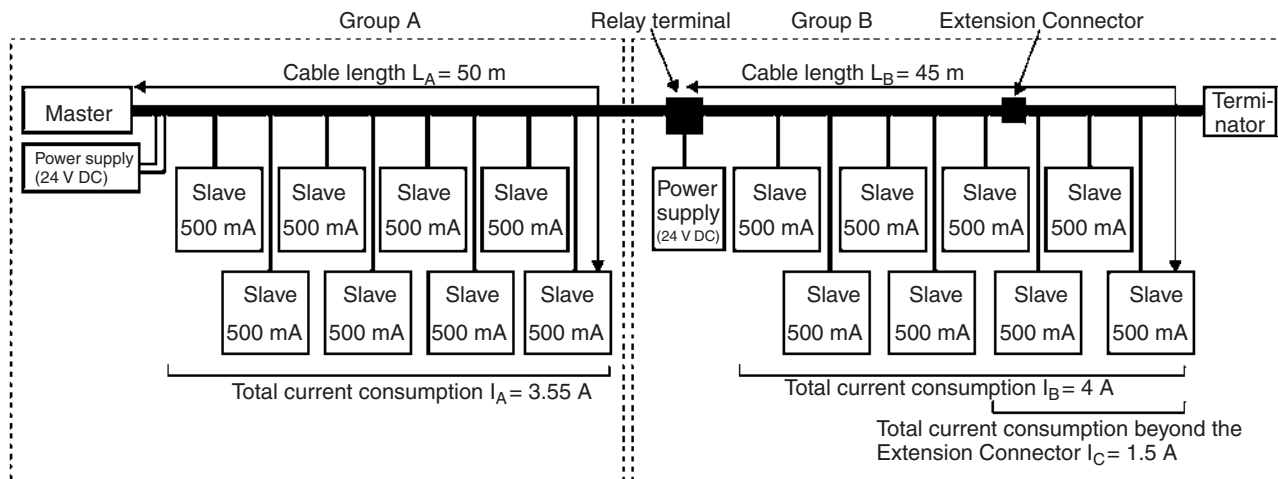

Check that each group meets the current consumption conditions. In this case the ambient temperature is 30°C.

• **Group A**

Special Flat Cable's Allowable Current: $6\text{ A} \geq 3.55\text{ A} (I_A)$

Cable Length Limit due to Voltage Drop: $185/3.55 = 52\text{ m} \geq 50\text{ m} (L_A)$

• **Group B**

Special Flat Cable's Allowable Current: $6\text{ A} \geq 4\text{ A} (I_B)$

Extension Connector's Allowable Current: $4.5\text{ A} \geq 1.5\text{ A} (I_C)$

Cable Length Limit due to Voltage Drop: $185/4 = 46\text{ m} \geq 45\text{ m} (L_B)$

When dividing the Slaves into groups to supply power, connect the groups using a standard relay terminal like the one shown in the following diagram.

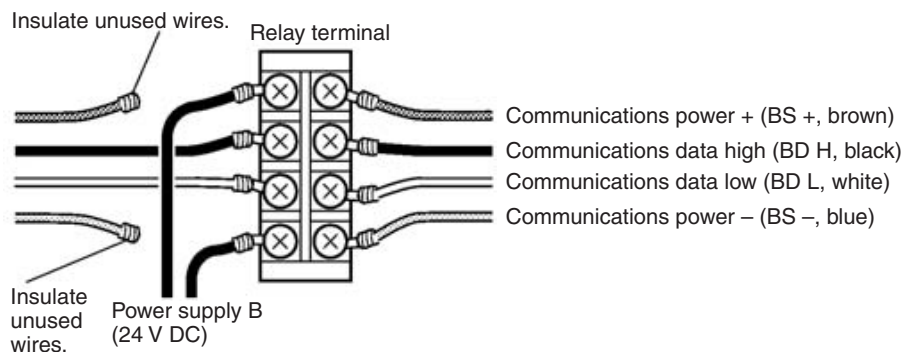

Voltage Drops Due to Wiring

When components such as circuit protectors, contactors, connectors, and fuses are incorporated in the wiring, the internal resistance and contact resistance of these components can have an effect on voltage drops as well as the conductor resistance of the cable itself. When designing the wiring, attention must be paid to these resistance values as well.

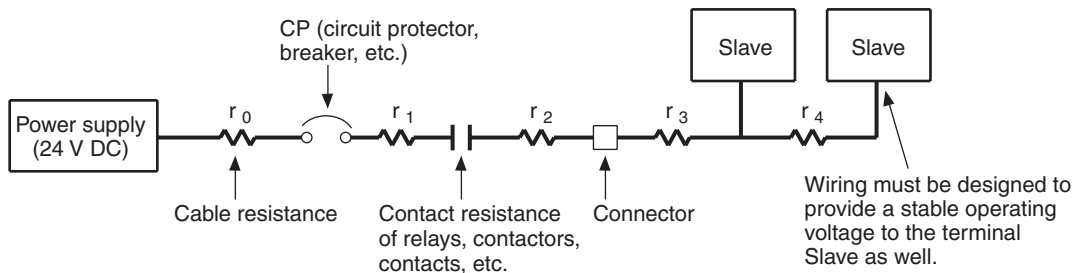

Note The resistance and allowable current varies according to the cross section, material, and structure of the cable, as well as the ambient temperature. When designing the wiring and selecting the cables to be used, refer to the specifications stated by the cable manufacturer.

Arrangement of Power Supplies

In systems in which the I/O power supply for the entire system is supplied, it is necessary to take into account the power consumption of each device and load. Cables selected for use with the terminal Slave or load should also keep voltage fluctuations within the allowable range. Care must also be taken to ensure that the total current on the lines is within the range of the permissible current of the cable, and that the capacity of the power supply is adequate.

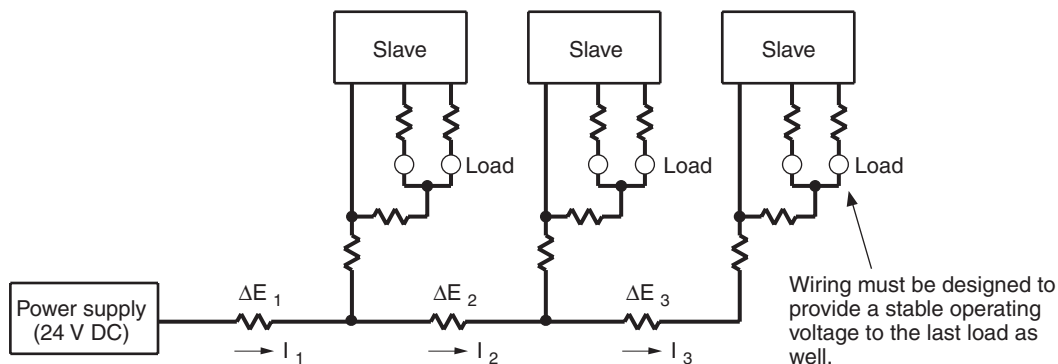

Examine the following points when deciding whether to supply I/O power for the entire system from a single source, or to install multiple power supplies.

1,2,3... 1. **Supplying I/O Power for Slaves from Multiple Power Supplies**

Supplying I/O power from several sources rather than from a single source enables line current to be reduced, and reduces voltage drops.

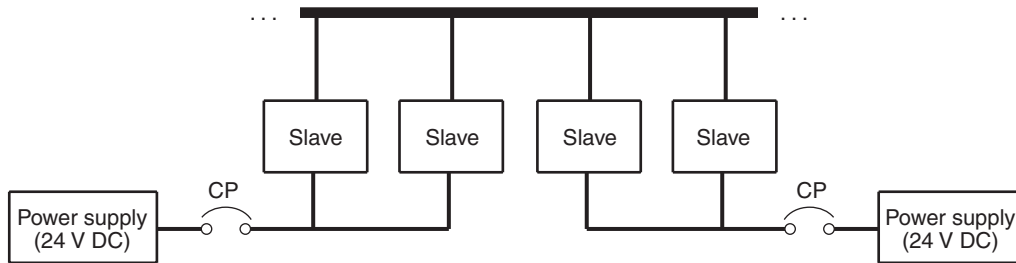

2. **Supplying Power from Single Unit**

Use the following methods for keeping voltage drops within allowable range when power is supplied from a single source.

- Increase cable thickness.
- Raise output voltage of power supply slightly.
- Shorten wiring distances.

3. **Considerations Relating to Power Supply Malfunctions**

It is necessary to examine system operation in the event of a power supply malfunction.

Example:

- a) Design the system to halt operation of all loads in the event of a single power supply failure.
- b) Design the system to prevent all loads stopping operation by installing more than one power supply.

4. **Cost Considerations**

It is also necessary to examine the costs associated with I/O power supply installation, such as the number of power supplies, cable thickness, cable length, and the labor required.

2-4 System Configuration Using Water-resistant Terminals

Use 4-conductor VCTF cable for communications when Water-resistant Terminals are used.

Wire the cables as shown below regardless of whether the system has a main line distinguished from the branch lines or not.

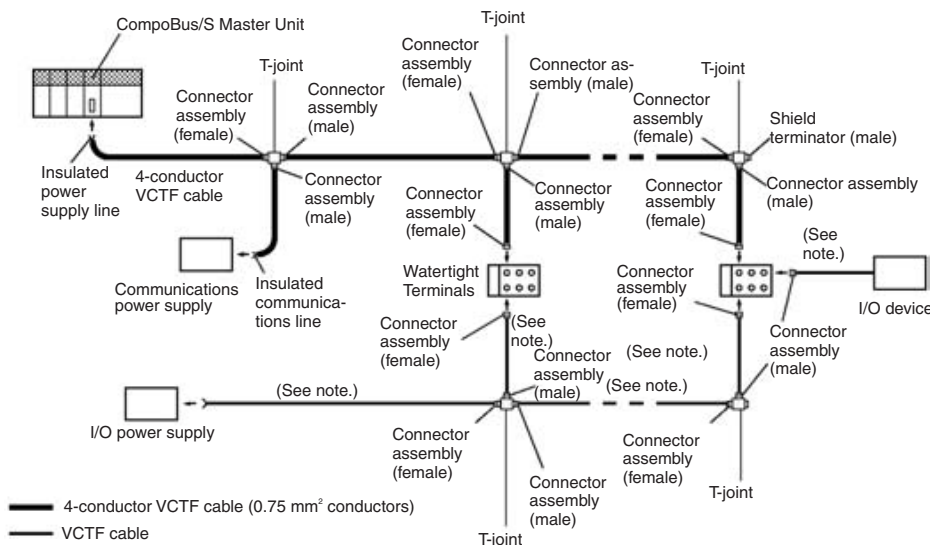

Note Use VCTF cable for the external power supply. OMRON's Connectors with Cables can be used as well.

To connect Slaves other than the Water-resistant Terminals, use communications cable with no connectors and wire the cable with crimp terminals. If the cable requires water resistance, use a commercially available terminal block instead of T-joints.

Note When using 4-conductor VCTF Connector with Cable Assemblies, use one of the following combinations of cable conductor colors and signals for stable communications.

Conductor color	Signal			
	Pattern 1	Pattern 2	Pattern 3	Pattern 4
White	BD H	BS +	BS -	BD L
Red	BS +	BS -	BD L	BD H
Green	BS -	BD L	BD H	BS +
Black	BD L	BD H	BS +	BS -

2-5 I/O Response Time Characteristics

This section explains the minimum and maximum I/O response times of the CompoBus/S System. Use this section for reference when planning operations that require precise I/O timing.

The I/O response time is the time it takes from the reception of an input signal at a CompoBus/S Input Slave to the output of the corresponding output signal at a CompoBus/S Output Slave.

The information provided here, however, is only for when a Communications Unit is used as the Master Unit. For details on using the SRM1 Master Control Unit and CPM2C-S Series, refer to the *CompoBus/S SRM1 Master Control Units Operation Manual (W318)* or *CPM2C-S PLC Operation Manual (W377)*.

2-5-1 Slaves Other Than Analog Terminals

Minimum I/O Response Time

The following timing chart shows the minimum I/O response time.

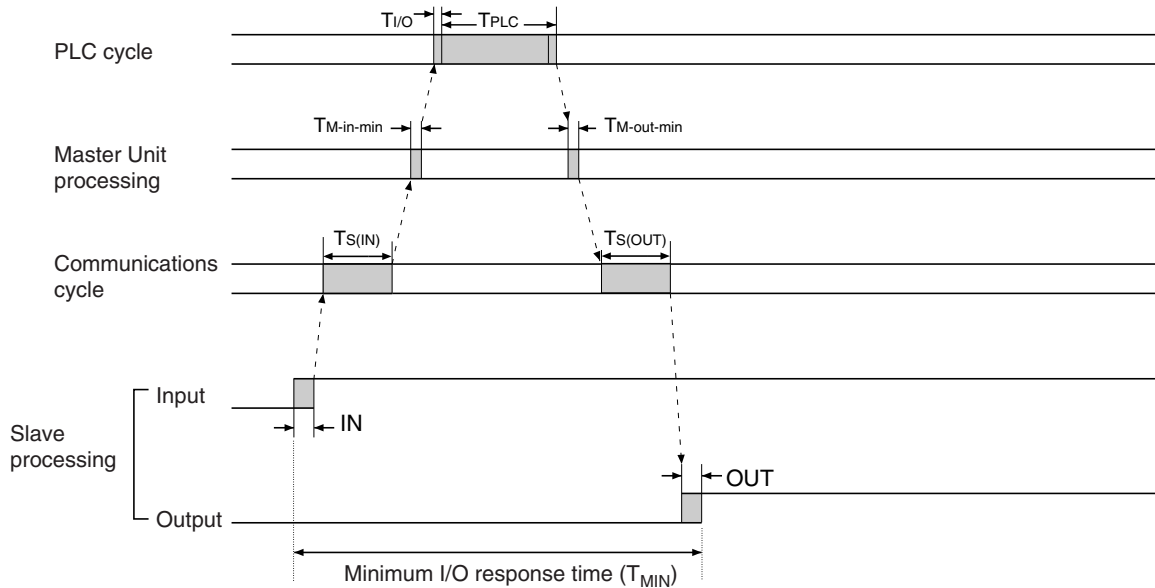

The minimum I/O response time is the total of the following terms:

$$T_{MIN} = IN + T_{S(IN)} + T_{M-in-min} + T_{I/O} + T_{PLC} + T_{M-out-min} + T_{S(OUT)} + OUT$$

T_{MIN} : Minimum I/O response time

T_{PLC} : PLC's cycle time

IN: Input delay in the Slave (Refer to 2-5-3 Slave I/O Delay Times on page 51.)

OUT: Output delay in the Slave (Refer to 2-5-3 Slave I/O Delay Times on page 51.)

$T_{S(IN)}$: Input data transmission time for one node.
High-speed Communications Mode: 20 μ s

Long-distance Communications Mode: 160 μ s

$T_{M-in-min}$: Minimum input processing time in the Master
CS-series, C200HX/HG/HE-(Z)E, C200HS, or CQM1 Master Unit:

$T_{M-in-min} = 0 \mu$ s

CS-series Master Units:

$T_{M-in-min} = 20 \mu$ s (allocated words for 1 unit number),
25 μ s (allocated words for 2 unit numbers)

CJ-series Master Units:

$T_{M-in-min} = 25 \mu$ s

$T_{M-out-min}$: Minimum output processing time in the Master

CS-series, C200HX/HG/HE-(Z)E, C200HS, or CQM1 Master Unit:
 $T_{M-out-min} = 0 \mu$ s

CS-series Master Units:

$T_{M-out-min} = 33 \mu$ s (allocated words for 1 unit number),
43.5 μ s (allocated words for 2 unit numbers)

CJ-series Master Unit:

$T_{M-out-min} = 45 \mu$ s

$T_{S(OUT)}$: Output data transmission time for one node.

High-speed Communications Mode: 15 μ s

$T_{I/O}$: Long-distance Communications Mode: 110 μ s
 I/O refreshing time

CS-series, C200HX/C200HG/C200HE-(Z)E, and C200HS Master Units

PLC	Usable node number setting	
	IN0 to IN7 and OUT0 to OUT7	IN0 to IN15 and OUT0 to OUT15
CS Series, and C200HX/C200HG/ C200HE-(Z)E	$T_{I/O} = 440 \mu$ s	$T_{I/O} = 880 \mu$ s
C200HS	$T_{I/O} = 1,000 \mu$ s	$T_{I/O} = 2,000 \mu$ s

CS-series Master Units

PLC	Usable node number setting	
	IN0 to IN7 and OUT0 to OUT7	IN0 to IN15 and OUT0 to OUT15
CS1 (without -H suffix)	$T_{I/O} = 160 \mu$ s	$T_{I/O} = 180 \mu$ s
CS1-H	$T_{I/O} = 120 \mu$ s	$T_{I/O} = 130 \mu$ s

- Note**
1. The values in the above table are applicable when connected to the CPU Rack. Add another 20 μ s to the values shown in the table when connecting to an Expansion Rack.
 2. Add another 20 μ s to the values shown in the table when using the Slave registration function or communications stop mode.

CJ-series Master Units

PLC	Usable node number setting	
	IN0 to IN7 and OUT0 to OUT7	IN0 to IN15 and OUT0 to OUT15
CJ1 (without -H suffix)	$T_{I/O} = 160 \mu$ s	$T_{I/O} = 180 \mu$ s
CJ1-H	$T_{I/O} = 120 \mu$ s	$T_{I/O} = 130 \mu$ s

- Note**
1. The values in the above table are applicable when connected to the CPU Rack. Add another 20 μ s to the values shown in the table when connecting to an Expansion Rack.
 2. Add another 20 μ s to the values shown in the table when using the Slave registration function or communications stop mode.

CQM1 Master Units

PLC	PLC word allocation setting		
	2 words	4 words	8 words
CQM1	$T_{I/O} = 15 \mu$ s	$T_{I/O} = 30 \mu$ s	$T_{I/O} = 60 \mu$ s

Maximum I/O Response Time

The following timing chart shows the maximum I/O response time.

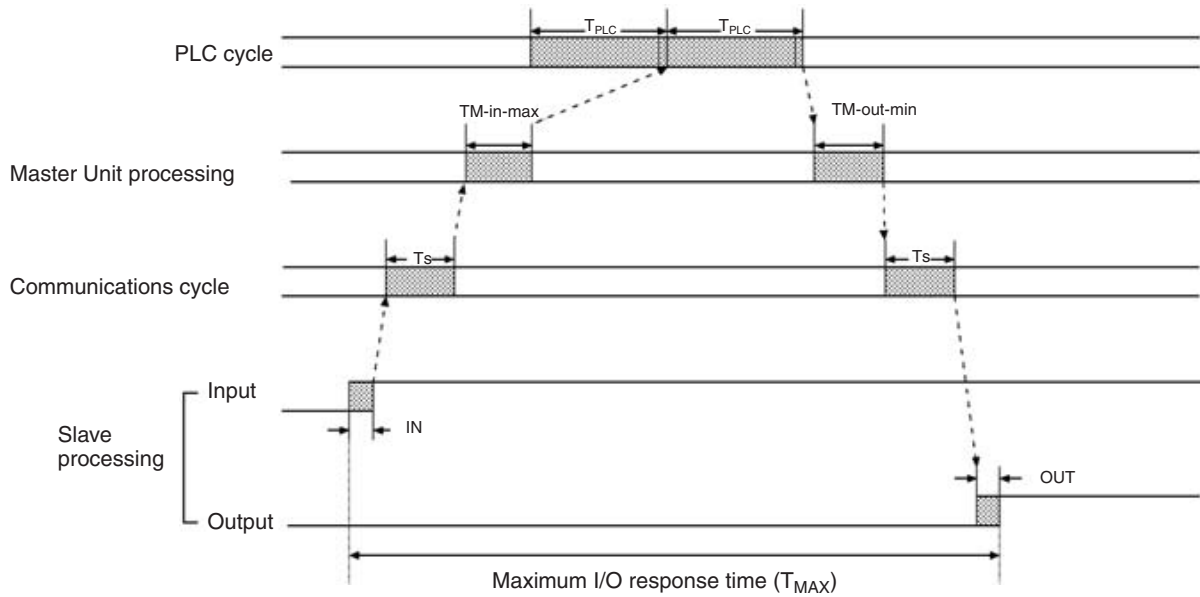

The maximum I/O response time is the total of the following terms:

$$T_{MAX} = IN + T_S + T_{M-in-max} + T_{PLC} \times 2 + T_{M-out-max} + T_S + OUT$$

T_{MAX} : Maximum I/O response time

T_{PLC} : PLC's cycle time

IN : Input delay in the Slave (Refer to 2-5-3 Slave I/O Delay Times on page 51.)

OUT : Output delay in the Slave (Refer to 2-5-3 Slave I/O Delay Times on page 51.)

T_S : Communications cycle time

Master	Usable node number setting	Communications cycle time	
		High-speed Communications Mode	Long-distance Communications Mode
CS-series, C200HX/C200HG/C200HE-(Z)E, and C200HS Master Unit, CS-series Master Unit, or CJ-series Master Unit	IN0 to IN7 and OUT0 to OUT7	500 μ s	4,000 μ s
	IN0 to IN15 and OUT0 to OUT15	800 μ s	6,000 μ s
CQM1	IN0 to IN1 and OUT0 to OUT1	500 μ s	4,000 μ s
	IN0 to IN3 and OUT0 to OUT3		
	IN0 to IN7 and OUT0 to OUT7		
	IN0 to IN15 and OUT0 to OUT15	800 μ s	6,000 μ s

$T_{M-in-max}$: Maximum input processing time in the Master

CS-series, C200HX/C200HG/C200HE-(Z)E, and C200HS Master Units

Master	Number of points/ node number	Max. input processing time
CS Series, C200HX/ C200HG/ C200HE-(Z)E, and C200HS	---	470 μ s

CS-series Master Units

Master	Usable node number setting	
	IN0 to IN7 and OUT0 to OUT7	IN0 to IN15 and OUT0 to OUT15
CS1 (without -H suffix)	$T_{M-in-max} = 270 \mu$ s	$T_{M-in-max} = 320 \mu$ s
CS1-H	$T_{M-in-max} = 220 \mu$ s	$T_{M-in-max} = 270 \mu$ s

Note Add another 15 μ s to the values in the table when using the Slave registration function or communications stop mode.

CJ-series Master Units

Master	Usable node number setting	
	IN0 to IN7 and OUT0 to OUT7	IN0 to IN15 and OUT0 to OUT15
CJ1 (without -H suffix)	$T_{M-in-max} = 270 \mu$ s	$T_{M-in-max} = 320 \mu$ s
CJ1-H	$T_{M-in-max} = 220 \mu$ s	$T_{M-in-max} = 270 \mu$ s

Note Add another 15 μ s to the values in the table when using the Slave registration function or communications stop mode.

CQM1 Master Units

Master	Number of points/ node number	Max. input processing time
CQM1	8-point mode	300 μ s
	4-point mode	860 μ s

$T_{M-out-max}$: Maximum output processing time in the Master

CS-series, C200HX/C200HG/C200HE-(Z)E, and C200HS Master Units

Master	Number of points/ node number	Max. output processing time
CS-series, C200HX/ C200HG/ C200HE-(Z)E, and C200HS Masters	---	650 μ s

CS-series Master Units

Master	Usable node number setting	
	IN0 to IN7 and OUT0 to OUT7	IN0 to IN15 and OUT0 to OUT15
CS1	$T_{M-out-max} = 100 \mu$ s	$T_{M-out-max} = 130 \mu$ s

Note Add another 15 μ s to the values in the table when using the Slave registration function or communications stop mode.

CJ-series Master Units

Master	Usable node number setting	
	IN0 to IN7 and OUT0 to OUT7	IN0 to IN15 and OUT0 to OUT15
CJ1	$T_{M-out-max} = 100 \mu s$	$T_{M-out-max} = 130 \mu s$

Note Add another 15 μs to the values in the table when using the Slave registration function or communications stop mode.

CQM1 Master Units

Master	Number of points/ node number	Max. output pro- cessing time
CQM1	8-point mode	480 μs
	4-point mode	1,040 μs

Recognition of Slave I/O Status at Startup

When the CompoBus/S System is turned ON, the I/O of Slaves connected to CQM1 Masters may not become effective at the same time as the I/O of Slaves connected to CS-series, CJ-series, C200HX/C200HG/C200HE-(Z)E, and C200HS Masters.

CS-series, CJ-series, C200HX/C200HG/C200HE-(Z)E, and C200HS Masters

The I/O of a Slave connected to a CS-series, C200HX/C200HG/C200HE-(Z)E, C200HS, or CJ-series Master becomes effective when the Active Node Flag for the Slave goes ON.

CQM1 Masters

The I/O of a Slave connected to a CQM1 Master becomes effective some time after the Master's PLC is turned ON.

In High-speed Communications Mode: (PLC cycle time) + 118 ms

In Long-distance Communications Mode: (PLC cycle time) + 720 ms.

2-5-2 Slave Analog Terminals

Minimum I/O Response Time

The following timing chart shows the minimum I/O response time.

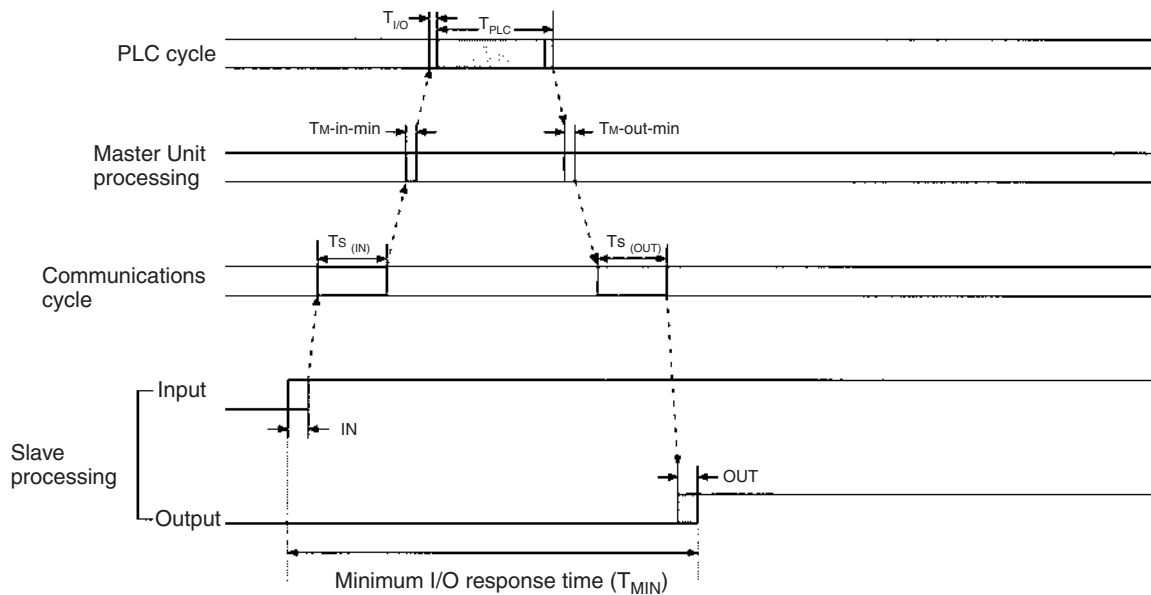

The minimum I/O response time is the total of the following terms:

$$T_{MIN} = IN + T_{S(IN)} + T_{M-in-min} + T_{I/O} + T_{PLC} + T_{M-out-min} + T_{S(OUT)} + OUT$$

T_{MIN} : Minimum I/O response time

T_{PLC} : PLC's cycle time

T_s (IN): Input data transmission time for one node

High-speed Communications Mode: 20 μ s

Long-distance Communications Mode: 160 μ s

$T_{M-in-min}$: Input processing time in the Master

Master	Input processing time
CS Series, C200HX/C200HG/ C200HE-(Z)E, and C200HS	160 μ s
CS Series	20 μ s (allocated words for 1 unit number), 25 μ s (allocated words for 2 unit numbers)
CJ Series	25 μ s
CQM1	120 μ s

$T_{M-out-min}$: Minimum output processing time in the Master

Master	Min. input processing time
CS Series, C200HX/C200HG/ C200HE-(Z)E, and C200HS	35 μ s
CS Series	35 μ s (allocated words for 1 unit number), 45 μ s (allocated words for 2 unit numbers)
CJ Series	45 μ s
CQM1	40 μ s

T_s (OUT): Output data transmission time for one node

High-speed Communications Mode: 15 μ s

Long-distance Communications Mode: 110 μ s

IN: Input delay in the Slave (Minimum value is 0.)

OUT: Output delay in the Slave (Minimum value is 0.)

$T_{I/O}$: I/O refreshing time

CS-series, C200HX/C200HG/C200HE-(Z)E, and C200HS Master Units

Master	Usable node number setting	
	IN0 to IN7 and OUT0 to OUT7	IN0 to IN15 and OUT0 to OUT15
CS Series, C200HX/ C200HG/ C200HE-(Z)E	$T_{I/O} = 440 \mu$ s	$T_{I/O} = 880 \mu$ s
C200HS	$T_{I/O} = 1,000 \mu$ s	$T_{I/O} = 2,000 \mu$ s

CS-series Master Units

Master	Usable node number setting	
	IN0 to IN7 and OUT0 to OUT7	IN0 to IN15 and OUT0 to OUT15
CS1 (without -H suffix)	$T_{I/O} = 160 \mu$ s	$T_{I/O} = 180 \mu$ s
CS1-H	$T_{I/O} = 120 \mu$ s	$T_{I/O} = 130 \mu$ s

Note 1. The values in the above table are applicable when connected to the CPU Rack. Add another 20 μ s to the values shown in the table when connected to an Expansion Rack.

2. Add another 20 μs to the values shown in the table when using the Slave registration function or communications stop mode.

CJ-series Master Units

Master	Usable node number setting	
	IN0 to IN7 and OUT0 to OUT7	IN0 to IN15 and OUT0 to OUT15
CJ1 (without -H suffix)	T _{I/O} = 160 μs	T _{I/O} = 180 μs
CJ1-H	T _{I/O} = 120 μs	T _{I/O} = 130 μs

- Note**
1. The values in the above table are applicable when connected to the CPU Rack. Add another 20 μs to the values shown in the table when connected to an Expansion Rack.
 2. Add another 20 μs to the values shown in the table when using the Slave registration function or communications stop mode.

CQM1 Master Units

Master	PLC word allocation setting		
	2 words	4 words	8 words
CQM1	T _{I/O} = 15 μs	T _{I/O} = 30 μs	T _{I/O} = 60 μs

Maximum I/O Response Time

The following timing chart shows the maximum I/O response time.

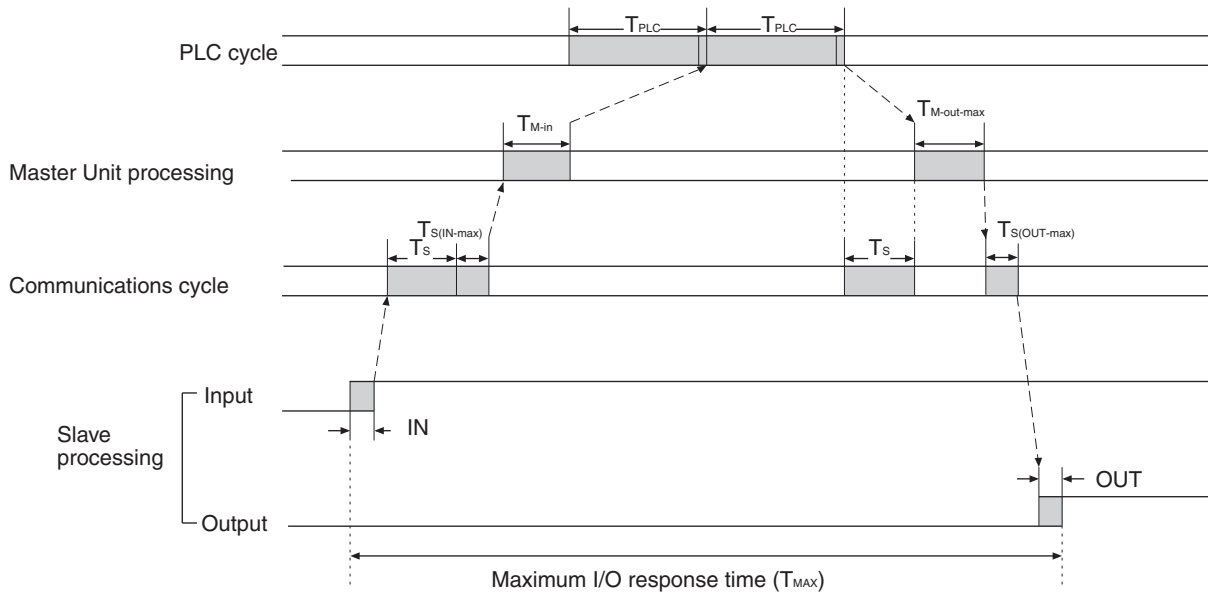

The maximum I/O response time is the total of the following terms:

$$T_{MAX} = IN + T_S \times 3 + T_{M-in} + T_{PLC} \times 2 + T_{M-out-max} + OUT$$

$$(T_S = T_{S(IN-max)} + T_{S(OUT-max)})$$

- T_{MAX}: Maximum I/O response time
- T_{PLC}: PLC's cycle time
- IN: Input delay in the Slave (Refer to 2-5-3 Slave I/O Delay Times.)
- OUT: Output delay in the Slave (Refer to 2-5-3 Slave I/O Delay Times.)
- T_S: Communications cycle time = T_{S(IN-max)} + T_{S(OUT-max)}

$T_{S (IN-max)}$: Communications cycle input time

$T_{S (OUT-max)}$: Communications cycle output time

Master	Usable node number setting	Communications cycle time	
		High-speed Communications Mode	Long-distance Communications Mode
CS-series, C200HX/C200HG/C200HE-(Z)E, and C200HS Master Unit, CS-series Master Unit, or CJ-series Master Unit	IN0 to IN7 and OUT0 to OUT7	500 μ s	4,000 μ s
	IN0 to IN15 and OUT0 to OUT15	800 μ s	6,000 μ s
CQM1	IN0 to IN1 and OUT0 to OUT1	500 μ s	4,000 μ s
	IN0 to IN3 and OUT0 to OUT3		
	IN0 to IN7 and OUT0 to OUT7		

T_{M-IN} : Input processing time in the Master

Master	Input processing time
CS Series, C200HX/C200HG/C200HE-(Z)E, and C200HS	160 μ s
CQM1	120 μ s

CS-series Master Units

Usable node number setting	
IN0 to IN7 and OUT0 to OUT7	IN0 to IN15 and OUT0 to OUT15
$T_{M-IN} = 100 \mu$ s	$T_{M-IN} = 130 \mu$ s

Note Add another 15 μ s to the values shown in the table when using the Slave registration function or communications stop mode.

CJ-series Master Units

Usable node number setting	
IN0 to IN7 and OUT0 to OUT7	IN0 to IN15 and OUT0 to OUT15
$T_{M-IN} = 100 \mu$ s	$T_{M-IN} = 130 \mu$ s

Note Add another 15 μ s to the values shown in the table when using the Slave registration function or communications stop mode.

$T_{M-out-max}$: Maximum output processing time in the Master

Master	Max. input processing time
CS Series, C200HX/C200HG/C200HE-(Z)E, and C200HS	200 μ s
CQM1	230 μ s

CS-series Master Units

Usable node number setting	
IN0 to IN7 and OUT0 to OUT7	IN0 to IN15 and OUT0 to OUT15
$T_{M-out-max} = 130 \mu$ s	$T_{M-out-max} = 140 \mu$ s

Note Add another 15 μs to the values shown in the table when using the Slave registration function or communications stop mode.

CJ-series Master Units

Usable node number setting	
IN0 to IN7 and OUT0 to OUT7	IN0 to IN15 and OUT0 to OUT15
$T_{M\text{-out-max}} = 130 \mu\text{s}$	$T_{M\text{-out-max}} = 140 \mu\text{s}$

Note Add another 15 μs to the values shown in the table when using the Slave registration function or communications stop mode.

Recognition of Slave I/O Status at Startup

When the CompoBus/S System is turned ON, the I/O of Slaves connected to CQM1 Masters may not become effective at the same time as the I/O of Slaves connected to CS-series, CJ-series, C200HX/C200HG/C200HE-(Z)E, and C200HS Masters.

CS-series, CJ-series, C200HX/C200HG/C200HE-(Z)E, and C200HS Masters

The I/O of a Slave connected to a CS-series, CJ-series, C200HX/C200HG/C200HE-(Z)E, and C200HS Master becomes effective when the Active Node Flag for the Slave goes ON.

CQM1 Masters

The I/O of a Slave connected to a CQM1 Master becomes effective some time after the Master's PLC is turned ON.

In High-speed Communications Mode: (PLC cycle time) +118 ms

In Long-distance Communications Mode: (PLC cycle time) +720 ms.

2-5-3 Slave I/O Delay Times

Model	Specifications	Input specifications		Output specifications	
		ON delay time	OFF delay time	ON delay time (See note 1.)	OFF delay time (See note 2.)
SRT1-ID04(-1)	4-point input terminal block	1.5 ms max.	1.5 ms max.	---	---
SRT1-ID08(-1)	8-point input terminal block	1.5 ms max.	1.5 ms max.	---	---
SRT1-ID16(-1)	16-point input terminal block	1.5 ms max.	1.5 ms max.	---	---
SRT1-ID16T(-1)	16-point input 3-tier terminal block	1.5 ms max.	1.5 ms max.	---	---
SRT1-OD04(-1)	4-point output terminal block	---	---	0.5 ms max.	1.5 ms max.
SRT1-OD08(-1)	8-point output terminal block	---	---	0.5 ms max.	1.5 ms max.
SRT1-OD16(-1)	16-point output terminal block	---	---	0.5 ms max.	1.5 ms max.
SRT1-OD16T(-1)	16-point output 3-tier terminal block	---	---	0.5 ms max.	1.5 ms max.
SRT1-MD16T(-1)	8-point output, 8-point input 3-tier terminal block	1.5 ms max.	1.5 ms max.	0.5 ms max.	1.5 ms max.
SRT1-ROC08	8-point relay output	---	---	10 ms max.	10 ms max.
SRT1-ROC16	16-point relay output	---	---	10 ms max.	10 ms max.
SRT1-ROF08	8-point power MOSFET output	---	---	6 ms max.	10 ms max.
SRT1-ROF16	16-point power MOSFET output	---	---	6 ms max.	10 ms max.
SRT2-ID04(-1)	4-point input terminal block	1.5 ms max.	1.5 ms max.	---	---
SRT2-ID08(-1)	8-point input terminal block	1.5 ms max.	1.5 ms max.	---	---
SRT2-ID16(-1)	16-point input terminal block	1.5 ms max.	1.5 ms max.	---	---
SRT2-ID16T(-1)	16-point input 3-tier terminal block	1.5 ms max.	1.5 ms max.	---	---
SRT2-OD04(-1)	4-point output terminal block	---	---	0.5 ms max.	1.5 ms max.
SRT2-OD08(-1)	8-point output terminal block	---	---	0.5 ms max.	1.5 ms max.
SRT2-OD16(-1)	16-point output terminal block	---	---	0.5 ms max.	1.5 ms max.
SRT2-OD16T(-1)	16-point output 3-tier terminal block	---	---	0.5 ms max.	1.5 ms max.
SRT2-MD16T(-1)	8-point output, 8-point input 3-tier terminal block	1.5 ms max.	1.5 ms max.	0.5 ms max.	1.5 ms max.
SRT2-ROC08	8-point relay output	---	---	10 ms max.	10 ms max.
SRT2-ROC16	16-point relay output	---	---	10 ms max.	10 ms max.
SRT2-ROF08	8-point power MOSFET output	---	---	6 ms max.	10 ms max.
SRT2-ROF16	16-point power MOSFET output	---	---	6 ms max.	10 ms max.
SRT2-VID08S(-1)	8-point input sensor connector	1.5 ms max.	1.5 ms max.	---	---
SRT2-VID16ML(-1)	16-point input MIL connector	1.5 ms max.	1.5 ms max.	---	---
SRT2-ID32ML(-1)	32-point input MIL connector	1.5 ms max.	1.5 ms max.	---	---
SRT2-MD32ML(-1)	16-point input, 16-point output MIL connector	1.5 ms max.	1.5 ms max.	0.5 ms max.	1.5 ms max.
SRT2-VOD08S(-1)	8-point output sensor connector	---	---	0.5 ms max.	1.5 ms max.
SRT2-VOD16ML(-1)	16-point output MIL connector	---	---	0.5 ms max.	1.5 ms max.
SRT2-OD32ML(-1)	32-point output MIL connector	---	---	0.5 ms max.	1.5 ms max.
SRT1-ID16P	16-point input, PCB attachment	1.5 ms max.	1.5 ms max.	---	---
SRT1-OD16P	16-point output, PCB attachment	---	---	0.5 ms max.	1.5 ms max.
SRT2-ID16P	16-point input, PCB attachment	1.5 ms max.	1.5 ms max.	---	---
SRT2-OD16P	16-point output, PCB attachment	---	---	0.5 ms max.	1.5 ms max.
SRT2-AD04	Analog 4-point input	AD conversion time: 4 ms max.		---	---
SRT2-DA02	Analog 2-point output	DA conversion time: 2 ms max.		---	---
SRT1-ID08S	8-point input sensor terminal	1 ms max.	1.5 ms max.	---	---
SRT2-ID08S	8-point input sensor terminal	1 ms max.	1.5 ms max.	---	---
SRT1-ND08S	4-point input, 4-point output sensor terminal	1 ms max.	1.5 ms max.	1.0 ms max.	1.5 ms max.

Model	Specifications	Input specifications		Output specifications	
		ON delay time	OFF delay time	ON delay time (See note 1.)	OFF delay time (See note 2.)
SRT2-ND08S	4-point input, 4-point output sensor terminal	1 ms max.	1.5 ms max.	1.0 ms max.	1.5 ms max.
SRT1-OD08S	8-point output sensor terminal	---	---	0.5 ms max.	1.5 ms max.
SRT2-OD08S	8-point output sensor terminal	---	---	0.5 ms max.	1.5 ms max.
SRT2-ID04CL(-1)	4-point input water-resistant terminal	1.5 ms max.	1.5 ms max.	---	---
SRT2-ID08CL(-1)	8-point input water-resistant terminal	1.5 ms max.	1.5 ms max.	---	---
SRT2-OD04CL(-1)	4-point output water-resistant terminal	---	---	0.5 ms max.	1.5 ms max.
SRT2-OD08CL(-1)	8-point output water-resistant terminal	---	---	0.5 ms max.	1.5 ms max.
E3X-SRT21	8-point/16-point input Fiber Amplifier Communications Unit	See below.		---	---

- Note**
1. This is the ON response time for the SRT□-ROC□□
 2. This is the OFF response time for the SRT□-ROF□□

Maximum Input Delay Time for Fiber Amplifier Communications Unit

- For up to 8 sensors connected:
Maximum ON/OFF data input delay time for unit $n = 0.1 \times n + 1.5$ (ms)
- For 9 sensors or more connected:
Maximum ON/OFF data input delay time for unit $n = 0.2 \times n + 1.5$ (ms)

SECTION 3

CompoBus/S System Wiring

This section explains how to install Units in control panels, wire the signal and power lines, and make other connections needed to assemble a CompoBus/S System.

3-1	Mounting	54
3-1-1	Master Unit Mounting	54
3-1-2	Slave Unit Mounting	54
3-2	Connector Installation (Special Flat Cable Only)	55
3-2-1	Branch Connector	56
3-2-2	Extension Connector	59
3-2-3	Connector Terminator	62
3-3	VCTF Cable Assembly	64
3-3-1	Branching and Extending VCTF Cable	64
3-3-2	Installing Terminators	65
3-4	Master/Slave Connecting Cables	66
3-4-1	Crimp Terminal Installation	66
3-4-2	Master and Slave Terminal Connections	67
3-4-3	Cable Connector Wiring and Assembly	67
3-5	Operations Checklist	70

3-1 Mounting

⚠ Caution A label is stuck to some Masters and Slaves to prevent pieces of wire from entering the Units. Install and wire the Units with the labels in place. Stray strands of wire could cause malfunctions. Always remove the label after installation and wiring to facilitate cooling. The Units could overheat and malfunction if the labels are not removed.

3-1-1 Master Unit Mounting

The Master Unit mounts to the PLC itself, just like other Units. This section explains only the precautions that should be taken during Master Unit installation. Refer to the PLC's Installation Guide for details on mounting Units to the PLC or installing the PLC in a control panel.

This section provides information on Communications Master Units. For the SRM1 Master Control Unit and CPM2C-S Series, refer to the *SRM1 Operation Manual* and *CPM2C-S Operation Manual*.

3-1-2 Slave Unit Mounting

This section explains how to mount a Slave in a control panel.

Basically, there are two methods that can be used to mounted a Slave: Screws or DIN Track. Some Slaves allow only one of these methods, while other Slaves, such as the Remote I/O Modules, mounted directly to a board. Others are mounted with special mounting brackets.

Required Parts

The following parts are required to attach a Slave to a DIN track. These parts are not required when attaching a Slave to a control panel with screws.

Part	Model number	Comments
35-mm DIN track	PFP-50N	50 cm long
	PFP-100N	100 cm long
	PFP-100N2	100 cm long
End Plate	PFP-M	Two are required for each Slave.

Direct Mounting with Screws

Refer to the Slave's dimension diagram in *SECTION 5 Slave Specifications and Operations* for a template showing the mounting hole placement. Drill the specified holes in the control panel and install the Slave with the right screws to the specified tightening torque as given below.

M4 screw: 0.6 to 0.98 N·m

M5 screw (Front mounting): 0.6 to 1.18 N·m

M5 screw (Rear mounting): 1.47 to 1.96 N·m

DIN Track Mounting

Clip the back of the Slave on to the DIN track by holding down the mounting pins on the back of the Slave with a screwdriver, pushing the bottom of the Slave onto the DIN track, and then rotating the Slave up and over the top of

the track. Attach End Plates at the sides of the Slave to prevent it from sliding on the track.

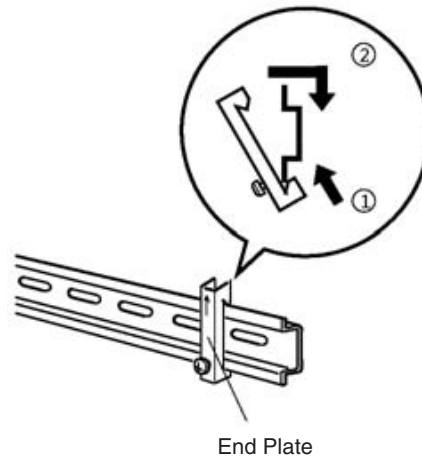

Caution Always secure the Slave on the DIN track by installing End Plates on each side.

Mounting Direction

Any of the following six mounting directions can be used, unless specified in the Slave’s operation manual.

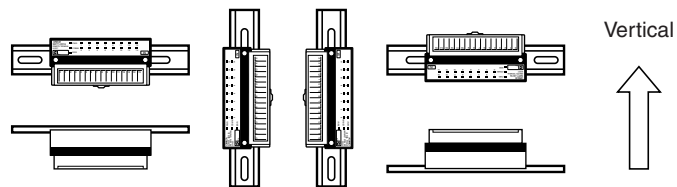

3-2 Connector Installation (Special Flat Cable Only)

The cable connections can be made with simple connectors if Special Flat Cable is used for the communications cable. There are three types of connectors: the Branch Connector (refer to 3-2-1 Branch Connector), Extension Connector (refer to 3-2-2 Extension Connector), and Connector Terminator (refer to 3-2-3 Connector Terminator).

Caution Connectors cannot be reused once they have been attached to a cable. Be sure that the connectors are positioned correctly before attaching them.

Caution Wire the communications cable separately from power lines and high-voltage lines to prevent any noise.

Caution If Special Flat Cables are used for multiple CompoBus/S Systems, install the cables at least 5 mm apart from other Special Flat Cables to prevent unstable operation due to mutual interference in the CompoBus/S Systems.

When Special Flat Cable cable is used, determine which wires are to be used, as shown in the following diagram.



3-2-1 Branch Connector

Branch Connectors are used to make branches from the main line. A commercially available terminal block can also be used to make branches.

Connector Components

The Branch Connector has three components: Cover 1, Cover 2, and the contact block. The following diagram shows Cover 1.

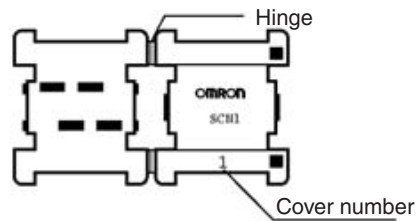

The following diagram shows Cover 2.

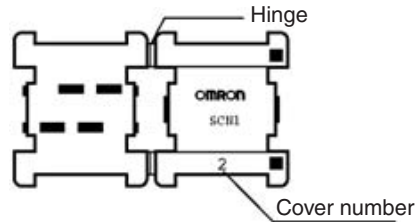

The following diagram shows the contact block.

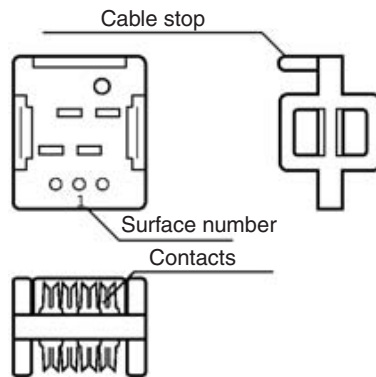

Note Cover 1 and Cover 2 can be distinguished by the cover number.

Installation Procedure

Use the following procedure to attach a Branch Connector to the communications cable.

The following procedure is an example to branch the main cable. The same procedure will apply even if the main line does not need to be distinguished from the branch lines.

- 1,2,3...** 1. Make a perpendicular cut in the cable that will be used as the branch line (the branch cable). The cable will not fit in the connector properly if the cut is not straight and perpendicular.

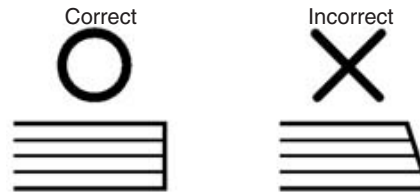

2. Snap Cover 1 onto the branch cable. Make sure that the hook locks into place.

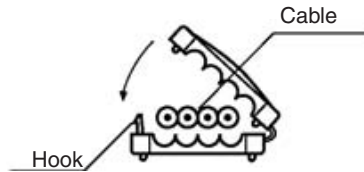

3. Line up the end of Cover 1 with the end of the branch cable.

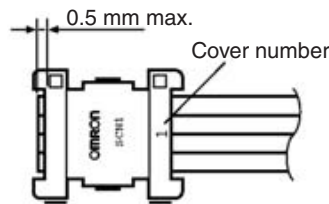

4. Position Cover 1 onto Surface 1 of the contact block (the side with the cable stop). The pattern of the contact block is different on Surface 2, so Cover 1 cannot be fitted on Surface 2.

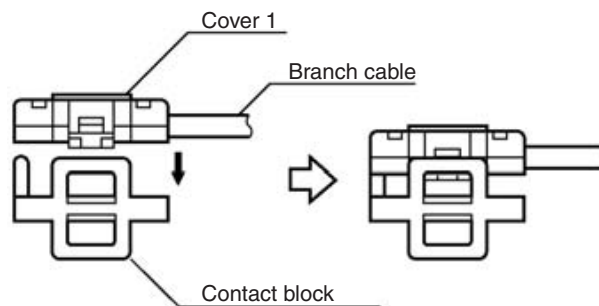

5. Snap Cover 2 onto the cable being used as the main line (the main cable). Make sure that the hook locks into place. Cover 2 can still slide along the cable when locked.

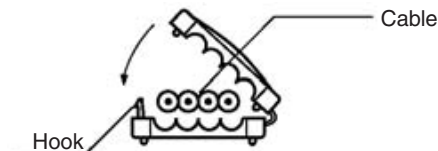

6. Slide Cover 2 to the point on the main cable where you want the branch line.

7. Position Cover 2 onto Surface 2 of the contact block (the side without the cable stop). Always align the cables so that the main cable's colors match the branch cable's colors.

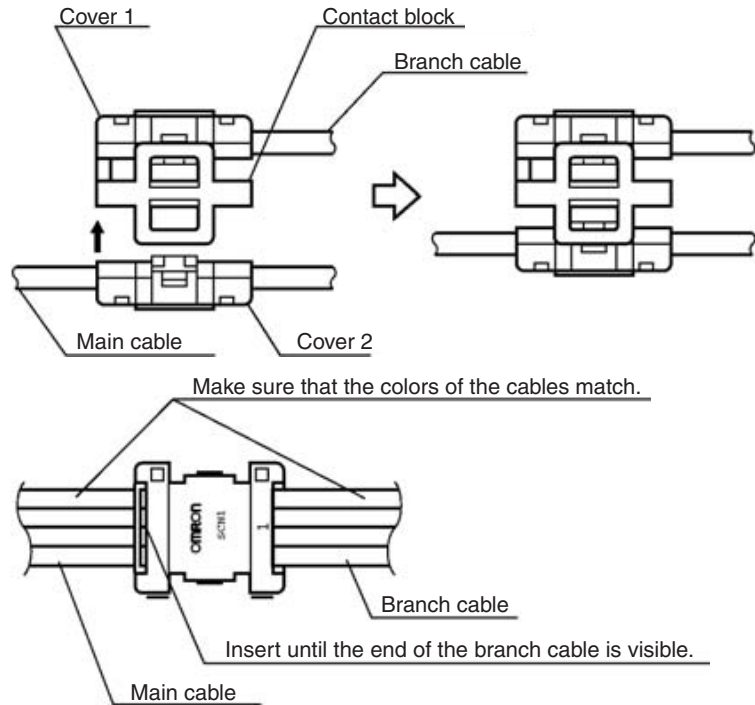

⚠ Caution The Units could be damaged if the branch cable's colors do not match the main cable's colors.

8. The branch cable must be inserted all the way to the contact block's cable stop.
9. Use a tool such as pliers to compress Cover 1 and Cover 2 together.

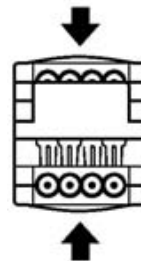

⚠ Caution Always align the tool with the centers of the Covers to prevent any bending or distortion when the connector is compressed. Uneven compression can prevent proper communications.

- 10. Check the assembled connector from the side and make sure that the locks are completely engaged, as shown in the following diagram.

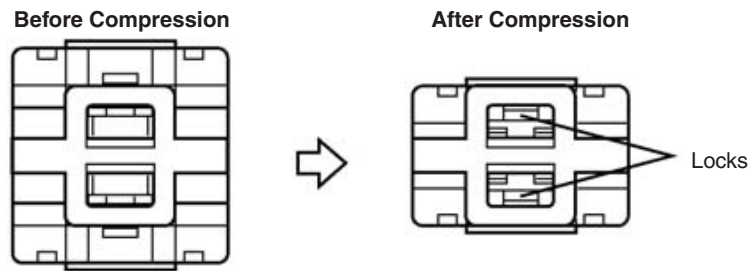

3-2-2 Extension Connector

Extension Connectors can be connected to any point of the communications cable regardless of whether it is a main or branch line or whether the main line needs to be distinguished from the branch lines.

Connector Components

The Extension Connector has three components: Cover 1, Cover 2, and the contact block. The following diagram shows Cover 1.

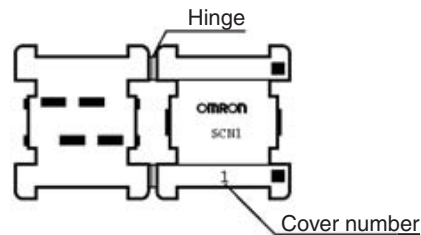

The following diagram shows Cover 2.

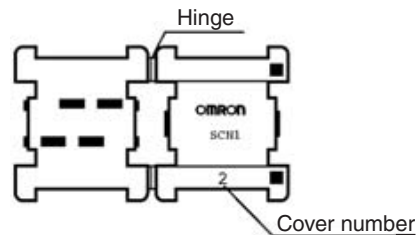

The following diagram shows the contact block.

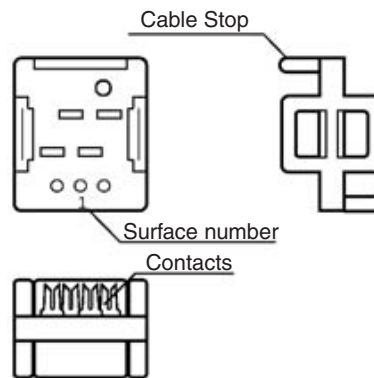

Note Cover 1 and Cover 2 can be distinguished by the cover number.

Installation Procedure

Use the following procedure to attach a Extension Connector to the communications cable.

1,2,3...

1. Make perpendicular cuts in the cables being connected. The cables will not fit in the connector properly if the cuts are not straight and perpendicular.

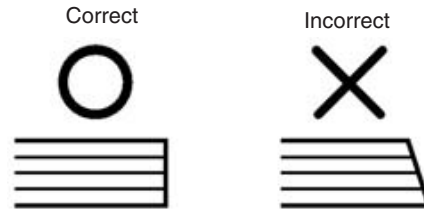

2. Snap Cover 1 onto one of the cables. Make sure that the hook locks into place.

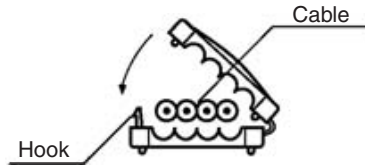

3. Line up the end of Cover 1 with the end of the cable.

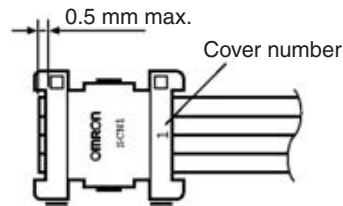

4. Position Cover 1 onto Surface 1 of the contact block.

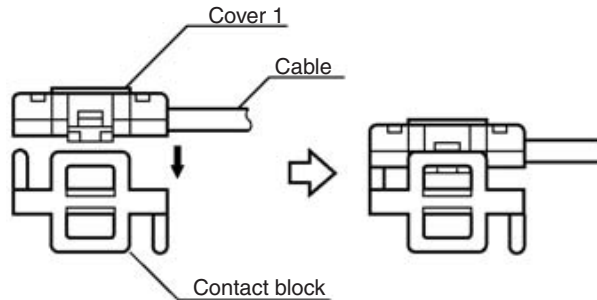

Note The patterns of the contact blocks are different, so Cover 1 cannot be fitted on Surface 2.

5. Snap Cover 2 onto the other cable. Make sure that the hook locks into place.

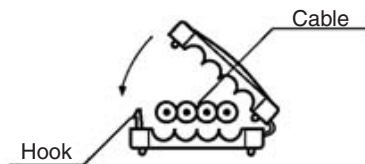

- 6. Line up the end of Cover 2 with the end of the cable.

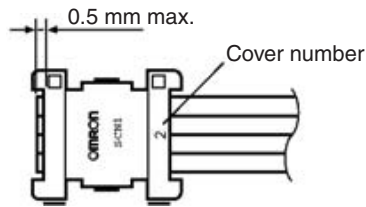

- 7. Position Cover 2 onto Surface 2 of the contact block. Always align the cables so that their colors match.

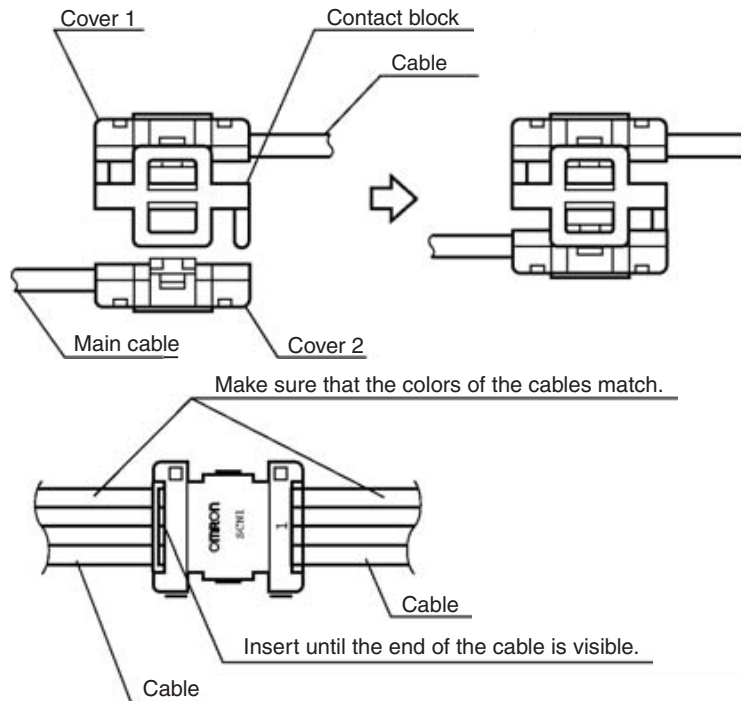

Caution The Units could be damaged if the cables' colors do not match.

- 8. Make sure that each cable has been inserted all the way to the contact block's cable stop.
- 9. Use a tool such as pliers to compress Cover 1 and Cover 2 together.

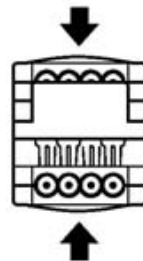

Caution Always align the tool with the centers of the Covers to prevent any bending or distortion when the connector is compressed. Uneven compression can prevent proper communications.

- 10. Check the assembled connector from the side and make sure that the locks are completely engaged, as shown in the following diagram.

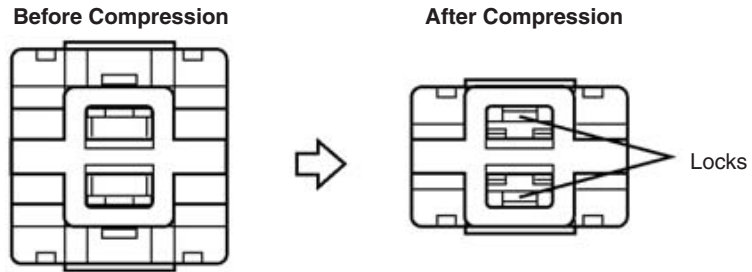

3-2-3 Connector Terminator

When the system has a main line that needs to be distinguished from the branch lines, a Connector Terminator is connected at the end of main line opposite the Master. If the main line does not need to be distinguished from the branch lines, a Connector Terminator is connected the end of the communications cable farthest from the Master.

Connector Components

The Connector Terminator has two components: Cover 1 and the contact block. The following diagram shows Cover 1.

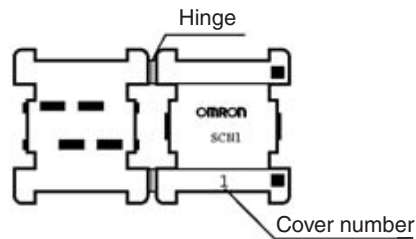

The following diagram shows the contact block.

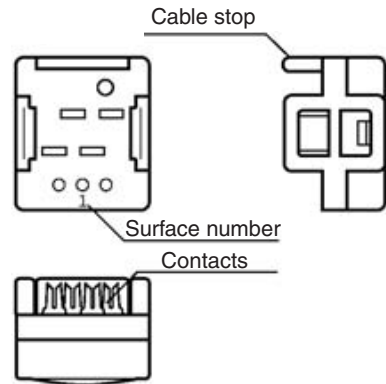

Installation Procedure

Use the following procedure to attach a Connector Terminator to the communications cable.

The following procedure is an example to connect a Connector Terminator to the main cable. The same procedure will apply even if the main line does not need to be distinguished from the branch lines.

- 1,2,3... 1. Make a perpendicular cut in the cable being used as the main line (the main cable). The cable will not fit in the connector properly if the cut is not straight and perpendicular.

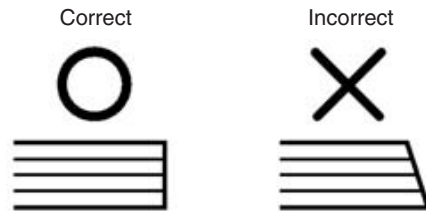

2. Snap Cover 1 onto the main cable. Make sure that the hook locks into place.

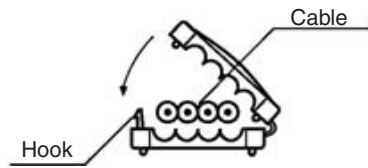

3. Line up the end of Cover 1 with the end of the main cable.

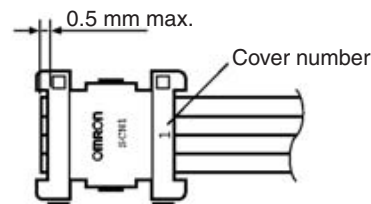

4. Position Cover 1 onto Surface 1 of the contact block (the side with the cable stop).

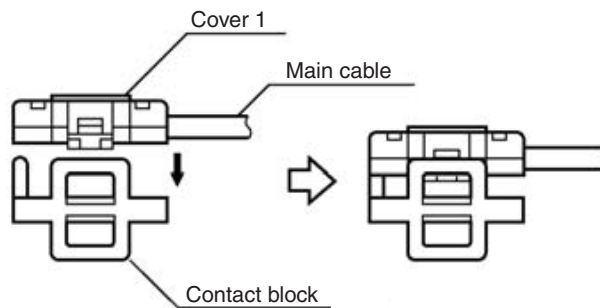

5. Make sure that the cable has been inserted all the way to the contact block's cable stop.
6. Use a tool such as pliers to compress Cover 1 and the contact block together.

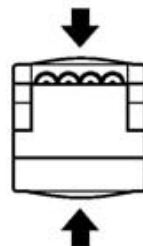

⚠ Caution Always align the tool with the centers of the Covers and contact block to prevent any bending or distortion when the connector is compressed. Uneven compression can prevent proper communications.

7. Check the assembled connector from the side and make sure that the locks are completely engaged, as shown in the following diagram.

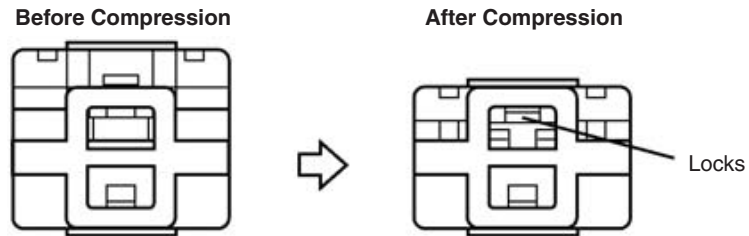

3-3 VCTF Cable Assembly

This section explains how to assemble VCTF cable components.

Commercially available 4-conductor VCTF cable and 2-conductor VCTF cable can be used as communications cable in CompoBus/S Systems.

- Note**
1. Lay the communications cables separately from high-voltage lines and power lines to prevent noise interference.
 2. This section does not provide information on how to process shielded connectors (i.e., Round Water-resistant Connectors or Sensor I/O Connectors). Refer to the *Sensor Catalog* for information on how to process these connectors.
 3. When using commercially available VCTF cable, determine which signal wires will be used for the BD H, BD L, BS+, and BS- signals.
 4. When connecting 4-conductor VCTF cable to an assembly connector, check that the conductors and signals are connected in the following patterns.

Conductor color	Signal combination			
	Pattern 1	Pattern 2	Pattern 3	Pattern 4
White	BD H	BS+	BS-	BD L
Red	BS+	BS-	BD L	BD H
Green	BS-	BD L	BD H	BS+
Black	BD L	BD H	BS+	BS-

3-3-1 Branching and Extending VCTF Cable

Use one of the following methods to branch or extend the VCTF cable.

- Commercially available relay terminal block (4-conductor/2-conductor VCTF cable branch or extension)
- T-joint or Combination Connector (4-conductor VCTF cable branch or extension)

Branching or Extension Using Relay Terminal Block

Install crimp terminals on each signal wire of the VCTF cable, and connect the two-wire cable (for extension) or three-wire cable (for branching) to a commercially available relay terminal block. Use crimp terminals on the signal wires that match the terminal block being used.

- Note**
1. Check that the signal wires are connected correctly. The Slave may be damaged if the signal wires, particularly those for the power supply, are connected to signal wires other than those specified.

2. Tighten the terminal block screws to a tightening torque that meets the terminal block specifications.

Example: Branching 2-Conductor VCTF Cable

Use a commercially available relay terminal block (a terminal block where the terminals facing each other are connected internally), and branch the cables as shown in the following diagram.

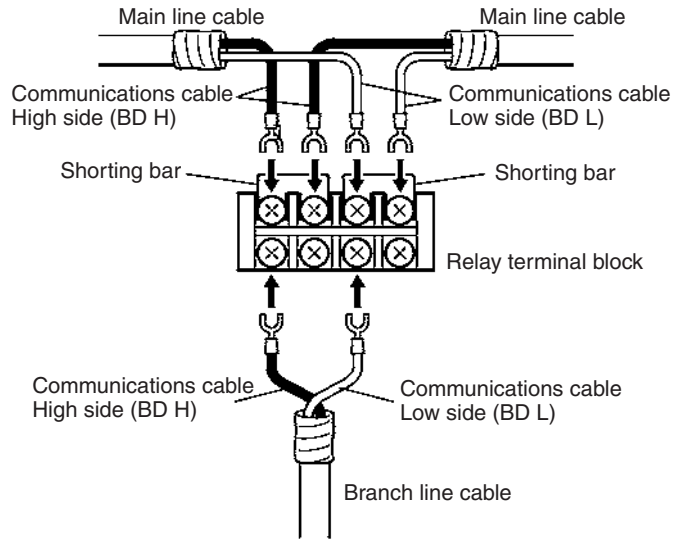

Branching or Extension Using T-joint Combination Connectors

When 4-conductor VCTF cable is used in locations that require water resistance, use XS2R-D427-5 T-joint Connectors or XS2C-D4□ or XS2G-D4□□ Combination Connectors that are specially designed for CompoBus/S Systems.

- Note**
1. Connectors with cables specially for CompoBus/S Systems are also available.
 2. For details on T-joint connectors, cable connectors, and connectors with cables, refer to *1-3-4 Connectors/Terminal Blocks*.

Example: Branching 4-Conductor VCTF Cable Using T-joint

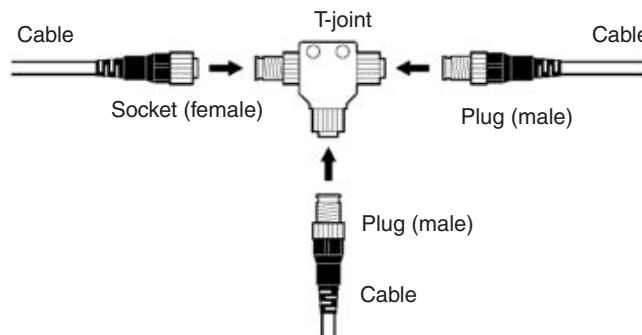

3-3-2 Installing Terminators

Use a Terminal-block Terminator or Shield Terminator as the terminator on the VCTF cable.

- Note** Refer to *1-3-4 Connectors/Terminal Blocks* for details on Terminal-block terminators, T-joints, and Connectors.

Terminal-block Terminators

When the VCTF cable is connected to an SRS1-T Terminal-block Terminator, use crimp terminals on each of the BD H and BD L signal wires, and connect them to each terminal. The signal wires can be connected to any of the terminals.

- Note**
1. Do not connect both signal wires to a single terminal.
 2. When connecting the communications power supply using Special Flat Cable or 4-conductor VCTF cable, insulate the BD+ and BS– power supply cables.
Tighten the terminal screws to the specified tightening torque (0.3 to 0.5 N·m).
 3. When connecting Terminal-block Terminators to VCTF cables, use the same crimp terminals as those used to connect the communications cables to the Slaves. (Refer to 3-4 Master/Slave Connecting Cables.)

Shield Terminators

When using 4-conductor VCTF cable, terminators can be connected by connecting an SRS2-1 Shield Terminator to the T-joint.

- Note** The SRS2-1 Shield Connector has a male plug. Connect it to the female socket connector of the T-joint.

3-4 Master/Slave Connecting Cables

This section describes the methods used for connecting communications cables to each device and installing connectors on the Connector Terminal and Sensor Terminal cables.

3-4-1 Crimp Terminal Installation

Attach crimp terminals to the ends of the communications cable when connecting the cable to a Master, Slave, Terminal-block Terminator, or commercially available terminal block.

-  **Caution** Do not connect bare signal wires to the terminals since the wires could short and damage the Unit to which they are connected.

- Note** Do not strip too much insulation from the wires when preparing the cable for the crimp terminals. Cover the shaft of the terminal connector and the end of the wire with electrical tape or heat-shrinking tube.

Master or Slave

When connecting communications cable (VCTF cable or Special Flat Cable) to a Master or Slave, attach an M3 crimp terminal like those shown below to each signal wire.

M3 Terminals for the Master Unit (Except CJ Series)



Recommended terminal	Comment
Nippon Crimp Terminal 1.25-N3A	Forked terminal
Molex Y1.25-3.5L	Forked terminal

- Note** Refer to 4-3-3 Wiring and Installing Communications Cables for details on crimp terminals used for connecting CJ-series Master Units.

M3 Terminals for Slave Units



Recommended terminal (standard JIS part numbers)
RAV1.25-3
RAP1.25-3

3-4-2 Master and Slave Terminal Connections

When connecting the communications cable to the terminals of a Master node or those of a Slave node, connect the BD H signal wire to the BD H terminal and the BD L signal wire to the BD L terminal.

When supplying power to the Slave's communications power supply, connect the BS+ wire to the BS+ terminal and the BS- wire to the BS- terminal. The following diagram shows the multi-drop connection method.

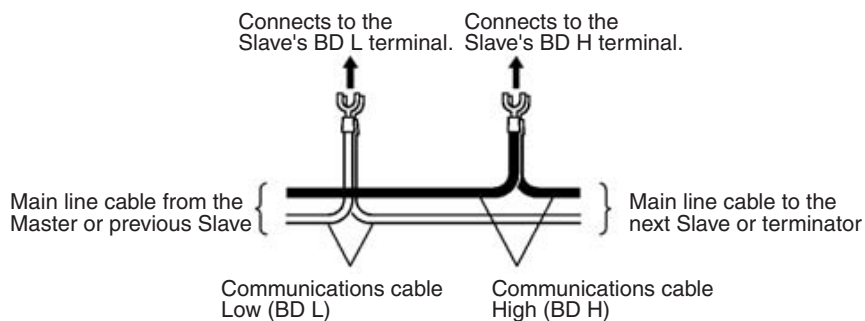

⚠ Caution Do not mix up the wires when connecting the communications cable. In particular, the Slave might be damaged if the power wires are connected to the wrong terminals.

When power is being supplied through Special Flat Cable but some Slaves are being supplied from another source, always insulate the BS+ and BS- wires.

Tighten the terminal screws to the specified tightening torque (0.3 to 0.5 N·m).

3-4-3 Cable Connector Wiring and Assembly

When using the Slaves shown in the following table, attach the special OMRON cable connectors to the cables of the sensors and other external devices.

Slave type	Model
Connector Terminals with Transistor Inputs	SRT2-VID08S (-1)
Connector Terminals with Transistor Outputs	SRT2-VOD08S (-1)
Sensor Terminals with Connector Outputs	SRT□-OD08S
Sensor Terminals	SRT□-ID08S SRT□-ND08S

Assembling the Cable Connectors

Use the following procedure to install the sensor’s cable into the cable connector that plugs into the Sensor Terminal. The following diagram shows the two parts of the cable connector: the connector plug and cover.

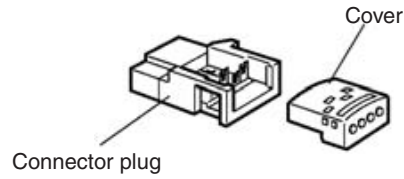

Cable Connector Model Numbers

There are two models of cable connectors available for different sized cable wires, as shown in the following table.

Model	Marking	Compatible cable wire size (cross-sectional area)
XS8A-0441	XS8-1	0.3 to 0.5 mm ²
XS8A-0442	XS8-2	0.14 to 0.2 mm ²

Make sure that the sensor cable’s wire size is compatible the cable connector being used. The cable connector’s marking is found on the connector plug, as shown in the following diagram.

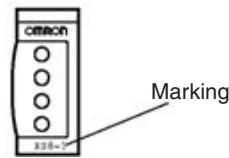

Sensor Cable Preparation

Sensor cables are usually stripped to semi-strip or strip specifications, but OMRON cable connectors cannot be attached when the cable is stripped in these ways.

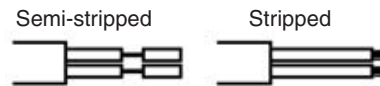

To prepare the cable for an OMRON cable connector, cut the tip and strip the cable insulation but not the wire insulation, as shown in the following diagram.

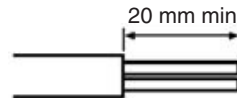

Inserting Wires into the Cover

When connecting the Sensor, match the terminal numbers marked on the connector cover with the colors of the sensor wires as shown in the following table.

Sensor terminal	Sensor type	Terminal number			
		1	2	3	4
SRT2-VID08S	3-wire sensor (without self-diagnostic output function)	Black (white) (Connect to 1 or 2)		Brown (red)	Blue (black)
	2-wire sensor (without self-diagnostic output function)	Brown (white) (Connect to 1 or 2)		---	Blue (black)

Sensor terminal	Sensor type	Terminal number			
		1	2	3	4
SRT2-VID08S-1	3-wire sensor (without self-diagnostic output function)	Black (white) (Connect to 1 or 2)		Brown (red)	Blue (black)
	2-wire sensor (without self-diagnostic output function)	Blue (black) (Connect to 1 or 2)		Brown (white)	---

Sensor terminal	Sensor type	Terminal number			
		1	2	3	4
SRT□-ID08S	3-wire sensor (without self-diagnostic output function)	Black (white)	---	Brown (red)	Blue (black)
	2-wire sensor (without self-diagnostic output function)	Brown (white)	---	---	Blue (black)
SRT□-ND08S	Sensor with teaching function or external diagnostic function	Black (white)	Pink (gray)	Brown (red)	Blue (black)
	Sensor with bank switching function	Black	Purple	Brown	Blue

Note In accordance with the changes in the standards for photoelectric sensors and proximity sensors, wire colors have been changed. Colors in parentheses are the old wire colors.

When connecting an output device, match the terminal numbers marked on the connector cover with the signal wires of the output device as shown in the following table.

Sensor terminal	Terminal number			
	1	2	3	4
SRT2-VOD08S	Yes (Connect to 1 or 2)		Yes	---
SRT2-VOID08S-1	Yes (Connect to 1 or 2)		---	Yes
SRT□-OD08S	Yes	---	Yes (Connect to 3 or 4)	

Insert the wire all the way into the cover's hole until it touches.

Connector Assembly

Use the following procedure to assemble the cable connector.

- 1,2,3...**
1. Check the wire colors and make sure that the sensor's wires are aligned with the correct terminal numbers. (The cover is semi-transparent, so the wire colors will be visible through the cover.)
 2. Fit the cover (with wires inserted) into the connector plug, as shown in the following diagram.

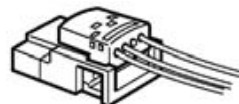

3. Use a tool such as pliers to press the cover all the way into the connector plug. Always align the tool with the center of the cover so it does not tilt,

and press the cover straight into the connector plug. There should not be any gap between the cover and plug.

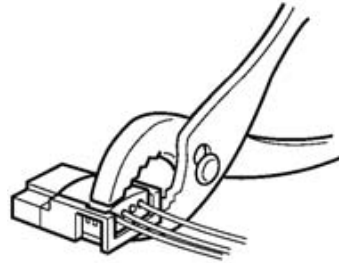

Inserting and Removing Cable Connectors

The sensor cable can be inserted into the Sensor Terminal once the cable connector has been attached.

Inserting the Cable Connector

Position the cable connector so that Terminal 1 faces you and push the connector into the Sensor Terminal until it clicks into place.

Removing the Cable Connector

To remove the cable connector, first pull out the lock lever and then remove the cable connector, as shown in the following diagram.

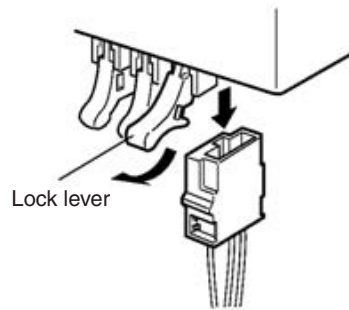

3-5 Operations Checklist

Go through the items in the following checklist before turning ON the Units in the CompoBus/S System. All of the checks should be answered “Yes.”

Item		Check	Answer
CS-series, C200HX/C200HG/C200HE-(Z)E, and C200HS Master Units	Switch settings	Has the Master's Special I/O Unit unit number been set? (Refer to 4-1-2 Switch Settings for details.)	Yes No
		Has the node number been set with pin 1 of the DIP switch? (Refer to 4-1-2 Switch Settings for details.)	Yes No
		Has the communications mode been set with pin 2 of the DIP switch? (Refer to 4-1-2 Switch Settings for details.)	Yes No
		Are pins 3 and 4 of the DIP switch all set to OFF?	Yes No

Item		Check	Answer
CS-series Master Units	Switch settings	Has the Master's Special I/O Unit number been set? (Refer to 4-2-2 <i>Switch Settings</i> for details.)	Yes No
		Has the node number been set with pin 1 of the DIP switch? (Refer to 4-2-2 <i>Switch Settings</i> for details.)	Yes No
		Has the communications mode been set with pin 2 of the DIP switch? (Refer to 4-2-2 <i>Switch Settings</i> for details.)	Yes No
		Has the communications stop mode been set with pin 3 of the DIP switch? (Refer to 4-2-2 <i>Switch Settings</i> for details.)	Yes No
		Has the Slave registration function been set with pin 4 of the DIP switch? (If the Slave registration function is used, the CPU Unit's DM Area must also be set.) (Refer to 4-2-2 <i>Switch Settings</i> for details.)	Yes No
CJ-series Master Units	Switch settings	Has the Master's Special I/O Unit number been set? (Refer to 4-3-2 <i>Switch Settings</i> for details.)	Yes No
		Has the node number been set with pin 1 of the DIP switch? (Refer to 4-3-2 <i>Switch Settings</i> for details.)	Yes No
		Has the communications mode been set with pin 2 of the DIP switch? (Refer to 4-3-2 <i>Switch Settings</i> for details.)	Yes No
		Has the communications stop mode been set with pin 3 of the DIP switch? (Refer to 4-3-2 <i>Switch Settings</i> for details.)	Yes No
		Has the Slave registration function been set with pin 4 of the DIP switch? (If the Slave registration function is used, the CPU Unit's DM Area must also be set.) (Refer to 4-3-2 <i>Switch Settings</i> for details.)	Yes No
CQM1 Master Units	Switch settings	Has the PLC word allocation (DIP switch pins 1 and 2) been set? (Refer to 4-4-2 <i>Switch Settings</i> for details.)	Yes No
		Has the number of points/node number setting (DIP switch pin 3) been set? (Refer to 4-4-2 <i>Switch Settings</i> for details.)	Yes No
		Has the communications mode been set with pin 4 of the DIP switch? (Refer to 4-4-2 <i>Switch Settings</i> for details.)	Yes No
		Are pins 5 and 6 of the DIP switch all set to OFF?	Yes No
Slaves	Switch settings	Has the node number been set? (Refer to SECTION 5 <i>Slave Specifications and Operations</i> for details.)	Yes No
		Has the communications mode been set? (Refer to SECTION 5 <i>Slave Specifications and Operations</i> for details.)	Yes No
		Is the Slave's node number unique (not allocated to another Slave)?	Yes No
		Have other settings besides the CompoBus/S settings, such as the "hold/clear outputs for communications error" setting, been set? (Refer to SECTION 5 <i>Slave Specifications and Operations</i> for details.)	Yes No

Item		Check	Answer
Wiring	Master	Is the Master Unit connected at the end of the main line when the main line needs to be distinguished from the branch lines.?	Yes No
		Is the cable connected to the Master correctly? (Refer to 3-4 Master/Slave Connecting Cables for details.)	Yes No
		With CQM1 Masters, has the alarm output terminal been wired? (Refer to 6-4-2 Error Detection with the Alarm Output (CQM1 Only) for details.)	Yes No
	Slave	Are the cables connected to the Slaves correctly? (Refer to 3-4 Master/Slave Connecting Cables for details.)	Yes No
		Is there just one Slave connected to each branch line when the main line needs to be distinguished from the branch lines? (Refer to 2-2-1 Main Line/Branch Line Connections for details.)	Yes No
	Terminator	Has just one terminator been connected at the end of the main line opposite the Master? (Refer to 2-2-3 Terminator Connection for details.)	Yes No
	Main line length	When the main line needs to be distinguished from the branch lines, is the length of the main line within specifications? (Refer to 2-2-2 Maximum Cable Length for details.)	Yes No
	Branch line lengths	When the main line needs to be distinguished from the branch lines, is the length of the each branch line within specifications? (Refer to 2-2-2 Maximum Cable Length for details.)	Yes No
	Total branch line length	When the main line needs to be distinguished from the branch lines, is the total length of the branch lines within specifications? (Refer to 2-2-2 Maximum Cable Length for details.)	Yes No
	Number of Slaves	Is the number of Slaves within the limit set on the Master? (Refer to SECTION 4 Master Unit Specifications and Operations for details.)	Yes No
		When using 4-conductor VCTF cable or Special Flat Cable, are the main line length and total branch line length of the system with a maximum of 16 Slaves within specifications? (Refer to 2-2-2 Maximum Cable Length for details.)	Yes No
	Cable	Has just one kind of cable (Special Flat Cable or VCTF cable) been used in the CompoBus/S System?	Yes No
		If Special Flat Cables are used for multiple CompoBus/S Systems, install the cables at least 5 mm apart from other Special Flat Cables.	Yes No
Noise	Is the wiring separated from any power/high-voltage lines?	Yes No	
Cable	2-conductor VCTF cable	Has 2-conductor (0.75 mm ²) cable been used?	Yes No
	4-conductor VCTF cable	Has 4-conductor (0.75mm ²) cable been used?	Yes No
		Has the 4-conductor cable power supply been used to supply power to the Slaves only (not for other purposes, such as I/O power supply)?	Yes No
	Special Flat Cable	Has the Special Flat Cable power supply been used to supply power to the Slaves only (not for other purposes, such as I/O power supply)?	Yes No
Power supply	4-conductor VCTF Cable, Special Flat Cable	Does the power supply configuration match the plan? (Refer to 2-3 Supplying Power to the Slaves for details.)	Yes No
		With local and dual power supply Slaves, is there a separate power supply for the I/O? (Refer to 2-3 Supplying Power to the Slaves for details.)	Yes No
	2-conductor VCFF cable	Have the Slaves been wired correctly? (The Units can be damaged if the power supply is connected to the communications terminals.) (Refer to 2-3 Supplying Power to the Slaves for details.)	Yes No

SECTION 4

Master Unit Specifications and Operations

This section provides information on the specifications and functions of each Master Unit, including details on switch settings and allocation of Slave I/O.

4-1	C200HW-SRM21-V1 Master Unit for CS-series, C200HX/C200HG/C200HE-(Z)E, and C200HS PLCs	74
4-1-1	Specifications and Part Names	74
4-1-2	Switch Settings	76
4-1-3	I/O Allocations in CS-series, C200HX/C200HG/C200HE-(Z)E, and C200HS PLCs	78
4-1-4	Data Areas in the PLC	85
4-2	CS1W-SRM21 Master Unit for CS-series PLCs	88
4-2-1	Specifications and Part Names	88
4-2-2	Switch Settings	90
4-2-3	I/O Allocations	92
4-2-4	Slave Registration Function and Communications Stop Mode	98
4-2-5	Allocations for Master Unit in PLC	103
4-3	CJ1W-SRM21 Master Unit for CJ-series PLCs	104
4-3-1	Specifications and Part Names	104
4-3-2	Switch Settings	107
4-3-3	Wiring and Installing Communications Cables	109
4-3-4	I/O Allocations	114
4-3-5	Slave Registration Function and Communications Stop Mode	120
4-3-6	Allocations for Master Unit in PLC	125
4-4	CQM1-SRM21-V1 Master Unit for CQM1 PLCs	126
4-4-1	Specifications and Part Names	126
4-4-2	Switch Settings	129
4-4-3	I/O Allocations in CQM1 PLCs	130
4-5	SRM1-C0□-V2 Master Control Units	136
4-5-1	Specifications and Part Names	136
4-5-2	Settings	140
4-6	CPM2C-S Series CPM2C-S□□□C (-DRT)	140
4-6-1	Specifications and Part Names	141
4-6-2	Settings	144

4-1 C200HW-SRM21-V1 Master Unit for CS-series, C200HX/C200HG/C200HE-(Z)E, and C200HS PLCs

4-1-1 Specifications and Part Names

CS-series, C200HX/C200HG/C200HE-(Z)E, and C200HS PLCs use the C200HW-SRM21-V1 Master Unit.

Specifications

General Specifications

General specifications conform to those of the CS-series, C200HX/C200HG/C200HE-(Z)E, and C200HS PLCs.

Performance Specifications

Item	Specifications	
Model	C200HW-SRM21-V1	
Unit classification	Special I/O Unit	
Internal current consumption	5 V DC, 150 mA max.	
Weight	200 g max.	
Max. number of Masters	10 or 16 Units (See note.)	5 or 8 Units (See note.)
Master Unit mounting location	Can be mounted on the CPU Backplane or Expansion I/O Backplane. Can't be mounted on a SYSMAC BUS Slave (RT).	
Max. number of I/O points per Master	128 points (64 inputs/64 outputs)	256 points (128 inputs/128 outputs)
Number of points per node number	8-point mode	
Number of usable node numbers per Master	IN0 to IN7 and OUT0 to OUT7 (up to 16 Units can be connected)	IN0 to IN15 and OUT0 to OUT15 (up to 32 Units can be connected)

Note The following table shows the maximum number of Master Units that can be connected and the node number settings for each Master according to the CPU Unit to which it is mounted.

CPU Unit	Number of connectable Master Units	
	IN0 to IN7, OUT0 to OUT7	IN0 to IN15, OUT0 to OUT15
C200HX-CPU3□/4□-(Z)E C200HG-CPU3□/4□-(Z)E C200HE, and C200HS	10 Units	5 Units
C200HX-CPU5□/6□/8□-(Z)E C200HG-CPU5□/6□-(Z)E, and CS	16 Units	8 Units

Dimensions

The following diagram shows the dimensions of the C200HW-SRM21-V1 Master Unit. All dimensions are in mm.

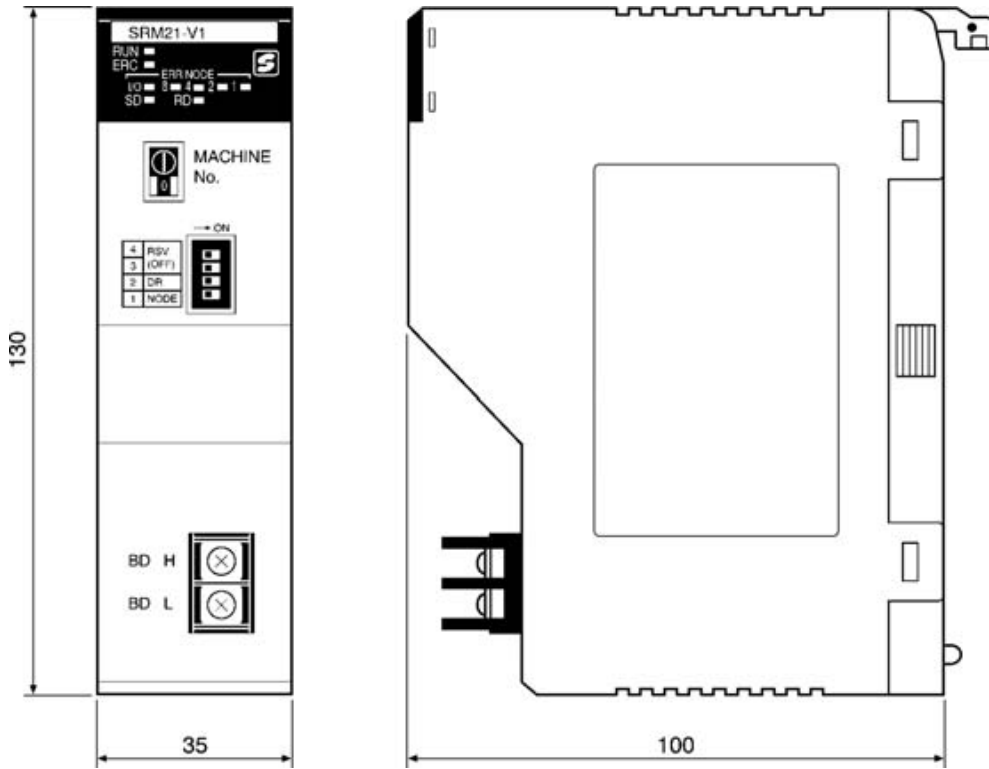

Note Refer to the *CS-series Operation Manual*, *C200HX/C200HG/C200HE-(Z)E Operation Manual*, or *C200HS Operation Manual* for details on the dimensions when the Master Unit is installed on the PLC's Backplane.

Master Unit Components

The following diagram shows the main components of the C200HW-SRM21-V1 Master Unit. The functions of these components are described below.

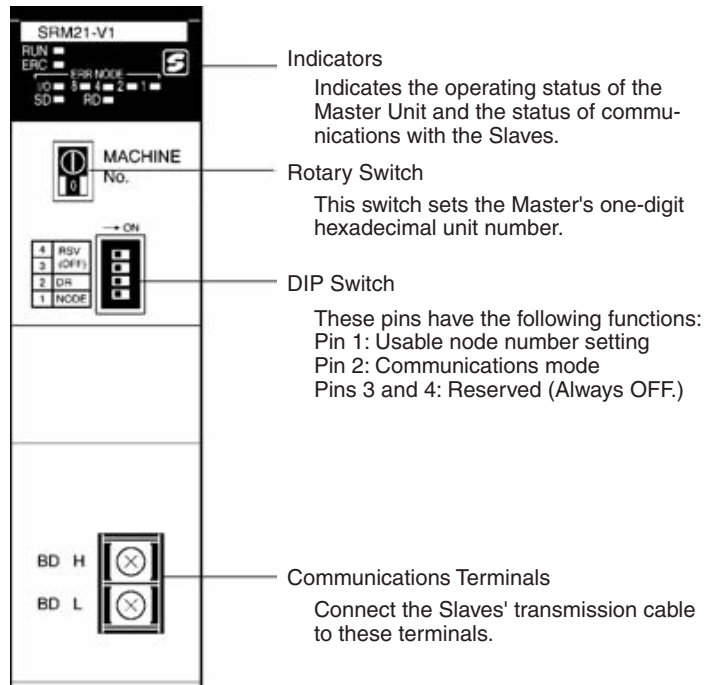

Indicators

The following table shows the meaning of the indicators.

Indicator	Status	Meaning
RUN (green)	ON	The Unit is operating normally.
	OFF	Indicates one of the following conditions: The power is OFF, there is an I/O setting error, the CPU Unit is in standby status, or there is a unit number setting error.
SD (yellow)	ON	Data is being transmitted.
	OFF	Data is not being transmitted.
RD (yellow)	ON	Data is being received.
	OFF	Data is not being received.
ERC (red)	ON	A Slave has been withdrawn from communications. (Communications error)
	OFF	The Slaves are communicating normally.
IN/OUT (red)	ON	An error has occurred with an Output Slave.
	OFF	An error has occurred with an Input Slave or all Slaves are operating normally.
8421 (red)	ON/OFF	These indicators represent the four-digit binary slave number of the Slave in which the error occurred.

4-1-2 Switch Settings

Rotary Switch

The Master Unit's unit number (Special I/O Unit's unit number) is set with the rotary switch on the front of the Unit.



The highest possible unit number depends on the PLC model and the usable node number setting set with pin 1 of the DIP switch.

CPU Unit	Number of usable Master Units	Usable node number setting (with DIP switch)	Unit number setting range
CS1	16 (allocated words for 1 Special I/O Unit (i.e., 10 words))	IN0 to IN7 and OUT0 to OUT7	0 to F
	8 (allocated words for 2 Special I/O Units (i.e., 20 words))	IN0 to IN15 and OUT0 to OUT15	0 to E
C200HX-CPU3□-(Z)E /-CPU4□-(Z)E, C200HG- CPU3□-(Z)E /-CPU4□-(Z)E, All C200HE/HS PLCs	10 (allocated words for 1 Special I/O Unit (i.e., 10 words))	IN0 to IN7 and OUT0 to OUT7	0 to 9
	5 (allocated words for 2 Special I/O Units (i.e., 20 words))	IN0 to IN15 and OUT0 to OUT15	0 to 8
C200HX/HG-CPU5□-(Z)E/ CPU6□-(Z)E/CPU8□-(Z)E	16 (allocated words for 1 Special I/O Unit (i.e., 10 words))	IN0 to IN7 and OUT0 to OUT7	0 to 9, A to F
	8 (allocated words for 2 Special I/O Units (i.e., 20 words))	IN0 to IN15 and OUT0 to OUT15	0 to 8, A to E

Any unit number in the ranges above can be set, as long as the same unit number has not been set on another Special I/O Unit mounted in the PLC. Set the unit number with a small flat-blade screwdriver, being careful not to damage the switch.

⚠ Caution Always turn OFF the PLC before changing the unit number setting.

- The Master Unit is shipped with the unit number set to 0.
- The unit number setting determines which words in the PLC's Special I/O Unit Area are allocated to the Master Unit. Refer to 4-1-3 I/O Allocations in CS-series, C200HX/C200HG/C200HE-(Z)E, and C200HS PLCs for details.
- The Master Unit is allocated twice as many words in the PLC's Special I/O Unit Area (the words for unit number set on the Master and the next unit number) when the usable node number setting is set to IN0 through IN15 and OUT0 through OUT15. In this case, neither the Master's unit number nor the next unit number can be used on another Special I/O Unit mounted in the PLC.
- If the same unit number is used for the Master and another Special I/O Unit, an I/O UNIT OVER error will occur in the PLC and it will not be possible to start up the CompoBus/S System.
- For the following PLCs, unit numbers A to F cannot be set:
C200HE, C200HS, C200HG-CPU33-(Z)E, C200HG-CPU43-(Z)E, C200HX-CPU34-(Z)E, and C200HX-CPU44-(Z)E

DIP Switch

The DIP switch is used to set the range of usable node numbers of Slaves and the communications mode.

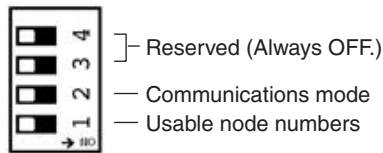

- Note**
1. Always turn the PLC OFF before changing the settings.
 2. Leave pins 3 and 4 set to OFF.

Set pin 1 of the DIP switch as shown in the following table.

Pin 1 setting	Usable node number setting
OFF	IN0 to IN7 and OUT0 to OUT7
ON	IN0 to IN15 and OUT0 to OUT15

Set pin 2 of the DIP switch as shown in the following table.

Pin 2 setting	Communications mode setting	Communications distance	Communications baud rate	Communications cycle time
OFF	High-speed Communications Mode	100 m max.	750 kbps	0.5 ms or 0.8 ms
ON	Long-distance Communications Mode	500 m max.	93.75 kbps	4.0 ms or 6.0 ms

- Note**
1. Make sure that the communications mode of the Master Unit matches that of all Slaves. If the CompoBus/S System contains a Slave whose communications mode does not agree with that of the Master Unit, the COMM indicator on that Slave will not light, and normal communications with that Slave will not be possible. Other Slaves will not be adversely affected. (In such cases, the COMM indicator on the Master Unit will light normally.) For information relating to the states of the Master Unit indicator, refer to 6-5-1 Indicators.
 2. When using an existing Master Unit model without V1, pin 2 must be set to OFF. Otherwise, normal communications may not be possible.

- The Master Unit is factory-set to OFF (for IN0 to IN7 and OUT0 to OUT7).
- The maximum number of Slaves setting affects both the total number of words allocated and the Slaves' communication cycle. Refer to 4-1-3 I/O Allocations in CS-series, C200HX/C200HG/C200HE-(Z)E, and C200HS PLCs for details.
- The Master Unit is allocated twice as many words in the PLC's Special I/O Unit Area (the words for unit number set on the Master and the next unit number) when the usable node number setting is set to IN0 to IN15 and OUT0 to OUT15. In this case, neither the Master's unit number nor the next unit number can be used on another Special I/O Unit mounted in the PLC.
- Pin 2 is factory-set to OFF (High-speed Communications Mode).
- The setting of pin 2 determines the communications distance, baud rate, and cycle time as shown in the above table.

4-1-3 I/O Allocations in CS-series, C200HX/C200HG/C200HE-(Z)E, and C200HS PLCs

In CS-series, C200HX/C200HG/C200HE-(Z)E, and C200HS PLCs, the Master Unit is treated as a Special I/O Unit, so the Slave's I/O data and status information are stored in the sections of the PLC's data areas which are allocated to Special I/O Units.

Allocations and Master Unit Settings

The following settings affect I/O allocations to Slaves in the Master Units used with CS-series, C200HX/C200HG/C200HE-(Z)E, and C200HS PLCs.

Setting at Master Unit	Status	Affect on allocation
Usable node number settings (DIP switch pin 1)	OFF	Uses 10 words (for one unit number) from the Special I/O Unit Area as follows: Output: 4 words, input: 4 words, status: 2 words.
	ON	Uses 20 words (for two unit numbers) from the Special I/O Unit Area as follows: Output: 8 words, input: 8 words, status: 4 words.
Unit number setting (rotary switch)	n	First word of the area used in the Special I/O Unit Area CS Series $2000 + n \times 10$ C200HX/HG/HE/HS For $0 \leq n \leq 9$: $100 + n \times 10$ For $10 \leq n \leq 15$ (A to F): $400 + (n - 10) \times 10$

Slave Allocations

Slaves are allocated words in the Special I/O Unit Area as described next. In CompoBus/S Systems, node numbers of Input Slaves and Output Slaves are treated separately so the same node number can be allocated.

I/O Allocations when Pin 1 Is OFF

When pin 1 is OFF and node addresses IN0 to IN7 and OUT0 to OUT7 (up to 64 inputs/64 outputs) are used, words are allocated to the Slaves for each node number as shown in the following diagrams.

CS-series PLCs

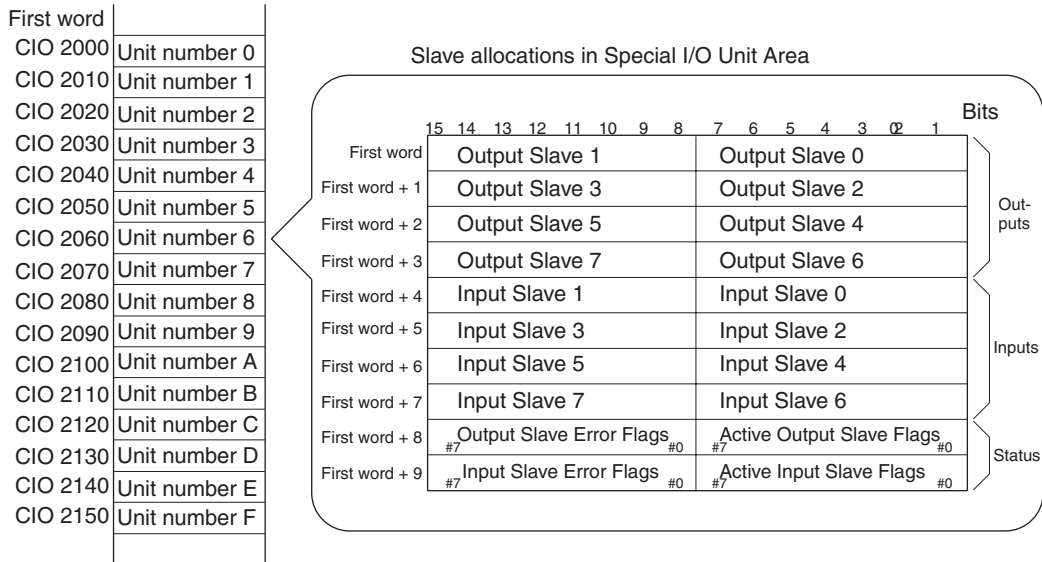

C200HX/C200HG/C200HE-(Z)E, and C200HS PLCs

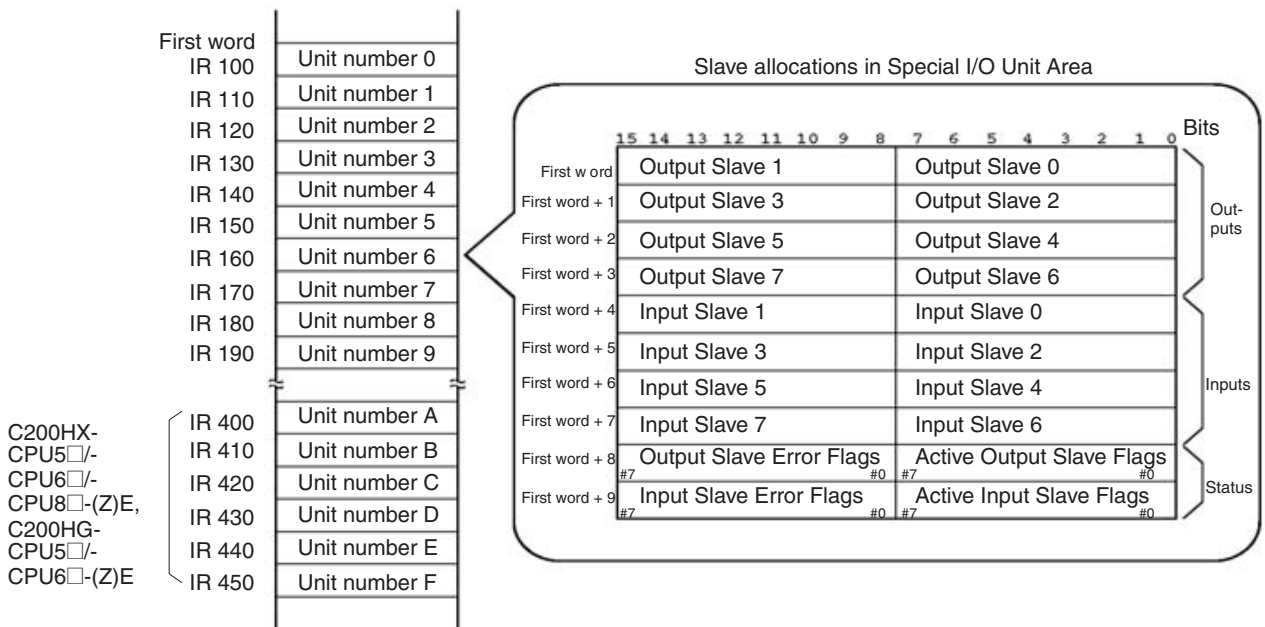

I/O Allocations when Pin 1 is ON

When pin 1 is ON and node addresses IN0 to IN15 and OUT0 to OUT15 (128 inputs/128 outputs max) are used, words are allocated to the Slaves for each node number as shown in the following diagrams.

CS-series PLCs

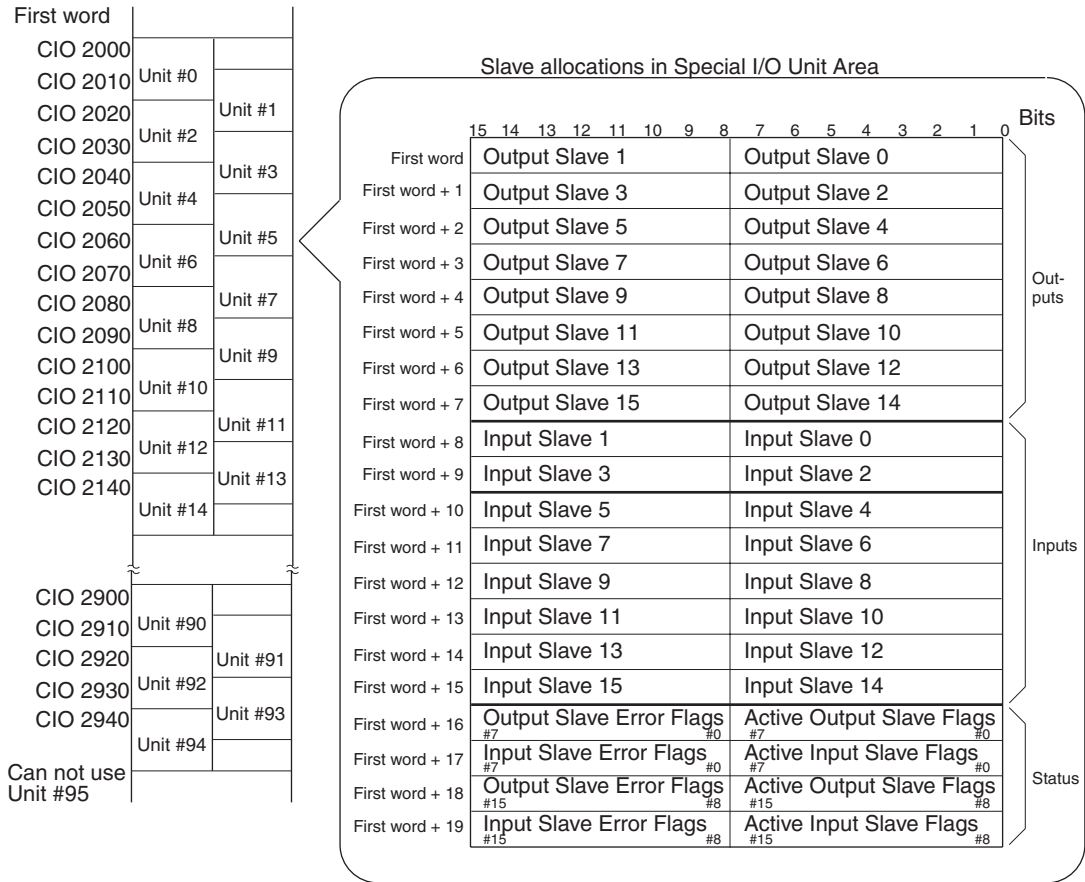

C200HX/C200HG/C200HE-(Z)E, and C200HS PLCs

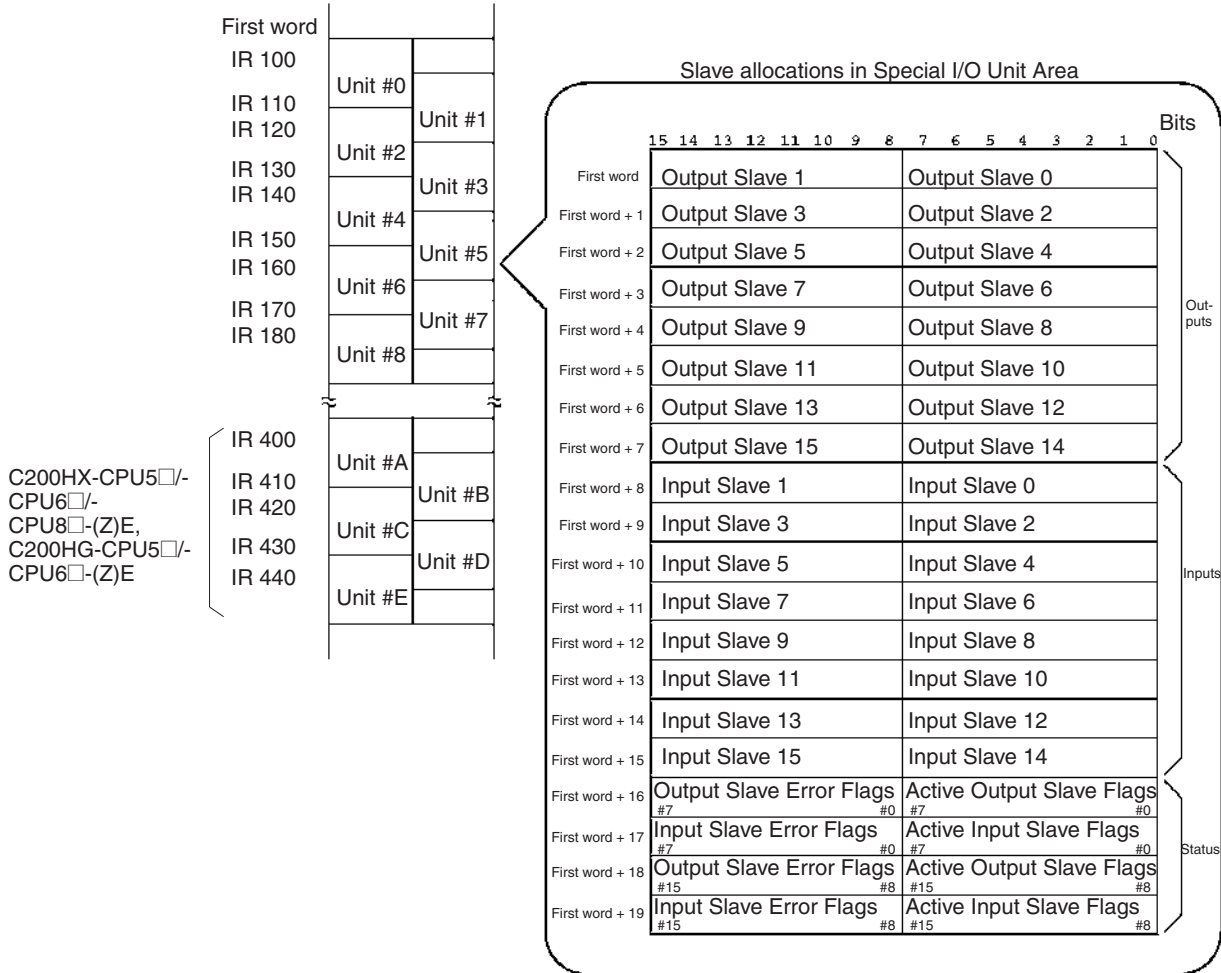

Slave I/O and Corresponding Allocations

Slave with 8 Inputs or 8 Outputs

The Slave is treated as one node number for output or input.

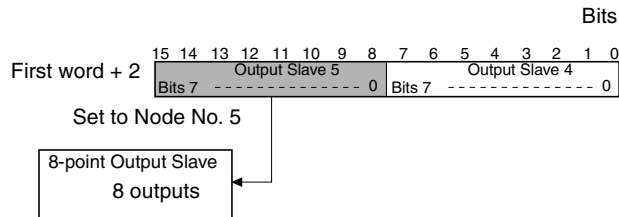

Slave with 16 Inputs or 16 Outputs

The Slave is treated as two node numbers for output or input, and allocated in the same words as follows:

- When an odd node number has been set:
Uses node number setting – 1 and node number setting
- When an even node number has been set:
Uses node number setting and node number setting + 1.

Example: When a 16-point Output Slave set as node number 5, the areas for Output Slaves 4 and 5 are used. Other Output Slaves cannot use the area allocated for Output Slave 4.

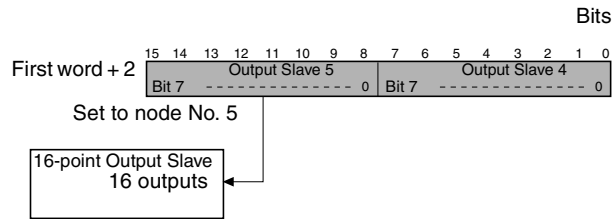

Slave with Mixed I/O (8 Inputs and 8 Outputs)

Slaves that have both outputs and inputs are also assigned a single node number, so the same node number is used for both outputs and inputs.

Example: When a Slave with 8 inputs and 8 outputs set as node number 2, the area for node number 2 outputs and inputs is used.

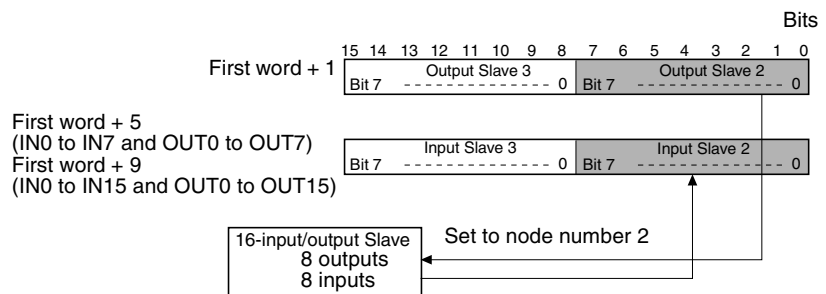

Slave with 4 Outputs or 4 Inputs

The Slave is treated as one node number for output or input. The Slave uses the rightmost 4 bits only, however, of the area allocated for one node number. (The leftmost 4 bits cannot be used by another Slave.)

- When an odd node number has been set:
Bits 8 to 11 are used and bits 12 to 15 are not used.
- When an even node number has been set:
Bits 0 to 3 are used and bits 4 to 7 are not used.

Example: When a Slave with 4 inputs is set as node number 7, the Slave is allocated the rightmost 4 bits (bits 8 to 11) in the area assigned for input node number 7.

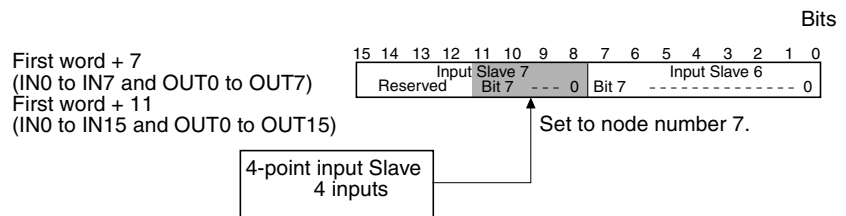

Slave with Mixed I/O (4 Outputs and 4 Inputs)

Slaves that have both outputs and inputs are also assigned a single node number, so the same node number is used for both outputs and inputs. The Slave uses the rightmost 4 bits only, however, of the area allocated for one node number. (The leftmost 4 bits cannot be used by another Slave.)

- When an odd node number has been set:
Bits 8 to 11 are used and bits 12 to 15 are not used.

- When an even node number has been set:
Bits 0 to 3 are used and bits 4 to 7 are not used.

Example: When a Slave with 4 outputs and 4 inputs is set to node number 2, the rightmost 4 bits (bits 0 to 3) of the area for node number 2 for both output and input are used.

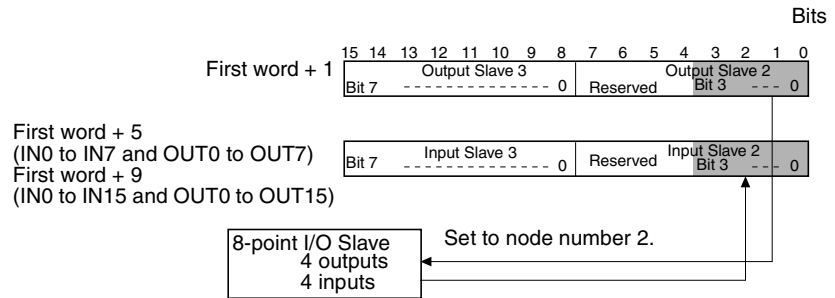

Slave with 32 Outputs or 32 Inputs

The Slave is treated as four node numbers for output or input and is allocated 2 consecutive words, as follows:

- When an odd node number has been set:
Uses (node number setting – 1) to (node number setting + 2)
- When an even node number has been set:
Uses (node number setting) to (node number setting + 3).

Example: When a Slave with 32 outputs is set to node number 1, it uses the area assigned for Output Slave 0 to Output Slave 3. The area for Output Slave 0, 2, and 3 cannot be used for another Output Slave.

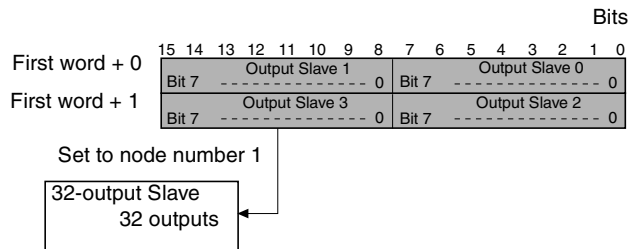

Slave with Mixed I/O (16 Outputs and 16 Inputs)

Slaves that have both outputs and inputs are also assigned a single node number, so the same node number is used for both outputs and inputs, and each is regarded as two node numbers. Outputs and inputs are allocated to the same words, as follows:

- When an odd node number has been set:
Uses (node number setting – 1) and (node number setting)
- When an even node number has been set:
Uses (node number setting) and (node number setting + 1).

- Example: When a Slave with 16 inputs and 16 outputs is set to node number 3, it uses Output Slave 2 and 3, and Input Slave 2 and 3. Output Slave 2 and Input Slave 2 cannot be used by other Slaves.

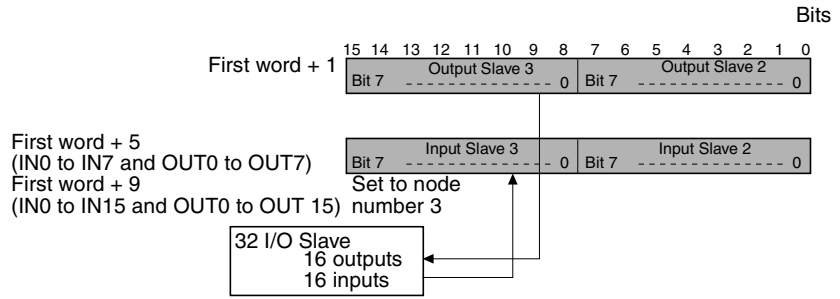

An Analog Terminal uses 64, 48, 32, or 16 points. I/O allocations are shown in the following table.

Number of points allocated	Node number setting	Node numbers used
64 points SRT2-AD04: 4 inputs	Odd number	Node number setting – 1 to node number setting + 6
	Even number	Node number setting to node number setting + 7
48 points SRT2-AD04: 3 inputs	Odd number	Node number setting – 1 to node number setting + 4
	Even number	Node number setting to node number setting + 5
32 points SRT2-AD04: 2 inputs SRT2-DA02: 2 outputs	Odd number	Node number setting – 1 to node number setting + 2
	Even number	Node number setting to node number setting + 3
16 points SRT2-AD04: 1 input SRT2-DA02: 1 output	Odd number	Node number setting – 1 to node number setting
	Even number	Node number setting to node number setting + 1

Do not allow allocations for the node numbers that are actually used to extend beyond the words allocated to the Master Unit. Participation in communications will not be possible and the COMM indicator will turn OFF if the words allocated to the Master are exceeded for either inputs or outputs.

Status Flag Functions

The functions of the flags in the status area are described below.

- Active Output Slave Flags

These flags indicate which Output Slaves (0 to 15) are active nodes in the system. When the corresponding flag is ON, the Slave is an active node. All of these flags are reset when the power is turned ON or operation is restarted.

 - 0 (OFF): No communications participation
The node hasn't participated in communications even once.
 - 1 (ON): Communications participation
The flag won't change even if the node is withdrawn from the system.
- Active Input Slave Flags

These flags indicate which Input Slaves (0 to 15) are active nodes in the system. When the corresponding flag is ON, the Slave is an active node. All of these flags are reset when the power is turned ON or operation is restarted.

 - 0 (OFF): No communications participation
The node hasn't participated in communications even once.

1 (ON): Communications participation

The flag won't change even if the node is withdrawn from the system.

- Output Slave Error Flags

These flags indicate the communications status of the Output Slaves (0 to 15). All of these flags are reset when the power is turned ON or operation is restarted.

0 (OFF): Communications normal or inactive node

1 (ON): Withdrawn from communications (communications error)

- Input Slave Error Flags

These flags indicate the communications status of the Input Slaves (0 to 15). All of these flags are reset when the power is turned ON or operation is restarted.

0 (OFF): Communications normal or inactive node

1 (ON): Withdrawn from communications (communications error)

Note When the CompoBus/S System starts up, inputs from Input Slaves and outputs to Output Slaves become effective when the Active Slave Flag for the Slave is turned ON. It is recommended to write a ladder program that verifies that the Slave's Active Slave Flag is ON and its Error Flag is OFF before transmitting or receiving I/O data.

4-1-4 Data Areas in the PLC

The following table shows the data areas in the CPU that are used by the Master Unit.

CS-series PLCs

Data Area	Bit(s)	Name	Function
Auxiliary Area (A)	A33000 to A33015	Special I/O Unit Restarting Flags	These flags are turned ON while a Special I/O Unit is restarting. Each bit corresponds to the Unit with the same unit number.
	A40113	Dual Number Use Error Flag (Fatal Error)	This flag is turned ON in the following situations: When the same unit number has been set on more than one CS1 CPU Bus Unit. When the same unit number has been set on more than one Special I/O Unit. When the same word is allocated more than once for Basic I/O Units.
	A40206	Special I/O Unit Error Flag	This flag is turned ON when the same unit number has been set on more than one Special I/O Unit, or when an error has occurred during data transfer between the PLC and the Special I/O Unit. The unit number of the Unit is written to word A418.
	A41100 to A41115	Special I/O Unit Number Duplication Flags	These flags are turned ON when the same unit number has been set on more than one Special I/O Unit (i.e., when A40113 is ON). Each bit corresponds to the Unit with the same unit number.
	A41800 to A41815	Special I/O Unit Error Flags	These flags are turned ON when the same unit number has been set on more than one Special I/O Unit, or when an error has occurred during data transfer between the PLC and the Special I/O Unit. Each bit corresponds to the Unit with the same unit number.
	A50200 to A50215	Special I/O Unit Restart Bits	Turn the corresponding bit ON and then OFF to restart a Special I/O Unit. Each bit corresponds to the Unit with the same unit number.
PLC Setup	22600 to 22615	Special I/O Unit Refresh Disable Bits	Turn the corresponding bit ON to disable refreshing of the corresponding Special I/O Unit (except those on Slave Racks).

C200HX/C200HG/C200HE-(Z)E PLCs

Data area	Bit(s)	Name	Function
SR Area	SR 25415	Special I/O Unit Error Flag	This flag is turned ON when there is an error in data transfers between the PLC and a Special I/O Unit or the same unit number has been set on more than one Special I/O Unit. The unit number of the affected Unit is written to AR 00 and SR 282.
	SR 27400 to SR 27415	Special I/O Unit Restarting Flags	These flags are turned ON while a Special I/O Unit is restarting. Each bit corresponds to the Unit with the same unit number.
	SR 28100 to SR 28115	Special I/O Unit Restart Bits	Turn the corresponding bit OFF→ON→OFF to restart a Special I/O Unit. Each bit corresponds to the Unit with the same unit number. (Bits AR 0100 to AR 0109 can also be used to restart Special I/O Units 0 to 9.)
	SR 28200 to SR 28215	Special I/O Unit Error Flags	These flags are turned ON when there is an error in data transfers between the PLC and the corresponding Special I/O Unit or the same unit number has been set on more than one Special I/O Unit. Each bit corresponds to the Unit with the same unit number. (Bits AR 0000 to AR 0009 show the same information for Special I/O Units 0 to 9.)

Data area	Bit(s)	Name	Function
AR Area	AR 0000 to AR 0009	Special I/O Unit Error Flags	These flags are turned ON when there is an error in data transfers between the PLC and the corresponding Special I/O Unit or the same unit number has been set on more than one Special I/O Unit. Each bit corresponds to the Unit with the same unit number. (Bits SR 28200 to SR 28209 show the same information for Special I/O Units 0 to 9.)
	AR 0100 to AR 0109	Special I/O Unit Restart Bits	Turn the corresponding bit OFF→ON→OFF to restart a Special I/O Unit. Each bit corresponds to the Unit with the same unit number. (Bits SR 28100 to SR 28109 can also be used to restart Special I/O Units 0 to 9.)
DM Area (PLC Setup)	DM 6620 (bits 00 to 09)	Special I/O Unit Refresh Disable Bits	Turn the corresponding bit ON to disable refreshing of the corresponding Special I/O Unit (except Remote I/O Racks). Each bit corresponds to the Unit with the same unit number. (Bits 00 to 09 of DM 6623 can also be used to disable refreshing of Special I/O Units 0 to 9.)
	DM 6623 (bits 00 to 15)	Special I/O Unit Refresh Disable Bits	Turn the corresponding bit ON to disable refreshing of the corresponding Special I/O Unit (except Remote I/O Racks). Each bit corresponds to the Unit with the same unit number. (Bits 00 to 09 of DM 6620 can also be used to disable refreshing of Special I/O Units 0 to 9.)

C200HS PLCs

Data area	Bit(s)	Name	Function
SR Area	SR 25415	Special I/O Unit Error Flag	This flag is turned ON when there is an error in data transfers between the PLC and a Special I/O Unit or the same unit number has been set on more than one Special I/O Unit. The unit number of the affected Unit is written to AR 00.
	SR 27400 to SR 27409	Special I/O Unit Restarting Flags	These flags are turned ON while a Special I/O Unit is restarting. Each bit corresponds to the Unit with the same unit number.
AR Area	AR 0000 to AR 0009	Special I/O Unit Error Flags	These flags are turned ON when there is an error in data transfers between the PLC and the corresponding Special I/O Unit or the same unit number has been set on more than one Special I/O Unit. Each bit corresponds to the Unit with the same unit number.
	AR 0100 to AR 0109	Special I/O Unit Restart Bits	Turn the corresponding bit OFF→ON→OFF to restart a Special I/O Unit. Each bit corresponds to the Unit with the same unit number.
DM Area (PLC Setup)	DM 6620 (bits 00 to 09)	Special I/O Unit Refresh Disable Bits	Turn the corresponding bit ON to disable refreshing of the corresponding Special I/O Unit (except Remote I/O Racks). Each bit corresponds to the Unit with the same unit number.

4-2 CS1W-SRM21 Master Unit for CS-series PLCs

4-2-1 Specifications and Part Names

Specifications

General Specifications

General specifications conform to those of the CS-series PLCs.

Performance Specifications

Item	Specifications	
Model	CS1W-SRM21	
Unit classification	Special I/O Unit	
Internal current consumption	5 V DC, 150 mA max.	
Weight	167 g max.	
Max. number of Masters	95 Units	96 Units
Master Unit mounting location	Can be mounted on the CPU Backplane or an Expansion I/O Backplane. Can't be mounted on a SYSMAC BUS Slave (RT) Rack.	
Max. number of I/O points per Master	256 points (128 inputs/128 outputs)	128 points (64 inputs/64 outputs)
Number of points per node number	8-point mode	
Number of usable node numbers per Master	IN0 to IN15 and OUT0 to OUT15 (up to 32 nodes can be connected)	IN0 to IN7 and OUT0 to OUT7 (up to 16 nodes can be connected)

Dimensions

The following diagram shows the dimensions of the CS1W-SRM21 Master Unit. All dimensions are in mm.

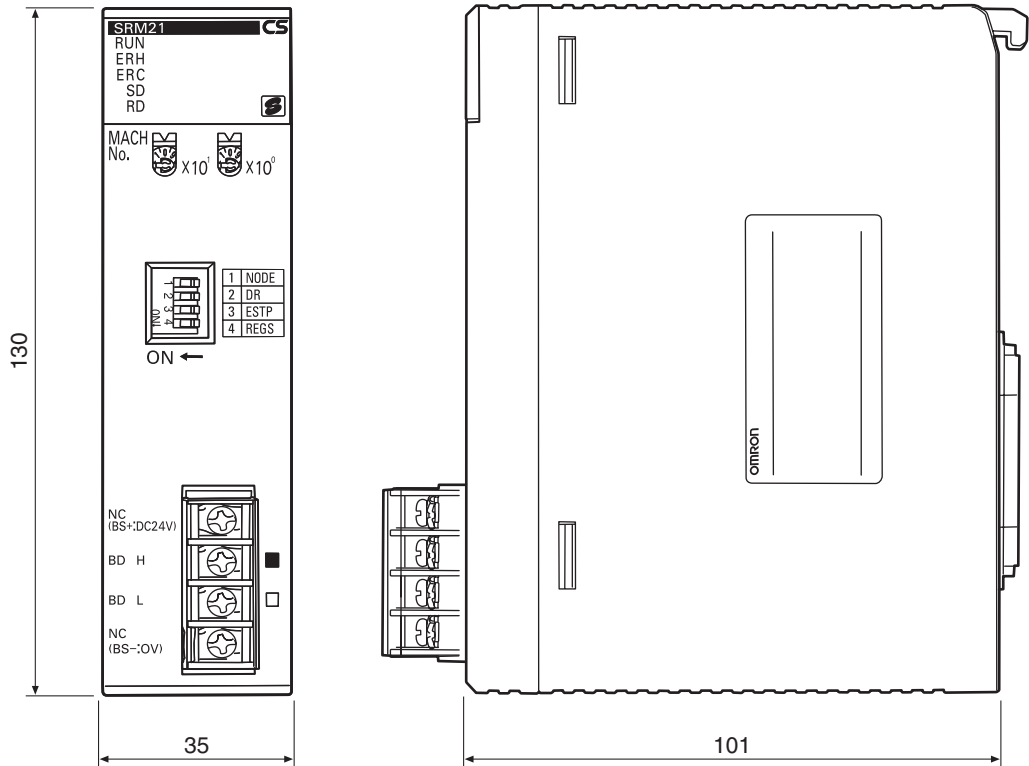

Refer to the *CS-series PLC Operation Manual* for installation dimensions of the CS1W-SRM21 when it is mounted on a Backplane.

Part Names and Functions

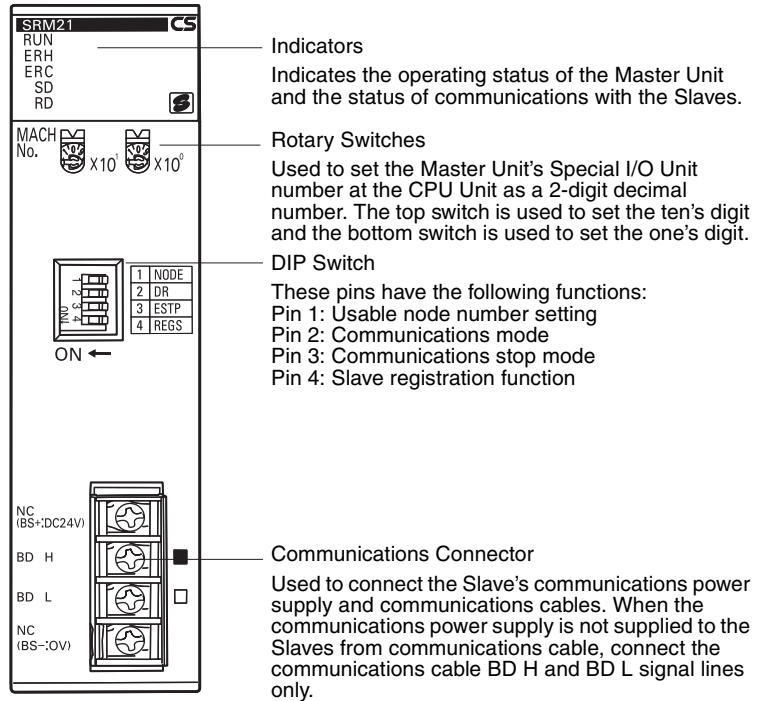

Indicators

The following table shows the meaning of the indicators.

Indicator	Status	Meaning
RUN (green)	ON	The Unit is operating normally.
	OFF	Indicates one of the following conditions (the ERH and ERC indicators light when errors other than the following errors occur): Power is not turned ON, watchdog timer error, etc.
ERH (red)	ON	Indicates one of the following conditions: Errors occurring at the CPU Unit, such as Special I/O Unit number setting error.
	OFF	The Unit is exchanging data with the CPU Unit normally.
ERC (red)	ON	Indicates one of the following conditions: Master Unit internal error, communications error, or verification error
	OFF	The Slaves are communicating normally.
SD (yellow)	ON	Data is being transmitted.
	OFF	Data is not being transmitted.
RD (yellow)	ON	Data is being received.
	OFF	Data is not being received.

4-2-2 Switch Settings

Rotary Switches

The rotary switches are used to set the Master Unit's Special I/O Unit number as a decimal number.



The range of usable node number settings (set using pin 1 of the DIP switch) are listed in the following table.

DIP switch pin 1 (NODE)	Usable node number setting	Unit number setting range
OFF	IN0 to IN7 and OUT0 to OUT7 (When using the words for one Special I/O Unit (10 words))	0 to 95
ON	IN0 to IN15 and OUT0 to OUT15 (When using the words for two Special I/O Units (20 words))	0 to 94

Any unit number in the ranges above can be set, as long as the same unit number has not been set on another Special I/O Unit mounted in the PLC. Set the unit number with a small standard screwdriver; be careful not to damage the switch.

Caution Always turn the PLC OFF before changing the unit number setting.

- The Master Unit is shipped with the unit number set to 00.
- The unit number setting determines which words in the PLC's Special I/O Unit Area and DM Area are allocated to the Master Unit. Refer to 4-2-3 I/O Allocations for details.
- When the usable node number setting is set to IN0 to IN15 and OUT0 to OUT15, the CompoBus/S Master Unit is allocated twice as many words in the PLC's Special I/O Unit Area (the words for unit number set on the Master and the next unit number). The Master's unit number and the next unit number cannot be used by another Special I/O Unit mounted to the PLC.
- If the same unit number is used for the Master and another Special I/O Unit, an I/O UNIT OVER error will occur in the PLC and it will not be possible to start up the CompoBus/S System.

DIP Switch

The DIP switch is used to set the range of usable node numbers of Slaves, the communications mode, communications stop mode, and Slave registration function.

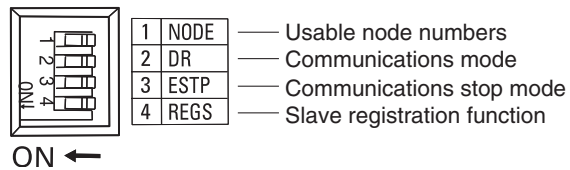

- Note**
1. Always turn the PLC OFF before changing the settings.
 2. DIP switch pins 1 to 4 are all set to OFF at the factory.

Set pin 1 (NODE) of the DIP switch as shown in the following table.

Pin 1 setting	Usable node number setting	Maximum I/O points	Words allocated in the Special I/O Unit Area
OFF	IN0 to IN7 and OUT0 to OUT7 (up to 16 nodes can be connected)	128 points (64 inputs, 64 outputs)	10 words (words for one unit) Input/output data: 4 input words and 4 output words Status information: 2 words
ON	IN0 to IN15 and OUT0 to OUT15 (up to 32 nodes can be connected)	256 points (128 inputs, 128 outputs)	20 words (words for two units) Input/output data: 8 input words and 8 output words Status information: 4 words

- Note**
1. The usable node number setting determines the total number of words allocated, and combined with the DIP switch pin 2 setting, determines the Slaves' communication cycle. Refer to 4-2-3 I/O Allocations for details.
 2. When the usable node number setting is set to IN0 to IN15 and OUT0 to OUT15, the CompoBus/S Master Unit is allocated twice as many words in the PLC's Special I/O Unit Area (the words for unit number set on the Master and the next unit number). The Master's unit number and the next unit number cannot be used by another Special I/O Unit mounted to the PLC.

Set pin 2 (DR) of the DIP switch as shown in the following table.

Pin 2 setting	Communications mode setting	Communications distance	Communications baud rate	Communications cycle time
OFF	High-speed Communications Mode	100 m max.	750 kbps	0.5 ms (pin 1 OFF) or 0.8 ms (pin 1 ON)
ON	Long-distance Communications Mode	500 m max.	93.75 kbps	4.0 ms (pin 1 OFF) or 6.0 ms (pin 1 ON)

- Note**
1. The communications mode of the Master Unit must match that of all Slaves. If the CompoBus/S System contains a Slave whose communications mode does not agree with that of the Master Unit, the COMM indicator on that Slave will not light, and normal communications with that Slave will not be possible. Other Slaves will not be adversely affected. (In such cases, the COMM indicator on the Master Unit will light normally.) For information on the Master Unit indicator statuses, refer to 6-3 Checking Operations of CS-series and CJ-series Master Units.
 2. The setting of pin 2 determines the communications distance, baud rate, and cycle time as shown in the above table.

Set pin 3 of the DIP switch as shown in the following table.

Pin 3 setting	Communications stop mode setting
OFF	Communications mode Continues remote I/O communications when a communications error occurs.
ON	Communications stop mode Stops remote I/O communications when a communications error occurs.

If communications stop mode is set, communications automatically stop when a remote I/O communications error occurs, thereby preventing system malfunctions.

Note If the communications stop mode causes remote I/O communications to stop, communications will not restart when the cause of the error is removed. Turn ON the power again or restart the Unit to resume communications. Refer to 4-2-4 Slave Registration Function and Communications Stop Mode.

Set pin 4 (REGS) of the DIP switch as shown in the following table.

Pin 4 setting	Slave registration function setting
OFF	Slave registration function setting disabled
ON	Slave registration function setting enabled

The Slave registration function monitors Slaves that are joined in the network, and those unregistered Slaves that are illegally joined to the network, based on Slave information registered in the Slave registration tables (Special I/O Unit DM Area). Refer to 4-2-4 Slave Registration Function and Communications Stop Mode.

Note Set the Slave registration tables in the Special I/O Unit DM Area when using the Slave registration function. Refer to 4-2-4 Slave Registration Function and Communications Stop Mode.

4-2-3 I/O Allocations

CS-series Master Units are allocated words for Slave I/O data and status flags in the Special I/O Unit Area of the Master. Words in the Special I/O Unit DM Area is allocated for the Slave registration function and communications stop mode.

Allocations and Master Unit Settings

The areas used by the Master Unit depend on the Master Unit settings, as shown in the following table.

Setting at Master Unit	Status	Affect on allocation
Usable node number settings (DIP switch pin 1)	OFF	Uses 10 words (words for one unit) from the Special I/O Unit Area as follows: Output: 4 words, input: 4 words, status: 2 words. (100 words are allocated in the Special I/O Unit DM Area)
	ON	Uses 20 words (words for two units) from the Special I/O Unit Area as follows: Output: 8 words, input: 8 words, status: 4 words. (100 words are allocated in the Special I/O Unit DM Area)
Special I/O Unit number setting (rotary switch)	n	First word of the area used in the Special I/O Unit Area is CIO 2000 + (n×10) words First word of the area used in the Special I/O Unit DM Area is D20000 + (n×100) words

Slave Allocations

Slaves are allocated in the Special I/O Unit Area as shown in the following diagram. In CompoBus/S Systems, node numbers of Input Slaves and Output Slaves are treated separately so the same number can be allocated.

I/O Allocations when Pin 1 Is OFF

When pin 1 is OFF and node addresses IN0 to IN7 and OUT0 to OUT7 (64 inputs/64 outputs max) are used, words are allocated to the Slaves for each node number as shown in the following diagram.

Special I/O Unit Area in Master PLC

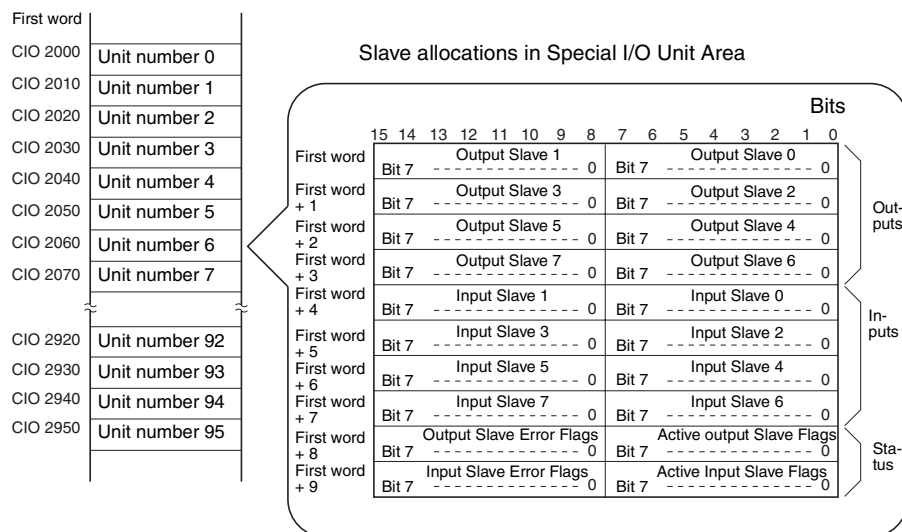

I/O Allocations when Pin 1 is ON

When pin 1 is ON and node addresses IN0 to IN15 and OUT0 to OUT15 (up to 128 inputs/128 outputs) are used, words are allocated to the Slaves for each node number as shown in the following diagram.

Special I/O Unit Area in Master PLC

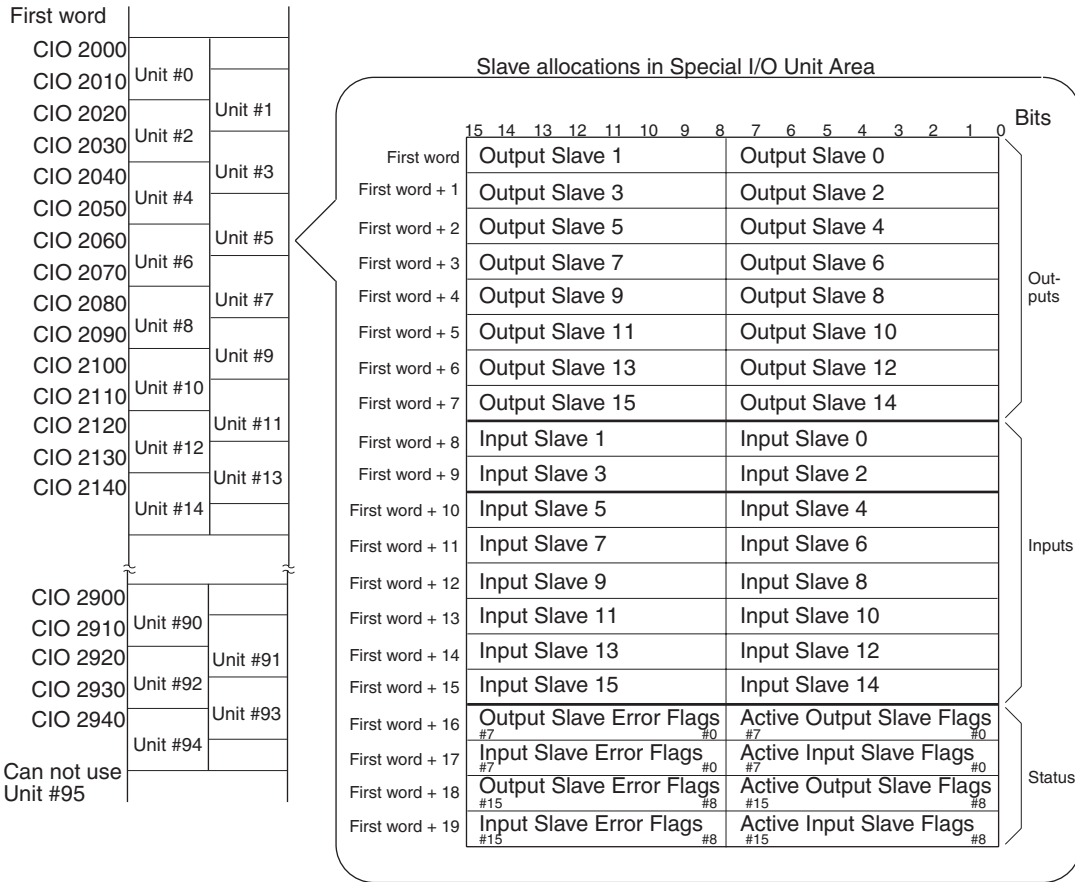

Slave I/O and Corresponding Areas

Slave with 8 Inputs or 8 Outputs

The Slave is treated as one node number for output or input.

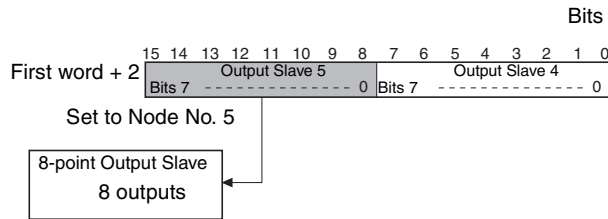

Slave with 16 Inputs or 16 Outputs

The Slave is treated as two node numbers for output or input, and allocated in the same words as follows:

- When an odd node number has been set:
Uses node number setting – 1 and node number setting
- When an even node number has been set:
Uses node number setting and node number setting + 1.

Example: When a 16-point Output Slave set as node number 5, the areas for Output Slaves 4 and 5 are used. Other Output Slaves cannot use the area allocated for Output Slave 4.

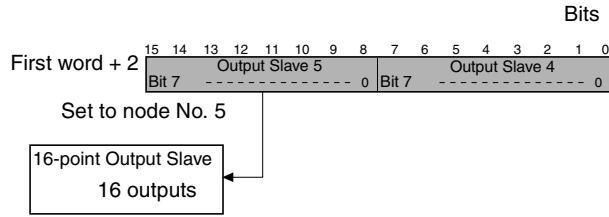

Slave with Mixed I/O (8 Inputs and 8 Outputs)

Slaves that have both outputs and inputs are also assigned a single node number, so the same node number is used for both outputs and inputs.

Example: When a Slave with 8 inputs and 8 outputs set as node number 2, the area for node number 2 outputs and inputs is used.

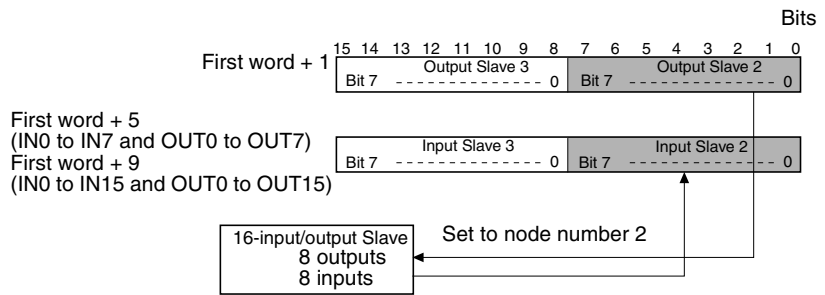

Slave with 4 Outputs or 4 Inputs

The Slave is treated as one node number for output or input. The Slave uses the rightmost 4 bits only, however, of the area allocated for one node number. (The leftmost 4 bits cannot be used by another Slave.)

- When an odd node number has been set:
Bits 8 to 11 are used and bits 12 to 15 are not used.
- When an even node number has been set:
Bits 0 to 3 are used and bits 4 to 7 are not used.

Example: When a Slave with 4 inputs is set as node number 7, the Slave is allocated the rightmost 4 bits (bits 8 to 11) in the area assigned for input node number 7.

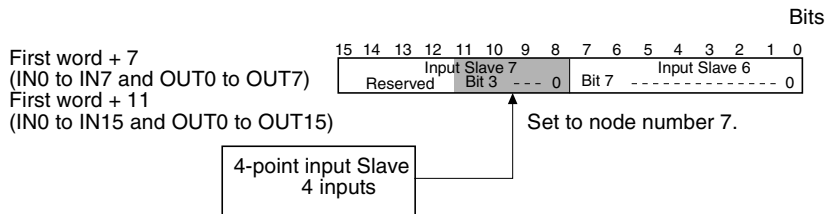

Slave with Mixed I/O (4 Outputs and 4 Inputs)

Slaves that have both outputs and inputs are also assigned a single node number, so the same node number is used for both outputs and inputs. The Slave uses the rightmost 4 bits only, however, of the area allocated for one node number. (The leftmost 4 bits cannot be used by another Slave.)

- When an odd node number has been set:
Bits 8 to 11 are used and bits 12 to 15 are not used.

- When an even node number has been set:
Bits 0 to 3 are used and bits 4 to 7 are not used.

Example: When a Slave with 4 outputs and 4 inputs is set to node number 2, the rightmost 4 bits (bits 0 to 3) of the area for node number 2 for both output and input are used.

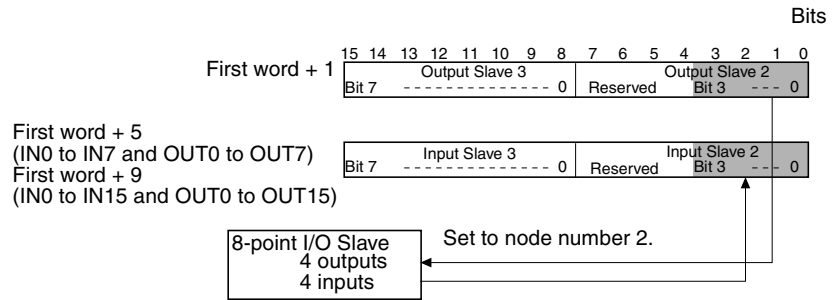

Slave with 32 Outputs or 32 Inputs

The Slave is treated as four node numbers for output or input and is allocated 2 consecutive words, as follows:

- When an odd node number has been set:
Uses (node number setting – 1) to (node number setting + 2)
- When an even node number has been set:
Uses (node number setting) to (node number setting + 3).

Example: When a Slave with 32 outputs is set to node number 1, it uses the area assigned for Output Slave 0 to Output Slave 3. The area for Output Slave 0, 2, and 3 cannot be used for another Output Slave.

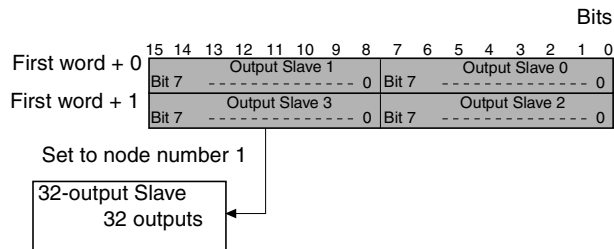

Slave with Mixed I/O (16 Outputs and 16 Inputs)

Slaves that have both outputs and inputs are also assigned a single node number, so the same node number is used for both outputs and inputs, and each is regarded as two node numbers. Outputs and inputs are allocated to the same words, as follows:

- When an odd node number has been set:
Uses (node number setting – 1) and (node number setting)
- When an even node number has been set:
Uses (node number setting) and (node number setting + 1).
- Example: When a Slave with 16 inputs and 16 outputs is set to node number 3, it uses Output Slave 2 and 3, and Input Slave 2 and 3. Output Slave 2 and Input Slave 2 cannot be used by other Slaves.

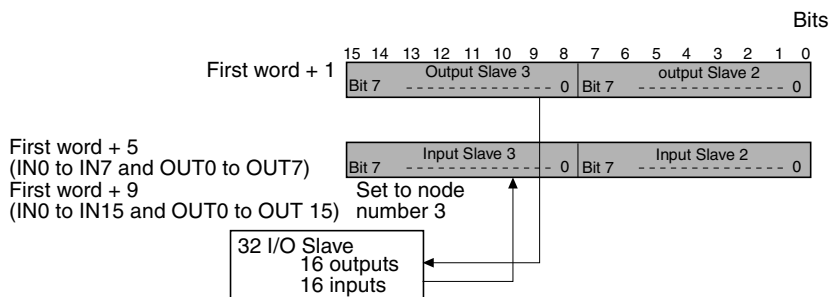

Using an Analog Terminal

An Analog Terminal uses 16, 32, 48, or 64 points. I/O allocations are shown in the following table.

Number of points allocated	Node number setting	Node numbers used
64 points SRT2-AD04: 4 inputs	Odd number	Node number setting – 1 to node number setting + 6
	Even number	Node number setting to node number setting + 7
48 points SRT2-AD04: 3 inputs	Odd number	Node number setting – 1 to node number setting + 4
	Even number	Node number setting to node number setting + 5
32 points SRT2-AD04: 2 inputs SRT2-DA02: 2 outputs	Odd number	Node number setting – 1 to node number setting + 2
	Even number	Node number setting to node number setting + 3
16 points SRT2-AD04: 1 input SRT2-DA02: 1 output	Odd number	Node number setting – 1 to node number setting
	Even number	Node number setting to node number setting + 1

Do not use words for the node number outside the words allocated in the Master Unit. If words outside the specified output or input areas are used, the Unit cannot participate in communications and the COMM indicator will not turn ON.

Status Flag Functions

The functions of the flags in the status area are described below.

- Active Output Slave Flags

These flags indicate which Output Slaves (0 to 15) are active nodes in the system. When the corresponding flag is ON, the Slave is an active node. All of these flags are reset when the power is turned ON or operation is restarted.

 - 0 (OFF): No communications participation
The node hasn't participated in communications even once.
 - 1 (ON): Communications participation
The flag won't change even if the node is withdrawn from the system.
- Active Input Slave Flags

These flags indicate which Input Slaves (0 to 15) are active nodes in the system. When the corresponding flag is ON, the Slave is an active node. All of these flags are reset when the power is turned ON or operation is restarted.

 - 0 (OFF): No communications participation
The node hasn't participated in communications even once.

1 (ON): Communications participation

The flag won't change even if the node is withdrawn from the system.

- Output Slave Error Flags

These flags indicate the communications status of the Output Slaves (0 to 15). All of these flags are reset when the power is turned ON or operation is restarted.

0 (OFF): Communications normal or inactive node

1 (ON): Withdrawn from communications (communications error)

- Input Slave Error Flags

These flags indicate the communications status of the Input Slaves (0 to 15). All of these flags are reset when the power is turned ON or operation is restarted.

0 (OFF): Communications normal or inactive node

1 (ON): Withdrawn from communications (communications error)

- Note**
1. When the CompoBus/S System starts up, inputs from Input Slaves and outputs to Output Slaves become effective when the Active Slave Flag for the Slave is turned ON. It is recommended to write a ladder program that verifies that the Slave's Active Slave Flag is ON and its Error Flag is OFF before transmitting or receiving I/O data.
 2. When CS-series Master Units are set to communications stop mode, communications will stop when the Output Slave Error Flag or Input Slave Error Flag will turn ON. (Refer to 4-2-4 *Slave Registration Function and Communications Stop Mode*.)

4-2-4 Slave Registration Function and Communications Stop Mode

The CS-series Master Units now support a Slave registration function and communications stop mode. This new capability enables the CompoBus/S System to deliver increased reliability.

Slave Registration Function

The words allocated in the DM Area to the Master Unit as a Special I/O Unit contains a Slave registration table. By registering the Slaves that are normally participating in communications, the Slaves that are not joined to the network or are slow to join, or unregistered Slaves that are illegally joined can be monitored.

This function prevents system malfunctions due to incorrect wiring on site. The Slave registration function is enabled by turning ON pin 4 of the DIP switch on the Master Unit.

Communications Stop Mode

By setting communications stop mode, remote I/O communications will stop when a communications error occurs, and information on the Slave with the communications error is stored in the Special I/O Unit DM Area.

This function prevents the System from running on incorrect I/O data without having to disconnect a Slave with a communications error, and enables quick troubleshooting of the communications error.

When remote I/O communications are stopped in communications stop mode, they will not resume when the cause of the error is removed. To restart remote I/O communications, turn ON the power again, or restart the Unit. When the Unit is set to standard communications mode, even if a communications error occurs, the remote I/O communications will continue with the Slave with the error disconnected. Also, the Slave with the communications error is not

recorded in the Special I/O Unit DM Area, so a standard status area check using the program is required.

If a verification error occurs while using the Slave registration function, as it is not a communications error, remote I/O communications will continue even if communications stop mode is enabled.

Communications stop mode is set using pin 3 of the DIP switch on the Master Unit. (pin 3 ON: communications stop mode, pin 3 OFF: normal communications mode)

Words Allocated for Slave Registration and Communications Stop Mode

The words used for the Slave registration function and communications stop mode are allocated in the Special I/O Unit DM Area according to the Master Unit's Special I/O Unit number, as shown below.

First word = D20000 + (unit number × 100)

	15	14	13	12	11	10	9	8	7	6	5	4	3	2	1	0	Bit
First word	Output Slave Registration Table (Used only when Slave registration function is enabled.)																CPU Unit-to-Master Unit (The contents of this area is transferred to the Master Unit from the CPU Unit when the power is turned ON. When the contents has changed, turn ON the power again.)
First word + 1	Input Slave Registration Table (Used only when Slave registration function is enabled.)																
First word + 2	Registered Slave Participation Monitoring Time (Used only when Slave registration function is enabled.)																
First word + 3	Reserved for system use (Cannot be used.)																
First word + 4	Status Flags (Used when Slave registration or communications stop mode are enabled.)																Master Unit-to-CPU Unit
First word + 5	Communications Stopped Node Number and Slave Type (Used only when communications stop mode is enabled.)																
First word + 6	Output Slave Verification Error: Slave Missing (Used only when Slave registration function is enabled.)																
First word + 7	Input Slave Verification Error: Slave Missing (Used only when Slave registration function is enabled.)																
First word + 8	Output Slave Verification Error: Unregistered Slave in Network (Used only when Slave registration function is enabled.)																
First word + 9	Input Slave Verification Error: Unregistered Slave in Network (Used only when Slave registration function is enabled.)																
First word + 10 to First word + 99	Not used. (Can be used as work bits/words.)																

The contents from the first word to the first word +9 cannot be used for any other purpose. They can be used, however, if the Slave registration function and communications stop mode are not enabled.

The functions of each area are given in the following table.

Word	Bit	Name	Function		
+0	00	Output Slave Registration Table	OUT0	Registers a list of the Output Slaves that are normally operating in the network. This list is used for checking the Slaves with the Slave registration function. Bits 00 to 15 correspond to Slave node numbers 0 to 15. The Output Slave is registered by turning ON its corresponding bit.	The bits in the Special I/O Unit Area must be registered to correspond to the node numbers actually used by the Slaves. Therefore, for Slaves with 16 points or higher, turn ON the bits for the other node numbers too. For example, the two consecutive bits used by a 16-point Slave or the four consecutive bits used by a 32-point Slave must be set.
	01		OUT1		
	02		OUT2		
	to		to		
	13		OUT13		
	14		OUT14		
	15		OUT15		
+1	00	Input Slave Registration table	IN0	Registers a list of the Input Slaves that are normally operating in the network. This list is used to check the Slaves with the Slave registration function. Bits 00 to 15 correspond to Slave node numbers 0 to 15. The Input Slave is registered by turning ON its corresponding bit.	
	01		IN1		
	02		IN2		
	to		to		
	13		IN13		
	14		IN14		
	15		IN15		
+2	00 to 15	Registered Slave Participation Monitoring Time	The waiting time between when the Master Unit is started until the Slaves start to be checked using the Slave registration function. The time is set in increments of 1 ms as a hexadecimal. The setting range is 0000 (default is 2000 ms) or 0001 to FFDC (1 to 65500 ms). If the monitoring time lapses and there are still registered Slaves not joined in the network, a verification error (Slave missing) will occur.		
+3	00 to 15	Reserved for system use.			

Word	Bit	Name	Function
+4	00	Registration Completed Flag	This flag is turned ON when all registered Slaves have joined the network. If all the registered Slaves have joined the network within the registered Slave participation monitoring time this flag will turn ON even if unregistered Slaves have also joined. The flag will not turn ON, however, if there are no Slaves set in the Slave registration table. The flag will remain ON until the power is turned OFF and ON again or the Unit is restarted.
	00 to 07	Reserved for system use.	
	08	Verification Error Flag: Slave Missing	This flag is turned ON under the following conditions. Registered Slaves do not join the network within the registered Slave participation monitoring time. When the Slave that caused the verification error is joined in the network, the flag will automatically be turned OFF. Check which Slave caused the error in the bit for verification error (Slave missing) in Output Slave (first word + 6) or verification error (Slave missing) in Input Slave (first word + 7).
	09	Verification Error Flag: Unregistered Slave in Network	This flag is turned ON when an unregistered Slave has joined the network. The flag will remain ON until the power is turned OFF and ON again or the Unit is restarted, even if the Slave that caused the verification error is removed from the network. Check which Slave caused the error in the bit for Output Slave verification error (unregistered Slave in network) (first word + 8) or Input Slave verification error (unregistered Slave in network) (first word + 9).
	10	Communications Stopped Flag	This flag is turned ON when the Master Unit is set to communications stop mode and remote I/O communications stop due to a communications error. Once the flag has turned ON, the status remains until the power is turned OFF and ON again or the Unit is restarted. Check which Slave caused the error in the bits for communications stopped node number (bits 00 to 07 of first word + 5) and communications stopped Slave type (bit 15 of first word + 5).
	11 to 14	Reserved for system use.	
	15	Error Flag	This flag is turned ON when any of the bits 08 to 10 are set to 1 (ON). The flag is automatically turned OFF when all the bits 08 to 10 are turned OFF.
+5	00 to 07	Communications Stopped Node Number	When the Master Unit is set to communications stop mode and remote I/O communications stop due to a communications error, the node number of the Slave that caused the error is stored as a 2-digit hexadecimal (00 to 0F: 1 to 15). Check the Slave type (Output or Input) in the word for communications stopped Slave type (bit 15 of first word + 5). The node address stored will be held until the power is turned OFF and ON again or the Unit is restarted.
	08 to 14	Reserved for system use.	
	15	Communications Stopped Slave type	When the Master Unit is set to communications stop mode and remote I/O communications stop due to a communications error, the Slave type of the Slave that caused the error is stored as follows: 0 (OFF): Output Slave 1 (ON): Input Slave Check which Slave caused the error in the bits for communications stopped node number (bits 00 to 07 of first word + 5) When communications have stopped, the bit status is held until the power is turned OFF and ON again or the Unit is restarted.

Word	Bit	Name	Function		
+6	00	Output Slave Verification Error: Slave Missing	OUT0	When the Slave registration function is enabled, the bit corresponding to the node number of the Output Slave that caused the verification error (Slave missing) will be turned ON. Bits 00 to 15 correspond to Output Slave node numbers 1 to 15. When the Slave that caused the verification error joins the network, the bit will automatically turned OFF.	The bits in the Special I/O Unit Area correspond to the node numbers actually used by the Slaves. Therefore, for Slaves with 16 points or higher, the bits other than those set for the node number may also be turned ON. For example, the two consecutive bits used by a 16-point Slave or the four consecutive bits used by a 32-point Slave may be turned ON at the same time.
	01		OUT1		
	02		OUT2		
	to		to		
	13		OUT13		
	14		OUT14		
	15		OUT15		
+7	00	Input Slave Verification Error: Slave Missing	IN0	When the Slave registration function is enabled, the bit corresponding to the node number of the Input Slave that caused the verification error (Slave missing) will be turned ON. Bits 00 to 15 correspond to Input Slave node numbers 1 to 15. When the Slave that caused the verification error joins the network, the bit will automatically turned OFF.	
	01		IN1		
	02		IN2		
	to		to		
	13		IN13		
	14		IN14		
	15		IN15		
+8	00	Output Slave Verification Error: Unregistered Slave in Network	OUT0	When the Slave registration function is enabled, the bit corresponding to the node number of the Output Slave where a verification error (unregistered Slave in network) will be turned ON. Bits 00 to 15 correspond to Output Slave node numbers 1 to 15. Once a bit has been turned ON the status will be held until the power is turned OFF and ON again or the Unit is restarted.	
	01		OUT1		
	02		OUT2		
	to		to		
	13		OUT13		
	14		OUT14		
	15		OUT15		
+9	00	Input Slave Verification Error: Unregistered Slave in Network	IN0	When the Slave registration function is enabled, the bit corresponding to the node number of the Input Slave where a verification error (unregistered Slave in network) will be turned ON. Bits 00 to 15 correspond to Input Slave node numbers 1 to 15. Once a bit has been turned ON the status will be held until the power is turned OFF and ON again or the Unit is restarted.	
	01		IN1		
	02		IN2		
	to		to		
	13		IN13		
	14		IN14		
	15		IN15		

Slave Registration Function Procedure

When the Slave registration function is used, the Output/Input Slave registration table and registered Slave participation monitoring time must be set in the Special I/O Unit DM Area, but the power must be turned OFF and ON again or the Unit restarted to enable the settings.

The following example shows the procedure for using the Slave registration function. (Information on other Slave registration function settings and connections are omitted here.)

- 1,2,3...**
1. Turn OFF pin 4 of the DIP switch on the Master Unit to disable the Slave registration function.
 2. Turn ON the power to the CPU Unit to which the Master Unit is mounted.
 3. Use a Programming Device for the CPU Unit to set the following information in the Special I/O Unit DM Area words used by the Master Unit.
 - Output Slave registration table
 - Input Slave registration table
 - Registration Slave participation monitoring time
 4. Turn OFF the power to the CPU Unit to which the Master Unit is mounted.
 5. Turn ON pin 4 of the DIP switch on the Master Unit to enable the Slave registration function
 6. Turn ON the power to the CPU Unit to which the Master Unit is mounted or restart the Master Unit.

The settings in the Special I/O Unit DM Area can be set while pin 4 of the DIP switch on the Master Unit is set to ON, but a verification error may occur due to the incorrectly set Slave registration table.

4-2-5 Allocations for Master Unit in PLC

The following table shows the words in the CPU Unit that are related to the Master Unit.

Data area	Bit(s)	Name	Function
Auxiliary Area (A)	A33000 to A33515	Special I/O Unit Restarting Flags	These flags are turned ON while a Special I/O Unit is restarting. Each bit corresponds to the Unit with the same unit number.
	A40113	Dual Number Use Error Flag (Fatal Error)	This flag is turned ON in the following situations: When the same unit number has been set on more than one CS1 CPU Bus Unit. When the same unit number has been set on more than one Special I/O Unit. When the same word is allocated more than once for Basic I/O Units.
	A40206	Special I/O Unit Error Flag	This flag is turned ON when the same unit number has been set on more than one Special I/O Unit, or when an error has occurred during data transfer between the PLC and the Special I/O Unit. The unit number of the Unit is written to word A418.
	A41100 to A41615	Special I/O Unit Number Duplication Flags	These flags are turned ON when the same unit number has been set on more than one Special I/O Unit (i.e., when A40113 is ON). Each bit corresponds to the Unit with the same unit number.
	A41800 to A42315	Special I/O Unit Error Flags	These flags are turned ON when the same unit number has been set on more than one Special I/O Unit, or when an error has occurred during data transfer between the PLC and the Special I/O Unit. Each bit corresponds to the Unit with the same unit number.
	A50200 to A50715	Special I/O Unit Restart Bits	Turn the corresponding bit ON and then OFF to restart a Special I/O Unit. Each bit corresponds to the Unit with the same unit number.
PLC Setup	22600 to 23115	Special I/O Unit Refresh Disable Bits	Turn the corresponding bit ON to disable refreshing of the corresponding Special I/O Unit (except those on Slave Racks).

4-3 CJ1W-SRM21 Master Unit for CJ-series PLCs

4-3-1 Specifications and Part Names

Specifications

General Specifications

General specifications conform to those of the CJ-series PLCs.

Performance Specifications

Item	Specifications	
Model	CJ1W-SRM21	
Unit classification	Special I/O Unit	
Internal current consumption	5 V DC, 150 mA max.	
Allowable current from the Slave communications power supply connection terminals	4 A (14 to 26.4 V DC)	
Weight	66 g max. (including provided connector)	
Max. number of Masters	40 Units	
Master Unit mounting location	Can be connected in the CJ-series CPU Rack or Expansion I/O Rack.	
Max. number of I/O points per Master	256 points (128 inputs/128 outputs)	128 points (64 inputs/64 outputs)
Number of points per node number	8-point mode	
Number of usable node numbers per Master	IN0 to IN15 and OUT0 to OUT15 (up to 32 nodes can be connected)	IN0 to IN7 and OUT0 to OUT7 (up to 16 nodes can be connected)

Dimensions

The following diagram shows the dimensions of the CJ1W-SRM21-V1 Master Unit. All dimensions are in mm.

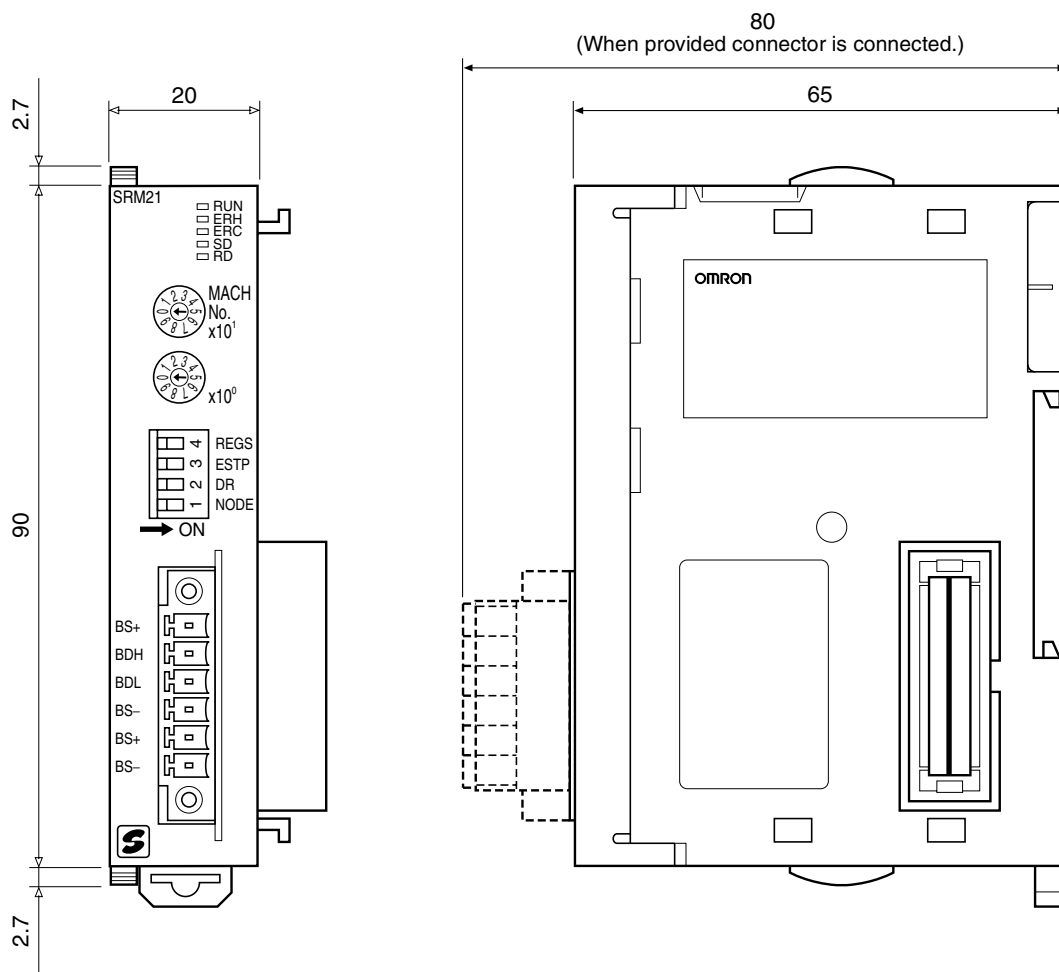

Refer to the *CJ-series Operation Manual* for details on installing the CJ1W-SRM21 when it is connected in a CJ-series CPU Rack or Expansion Rack.

Part Names and Functions

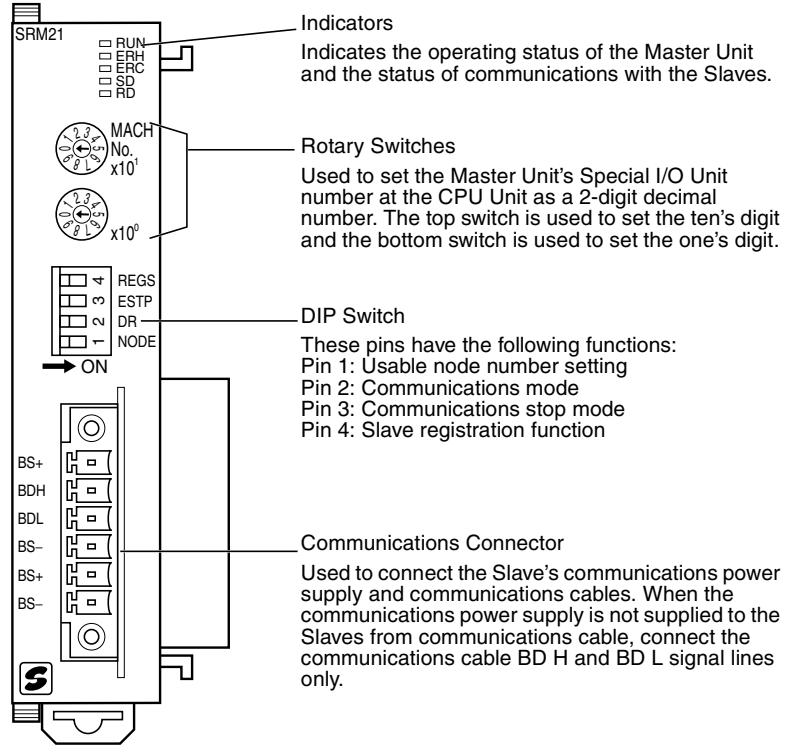

Indicators

The following table shows the meaning of the indicators.

Indicator	Status	Meaning
RUN (green)	ON	The Unit is operating normally.
	OFF	Indicates one of the following conditions (the ERH and ERC indicators light when errors other than the following errors occur): Power is not turned ON, watchdog timer error, etc.
ERH (red)	ON	Indicates one of the following conditions: Errors occurring at the CPU Unit, such as Special I/O Unit number setting error.
	OFF	The Unit is exchanging data with the CPU Unit normally.
ERC (red)	ON	Indicates one of the following conditions: Master Unit internal error, communications error, or verification error
	OFF	The Slaves are communicating normally.
SD (yellow)	ON	Data is being transmitted.
	OFF	Data is not being transmitted.
RD (yellow)	ON	Data is being received.
	OFF	Data is not being received.

4-3-2 Switch Settings

Rotary Switches

The rotary switches are used to set the Master Unit's Special I/O Unit number as a decimal number.

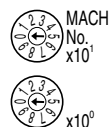

The range of usable node number settings (set using pin 1 of the DIP switch) are listed in the following table.

DIP switch pin 1 (NODE)	Usable node number setting	Unit number setting range
OFF	IN0 to IN7 and OUT0 to OUT7 (When using the words for one Special I/O Unit (10 words))	0 to 95
ON	IN0 to IN15 and OUT0 to OUT15 (When using the words for two Special I/O Units (20 words))	0 to 94

Any unit number in the ranges above can be set, as long as the same unit number has not been set on another Special I/O Unit mounted in the PLC. Set the unit number with a small standard screwdriver; be careful not to damage the switch.

Caution Always turn the PLC OFF before changing the unit number setting.

- The Master Unit is shipped with the unit number set to 00.
- The unit number setting determines which words in the PLC's Special I/O Unit Area and DM Area are allocated to the Master Unit. Refer to 4-1-3 *I/O Allocations in CS-series, C200HX/C200HG/C200HE-(Z)E, and C200HS PLCs* for details.
- When the usable node number setting is set to IN0 to IN15 and OUT0 to OUT15, the CompoBus/S Master Unit is allocated twice as many words in the PLC's Special I/O Unit Area (the words for unit number set on the Master and the next unit number). The Master's unit number and the next unit number cannot be used by another Special I/O Unit mounted to the PLC.
- If the same unit number is used for the Master and another Special I/O Unit, an I/O UNIT OVER error will occur in the PLC and it will not be possible to start up the CompoBus/S System.

DIP Switch

The DIP switch is used to set the range of usable node numbers of Slaves, the communications mode, communications stop mode, and Slave registration function.

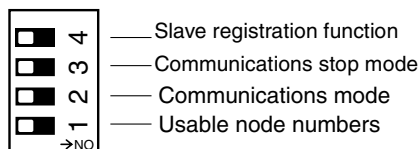

- Note**
1. Always turn the PLC OFF before changing the settings.
 2. DIP switch pins 1 to 4 are all set to OFF at the factory.

Set pin 1 (NODE) of the DIP switch as shown in the following table.

Pin 1 setting	Usable node number setting	Maximum I/O points	Words allocated in the Special I/O Unit Area
OFF	IN0 to IN7 and OUT0 to OUT7 (up to 16 nodes can be connected)	128 points (64 inputs, 64 outputs)	10 words (words for one unit) Input/output data: 4 input words and 4 output words Status information: 2 words
ON	IN0 to IN15 and OUT0 to OUT15 (up to 32 nodes can be connected)	256 points (128 inputs, 128 outputs)	20 words (words for two units) Input/output data: 8 input words and 8 output words Status information: 4 words

- Note**
1. The usable node number setting determines the total number of words allocated, and combined with the DIP switch pin 2 setting, determines the Slaves' communication cycle. Refer to 4-1-3 *I/O Allocations in CS-series, C200HX/C200HG/C200HE-(Z)E, and C200HS PLCs* for details.
 2. When the usable node number setting is set to IN0 to IN15 and OUT0 to OUT15, the CompoBus/S Master Unit is allocated twice as many words in the PLC's Special I/O Unit Area (the words for unit number set on the Master and the next unit number). The Master's unit number and the next unit number cannot be used by another Special I/O Unit mounted to the PLC.

Set pin 2 (DR) of the DIP switch as shown in the following table.

Pin 2 setting	Communications mode setting	Communications distance	Communications baud rate	Communications cycle time
OFF	High-speed Communications Mode	100 m max.	750 kbps	0.5 ms (pin 1 OFF) or 0.8 ms (pin 1 ON)
ON	Long-distance Communications Mode	500 m max.	93.75 kbps	4.0 ms (pin 1 OFF) or 6.0 ms (pin 1 ON)

- Note**
1. The communications mode of the Master Unit must match that of all Slaves. If the CompoBus/S System contains a Slave whose communications mode does not agree with that of the Master Unit, the COMM indicator on that Slave will not light, and normal communications with that Slave will not be possible. Other Slaves will not be adversely affected. (In such cases, the COMM indicator on the Master Unit will light normally.) For information on the Master Unit indicator statuses, refer to 6-3 *Checking Operations of CS-series and CJ-series Master Units*.
 2. The setting of pin 2 determines the communications distance, baud rate, and cycle time as shown in the above table.

Set pin 3 of the DIP switch as shown in the following table.

Pin 3 setting	Communications stop mode setting
OFF	Communications mode Continues remote I/O communications when a communications error occurs.
ON	Communications stop mode Stops remote I/O communications when a communications error occurs.

If communications stop mode is set, communications automatically stop when a remote I/O communications error occurs, thereby preventing system malfunctions.

Note If the communications stop mode causes remote I/O communications to stop, communications will not restart when the cause of the error is removed. Turn ON the power again or restart the Unit to resume communications. Refer to 4-3-5 Slave Registration Function and Communications Stop Mode.

Set pin 4 (REGS) of the DIP switch as shown in the following table.

Pin 4 setting	Slave registration function setting
OFF	Slave registration function setting disabled
ON	Slave registration function setting enabled

The Slave registration function monitors Slaves that are joined in the network, and those unregistered Slaves that are illegally joined to the network, based on Slave information registered in the Slave registration tables (Special I/O Unit DM Area). Refer to 4-3-5 Slave Registration Function and Communications Stop Mode.

Note Set the Slave registration tables in the Special I/O Unit DM Area when using the Slave registration function. Refer to 4-3-5 Slave Registration Function and Communications Stop Mode.

4-3-3 Wiring and Installing Communications Cables

Communications Connector Wiring

Applicable Connectors

Use either of the following connectors when connecting CompoBus/S communications cable to a CJ-series Master Unit

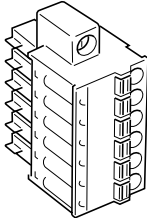
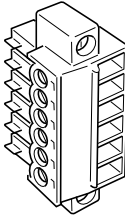
Manufacturer/Model	Appearance	Remarks
Phoenix Contact FK-MCP1.5/6-STF-3.81		Screwless terminals (provided with the CJ-series Master Unit)
Phoenix Contact MC1.5/6-STF-3.81		Screw terminals

Communications Connector Pin Arrangement

Screwless Terminals
FK-MCP1.5/6-STF-3.81

Screw Terminals
MC1.5/6-STF-3.81

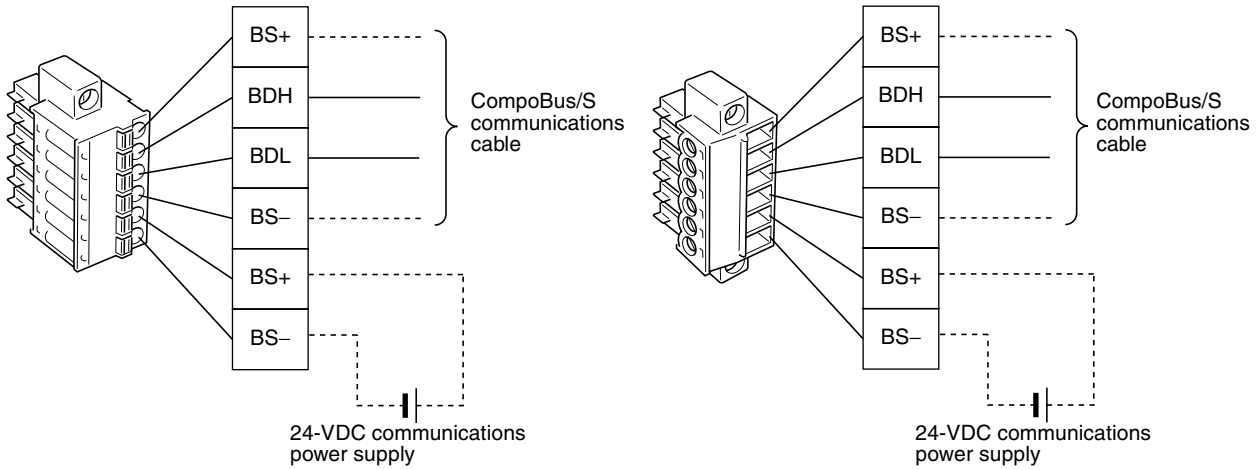

The BS+ and BS- terminals are internally connected. The BS+ and BS- terminals are used to supply communications power supply to the Slaves (they are not used for the Master Unit). When supplying communications power at the Slave, such as by using 2-conductor VCTF cable, connect the BD H and BD L terminals.

Note The signal wires for Special Flat Cable are shown in the following diagram. Special Flat Cable can be easily connected to CJ-series Master Units because the upper four pins of the communications connector have the same pin arrangement (Special Flat Cable signal wires are connected in order, with the communications power supply connected to the lower two pins.)

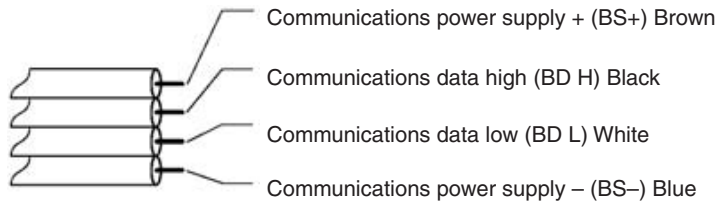

Communications Cable Crimp Terminals

The following table shows the recommended crimp terminals for the signal wires connected to the communications connector. Use either of the following cable crimp terminals.

Model	Manufacturer
AI-series AI0.75-8GY (product code 3200519)	Phoenix Contact
H0.75/14 (product code 046290)	Weidmuller Co., Ltd.

Insert the cable into the crimp terminal and crimp the end section.

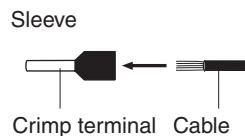

Use the following crimping tools.

Model	Manufacturer
UD6 (product code 1204436) or ZA3 Series	Phoenix Contact
PZ1.5 Crimper (product code 900599)	Weidmuller

Preparing and Connecting Communications Cables

Use the following procedure to connect the communications data/communications power supply to the connector.

- Note**
1. Always turn OFF the Master's power supply and communications power supply before connecting or disconnecting the communications data/communications power supply
 2. Use a dedicated communications connector.

Screwless Connector

Install the screwless communications connector in the Master Unit and then prepare as follows:

- 1,2,3...**
1. Remove sufficient (approx. 10 mm) insulation from the signal wires for a crimp terminal, and twist the exposed wire strands together tightly.

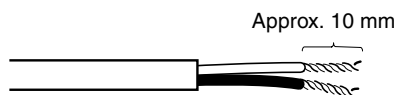

- Note** If using VCTF cable, cover the severed end of the insulation with vinyl tape or heat-shrinking tube.



2. After installing the crimp terminal to the stripped end of the signal wires, apply vinyl tape or heat-shrinking tube. The signal wires of the CJ-series Master Unit's communications connector can be connected without using crimp terminals.

- Note** Always use the specified crimping tool to install crimp terminals. When a crimping tool is not used, the terminal cannot be correctly crimped and may cause the cables to be disconnected.

3. Check the direction of the connector and insert each of the signal wires securely into the back of the connector holes. (The signal wires are fixed, so a tool is not required to secure them.)
If crimp terminals are not installed on the signal wires, use a small flat-

blade screwdriver to push down the orange tab on the connector and push in the signal wire.

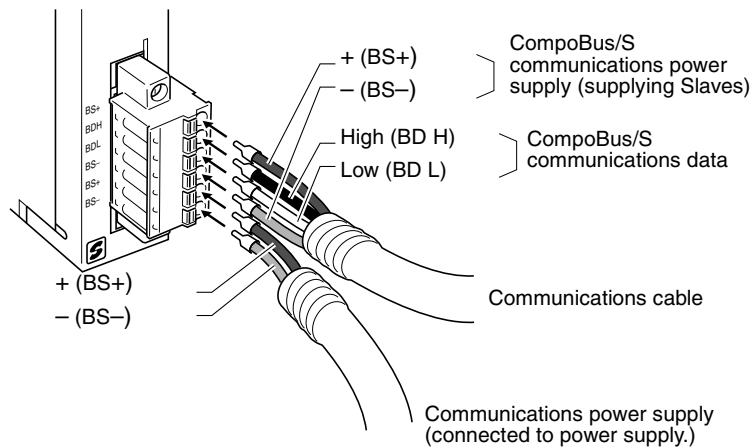

Note To disconnect the signal wires from a screwless connector, push down on the orange tab and at the same time pull out the signal wire. (The signal wires can be easily removed while leaving the communications connector installed in the Master Unit.)

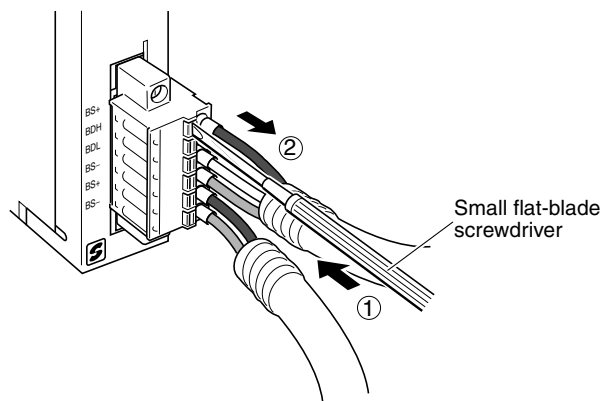

Check that the communications connector is securely fixed to the Master Unit. Tighten the communications connector to the specified tightening torque (0.25 to 0.3 N·m).

Connector with Screws

When using connectors with screws, remove the communications connector from the Master Unit and assemble the connector and cable according to the following procedure, as required. (If the Master Unit has sufficient space around it, the procedure can be followed while leaving the communications connector installed in the Master Unit.)

- 1,2,3...**
1. Remove sufficient (approx. 10 mm) insulation from the signal wires for a crimp terminal, and twist the exposed wire strands together tightly.



Note If using VCTF cable, cover the severed end of the insulation with vinyl tape or heat-shrinking tube.

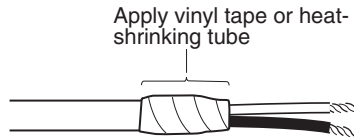

2. After installing the crimp terminal to the stripped end of the signal wires, apply vinyl tape or heat-shrinking tube.

Note Always use the specified crimping tool to install crimp terminals. When a crimping tool is not used, the terminal cannot be correctly crimped and may cause the cables to be disconnected.

3. Check the direction of the connector and insert each of the signal wires securely into the back of the connector holes.

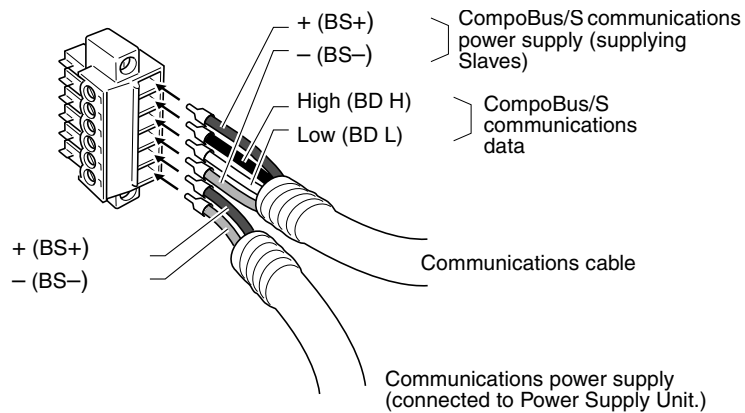

Note Before inserting the signal wires, check that the connector's lock screws are sufficiently loose. If the screws are not loose when the signal wires are inserted, the signal wires will enter the gap at the back of the connector rather than the side to be tightened and may not be secured.

4. Tighten the signal wires securely using the connector's signal wire lock screws. A standard screwdriver that is only slim at the end cannot be inserted into the back of the screw hole, so use a small flat-blade screwdriver that is of uniform thickness. The tightening torque is 0.22 to 0.25 N·m.

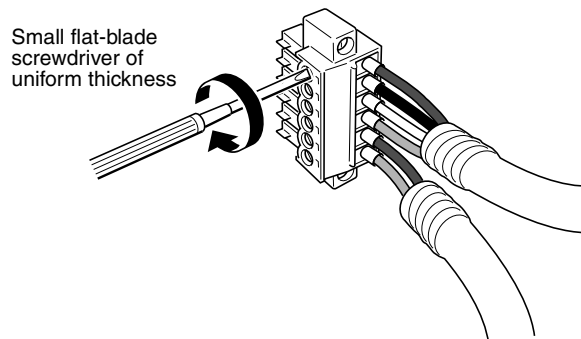

Note Use a precision flat-blade screwdriver and M2 size terminal screws for the communications connector.

- Connect the communications cable connector to the Master Unit, as shown in the following diagram.

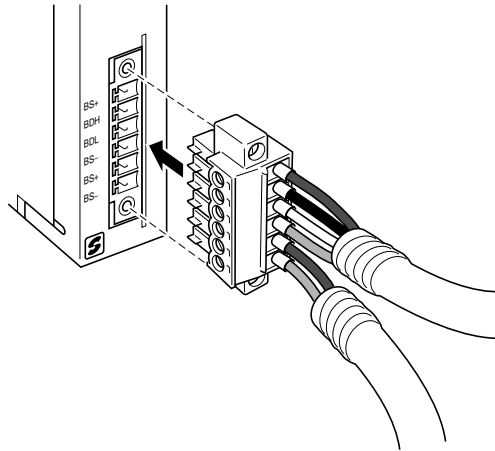

- Tighten the connector screws and secure the connector to the Master Unit. The tightening torque is 0.25 to 0.3 N·m.

4-3-4 I/O Allocations

CJ-series Master Units are allocated words for Slave I/O data and status flags in the Special I/O Unit Area of the Master. Words in the Special I/O Unit DM Area is allocated for the Slave registration function and communications stop mode.

Allocations and Master Unit Settings

The areas used by the Master Unit depend on the Master Unit settings, as shown in the following table.

Setting at Master Unit	Status	Affect on allocation
Usable node number settings (DIP switch pin 1)	OFF	Uses 10 words (words for one unit) from the Special I/O Unit Area as follows: Output: 4 words, input: 4 words, status: 2 words. (100 words are allocated in the Special I/O Unit DM Area)
	ON	Uses 20 words (words for two units) from the Special I/O Unit Area as follows: Output: 8 words, input: 8 words, status: 4 words. (100 words are allocated in the Special I/O Unit DM Area)
Special I/O Unit number setting (rotary switch)	n	First word of the area used in the Special I/O Unit Area is CIO 2000 + (n×10) words First word of the area used in the Special I/O Unit DM Area is D20000 + (n×100) words

Slave Allocations

Slaves are allocated in the Special I/O Unit Area as shown in the following diagram. In CompoBus/S Systems, node numbers of Input Slaves and Output Slaves are treated separately so the same number can be allocated.

I/O Allocations when Pin 1 Is OFF

When pin 1 is OFF and node addresses IN0 to IN7 and OUT0 to OUT7 (64 inputs/64 outputs max) are used, words are allocated to the Slaves for each node number as shown in the following diagram.

Special I/O Unit Area in Master PLC

First word	
CIO 2000	Unit number 0
CIO 2010	Unit number 1
CIO 2020	Unit number 2
CIO 2030	Unit number 3
CIO 2040	Unit number 4
CIO 2050	Unit number 5
CIO 2060	Unit number 6
CIO 2070	Unit number 7
~	
CIO 2920	Unit number 92
CIO 2930	Unit number 93
CIO 2940	Unit number 94
CIO 2950	Unit number 95

Slave allocations in Special I/O Unit Area

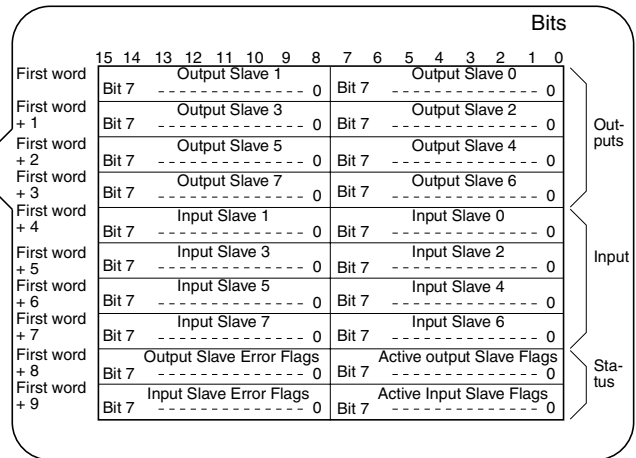

I/O Allocations when Pin 1 is ON

When pin 1 is ON and node addresses IN0 to IN15 and OUT0 to OUT15 (up to 128 inputs/128 outputs) are used, words are allocated to the Slaves for each node number as shown in the following diagram.

Special I/O Unit Area in Master PLC

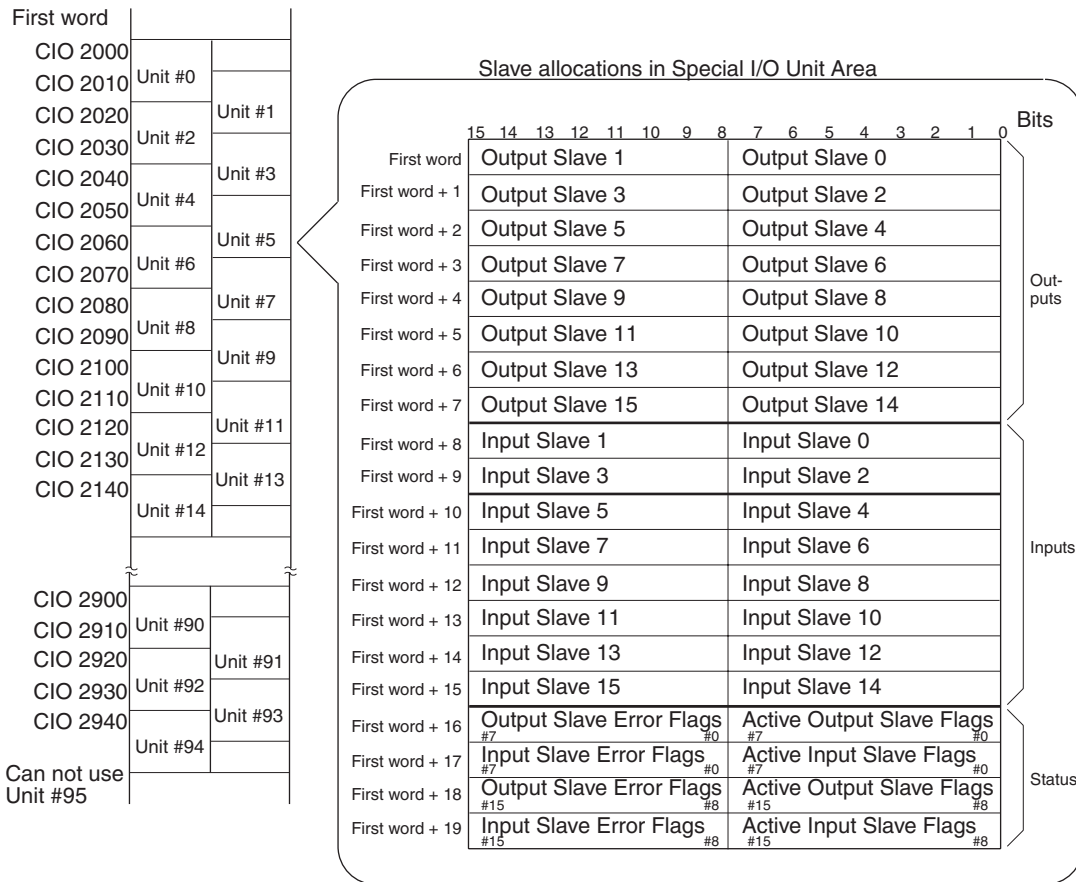

Slave I/O and Corresponding Areas

Slave with 8 Inputs or 8 Outputs

The Slave is treated as one node number for output or input.

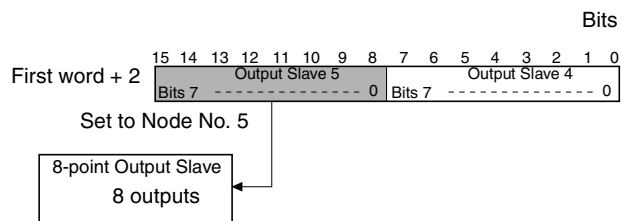

Slave with 16 Inputs or 16 Outputs

The Slave is treated as two node numbers for output or input, and allocated in the same words as follows:

- When an odd node number has been set:
Uses node number setting – 1 and node number setting
- When an even node number has been set:
Uses node number setting and node number setting + 1.

Example: When a 16-point Output Slave set as node number 5, the areas for Output Slaves 4 and 5 are used. Other Output Slaves cannot use the area allocated for Output Slave 4.

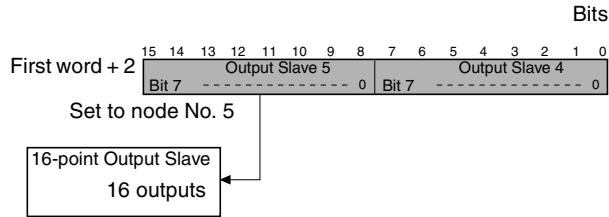

Slave with Mixed I/O (8 Inputs and 8 Outputs)

Slaves that have both outputs and inputs are also assigned a single node number, so the same node number is used for both outputs and inputs.

Example: When a Slave with 8 inputs and 8 outputs set as node number 2, the area for node number 2 outputs and inputs is used.

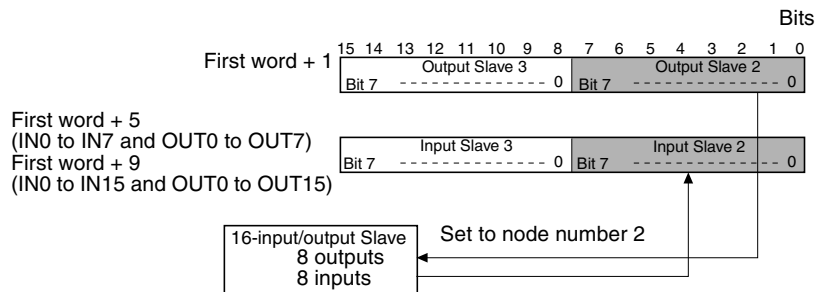

Slave with 4 Outputs or 4 Inputs

The Slave is treated as one node number for output or input. The Slave uses the rightmost 4 bits only, however, of the area allocated for one node number. (The leftmost 4 bits cannot be used by another Slave.)

- When an odd node number has been set:
Bits 8 to 11 are used and bits 12 to 15 are not used.
- When an even node number has been set:
Bits 0 to 3 are used and bits 4 to 7 are not used.

Example: When a Slave with 4 inputs is set as node number 7, the Slave is allocated the rightmost 4 bits (bits 8 to 11) in the area assigned for input node number 7.

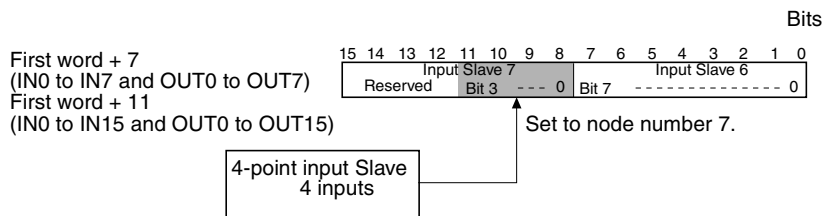

Slave with Mixed I/O (4 Outputs and 4 Inputs)

Slaves that have both outputs and inputs are also assigned a single node number, so the same node number is used for both outputs and inputs. The Slave uses the rightmost 4 bits only, however, of the area allocated for one node number. (The leftmost 4 bits cannot be used by another Slave.)

- When an odd node number has been set:
Bits 8 to 11 are used and bits 12 to 15 are not used.

- When an even node number has been set:
Bits 0 to 3 are used and bits 4 to 7 are not used.

Example: When a Slave with 4 outputs and 4 inputs is set to node number 2, the rightmost 4 bits (bits 0 to 3) of the area for node number 2 for both output and input are used.

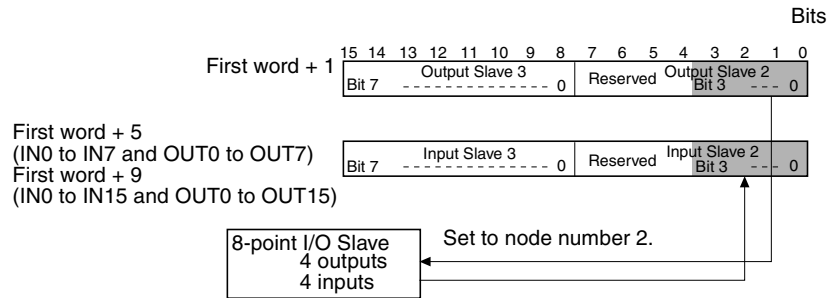

Slave with 32 Outputs or 32 Inputs

The Slave is treated as four node numbers for output or input and is allocated 2 consecutive words, as follows:

- When an odd node number has been set:
Uses (node number setting – 1) to (node number setting + 2)
- When an even node number has been set:
Uses (node number setting) to (node number setting + 3).

Example: When a Slave with 32 outputs is set to node number 1, it uses the area assigned for Output Slave 0 to Output Slave 3. The area for Output Slave 0, 2, and 3 cannot be used for another Output Slave.

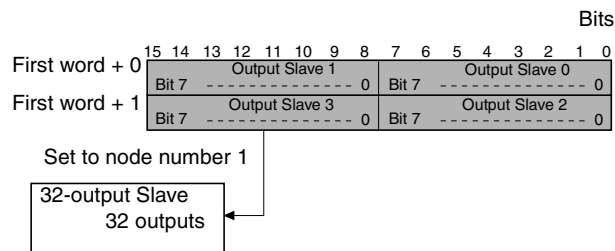

Slave with Mixed I/O (16 Outputs and 16 Inputs)

Slaves that have both outputs and inputs are also assigned a single node number, so the same node number is used for both outputs and inputs, and each is regarded as two node numbers. Outputs and inputs are allocated to the same words, as follows:

- When an odd node number has been set:
Uses (node number setting – 1) and (node number setting)
- When an even node number has been set:
Uses (node number setting) and (node number setting + 1).
- Example: When a Slave with 16 inputs and 16 outputs is set to node number 3, it uses Output Slave 2 and 3, and Input Slave 2 and 3. Output Slave 2 and Input Slave 2 cannot be used by other Slaves.

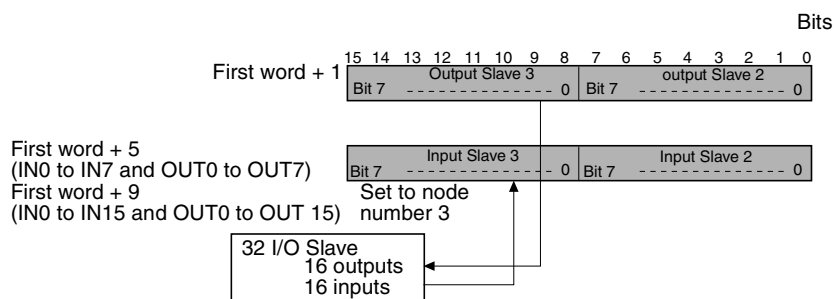

Using an Analog Terminal

An Analog Terminal uses 16, 32, 48, or 64 points. I/O allocations are shown in the following table.

Number of points allocated	Node number setting	Node numbers used
64 points SRT2-AD04: 4 inputs	Odd number	Node number setting – 1 to node number setting + 6
	Even number	Node number setting to node number setting + 7
48 points SRT2-AD04: 3 inputs	Odd number	Node number setting – 1 to node number setting + 4
	Even number	Node number setting to node number setting + 5
32 points SRT2-AD04: 2 inputs SRT2-DA02: 2 outputs	Odd number	Node number setting – 1 to node number setting + 2
	Even number	Node number setting to node number setting + 3
16 points SRT2-AD04: 1 input SRT2-DA02: 1 output	Odd number	Node number setting – 1 to node number setting
	Even number	Node number setting to node number setting + 1

Do not use words for the node number outside the words allocated in the Master Unit. If words outside the specified output or input areas are used, the Unit cannot participate in communications and the COMM indicator will not turn ON.

Status Flag Functions

The functions of the flags in the status area are described below.

- Active Output Slave Flags

These flags indicate which Output Slaves (0 to 15) are active nodes in the system. When the corresponding flag is ON, the Slave is an active node. All of these flags are reset when the power is turned ON or operation is restarted.

0 (OFF): No communications participation
 The node hasn't participated in communications even once.

1 (ON): Communications participation
 The flag won't change even if the node is withdrawn from the system.
- Active Input Slave Flags

These flags indicate which Input Slaves (0 to 15) are active nodes in the system. When the corresponding flag is ON, the Slave is an active node. All of these flags are reset when the power is turned ON or operation is restarted.

0 (OFF): No communications participation
 The node hasn't participated in communications even once.

1 (ON): Communications participation

The flag won't change even if the node is withdrawn from the system.

- Output Slave Error Flags

These flags indicate the communications status of the Output Slaves (0 to 15). All of these flags are reset when the power is turned ON or operation is restarted.

0 (OFF): Communications normal or inactive node

1 (ON): Withdrawn from communications (communications error)

- Input Slave Error Flags

These flags indicate the communications status of the Input Slaves (0 to 15). All of these flags are reset when the power is turned ON or operation is restarted.

0 (OFF): Communications normal or inactive node

1 (ON): Withdrawn from communications (communications error)

- Note**
1. When the CompoBus/S System starts up, inputs from Input Slaves and outputs to Output Slaves become effective when the Active Slave Flag for the Slave is turned ON. It is recommended to write a ladder program that verifies that the Slave's Active Slave Flag is ON and its Error Flag is OFF before transmitting or receiving I/O data.
 2. When CJ-series Master Units are set to communications stop mode, communications will stop when the Output Slave Error Flag or Input Slave Error Flag will turn ON. (Refer to 4-3-5 *Slave Registration Function and Communications Stop Mode*.)

4-3-5 Slave Registration Function and Communications Stop Mode

The CJ-series Master Units now support a Slave registration function and communications stop mode. This new capability enables the CompoBus/S System to deliver increased reliability.

Slave Registration Function

The words allocated in the DM Area to the Master Unit as a Special I/O Unit contains a Slave registration table. By registering the Slaves that are normally participating in communications, the Slaves that are not joined to the network or are slow to join, or unregistered Slaves that are illegally joined can be monitored.

This function prevents system malfunctions due to incorrect wiring on site. The Slave registration function is enabled by turning ON pin 4 of the DIP switch on the Master Unit.

Communications Stop Mode

By setting communications stop mode, remote I/O communications will stop when a communications error occurs, and information on the Slave with the communications error is stored in the Special I/O Unit DM Area.

This function prevents the System from running on incorrect I/O data without having to disconnect a Slave with a communications error, and enables quick troubleshooting of the communications error.

When remote I/O communications are stopped in communications stop mode, they will not resume when the cause of the error is removed. To restart remote I/O communications, turn ON the power again, or restart the Unit. When the Unit is set to standard communications mode, even if a communications error occurs, the remote I/O communications will continue with the Slave with the error disconnected. Also, the Slave with the communications error is not

recorded in the Special I/O Unit DM Area, so a standard status area check using the program is required.

If a verification error occurs while using the Slave registration function, as it is not a communications error, remote I/O communications will continue even if communications stop mode is enabled.

Communications stop mode is set using pin 3 of the DIP switch on the Master Unit. (pin 3 ON: communications stop mode, pin 3 OFF: normal communications mode)

Words Allocated for Slave Registration and Communications Stop Mode

The words used for the Slave registration function and communications stop mode are allocated in the Special I/O Unit DM Area according to the Master Unit's Special I/O Unit number, as shown below.

First word = D20000 + (unit number × 100)

	15	14	13	12	11	10	9	8	7	6	5	4	3	2	1	0	Bit
First word	Output Slave Registration Table (Used only when Slave registration function is enabled.)																CPU Unit-to-Master Unit (The contents of this area is transferred to the Master Unit from the CPU Unit when the power is turned ON. When the contents has changed, turn ON the power again.)
First word + 1	Input Slave Registration Table (Used only when Slave registration function is enabled.)																
First word + 2	Registered Slave Participation Monitoring Time (Used only when Slave registration function is enabled.)																
First word + 3	Reserved for system use (Cannot be used.)																
First word + 4	Status Flags (Used when Slave registration or communications stop mode are enabled.)																Master Unit-to-CPU Unit
First word + 5	Communications Stopped Node Number and Slave Type (Used only when communications stop mode is enabled.)																
First word + 6	Output Slave Verification Error: Slave Missing (Used only when Slave registration function is enabled.)																
First word + 7	Input Slave Verification Error: Slave Missing (Used only when Slave registration function is enabled.)																
First word + 8	Output Slave Verification Error: Unregistered Slave in Network (Used only when Slave registration function is enabled.)																
First word + 9	Input Slave Verification Error: Unregistered Slave in Network (Used only when Slave registration function is enabled.)																
First word + 10 to First word + 99	Not used. (Can be used as work bits/words.)																

The contents from the first word to the first word +9 cannot be used for any other purpose. They can be used, however, if the Slave registration function and communications stop mode are not enabled.

The functions of each area are given in the following table.

Word	Bit	Name	Function		
+0	00	Output Slave Registration Table	OUT0	Registers a list of the Output Slaves that are normally operating in the network. This list is used for checking the Slaves with the Slave registration function. Bits 00 to 15 correspond to Slave node numbers 0 to 15. The Output Slave is registered by turning ON its corresponding bit.	The bits in the Special I/O Unit Area must be registered to correspond to the node numbers actually used by the Slaves. Therefore, for Slaves with 16 points or higher, turn ON the bits for the other node numbers too. For example, the two consecutive bits used by a 16-point Slave or the four consecutive bits used by a 32-point Slave must be set.
	01		OUT1		
	02		OUT2		
	to		to		
	13		OUT13		
	14		OUT14		
	15		OUT15		
+1	00	Input Slave Registration table	IN0	Registers a list of the Input Slaves that are normally operating in the network. This list is used to check the Slaves with the Slave registration function. Bits 00 to 15 correspond to Slave node numbers 0 to 15. The Input Slave is registered by turning ON its corresponding bit.	
	01		IN1		
	02		IN2		
	to		to		
	13		IN13		
	14		IN14		
	15		IN15		
+2	00 to 15	Registered Slave Participation Monitoring Time	The waiting time between when the Master Unit is started until the Slaves start to be checked using the Slave registration function. The time is set in increments of 1 ms as a hexadecimal. The setting range is 0000 (default is 2000 ms) or 0001 to FFDC (1 to 65500 ms). If the monitoring time lapses and there are still registered Slaves not joined in the network, a verification error (Slave missing) will occur.		
+3	00 to 15	Reserved for system use.			

Word	Bit	Name	Function
+4	00	Registration Completed Flag	This flag is turned ON when all registered Slaves have joined the network. If all the registered Slaves have joined the network within the registered Slave participation monitoring time this flag will turn ON even if unregistered Slaves have also joined. The flag will not turn ON, however, if there are no Slaves set in the Slave registration table. The flag will remain ON until the power is turned OFF and ON again or the Unit is restarted.
	00 to 07	Reserved for system use.	
	08	Verification Error Flag: Slave Missing	This flag is turned ON under the following conditions. Registered Slaves do not join the network within the registered Slave participation monitoring time. When the Slave that caused the verification error is joined in the network, the flag will automatically be turned OFF. Check which Slave caused the error in the bit for verification error (Slave missing) in Output Slave (first word + 6) or verification error (Slave missing) in Input Slave (first word + 7).
	09	Verification Error Flag: Unregistered Slave in Network	This flag is turned ON when an unregistered Slave has joined the network. The flag will remain ON until the power is turned OFF and ON again or the Unit is restarted, even if the Slave that caused the verification error is removed from the network. Check which Slave caused the error in the bit for Output Slave verification error (unregistered Slave in network) (first word + 8) or Input Slave verification error (unregistered Slave in network) (first word + 9).
	10	Communications Stopped Flag	This flag is turned ON when the Master Unit is set to communications stop mode and remote I/O communications stop due to a communications error. Once the flag has turned ON, the status remains until the power is turned OFF and ON again or the Unit is restarted. Check which Slave caused the error in the bits for communications stopped node number (bits 00 to 07 of first word + 5) and communications stopped Slave type (bit 15 of first word + 5).
	11 to 14	Reserved for system use.	
	15	Error Flag	This flag is turned ON when any of the bits 08 to 10 are set to 1 (ON). The flag is automatically turned OFF when all the bits 08 to 10 are turned OFF.
+5	00 to 07	Communications Stopped Node Number	When the Master Unit is set to communications stop mode and remote I/O communications stop due to a communications error, the node number of the Slave that caused the error is stored as a 2-digit hexadecimal (00 to 0F: 1 to 15). Check the Slave type (Output or Input) in the word for communications stopped Slave type (bit 15 of first word + 5). The node address stored will be held until the power is turned OFF and ON again or the Unit is restarted.
	08 to 14	Reserved for system use.	
	15	Communications Stopped Slave type	When the Master Unit is set to communications stop mode and remote I/O communications stop due to a communications error, the Slave type of the Slave that caused the error is stored as follows: 0 (OFF): Output Slave 1 (ON): Input Slave Check which Slave caused the error in the bits for communications stopped node number (bits 00 to 07 of first word + 5) When communications have stopped, the bit status is held until the power is turned OFF and ON again or the Unit is restarted.

Word	Bit	Name	Function		
+6	00	Output Slave Verification Error: Slave Missing	OUT0	When the Slave registration function is enabled, the bit corresponding to the node number of the Output Slave that caused the verification error (Slave missing) will be turned ON. Bits 00 to 15 correspond to Output Slave node numbers 1 to 15. When the Slave that caused the verification error joins the network, the bit will automatically turned OFF.	The bits in the Special I/O Unit Area correspond to the node numbers actually used by the Slaves. Therefore, for Slaves with 16 points or higher, the bits other than those set for the node number may also be turned ON. For example, the two consecutive bits used by a 16-point Slave or the four consecutive bits used by a 32-point Slave may be turned ON at the same time.
	01		OUT1		
	02		OUT2		
	to		to		
	13		OUT13		
	14		OUT14		
	15		OUT15		
+7	00	Input Slave Verification Error: Slave Missing	IN0	When the Slave registration function is enabled, the bit corresponding to the node number of the Input Slave that caused the verification error (Slave missing) will be turned ON. Bits 00 to 15 correspond to Input Slave node numbers 1 to 15. When the Slave that caused the verification error joins the network, the bit will automatically turned OFF.	
	01		IN1		
	02		IN2		
	to		to		
	13		IN13		
	14		IN14		
	15		IN15		
+8	00	Output Slave Verification Error: Unregistered Slave in Network	OUT0	When the Slave registration function is enabled, the bit corresponding to the node number of the Output Slave where a verification error (unregistered Slave in network) will be turned ON. Bits 00 to 15 correspond to Output Slave node numbers 1 to 15. Once a bit has been turned ON the status will be held until the power is turned OFF and ON again or the Unit is restarted.	
	01		OUT1		
	02		OUT2		
	to		to		
	13		OUT13		
	14		OUT14		
	15		OUT15		
+9	00	Input Slave Verification Error: Unregistered Slave in Network	IN0	When the Slave registration function is enabled, the bit corresponding to the node number of the Input Slave where a verification error (unregistered Slave in network) will be turned ON. Bits 00 to 15 correspond to Input Slave node numbers 1 to 15. Once a bit has been turned ON the status will be held until the power is turned OFF and ON again or the Unit is restarted.	
	01		IN1		
	02		IN2		
	to		to		
	13		IN13		
	14		IN14		
	15		IN15		

Slave Registration Function Procedure

When the Slave registration function is used, the Output/Input Slave registration table and registered Slave participation monitoring time must be set in the Special I/O Unit DM Area, but the power must be turned OFF and ON again or the Unit restarted to enable the settings.

The following example shows the procedure for using the Slave registration function. (Information on other Slave registration function settings and connections are omitted here.)

- 1,2,3...**
1. Turn OFF pin 4 of the DIP switch on the Master Unit to disable the Slave registration function.
 2. Turn ON the power to the CPU Unit to which the Master Unit is mounted.
 3. Use a Programming Device for the CPU Unit to set the following information in the Special I/O Unit DM Area words used by the Master Unit.
 - Output Slave registration table
 - Input Slave registration table
 - Registration Slave participation monitoring time
 4. Turn OFF the power to the CPU Unit to which the Master Unit is mounted.
 5. Turn ON pin 4 of the DIP switch on the Master Unit to enable the Slave registration function
 6. Turn ON the power to the CPU Unit to which the Master Unit is mounted or restart the Master Unit.

The settings in the Special I/O Unit DM Area can be set while pin 4 of the DIP switch on the Master Unit is set to ON, but a verification error may occur due to the incorrectly set Slave registration table.

4-3-6 Allocations for Master Unit in PLC

The following table shows the words in the CPU Unit that are related to the Master Unit.

Data area	Bit(s)	Name	Function
Auxiliary Area (A)	A33000 to A33015	Special I/O Unit Restarting Flags	These flags are turned ON while a Special I/O Unit is restarting. Each bit corresponds to the Unit with the same unit number.
	A40113	Dual Number Use Error Flag (Fatal Error)	This flag is turned ON in the following situations: When the same unit number has been set on more than one CS1 CPU Bus Unit. When the same unit number has been set on more than one Special I/O Unit. When the same word is allocated more than once for Basic I/O Units.
	A40206	Special I/O Unit Error Flag	This flag is turned ON when the same unit number has been set on more than one Special I/O Unit, or when an error has occurred during data transfer between the PLC and the Special I/O Unit. The unit number of the Unit is written to word A418.
	A41100 to A41115	Special I/O Unit Number Duplication Flags	These flags are turned ON when the same unit number has been set on more than one Special I/O Unit (i.e., when A40113 is ON). Each bit corresponds to the Unit with the same unit number.
	A41800 to A41815	Special I/O Unit Error Flags	These flags are turned ON when the same unit number has been set on more than one Special I/O Unit, or when an error has occurred during data transfer between the PLC and the Special I/O Unit. Each bit corresponds to the Unit with the same unit number.
	A50200 to A50215	Special I/O Unit Restart Bits	Turn the corresponding bit ON and then OFF to restart a Special I/O Unit. Each bit corresponds to the Unit with the same unit number.
PLC Setup	22600 to 22615	Special I/O Unit Refresh Disable Bits	Turn the corresponding bit ON to disable refreshing of the corresponding Special I/O Unit (except those on Slave Racks).

4-4 CQM1-SRM21-V1 Master Unit for CQM1 PLCs

4-4-1 Specifications and Part Names

Specifications

General Specifications

General specifications conform to those of the SYSMAC CQM1 and CQM1H PLCs.

Performance Specifications

Item	Specifications
Model	CQM1-SRM21-V1
Unit classification	Special I/O Unit
Internal current consumption	5 V DC, 180 mA max.
Weight	200 g max.
Max. number of Masters	CQM1 PLC: 1 Master Unit CQM1H PLC: Up to the maximum number of I/O points that can be connected to the CPU Unit.
Master Unit mounting location	No restrictions.
Max. number of I/O points per Master	CQM1-CPU11/21: 32 points (16 inputs/16 outputs) or 64 points (32 inputs/32 outputs) CQM1-CPU41/42/43/44-V1 or CQM1H: 32 points (16 inputs/16 outputs), or 64 points (32 inputs/32 outputs), or 128 points (64 inputs/64 outputs) (Switch using DIP switch setting) Uses the I/O Area in the CPU Unit.
Number of points per node number	8 or 4 points
Number of usable node numbers per Master	8 points per node number: IN0 to IN1 and OUT0 to OUT1, or IN0 to IN3 and OUT0 to OUT 3, or IN0 to IN7 and OUT0 to OUT7 4 points per node number: IN0 to IN3 and OUT0 to OUT 3, or IN0 to IN7 and OUT0 to OUT7, or IN0 to IN15 and OUT0 to OUT15

Alarm Output Specifications

Item	Specification
Maximum switching capacity	2 A (24 V DC)
Minimum switching capacity	10 mA (5 V DC)
Relay type	G6D-1A
Minimum ON time	100 ms (Outputs are ON at least 100 ms.)
Circuit configuration	

Caution For conformance to the EC Directives (Low-voltage Directives), provide reinforced insulation or double insulation for the power source that is used for the alarm output.

Dimensions

The following diagram shows the dimensions of the CQM1-SRM21-V1 Master Unit. All dimensions are in mm.

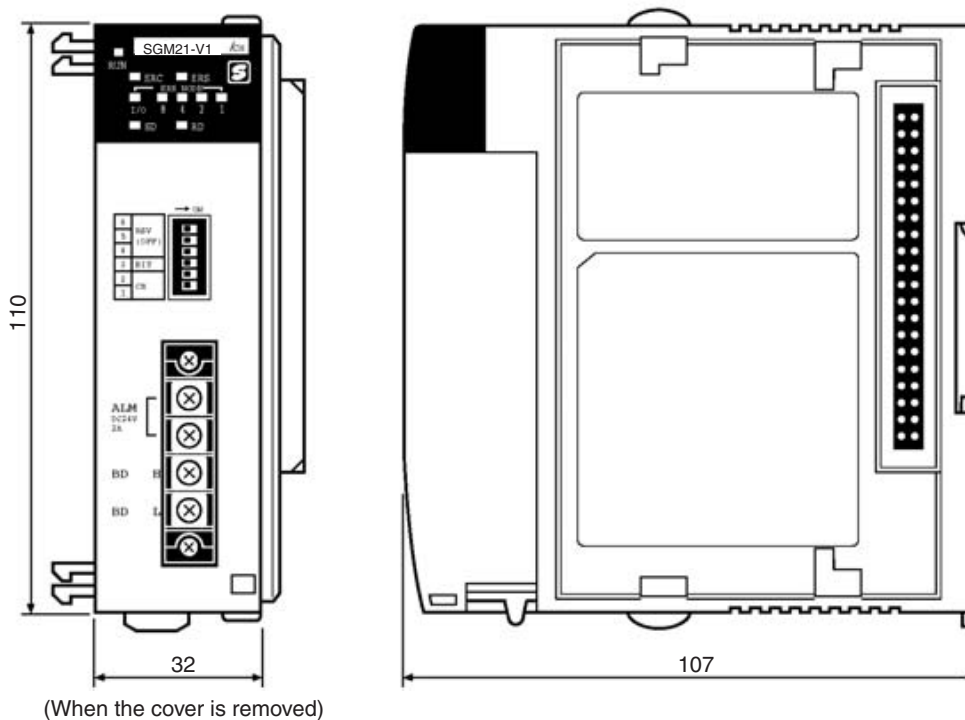

Note Refer to the *CQM1 Operation Manual (W226)* for details on the dimensions when the Master Unit is installed.

Master Unit Components

The following diagram shows the main components of the CQM1-SRM21-V1 Master Unit. The functions of these components are described below.

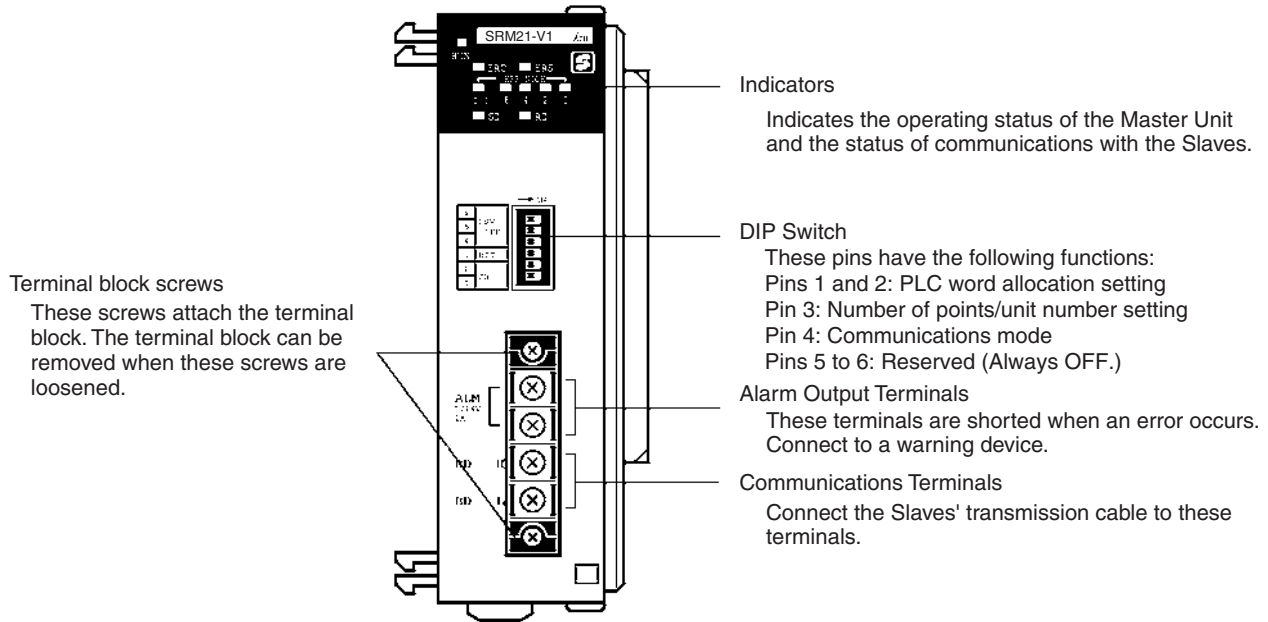

Indicators

The following table shows the meaning of the indicators.

Indicator	Status	Meaning
RUN (green)	ON	The Unit is operating normally.
	OFF	Indicates one of the following conditions: The power is OFF, there is an I/O UNIT OVER error, or there is an I/O Bus error.
SD (yellow)	ON	Data is being transmitted.
	OFF	Data is not being transmitted.
RD (yellow)	ON	Data is being received.
	OFF	Data is not being received.
ERC (red)	ON	A Slave has been withdrawn from communications. (Communications error)
	OFF	The Slaves are communicating normally.
ERS (red)	ON	The data areas between the Slaves overlaps when the number of points/unit number setting is set to 4-point mode.
	Flashing	A node number is out-of-range, as follows: (The Unit doesn't check for node numbers 8 or higher.) The PLC is allocated 2 words and the number of points/unit number is set to 8-point mode, but the node number is 2 to 7. The PLC is allocated 4 words and the number of points/unit number is set to 8-point mode, but the node number is 4 to 7. The PLC is allocated 2 words and the number of points/unit number is set to 4-point mode, but the node number is 4 to 7.
	OFF	The data area and address settings are correct.

Indicator	Status	Meaning
IN/OUT (red)	ON	An error has occurred with an Output Slave.
	OFF	An error has occurred with an Input Slave or all Slaves are operating normally.
8421 (red)	ON/OFF	These indicators represent the four-digit binary slave number of the Slave in which the error occurred.

4-4-2 Switch Settings

DIP Switch

The DIP switch is used to make the PLC word allocation setting and the number of points/unit number setting.

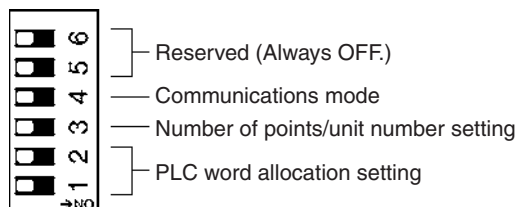

Set the PLC word allocations with pins 1 and 2, as shown in the following table. This is the total number of words allocated to Slaves in the PLC.

Pin 1	Pin 2	Max. number of Slaves setting
OFF	OFF	2 words (1 input word, 1 output word)
ON	OFF	4 words (2 input words, 2 output words)
OFF	ON	8 words (4 input words, 4 output words)
ON	ON	

- The Master Unit is shipped with pins 1 and 2 set to OFF (2 words).
- Word addresses are allocated separately for inputs and outputs. The words are allocated in order from the left of the PLC to the right, just like regular I/O Units.

Note Always turn OFF the PLC's Power Supply before changing the setting.

Caution Always set pin numbers 5 to 6 of the DIP switch to OFF.

Set the number of points/unit number with pin 3, as shown in the following table.

Pin 3	Number of I/O points/Unit number
OFF	8 points (8-point mode)
ON	4 points (4-point mode)

The following table shows all of the possible combinations of DIP switch settings.

Setting			PLC word allocation	Max. number of I/O points	Points/node number	Usable node numbers	Communications cycle time		Use of Analog Terminals
Pin 1	Pin 2	Pin 3					High-speed Communications Mode	Long-distance Communications Mode	
OFF	OFF	OFF	2 words (1 IN/1 OUT)	16 input points, 16 output points	8 points	IN: 0 and 1 OUT: 0 and 1	0.5 ms	4.0 ms	Possible (Only for Master Unit models with V1. Not possible for models without V1.)
ON	OFF	OFF	4 words (2 IN/2 OUT)	32 input points, 32 output points	8 points	IN: 0 to 3 OUT: 0 to 3	0.5 ms	4.0 ms	
OFF	ON	OFF	8 words (4 IN/4 OUT)	64 input points, 64 output points	8 points	IN: 0 to 7 OUT: 0 to 7	0.5 ms	4.0 ms	
ON	ON	OFF							
OFF	OFF	ON	2 words (1 IN/1 OUT)	16 input points, 16 output points	4 points	IN: 0 to 3 OUT: 0 to 3	0.5 ms	4.0 ms	Not possible
ON	OFF	ON	4 words (2 IN/2 OUT)	32 input points, 32 output points	4 points	IN: 0 to 7 OUT: 0 to 7	0.5 ms	4.0 ms	
OFF	ON	ON	8 words (4 IN/4 OUT)	64 input points, 64 output points	4 points	IN: 0 to 15 OUT: 0 to 15	0.8 ms	6.0 ms	
ON	ON	ON							

Note When the CQM1 Master Unit is used in 4-point mode, Slaves with 16 points or more cannot be used. If Slaves with 16 points or more are used, a data area overlap error (ERS indicator lit) will occur.

Set the communications mode with DIP switch pin 4 (DR), as shown in the following table.

Pin 4	Communications mode setting	Communications distance	Communications baud rate	Communications cycle time
OFF	High-speed Communications Mode	100 m max.	750 kbps	0.5 or 0.8 ms
ON	Long-distance Communications Mode	500 m max.	93.75 kbps	4.0 or 6.0 ms

- Note**
1. Make sure that the communications mode of the Master Unit is the same as that of all the Slaves. If the CompoBus/S System contains a Slave with a different communications mode, the COMM indicator on that Slave will not light, and normal communications with that Slave will not be possible. Other Slaves will not be adversely affected, and the COMM indicator on the Master Unit will light normally. For information relating to the states of the Master Unit indicator, refer to 6-5-1 *Indicators*.
 2. When using a previous Master Unit model (without V1), pin 4 must be set to OFF. Otherwise, normal communications may not be possible.
 3. Pin 4 is factory-set to OFF (High-speed Communications Mode).
 4. The settings for the communications distance, baud rate, and communications cycle time vary according to the setting of pin 4, as shown in the above table.

4-4-3 I/O Allocations in CQM1 PLCs

In CQM1 PLCs, the Master Unit is treated just like an I/O Unit that has both inputs and outputs, so the Slave's I/O data is stored in the words allocated to those inputs and outputs.

The group of words allocated to the Master is determined by the mounting position of the Master Unit, and the specific bits used by each Slave are determined by the node number set on the Slave.

- Master Units for CQM1 PLCs don't have the status area information that is provided with the Master Units for CS-series, C200HX/C200HG/C200HE-(Z)E, and C200HS PLCs.
- The following equation shows the maximum time required for inputs from the Input Slaves and outputs to the Output Slaves to become effective after the CompoBus/S System is turned ON.

In High-speed Communications Mode: (PLC cycle time) + 118 ms
 In Long-distance Communications Mode: (PLC cycle time) + 720 ms.

This delay must be taken into account when writing ladder programs for the PLC. It is recommended to write a routine in the ladder program that checks whether the alarm output terminal is OFF before processing I/O with the Slaves.

Master Unit Settings

The following settings affect I/O allocations to Slaves of the Master Units used with CQM1 PLCs.

PLC Word Allocation

In order for the Master Unit to allocate words to Slaves, the total number of words allocated to the Master Unit must be set in the PLC. The following three settings can be made:

- 2 words (1 input word, 1 output word)
- 4 words (2 input words, 2 output words)
- 8 words (4 input words, 4 output words)

Number of Points/Node Number

This setting determines the amount of memory (number of bits) allocated to each node number. The following two settings can be made:

- 8 points (8-point mode)
- 4 points (4-point mode)

Refer to the table on page 129 for details on the possible combinations of DIP switch settings.

Slave Allocations

The Slaves are allocated input and output words as shown below. In Compo-Bus/S Systems, the node numbers of Input Slaves and Output Slaves are handled separately so the same node numbers can be set for both one Input and one Output Slave.

I/O Allocations in 8-point Mode

PLC Word Allocation: 2 Words

The following diagram shows the I/O allocations when the DIP switch is set as shown below.

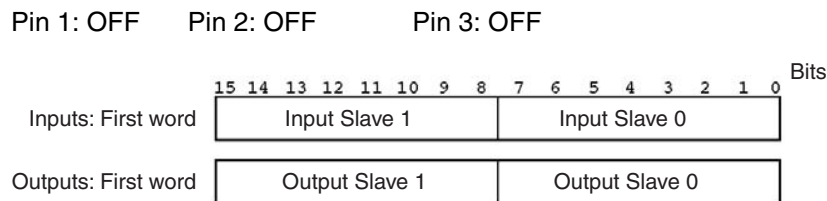

PLC Word Allocation: 4 Words

The following diagram shows the I/O allocations when the DIP switch is set as shown below.

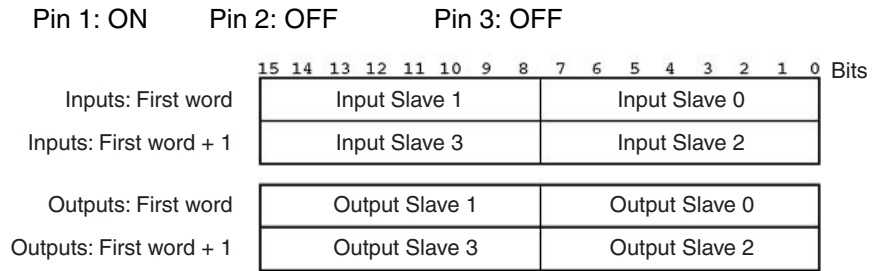

PLC Word Allocation: 8 Words

The following diagram shows the I/O allocations when the DIP switch is set as shown below.

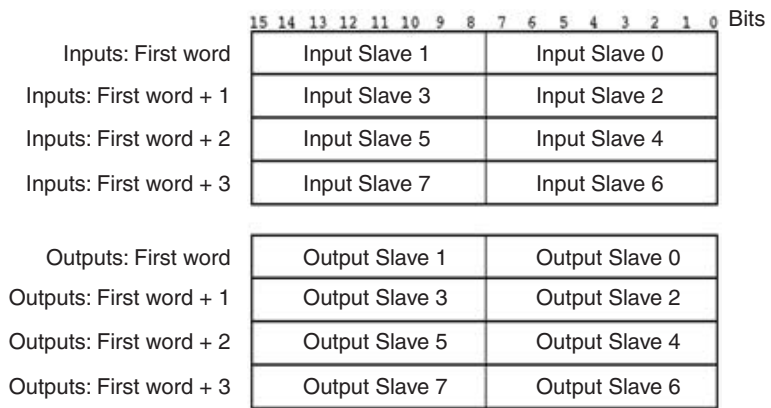
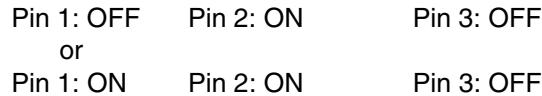

Note When the number of points/node number is set to 8-point mode, each 16-point Slave (input or output) is treated as 2 node numbers and those bits are allocated so that all 16 bits are in the same word, as described below.

When an odd node number has been set, the previous node number's allocated memory is also used.

When an even node number has been set, the next node number's allocated memory is also used.

For example, when a 16-output Slave's node number is set to 3, the Slave uses the bits for Output Slave 2 and Output Slave 3. When the node number is set to 0, the Slave uses the bits for Output Slave 0 and Output Slave 1.

The Slave with 4 inputs or 4 outputs is regarded as one Slave Unit.

When an odd node number has been set:
 Bits 8 to 11 are used and bits 12 to 15 are not used.

When an even node number has been set:
 Bits 0 to 3 are used and bits 4 to 7 are not used.

An Analog Terminal uses 64, 48, 32, or 16 points. For this reason, in 8-point mode, I/O allocations are as shown in the following table.

Number of points allocated	Node number setting	Node numbers used	Valid setting range		
			2 words allocated	4 words allocated	8 words allocated
64 points SRT2-AD04: 4 inputs	Odd number	Node number setting – 1 to node number setting + 6	Not possible	Not possible	0 to 1
	Even number	Node number setting to node number setting + 7			
48 points SRT2-AD04: 3 inputs	Odd number	Node number setting – 1 to node number setting + 4	Not possible	Not possible	0 to 3
	Even number	Node number setting to node number setting + 5			
32 points SRT2-AD04: 2 inputs SRT2-DA02: 2 outputs	Odd number	Node number setting – 1 to node number setting + 2	Not possible	0 to 1	0 to 5
	Even number	Node number setting to node number setting + 3			
16 points SRT2-AD04: 1-input SRT2-DA02: 1-output	Odd number	Node number setting – 1 to node number setting	0 to 1	0 to 3	0 to 7
	Even number	Node number setting to node number setting + 1			

If a node number is outside the setting range, the words allocated to the Slave will extend beyond the input or output area, which will prevent the Slave participating in communications. If this happens, the COMM indicator will not light.

Connector Terminals with 32 inputs or 32 outputs are allocated the words for four 8-point nodes, i.e., they are allocated two I/O words. Therefore, the following nodes will be used in addition to the set nodes. Connector Terminals with 16 inputs or 16 outputs will be allocated I/O as Slaves with 16 inputs or Slaves with 16 outputs for the node number setting.

Node number setting	Node numbers used	Valid setting range		
		2 words allocated	4 words allocated	8 words allocated
Odd number	Node number setting – 1 to node number setting + 2	Not possible	0 to 1	0 to 5
Even number	Node number setting to node number setting + 3			

If a node number is not within the setting range, the words allocated to the Slave will extend beyond the input or output area, which will prevent the Slave from participating in communications. If this happens, the COMM indicator will not light.

I/O Allocation Example (4 Words)

In this example the number of points/node number is set to 8, the PLC word allocations are set to 4 words, and the system has the configuration shown in the following diagram. (The node numbers are indicated by #0, #1, and #2.)

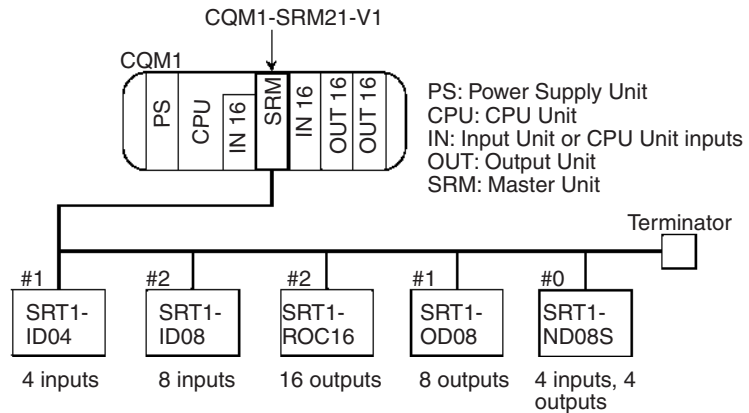

The I/O allocations for this system are shown below.

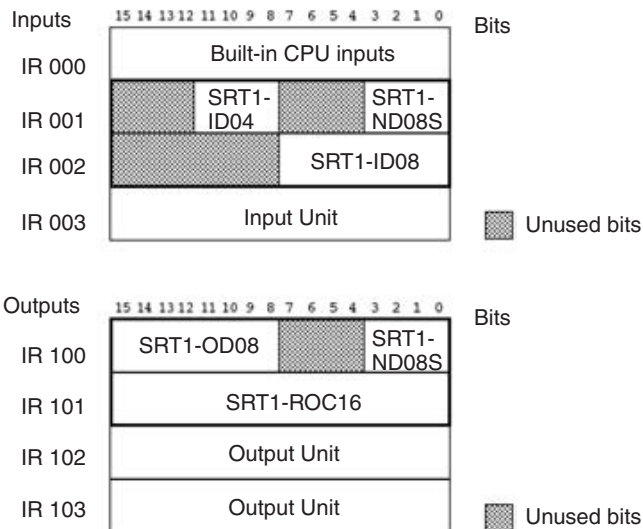

I/O Allocations in 4-point Mode

PLC Word Allocation: 2 Words

The following diagram shows the I/O allocations when the DIP switch is set as shown below.

Pin 1: OFF Pin 2: OFF Pin 3: ON

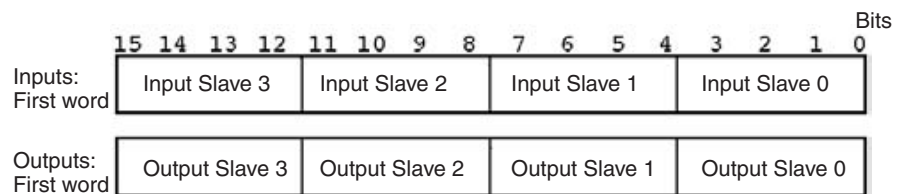

PLC Word Allocation: 4 Words

The following diagram shows the I/O allocations when the DIP switch is set as shown below.

Pin 1: ON Pin 2: OFF Pin 3: ON

	15	14	13	12	11	10	9	8	7	6	5	4	3	2	1	0	Bits
Inputs: First word	Input Slave 3				Input Slave 2				Input Slave 1				Input Slave 0				
Inputs: First word + 1	Input Slave 7				Input Slave 6				Input Slave 5				Input Slave 4				
Outputs: First word	Output Slave 3				Output Slave 2				Output Slave 1				Output Slave 0				
Outputs: First word + 1	Output Slave 7				Output Slave 6				Output Slave 5				Output Slave 4				

PLC Word Allocation: 8 Words

The following diagram shows the I/O allocations when the DIP switch is set as shown below.

Pin 1: OFF Pin 2: ON Pin 3: ON
 or
 Pin 1: ON Pin 2: ON Pin 3: ON

	15	14	13	12	11	10	9	8	7	6	5	4	3	2	1	0	Bits
Inputs: First word	Input Slave 3				Input Slave 2				Input Slave 1				Input Slave 0				
Inputs: First word + 1	Input Slave 7				Input Slave 6				Input Slave 5				Input Slave 4				
Inputs: First word + 2	Input Slave 11				Input Slave 10				Input Slave 9				Input Slave 8				
Inputs: First word + 3	Input Slave 15				Input Slave 14				Input Slave 13				Input Slave 12				
Outputs: First word	Output Slave 3				Output Slave 2				Output Slave 1				Output Slave 0				
Outputs: First word + 1	Output Slave 7				Output Slave 6				Output Slave 5				Output Slave 4				
Outputs: First word + 2	Output Slave 11				Output Slave 10				Output Slave 9				Output Slave 8				
Outputs: First word + 3	Output Slave 15				Output Slave 14				Output Slave 13				Output Slave 12				

In 4-point mode, 8-point Slaves use two node numbers.

Slave	Node number setting	Node number actually used
8-point Slave	Odd number	Node number setting to node number setting + 1
	Even number	

Example:

When the PLC word allocations are set to 8 words and an 8-output Slave's node number is set to 3, the Slave uses the words for Input Slave 3 and Input Slave 4.

I/O Allocation Example (2 Words)

In this example the number of points/node number is set to 4, the PLC word allocations are set to 2 words, and the system has the configuration shown in the following diagram. (The node numbers are indicated by #0, #1, #2, and #3.)

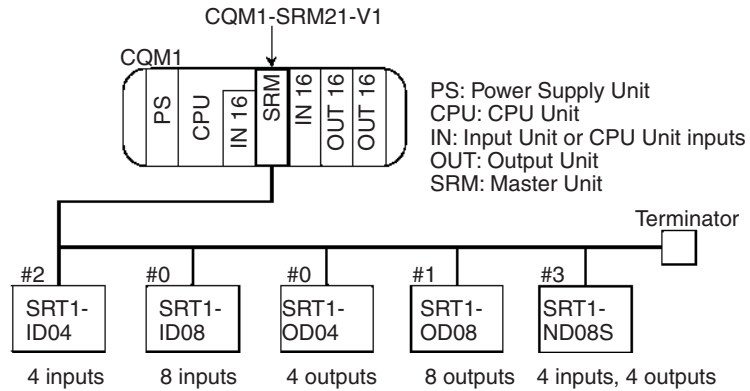

The I/O allocations for this system are shown below.

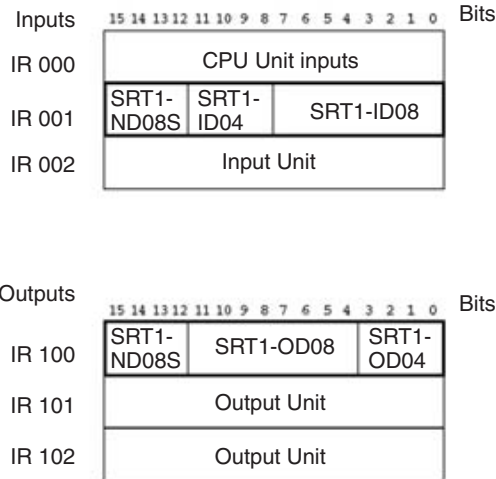

4-5 SRM1-C0□-V2 Master Control Units

The SRM1 Master Control Unit contains both CPU Unit and Master Unit and it connects to all I/O using CompoBus/S. This manual provides SRM1 specifications only. For details, refer to the *CompoBus/S SRM1(-V2) Master Control Unit Operation Manual (W318)*.

4-5-1 Specifications and Part Names

Specifications

Item	Specifications	
Model	SRM1-C01-V2	SRM1-C02-V2
Port	Peripheral port	Peripheral port RS-232C port

General Specifications

Item	Specifications
Power supply voltage	24 V DC
Allowable power supply voltage	20.4 to 26.4 V DC
Power consumption	3.5 W max.
Inrush current	12.0 A max.
Noise immunity	1500 Vp-p with a pulse width of 0.1 to 1 μ s and a rise time of 1 ns (via impulse noise simulator)
Vibration resistance	Conforming to JIS C0911: 10 to 57 Hz with single-amplitude of 0.075 mm 57 to 150 Hz with fixed acceleration of 9.8 m/s ² 10 sweeps each in X, Y, and Z directions (8 minutes per sweep \times 10 sweeps = 80 minutes)
Shock resistance	Conforms to JIS C0912 147 m/s ² 3 times each in X, Y, and Z directions
Ambient temperature	Operating: 0 to 55°C Storage: -20 to 75°C
Ambient operating relative humidity	10% to 90% (with no condensation)
Operating environment	No corrosive gases
Terminal screw size	M3
Power holding time	DC power: 2 ms min.
Weight	150 g max.

Master Specifications

Item	Specifications
I/O points	256 points (128 inputs/128 outputs) or 128 points (64 inputs/64 outputs) (Determined by the usable node number setting in DM. The default setting is 256 points.)
Number of points per node number	8-point mode
Usable node numbers	IN0 to IN15/OUT0 to OUT15 or IN0 to IN7/OUT0 to OUT7 (Can be switched with setting in DM.)
I/O words	Input: IR 000 to 007 Output: IR 010 to 017
Programming language	Ladder program
Instructions	14 basic instruction + 81 special instructions with 129 variations
Processing speed	LD instruction: 0.97 μ s, MOV instruction: 9.1 μ s
Program capacity	4,096 words
Data memory	2,022 words + 512 words (Read only)
Timers/Counters	128 total
Work bits	640
Memory backup	Flash memory: User programs, etc. (without battery) Lithium battery: Data memories, etc. (Battery life: 10 years or more at ambient temperature of 25°C)
Peripheral port	1 port

Item	Specifications
RS-232C port	1 port (SRM1-C02-V2 only) Host link, NT link, 1:1 PLC link, ASCII data transfer with XON, XOFF flow control
Programming Devices	Programming Console (CQM1-PR001-E/C200H-PR027-E) SYSMAC Support Software C500-ZL3AT1-E (for IBM PC/AT, English version)

Dimensions (Common)

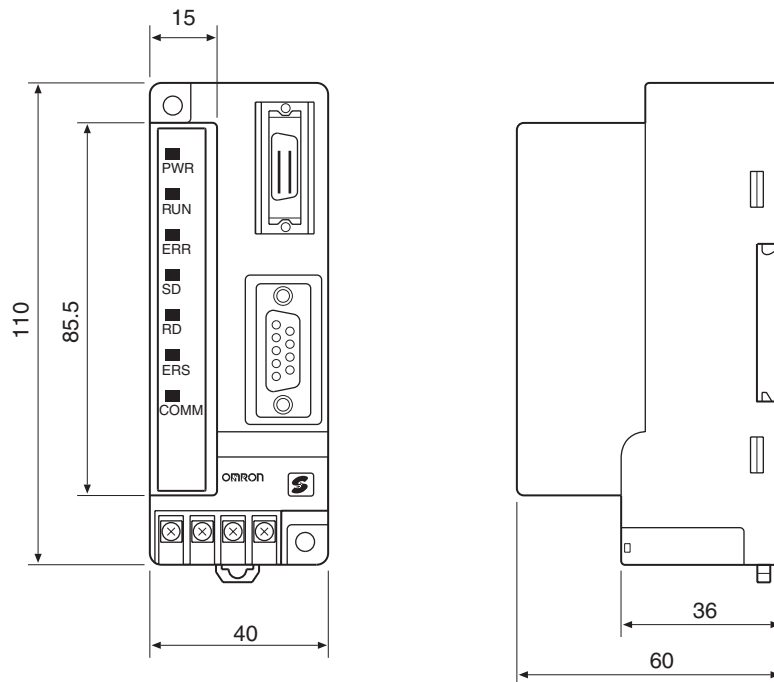

Mounting Holes

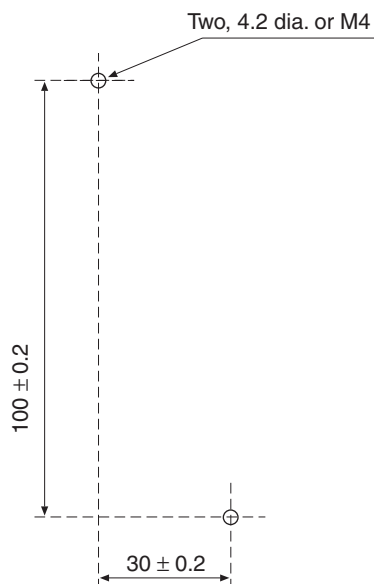

(Unit: mm)

Name and Function of Parts

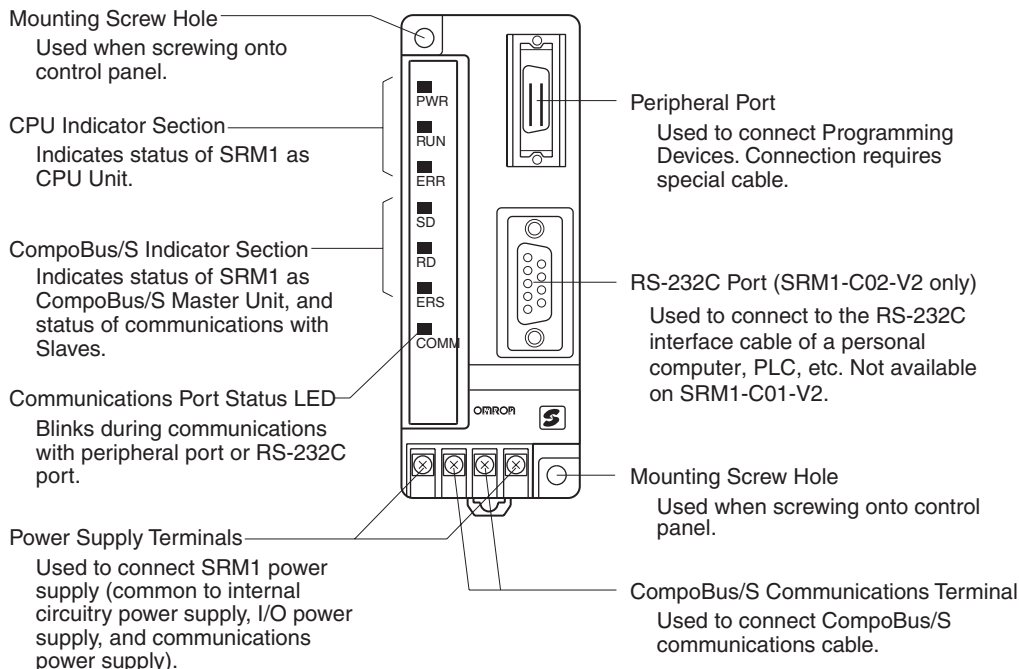

Indicators

The following table shows the meaning of the indicators.

Indicator	Status	Meaning
PWR (green)	ON	Power ON
	OFF	Power OFF
RUN (green)	ON	RUN/MONITOR mode
	OFF	PROGRAM mode or abnormal stop
ERR (red)	ON	Fatal error (operation discontinues)
	Flashing	Non-fatal error (operation continues)
	OFF	Normal
SD (yellow)	ON	CompoBus/S sending data
	OFF	CompoBus/S not sending data
RD (yellow)	ON	CompoBus/S receiving data
	OFF	CompoBus/S not receiving data
ERC (red)	ON	CompoBus/S communications error
	OFF	Other
COMM (yellow)	Flashing	Communicating with peripheral port or RS-232C port
	OFF	Other

4-5-2 Settings

The CompoBus/S System settings are described in this section.

Usable Node Number Settings

Usable node numbers are set from a Programming Device by specifying either of the following values as BCD in data memory (bits 0 to 3 of DM6603).

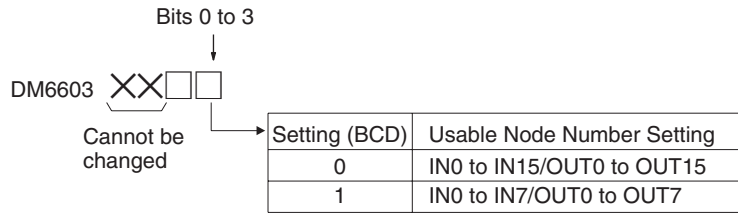

Note The setting is read when SRM1 is started. After changing the setting, be sure to restart SRM1.

Communications Mode Setting

The communications mode is set from a Programming Device by specifying either of the following values as a BCD in data memory (bits 4 to 7 of DM6603).

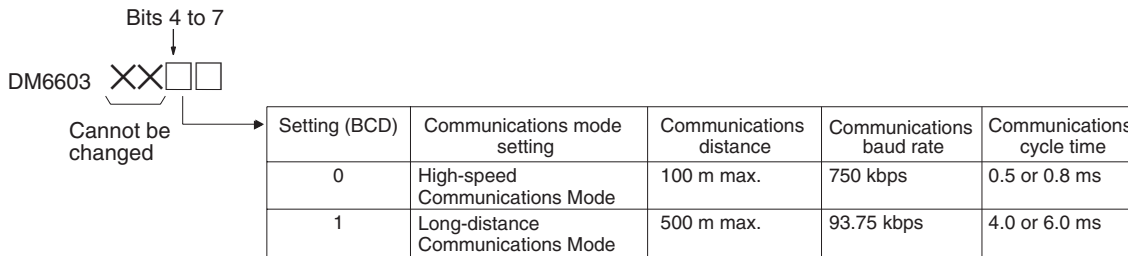

Note Long-distance Communications Mode can only be set in the SRM1-C0□-V2. Earlier models (SRM1-C0□, SRM1-C0□-V1) cannot use this mode.

4-6 CPM2C-S Series CPM2C-S□□□C (-DRT)

The CPM2C-S Series is a small PLC based on the CPM2C Series with built-in CompoBus/S Master functions. The CPM2C-S Series, like the CPM2C Series, incorporates a variety of functions, such as pulse synchronous control, input interrupt control, high-speed counters, pulse outputs, and clock functions.

Up to 32 CompoBus/S Slaves can be connected to the CPM2C-S Series to construct an I/O link system with up to 256 points (128 inputs and 128 outputs). With CompoBus/S Slaves, such as CompoBus/S Remote Terminals, Analog Terminals, Sensor Terminals, and Bit Chain Terminals connected, the CPM2C-S Series saves wiring effort and supports long-distance communications.

A model number with the suffix “-DRT” means that the model also supports DeviceNet Slave functions, thus enabling I/O linking with the DeviceNet Master.

4-6-1 Specifications and Part Names

System Configuration

The following diagram shows a system configuration of a CPM2C-S PLC with DeviceNet Slave functions.

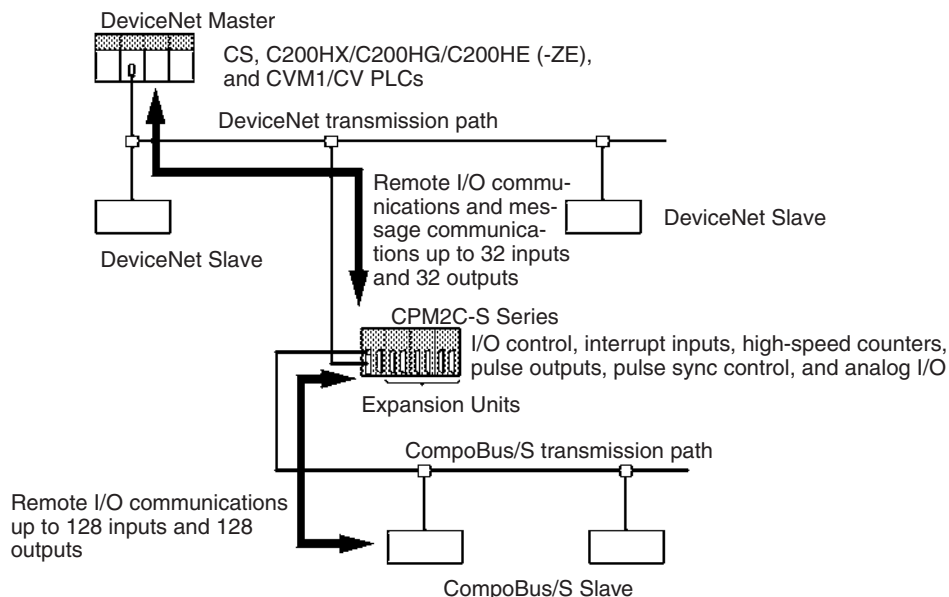

Unit Specifications

Unit	Number of inputs	Number of outputs	Model
With CompoBus/S Master functions	6 at 24 V DC	4 NPN transistors	CPM2C-S100C
		4 PNP transistors	CPM2C-S110C
With CompoBus/S Master and DeviceNet Slave functions		4 NPN transistors	CPM2C-S100C-DRT
		4 PNP transistors	CPM2C-S110C-DRT

Master Specifications

Item	Specification	
Programming method	Instruction length	
1 address/instruction	1 to 5 words/instruction	
Number of instructions	Basic instructions: 14 Special instruction: 105 (185 variations)	
Execution time	Basic instructions: 0.64 s (LD instruction) Special instructions: 7.8 s (MOV instruction)	
Program capacity	4,096 words	
Maximum I/O points	CPU: 10 points (6 inputs and 4 outputs) Expansion: 338 points (182 inputs and 156 outputs)	
Input bits	160 bits: 00000 to 00915	Bits not used as I/O bits in words can be used as work bits
Output bits	160 bits: 01000 to 01915	
CompoBus/S input bits	128 bits: 02000 to 02715	Bits not used as CompoBus/S I/O bits in words can be used as work bits
CompoBus/S output bits	128 bits: 03000 to 03715	
Work bits	672 bits: 02800 to 02915 (words 028 to 029), 03800 to 04915 (words 038 to 049), and 20000 to 22715 (words 200 to 227)	
SR bits	448 bits: 22800 to 25515 (words 228 to 255)	
TR bits	8 bits: TR0 to TR7	
HR bits	320 bits: HR 0000 to 1915 (words HR 00 to 19)	
AR bits	384 bits: AR 0000 to 2315 (words AR 00 to 23)	
LR bits	256 bits: LR 0000 to 1515 (words LR 00 to 15)	

Item		Specification
Timer/Counters		256 bits: TIM/CNT 000 to 255 1-ms timer (TMHH instruction), 10-ms timer (TIMH instruction), 100-ms timer (TIM instruction), 1-s/10-s timer (TIML instruction), Decrementing counter (CNT instruction), and reversible counter (CNTR instruction)
DM words		Read/Write: 2,048 words (DM 0000 to 2047) (DM 2000 to 2021 are the error log area.) Read-only: 456 words (DM 6144 to 6599) PLC Setup: 56 words (DM 6600 to 6655)
CompoBus/S Master function	I/O points	256 points (128 inputs and 128 outputs) or 128 points (64 inputs and 64 outputs) (Determined by the node number settings in the DM Area. The value is by default set to 256.)
	Number of points per node number	8-point mode
	Node number setting	IN0 to IN15 and OUT0 to OUT15 or IN0 to IN7 and OUT0 to OUT7 (selected with DM settings)
	I/O words	Input: 020 to 027 (CompoBus/S input bits) Output: 030 to 037 (CompoBus/S output bits)
DeviceNet Slave function		DeviceNet remote I/O link points: Up to 1,024 points (Up to 32 input words and 32 output words) Explicit message communications Read/Write any desired area from the Master
Power failure backup function		Flash memory: User program, DM (Read only), and PLC Setup Memory backup: Holds DM (Read/Write), HR, AR, and CNT contents with battery for 2 years at an ambient temperature of 25°C.
Programming Device		CQM1H-PRO01-E, CQM1-PRO01-E, or C200H-PRO27-E Programming Console WS02-CXPC1-EV2 CX-Programmer WS01-CPTB1-E SYSMAC-CPT C500-ZL3AT1-E SYSMAC Support Software

Dimensions (Same for All Units)

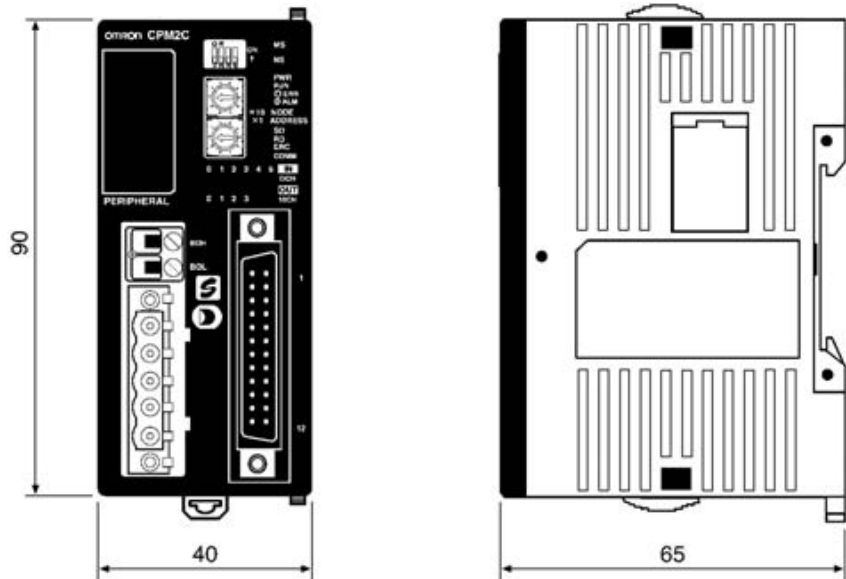

(Unit: mm)

The CPM2C-S has rotary switches for DeviceNet settings and communications connector only if the CPM2C-S model number has a suffix of “DRT.” For the dimensions of the CPM2C-S with wires connected or Expansion Units mounted, refer to the *CPM2C-S Series Operation Manual*.

Name and Function of Parts

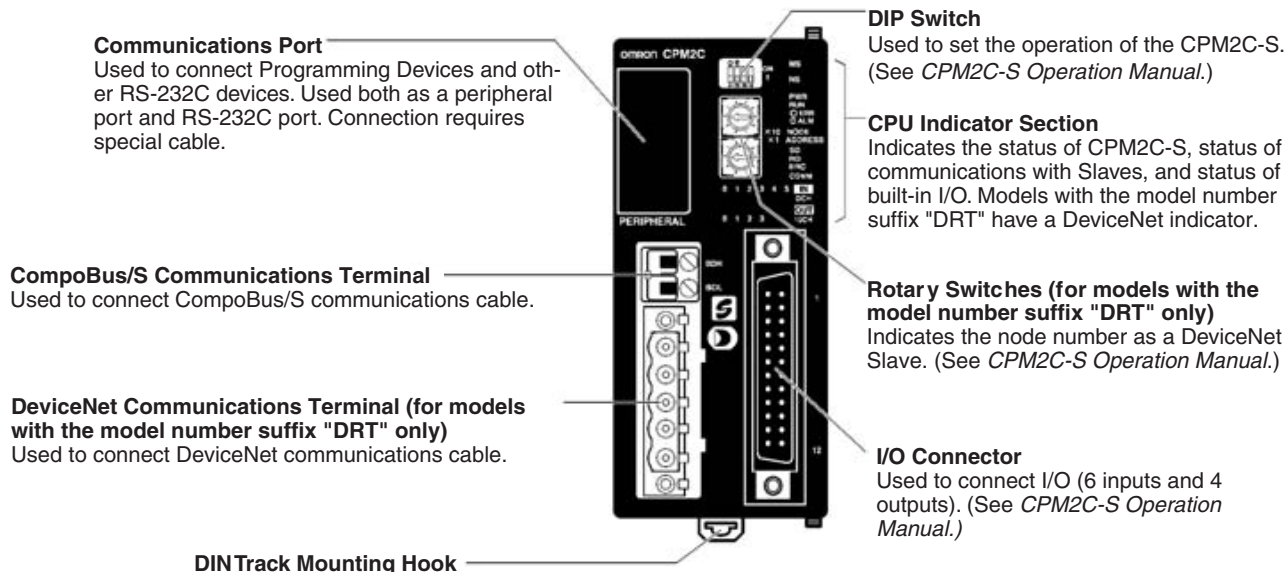

Indicators

The following table shows the meaning of the indicators.

Indicator	Name	Color	Status	Meaning
PWR	Power	Green	ON	Power ON
			OFF	Power OFF
RUN	Run	Green	ON	RUN/MONITOR mode
			OFF	PROGRAM mode or abnormal stop
ERR/ALM	Operating error	Red	ON	Fatal error (operation stops)
			Flashing	Non-fatal error (operation continues)
			OFF	Normal
SD	Sending data	Yellow	ON	CompoBus/S sending data
			OFF	CompoBus/S not sending data
RD	Receiving data	Yellow	ON	CompoBus/S receiving data
			OFF	CompoBus/S not receiving data
ERC	Communications error	Red	ON	CompoBus/S communications error
			OFF	Other
COMM	Port communications	Yellow	Flashing	Communicating with peripheral port or RS-232C port
			OFF	Other
MS (models with model number suffix "DRT" only)	Module status	Green/Red	---	Lights or flashes according to the status of the DeviceNet node. (See note.)
NS (models with model number suffix "DRT" only)	Network status	Green/Red	---	ON, flashes, or OFF according to the status of DeviceNet network. (See note.)
0 to 5	Input	Yellow	ON	Input terminals turned ON (See note.)
			OFF	Input terminals turned OFF (See note.)
0 to 3	Output	Yellow	ON	Output terminals turned ON (See note.)
			OFF	Output terminals turned OFF (See note.)

Note Refer to the *CPM2C-S Series Operation Manual* for details.

4-6-2 Settings

The CompoBus/S System settings are described in this section.

Usable Node Number Settings

Usable node numbers are set by specifying either of the following BCD values in data memory (bits 0 to 3 of DM6603).

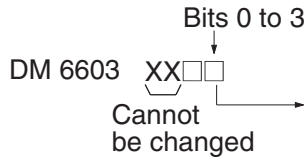

Setting (BCD)	Usable node number settings
0	IN0 to IN15/OUT0 to OUT15
1	IN0 to IN7/OUT0 to OUT7

Note The setting is read when the CPM2C-S is started. After changing the setting, be sure to restart the CPM2C-S.

Communications Mode Setting

The communications mode is set by specifying either of the following BCD values in data memory (bits 4 to 7 of DM6603).

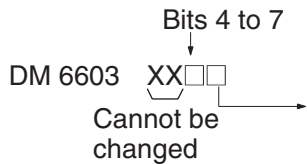

Setting (BCD)	Communications mode setting	Communications distance	Communications baud rate	Communications cycle time
0	High-speed communications mode	100 m max.	750 kbps	0.5 or 0.8 ms
1	Long-distance Communications Mode	500 m max.	93.75 kbps	4.0 or 6.0 ms

SECTION 5

Slave Specifications and Operations

This section explains the functions of each Slave, including information on specifications, switch settings, and I/O.

5-1	Remote Terminals	147
5-1-1	SRT□□-ID□□ (-1) Remote Terminals with 4, 8, or 16 Transistor Inputs	147
5-1-2	SRT□-ID16T (-1) Remote Terminals with 16 Transistor Inputs (and 3-tier Terminal Blocks)	157
5-1-3	SRT□-OD□□ (-1) Remote Terminals with 4, 8, or 16 Transistor Outputs	163
5-1-4	SRT□-OD16T (-1) Remote Terminals with 16 Transistor Outputs (and 3-tier Terminal Blocks)	173
5-1-5	SRT□-MD16T (-1) Remote Terminals with 8 Input and 8 Output Transistors (3-tier Terminal Block)	179
5-1-6	SRT□-RO□□□ Remote Terminals with Relay/Power MOS FETs	185
5-2	Connector Terminals	194
5-2-1	SRT2-VID□□□□ (-1) Connector Terminals with 8 Input or 16 Output Transistors	194
5-2-2	SRT2-VOD□□□□ (-1) Connector Terminals with 8 or 16 Transistor Outputs	213
5-2-3	SRT2-ID32ML (-1) Connector Terminals with 32 Transistor Inputs	225
5-2-4	SRT2-OD32ML (-1) Connector Terminals with 32 Transistor Outputs	236
5-2-5	SRT2-MD32ML (-1) Connector Terminals with 16 Transistor Inputs and 16 Transistor Outputs	246
5-2-6	Wiring and Assembly of Communications Connector and MIL Connector for Connector Terminals	256
5-3	Remote I/O Modules	260
5-3-1	SRT□-□D16P Remote I/O Modules	260
5-4	Water-resistant Terminals	268
5-4-1	SRT2-ID□□CL (-1) Water-resistant Terminals with 4 or 8 Transistor Inputs	268
5-4-2	SRT2-OD□□CL (-1) Water-resistant Terminals with 4 or 8 Transistor Outputs	277
5-4-3	Shielded Connector Wiring and Assembly	284
5-5	Sensor Terminals	287
5-5-1	SRT□-□D08S Sensor Terminals with 8 Transistor Inputs or 4 Transistor Inputs and 4 Transistor Outputs	287
5-5-2	SRT□-OD08S Sensor Terminal with 8 Transistor Outputs	295
5-6	Fiber Amplifier Communications Units	301
5-6-1	E3X-SRT21 Fiber Amplifier Communications Unit	301
5-7	Analog Input Terminals	308
5-7-1	SRT2-AD04 Analog Input Terminal	308
5-8	Analog Output Terminals	318
5-8-1	SRT2-DA02 Analog Output Terminal	318

5-9	I/O Link Units for CPM1A and CPM2A.....	327
5-9-1	CPM1A-SRT21 I/O Link Unit for CPM1A and CPM2A.....	327
5-10	I/O Link Units for CPM2C	331
5-10-1	CPM2C-SRT21 I/O Link Unit for CPM2C.....	331
5-11	Sensor Amplifier Terminals.....	335
5-11-1	SRT1-T□D04S Sensor Amplifier Terminals	335
5-11-2	Sensor Amplifier Terminals	343
5-12	Application Precautions.....	350
5-12-1	Two-wire DC Sensor Connections	350
5-12-2	Sensor Inrush Current	351

5-1 Remote Terminals

5-1-1 SRT□□-ID□□ (-1) Remote Terminals with 4, 8, or 16 Transistor Inputs

Specifications

The following tables show the ratings and input specifications for the SRT□-ID□□ (-1) Remote Terminals.

Ratings

Item	Specification
Models	SRT1-ID04 SRT1-ID08 SRT1-ID16 SRT1-ID04-1 SRT1-ID08-1 SRT1-ID16-1 SRT2-ID04 SRT2-ID08 SRT2-ID16 SRT2-ID04-1 SRT2-ID08-1 SRT2-ID16-1
Input points	SRT□-ID04: 4 points (NPN) SRT□-ID08: 8 points (NPN) SRT□-ID16: 16 points (NPN) SRT□-ID04-1: 4 points (PNP) SRT□-ID08-1: 8 points (PNP) SRT□-ID16-1: 16 points (PNP)
Communications mode	SRT1-ID□□ (-1): High-speed Communications Mode SRT2-ID□□ (-1): High-speed Communications Mode or Long-distance Communications Mode
Power supply type	Multiple power supplies
Communications power supply voltage	14 to 26.4 V DC (Power can be supplied from the Special Flat Cable.)
I/O power supply voltage	20.4 to 26.4 V DC (24 V DC $+10\%$ / -15%)
I/O power supply current	1 A max.
Current consumption (See note.)	Communications power: 50 mA max. at 24 V DC
Noise immunity	± 1.5 kVp-p with a pulse width of 0.1 to 1 μ s and a rise time of 1 ns (via impulse noise simulator)
Vibration resistance	10 to 55 Hz, 1.0 mm double-amplitude
Shock resistance	200 m/s ²
Dielectric strength	500 V AC (between insulated circuits)
Ambient temperature	Operating: 0 to 55°C (with no icing or condensation) Storage: -20 to 65°C (with no icing or condensation)
Ambient humidity	Operating: 35% to 85% (with no condensation) Storage: 25% to 85% (with no condensation)
Operating environment	No corrosive gases
Mounting method	M4 screws or 35-mm DIN track mounting
Mounting strength	Pulling: 50 N Tightening: 1.5 N • m
Terminal strength	Pulling: 50 N Tightening: 0.6 to 1.18 N • m

Item	Specification
Node number settings	The node number is set on a DIP switch. (Set the node number before turning on the Slave.)
Weight	SRT□-ID04: 80 g max. SRT□-ID08: 80 g max. SRT□-ID16: 110 g max. SRT□-ID04-1: 80 g max. SRT□-ID08-1: 80 g max. SRT□-ID16-1: 110 g max.

Note The current consumption is the value with all 4 and 8 and 16 points turned ON excluding the current consumption of the external sensor connected to the input Remote Terminal and the current consumption of the load connected to the output Remote Terminal.

Input Specifications

Item	Specification
Input current	6 mA max./point at 24 V DC
ON delay time	1.5 ms max.
OFF delay time	1.5 ms max.
ON voltage	SRT□-ID□□: 15 V DC min. (between each input terminal and V) SRT□-ID□□-1: 15 V DC min. (between each input terminal and G)
OFF voltage	SRT□-ID□□: 5 V DC min. (between each input terminal and V) SRT□-ID□□-1: 5 V DC min. (between each input terminal and G)
OFF current	1 mA max.
Insulation method	Photocoupler
Input indicators	LED (yellow)

Slave Components

The following diagram shows the main components of the SRT2-ID08 Transistor Remote Terminal. The functions of these components are described below.

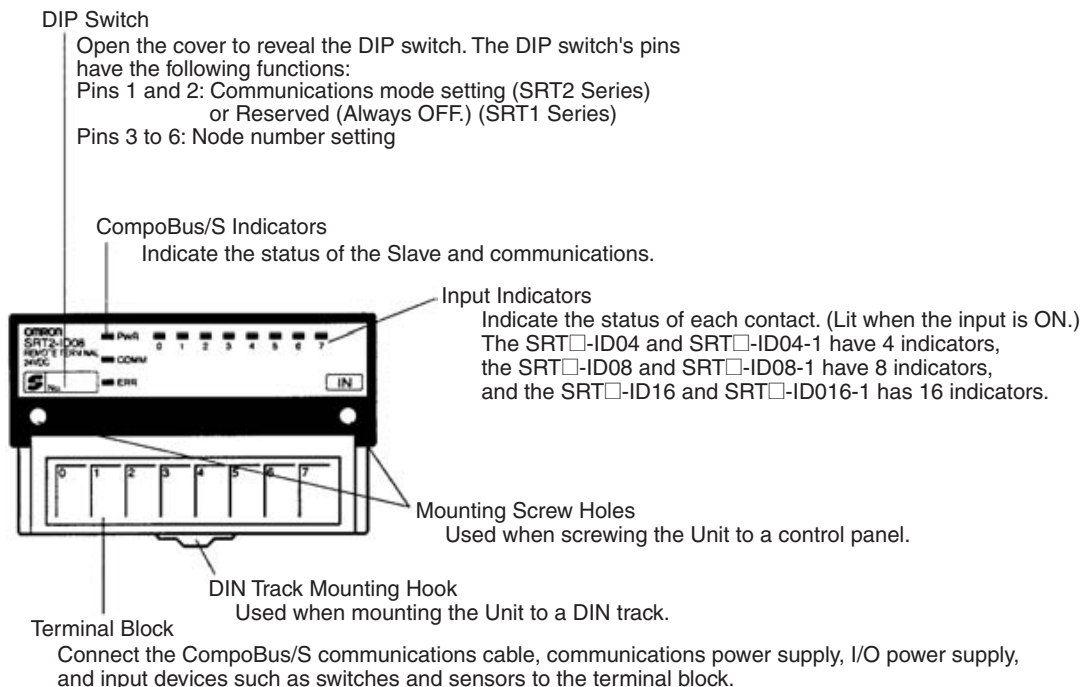

Indicators

The following table shows the meaning of the indicators.

Indicator	Status	Meaning
PWR (green)	ON	The communications power supply is ON.
	OFF	The communications power supply is OFF.
COMM (yellow)	ON	Normal communications
	OFF	A communications error has occurred or the Unit is in standby status.
ERR (red)	ON	A communications error has occurred.
	OFF	Normal communications or the Unit is in standby status.
0 to 3 (4 inputs)	ON	The corresponding input is ON.
0 to 7 (8 inputs)	OFF	The corresponding input is OFF or the Unit is in standby status.
0 to 15 (16 inputs) (yellow)		

DIP Switch

The DIP switch is located on the left side of the Transistor Remote Terminal, under the cover. Always turn OFF the Slave before changing the node number setting.

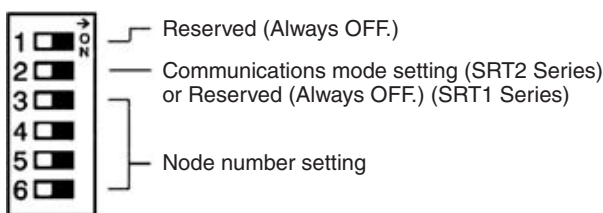

- Note**
1. Always turn OFF the Slave before changing DIP switch settings.
 2. In the SRT1 Series, pin 2 must always be left OFF. Otherwise, the Unit may not function correctly.

Communications Mode Settings (SRT2 Series Only)

The following communications modes are set with pin 2.

Pin 2	Communications mode	Communications distance	Communications baud rate	Communications cycle time
OFF	High-speed Communications Mode	100 m max.	750 kbps	0.5 or 0.8 ms
ON	Long-distance Communications Mode	500 m max.	93.75 kbps	4.0 or 6.0 ms

The communications mode settings using pin 2 only apply to SRT2-series Slaves and cannot be used with the SRT1-series Slaves, which operate in High-speed Communications Mode at all times.

- Note** Make sure that the communications mode of the Slave is the same as that of the Master Unit. If the communications modes are not the same, normal communications with the Master Unit will not be possible. The operating status of the Slave can be verified with LED indicators. Refer to 6-5-1 Indicators.

Node Number Settings

Set the node number with pins 3 through 6, as shown in the following table.

Node number	Pin 3 (8)	Pin 4 (4)	Pin 5 (2)	Pin 6 (1)
0	OFF	OFF	OFF	OFF
1	OFF	OFF	OFF	ON
2	OFF	OFF	ON	OFF
3	OFF	OFF	ON	ON
4	OFF	ON	OFF	OFF
5	OFF	ON	OFF	ON
6	OFF	ON	ON	OFF
7	OFF	ON	ON	ON
8	ON	OFF	OFF	OFF
9	ON	OFF	OFF	ON
10	ON	OFF	ON	OFF
11	ON	OFF	ON	ON
12	ON	ON	OFF	OFF
13	ON	ON	OFF	ON
14	ON	ON	ON	OFF
15	ON	ON	ON	ON

Note The actual node number setting range depends on the type of PLC in which the Master is mounted as well as the Master's settings. Refer to *2-1 Communications Specifications* for details.

Internal Circuits

The following diagram shows the internal circuits for the SRT□-ID04.

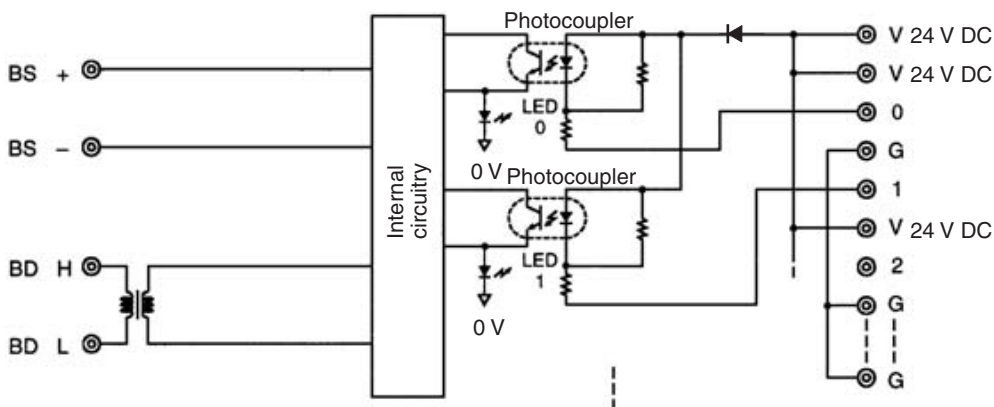

The following diagram shows the internal circuits for the SRT□-ID04-1.

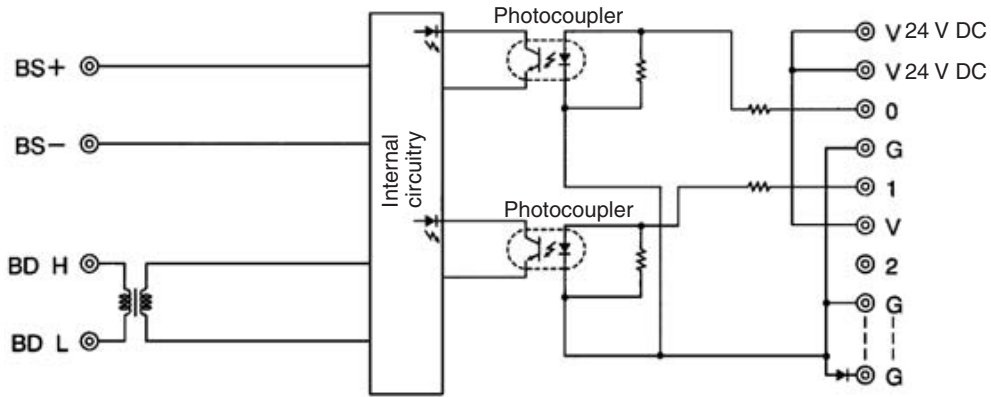

The following diagram shows the internal circuits for the SRT□-ID08.

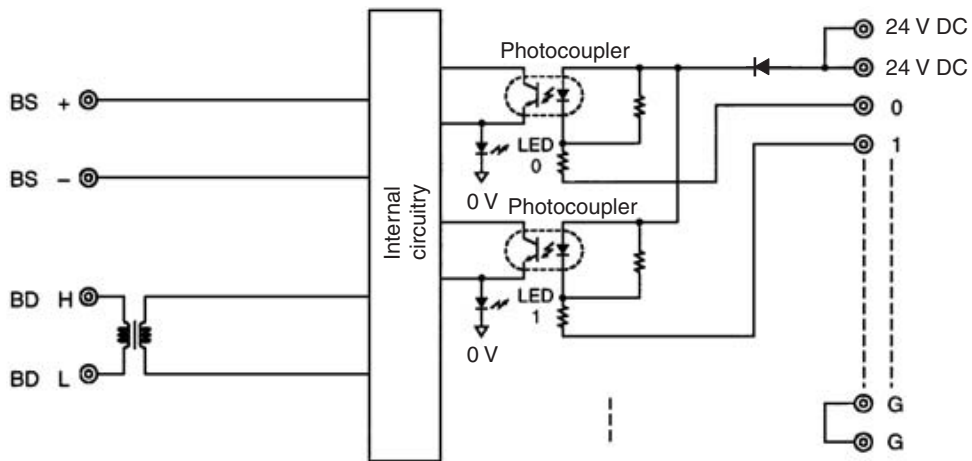

The following diagram shows the internal circuits for the SRT□-ID08-1.

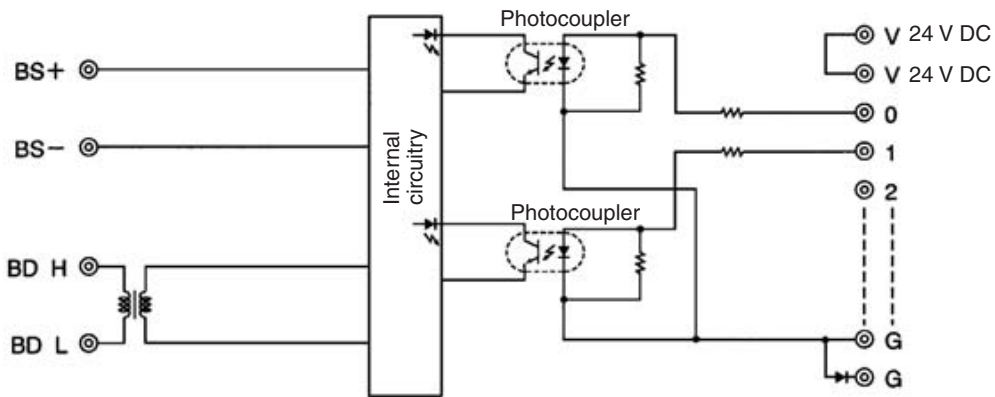

The following diagram shows the internal circuits for the SRT□-ID16.

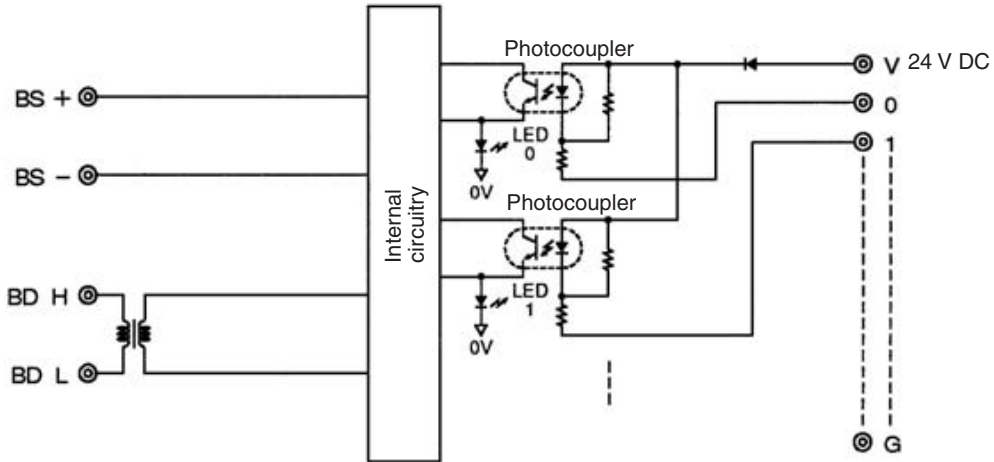

The following diagram shows the internal circuits for the SRT□-ID16-1.

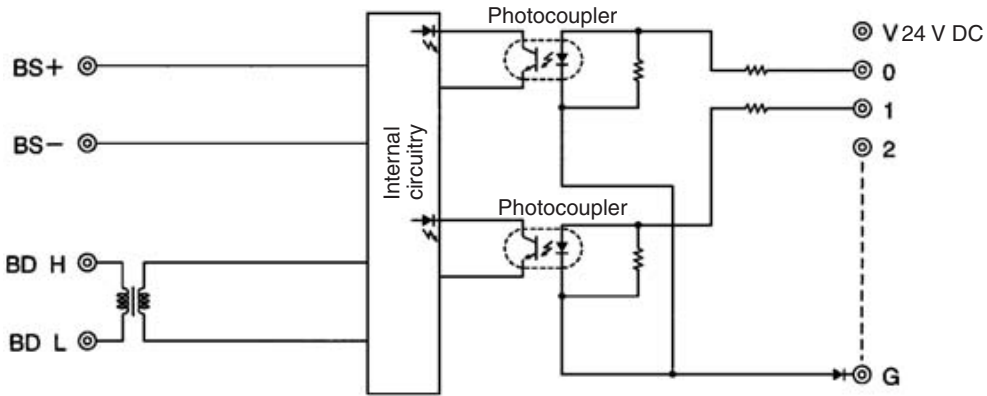

Terminal Arrangement and Wiring

Install the following M3 crimp terminals on the signal wires and connect to the terminal block.



Tighten the terminal block screws to the specified tightening torque of 0.5 N·m.

The following diagram shows the terminal arrangement and wiring for the SRT□-ID04.

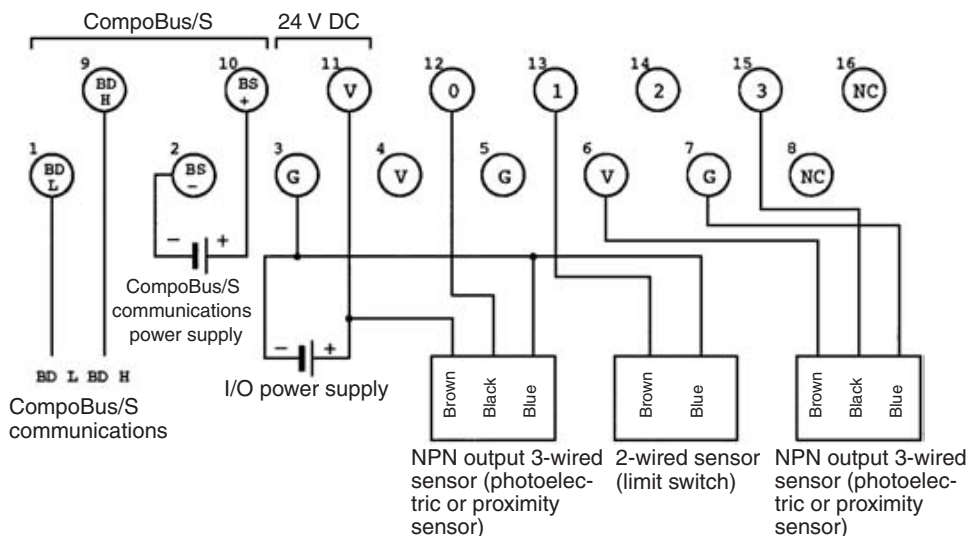

Note The V terminals (terminal numbers 4, 6, and 11) are all connected internally, as are the G terminals (terminal numbers 3, 5, and 7). When I/O power is supplied to terminals 11 and 3, power can be supplied to sensors from terminals 4 and 5 as well as 6 and 7. When the power supply exceeds 1.0 A, provide an external power supply to the I/O power supply instead of providing the supply from the terminals.

The following diagram shows the terminal arrangement and wiring for the SRT□-ID04-1.

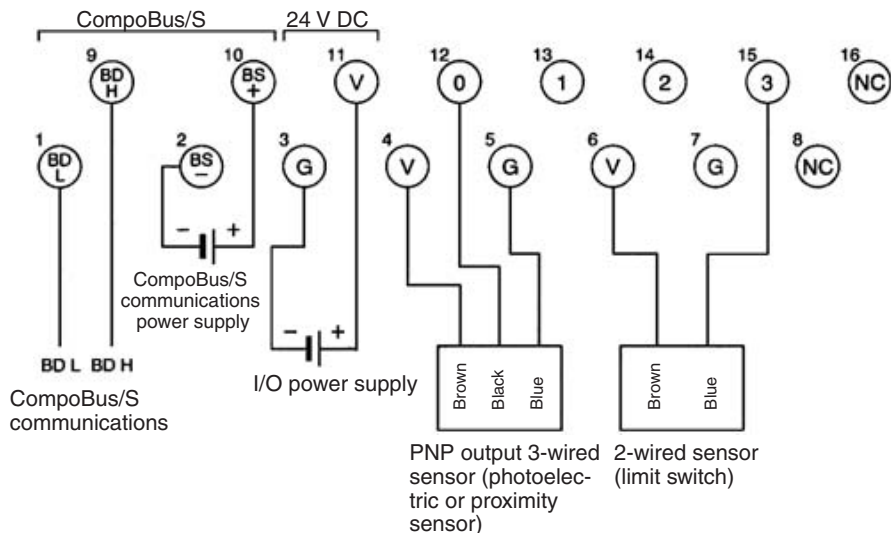

Note The V terminals (terminal numbers 4, 6, and 11) are all connected internally, as are the G terminals (terminal numbers 3, 5, and 7). When I/O power is supplied to terminals 11 and 3, power can be supplied to sensors from terminals 4 and 5 as well as 6 and 7. When the power supply exceeds 1.0 A, provide an external power supply to the I/O power supply instead of providing the supply from the terminals.

The following diagram shows the terminal arrangement and wiring for the SRT□-ID08.

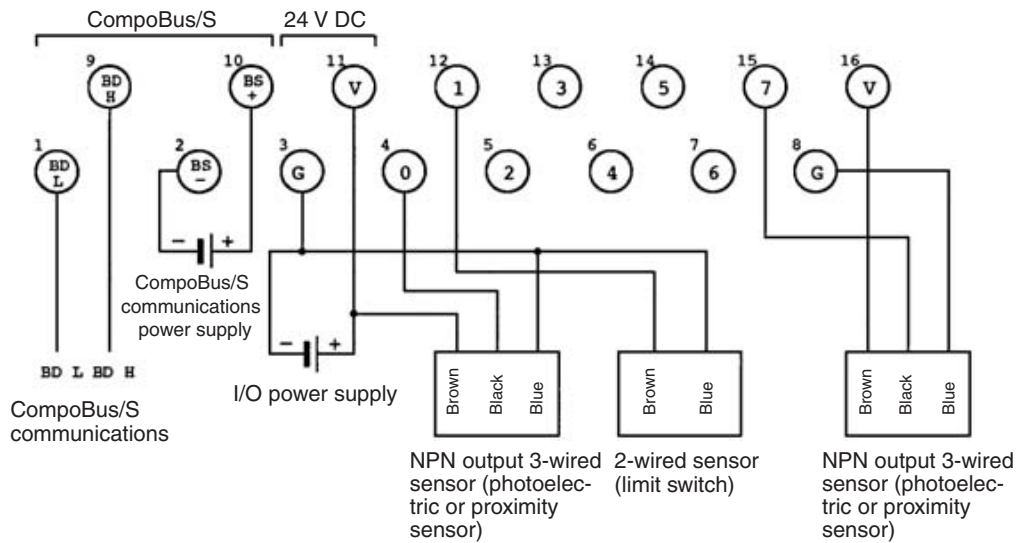

Note The V terminals (terminal numbers 11 and 16) are all connected internally, as are the G terminals (terminal numbers 3 and 8). When I/O power is supplied to terminals 11 and 3, power can be supplied to sensors from terminals 16 and 8.

When the power supply exceeds 1.0 A, provide an external power supply to the I/O power supply instead of providing the supply from the terminals.

The following diagram shows the terminal arrangement and wiring for the SRT□-ID08-1.

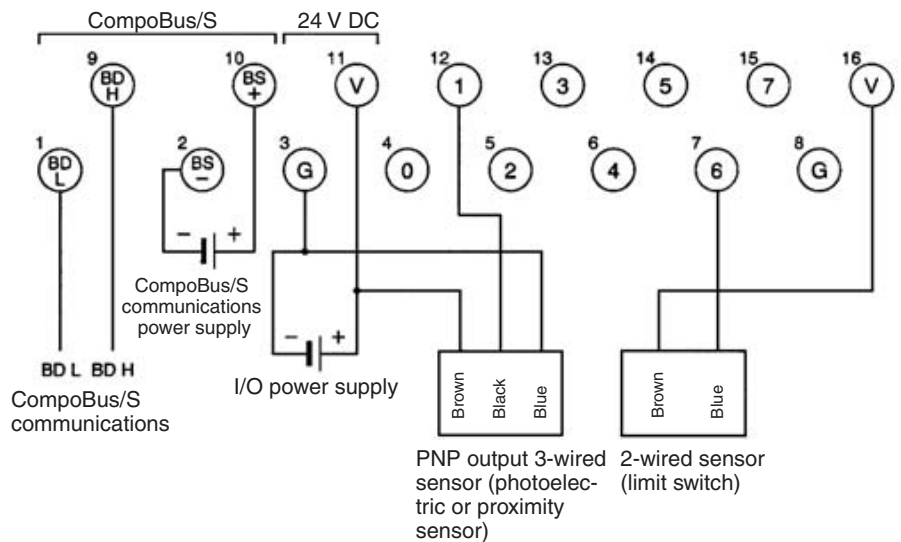

Note The V terminals (terminal numbers 11 and 16) are all connected internally, as are the G terminals (terminal numbers 3 and 8). When I/O power is supplied to terminals 11 and 3, power can be supplied to sensors from terminals 16 and 8.

When the power supply exceeds 1.0 A, provide an external power supply to the I/O power supply instead of providing the supply from the terminals.

The following diagram shows the terminal arrangement and wiring for the SRT□-ID16.

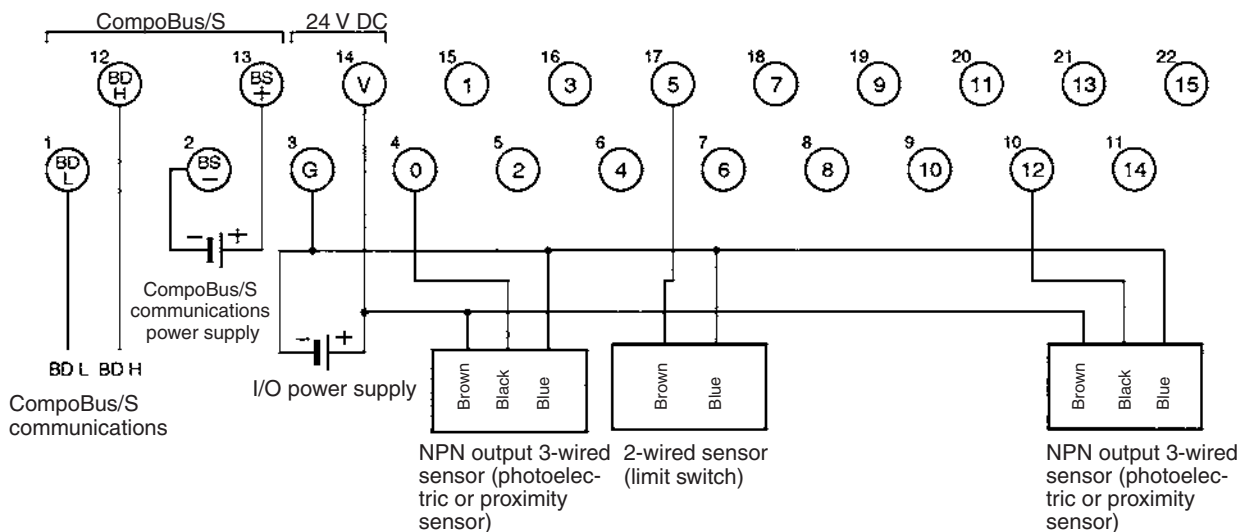

The following diagram shows the terminal arrangement and wiring for the SRT□-ID16-1.

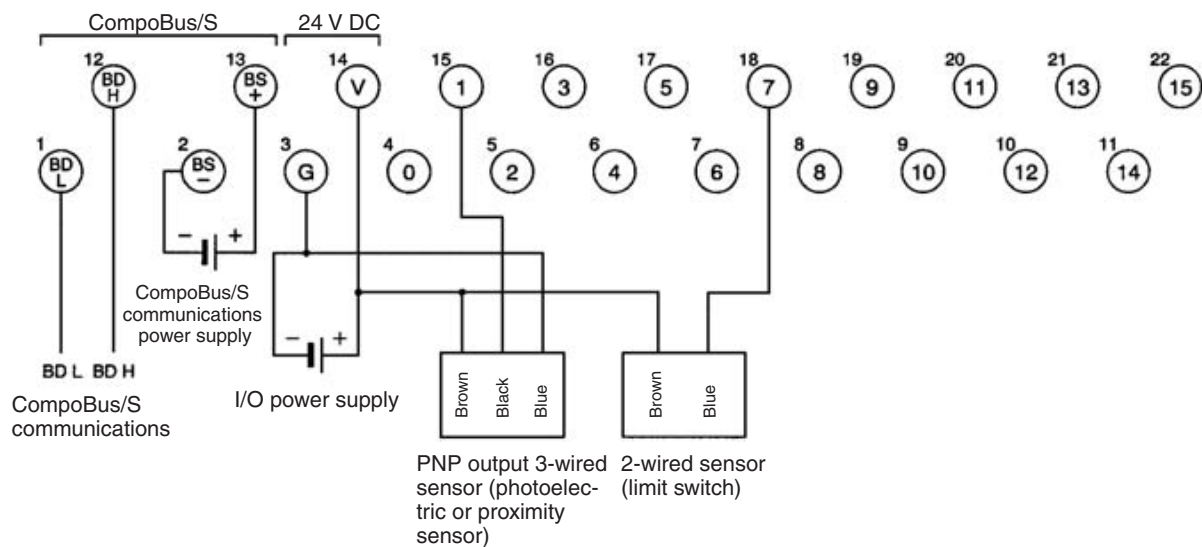

**SRT□-ID04/ID04-1/ID08/
ID08-1 Dimensions**

The following diagram shows the dimensions for the SRT□-ID04/ID04-1/ID08/
ID08-1. All dimensions are in mm.

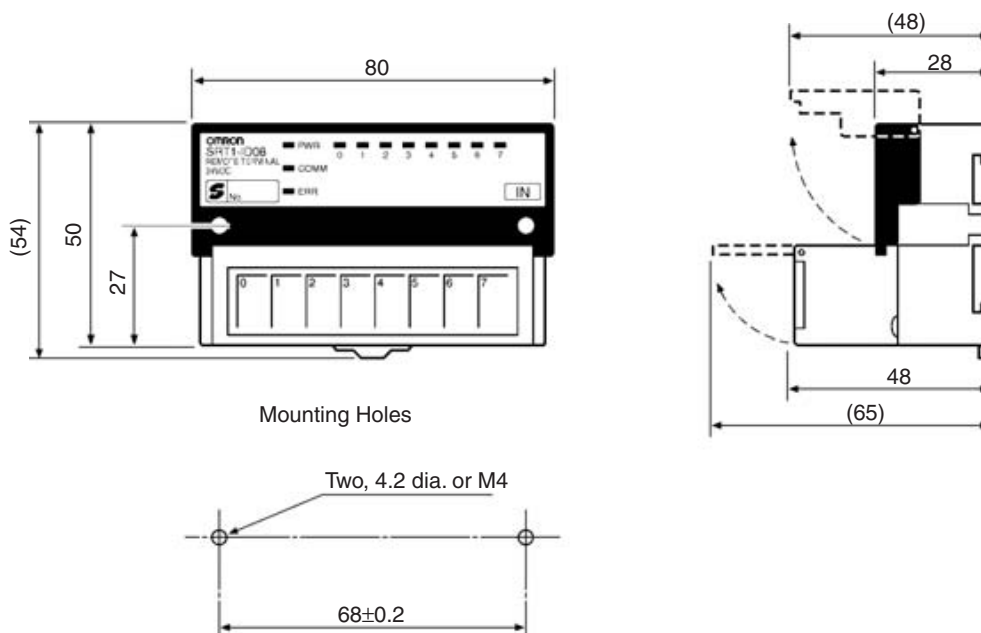

**SRT□-ID16/ID16-1
Dimensions**

The following diagram shows the dimensions for the SRT□-ID16/ID16-1. All dimensions are in mm.

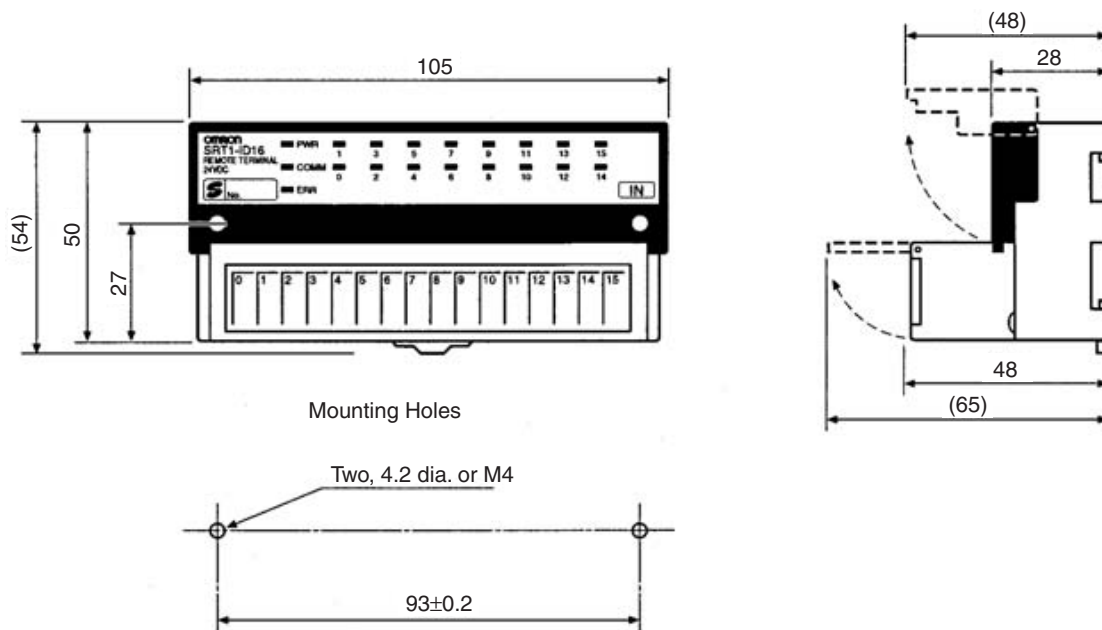

5-1-2 SRT□-ID16T (-1) Remote Terminals with 16 Transistor Inputs (and 3-tier Terminal Blocks)

Specifications

The following tables show the ratings and input specifications for the SRT□-ID16T (-1) Remote Terminal.

Ratings

Item	Specification
Models	SRT1-ID16T SRT1-ID16T-1 SRT2-ID16T SRT2-ID16T-1
Input points	SRT□-ID16T: 16 points (NPN) SRT□-ID16T-1: 16 points (PNP)
Communications mode	SRT1-ID16T (-1): High-speed Communications Mode SRT2-ID16T (-1): High-speed Communications Mode and Long-distance Communications Mode
Terminal	3-tier terminal block (with common I/O terminal for each input point)
Power supply type	Multiple power supplies
Communications power supply voltage	14 to 26.4 V DC (Power can be supplied from the communications cable)
I/O power supply voltage	20.4 to 26.4 V DC (24 V DC $+10\%$ / -15%)
Current consumption (See note.)	Communications power: 50 mA max. at 24 V DC
Noise immunity	± 1.5 kVp-p with a pulse width of 0.1 to 1 μ s and a rise time of 1 ns (via impulse noise simulator)
Vibration resistance	10 to 150 Hz, 1.0-mm double amplitude or 70 m/s ²
Shock resistance	Malfunction: 200 m/s ²
Dielectric strength	500 V AC (between insulated circuits) 1,000 V AC for 1 minute (1-mA sensing current, between charged and uncharged sections)
Ambient temperature	Operating: -10 to 55°C (with no icing or condensation) Storage: -25 to 65°C (with no icing or condensation)
Ambient humidity	Operating: 25% to 85% (with no condensation) Storage: 25% to 85% (with no condensation)
Operating environment	No corrosive gases
Mounting method	M4 screws or 35-mm DIN track mounting
Mounting strength	100 N in each direction
Terminal strength	Pulling: 100 N Tightening: 0.3 to 0.5 N • m
Node number settings	The node number is set with a rotary switch. (Set before turning ON the Slave.)
Weight	300 g max.

Note The current consumption is the value with all 16 points turned ON excluding the current consumption of the external sensor connected to the input Remote Terminal and the current consumption of the load connected to the output Remote Terminal.

Input Specifications

Item	Specification
Input current	6 mA max./point at 24 V DC 3 mA min./point at 17 V DC
ON delay time	1.5 ms max.
OFF delay time	1.5 ms max.
ON voltage	SRT□-ID16T: 15 V DC min. (between each input terminal and V) SRT□-ID16T-1: 15 V DC min. (between each input terminal and G)
OFF voltage	SRT□-ID16T: 5 V DC max. (between each input terminal and V) SRT□-ID16T-1: 5 V DC max. (between each input terminal and G)
OFF current	1 mA max. at 24 V DC
Insulation method	Photocoupler
Input indicators	LED (yellow)

Slave Components

The following diagram shows the main components of the SRT2-ID16T Transistor Remote Terminal. The functions of these components are described below.

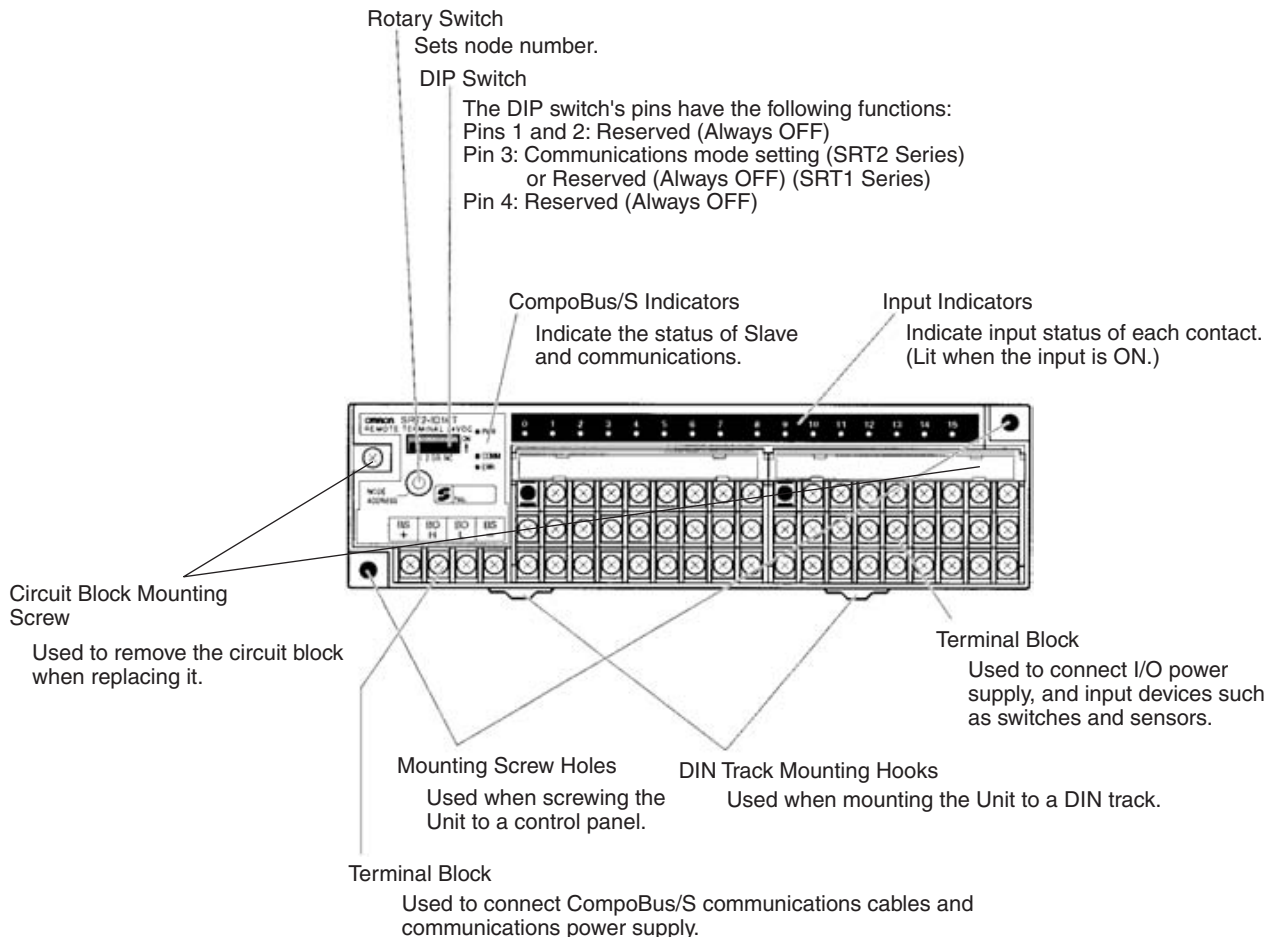

Indicators

The following table shows the meaning of the indicators.

Indicator	Status	Meaning
PWR (green)	ON	The communications power supply is ON.
	OFF	The communications power supply is OFF.

Indicator	Status	Meaning
COMM (yellow)	ON	Normal communications
	OFF	A communications error has occurred or the Unit is in standby status.
ERR (red)	ON	A communications error has occurred.
	OFF	Normal communications or the Unit is in standby status.
0 to 15 (yellow)	ON	The corresponding input is ON.
	OFF	The corresponding input is OFF or the Unit is in standby status.

Switch Settings

Rotary and DIP switches are used to enter settings.

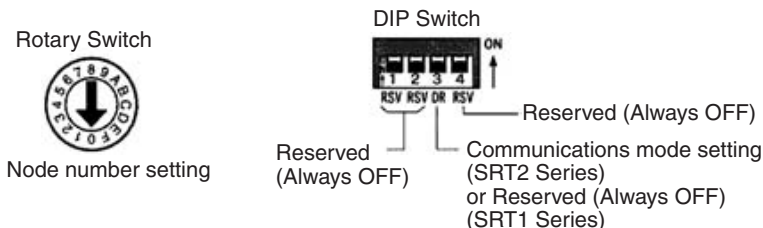

- Note**
1. Always turn OFF the Slave before changing DIP switch settings.
 2. In the SRT1 Series, pin 3 must always be left OFF. Otherwise, the Unit may not function correctly.
 3. All pins marked “RSV” (reserved) must be left OFF. If any of them is ON, the Unit may not function correctly.

Node Number Settings

The rotary switch specifies node numbers as hexadecimal numbers, as shown below.

Node number	Setting (Hexadecimal)	Node number	Setting (Hexadecimal)
0	0	8	8
1	1	9	9
2	2	10	A
3	3	11	B
4	4	12	C
5	5	13	D
6	6	14	E
7	7	15	F

- Note**
1. Node numbers of 16-point Slaves are always treated as even numbers. Even if an odd number is specified, the actual node number setting becomes the even number immediately preceding it.
 2. The actual node number setting range depends on the type of PLC in which the Master is mounted as well as the Master’s settings. Refer to 2-1 Communications Specifications for details.

Communications Mode Settings (SRT2 Series Only)

The communications mode is set with pin 3, as shown below.

Pin 3	Communications mode	Communications distance	Communications baud rate	Communications cycle time
OFF	High-speed Communications Mode	100 m max.	750 kbps	0.5 or 0.8 ms
ON	Long-distance Communications Mode	500 m max.	93.75 kbps	4.0 or 6.0 ms

The communications mode settings using pin 3 only apply to the SRT2-series Slaves and cannot be used with the SRT1-series Slaves, which operate in High-speed Communications Mode at all times.

Internal Circuits

The following diagram shows the internal circuits for the SRT□-ID16T.

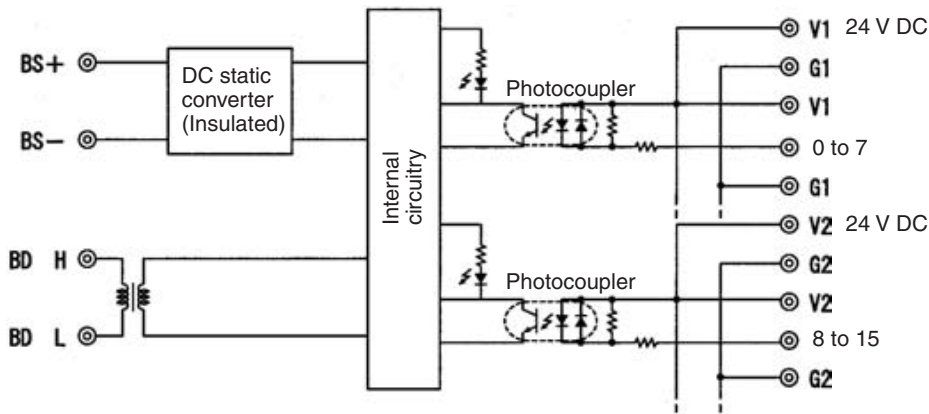

The following diagram shows the internal circuits for the SRT□-ID16T-1.

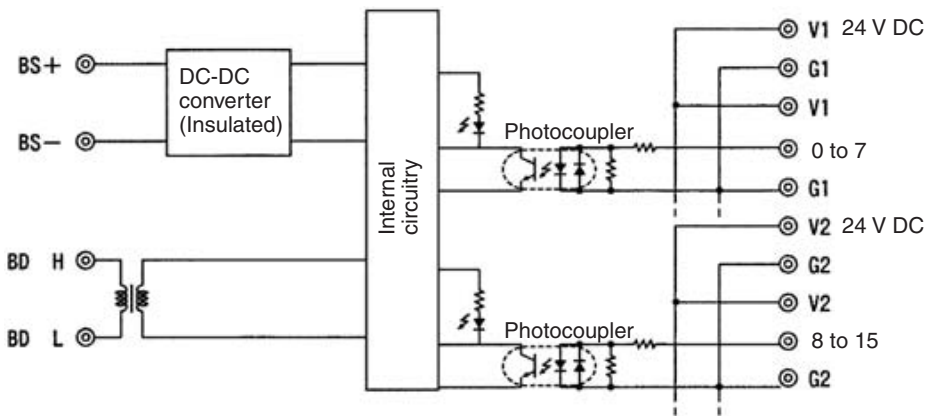

Terminal Arrangement and Wiring

Install the following M3 crimp terminals on the signal wires and connect to the terminal block.



Note Tighten the terminal block screws to the specified tightening torque of 0.5 N·m.

The following diagram shows the terminal arrangement and wiring for the SRT□-ID16T.

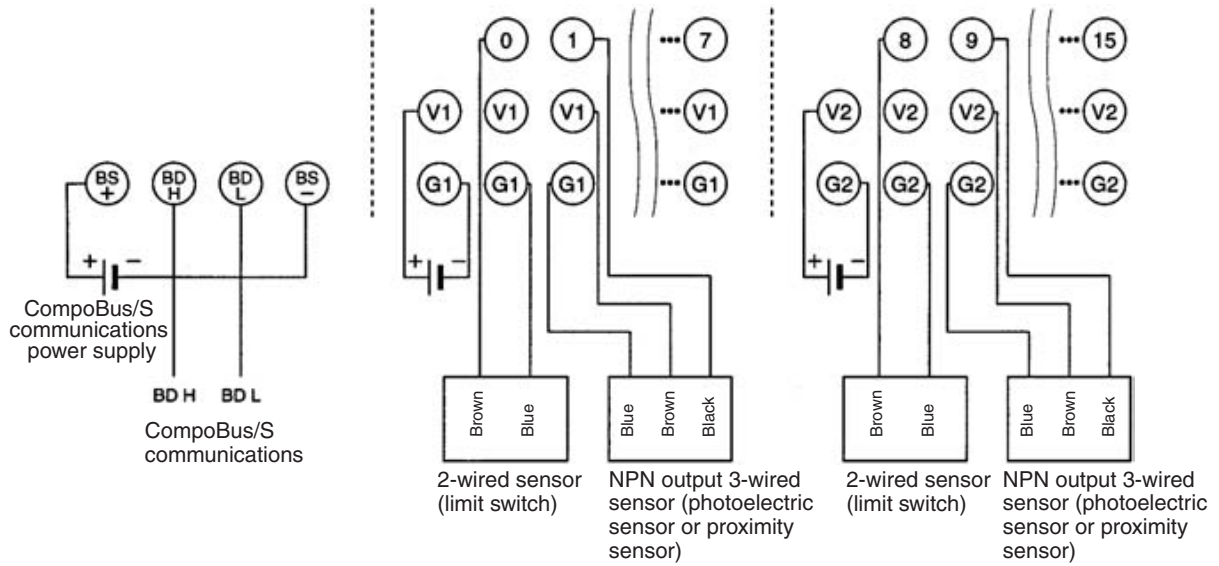

The following diagram shows the terminal arrangement and wiring for the SRT□-ID16T-1.

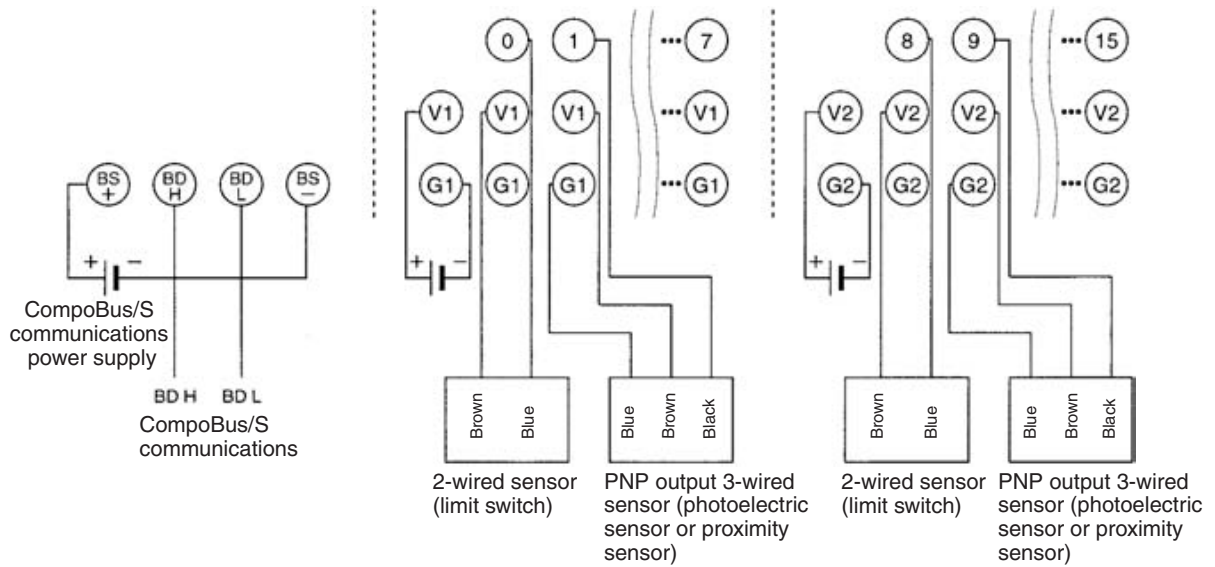

Note The V terminals V1 and V2 are not connected internally, and neither are the G terminals G1 and G2 (I/O power supply). Care must be taken when connecting them.

SRT□-ID16T/ID16T-1
Dimensions

The following diagram shows the dimensions for the SRT□-ID16T/ID16T-1. All dimensions are in mm.

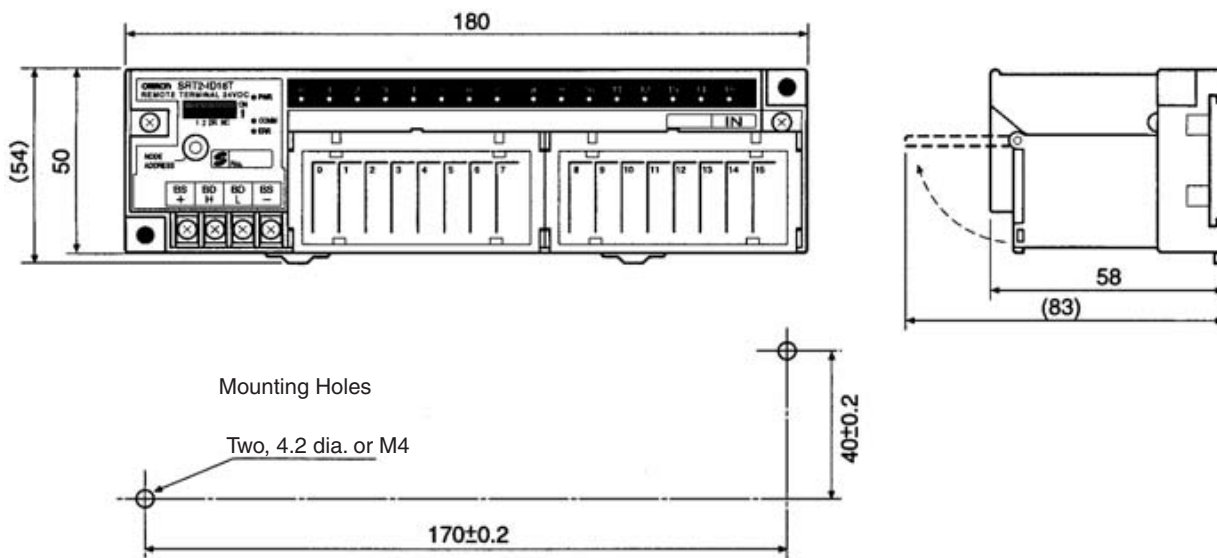

Note The circuit block can be removed by loosening the circuit block mounting screw. Before removing the circuit block for replacement, check that all power supplies, including I/O power supply, to the Unit are turned OFF.

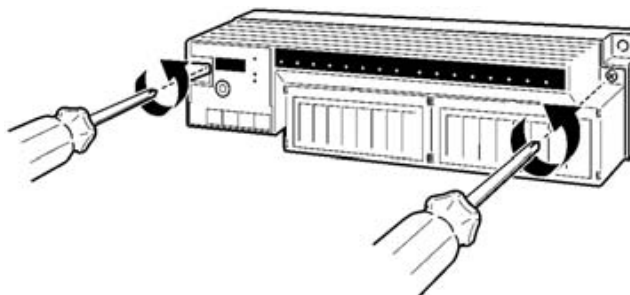

5-1-3 SRT□-OD□□ (-1) Remote Terminals with 4, 8, or 16 Transistor Outputs

Specifications

The following tables show the ratings and output specifications for the SRT□-OD□□ (-1).

Ratings

Item	Specification
Models	SRT1-OD04 SRT1-OD08 SRT1-OD16 SRT1-OD04-1 SRT1-OD08-1 SRT1-OD16-1 SRT2-OD04 SRT2-OD08 SRT2-OD16 SRT2-OD04-1 SRT2-OD08-1 SRT2-OD16-1
Output points	SRT□-OD04: 4 points (NPN) SRT□-OD08: 8 points (NPN) SRT□-OD16: 16 points (NPN) SRT□-OD04-1: 4 points (PNP) SRT□-OD08-1: 8 points (PNP) SRT□-OD16-1: 16 points (PNP)
Communications mode	SRT1-OD□□ (-1): High-speed Communications Mode SRT2-OD□□ (-1): High-speed Communications Mode and Long-distance Communications Mode
Power supply type	Multiple power supplies
Communications power supply voltage	14 to 26.4 V DC (Power can be supplied from the communications cable)
I/O power supply voltage	20.4 to 26.4 V DC (24 V DC $+10\%$ / -15%)
I/O power supply current	SRT□-OD04 and SRT□-OD04-1: 1 A max. SRT□-OD08 and SRT□-OD08-1: 1 A max.
Current consumption (See note.)	Communications power: 50 mA max. at 24 V DC
Noise immunity	± 1.5 kVp-p with a pulse width of 0.1 to 1 μ s and a rise time of 1 ns (via impulse noise simulator)
Vibration resistance	10 to 55 Hz, 1.0-mm double amplitude
Shock resistance	Malfunction: 200 m/s ²
Dielectric strength	500 V AC (between insulated circuits)
Ambient temperature	Operating: 0 to 55°C (with no icing or condensation) Storage: -20 to 65°C (with no icing or condensation)
Ambient humidity	Operating: 35% to 85% (with no condensation) Storage: 20% to 85% (with no condensation)
Operating environment	No corrosive gases
Mounting method	M4 screws or 35-mm DIN track mounting
Mounting strength	Pulling: 50 N Tightening: 1.5 N • m
Terminal strength	Pulling: 50 N Tightening: 0.6 to 1.18 N • m

Item	Specification
Node number settings	The node number is set on a DIP switch. (Set the node number before turning ON the Slave.)
Weight	SRT□-OD04: 80 g max. SRT□-OD08: 80 g max. SRT□-OD16: 110 g max. SRT□-OD04-1: 80 g max. SRT□-OD08-1: 80 g max. SRT□-OD16-1: 110 g max.

Note The current consumption is the value with all 4 and 8 and 16 points turned ON excluding the current consumption of the external sensor connected to the input Remote Terminal and the current consumption of the load connected to the output Remote Terminal.

Output Specifications

Item	Specification
Rated output current	0.3 A/point
Residual voltage	0.6 V max. SRT□-OD□□: Between each output terminal and G SRT□-OD□□-1: Between each output terminal and V
Leakage current	0.1 mA max.
ON delay time	0.5 ms max.
OFF delay time	1.5 ms max.
Insulation method	Photocoupler
Output indicators	LED (yellow)

Slave Components

The following diagram shows the main components of the SRT2-OD08 Transistor Remote Terminal. The functions of these components are described below.

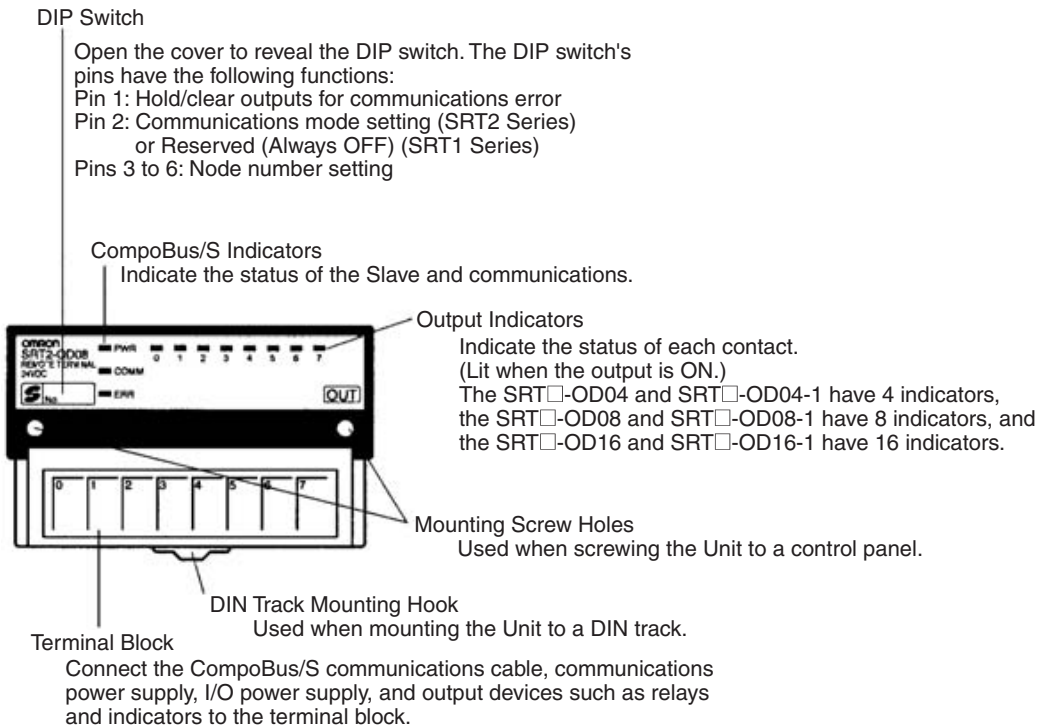

Indicators

The following table shows the meaning of the indicators.

Indicator	Status	Meaning
PWR (green)	ON	The communications power supply is ON.
	OFF	The communications power supply is OFF.
COMM (yellow)	ON	Normal communications
	OFF	A communications error has occurred or the Unit is in standby status.
ERR (red)	ON	A communications error has occurred.
	OFF	Normal communications or the Unit is in standby status.
0 to 3 (4 outputs) 0 to 7 (8 outputs) 0 to 15 (16 outputs) (yellow)	ON	The corresponding output is ON.
	OFF	The corresponding output is OFF or the Unit is in standby status.

DIP Switch

The DIP switch is located on the left side of the Transistor Remote Terminal, under the cover. Always turn OFF the Slave before changing DIP switch settings.

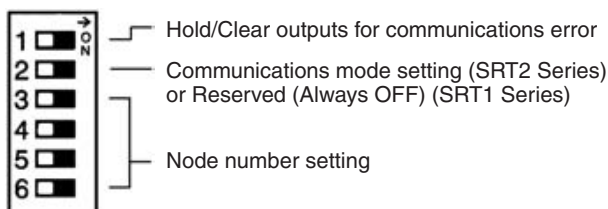

- Note**
1. Always turn OFF the Slave before changing DIP switch settings.
 2. In the SRT1 Series, pin 2 must always be left OFF. Otherwise, the Unit may not function correctly.

Hold/Clear Outputs for Communications Error

Pin 1 is used to set the output data status when a communications error occurs, as shown in the following table.

Pin 1 (HOLD)	Output setting
OFF	Clear output status.
ON	Maintain output status.

Communications Mode Settings (SRT2 Series Only)

The following communications modes are set with pin 2.

Pin 2	Communications mode	Communications distance	Communications baud rate	Communications cycle time
OFF	High-speed Communications Mode	100 m max.	750 kbps	0.5 or 0.8 ms
ON	Long-distance Communications Mode	500 m max.	93.75 kbps	4.0 or 6.0 ms

The communications mode settings using pin 2 only apply to the SRT2-series Slaves and cannot be used with the SRT1-series Slaves, which operate in High-speed Communications Mode at all times.

Note Make sure that the communications mode of the Slave is the same as that of the Master Unit. If the communications modes are not the same, normal communications with the Master Unit will not be possible. The operating status of the Slave can be verified with LED indicators. Refer to 6-5-1 Indicators.

Node Number Settings

Set the node number with pins 3 through 6, as shown in the following table.

Node number	Pin 3 (8)	Pin 4 (4)	Pin 5 (2)	Pin 6 (1)
0	OFF	OFF	OFF	OFF
1	OFF	OFF	OFF	ON
2	OFF	OFF	ON	OFF
3	OFF	OFF	ON	ON
4	OFF	ON	OFF	OFF
5	OFF	ON	OFF	ON
6	OFF	ON	ON	OFF
7	OFF	ON	ON	ON
8	ON	OFF	OFF	OFF
9	ON	OFF	OFF	ON
10	ON	OFF	ON	OFF
11	ON	OFF	ON	ON
12	ON	ON	OFF	OFF
13	ON	ON	OFF	ON
14	ON	ON	ON	OFF
15	ON	ON	ON	ON

Note The actual node number setting range depends on the type of PLC in which the Master is mounted as well as the Master's settings. Refer to 2-1 Communications Specifications for details.

Internal Circuits

The following diagram shows the internal circuits for the SRT□-OD04.

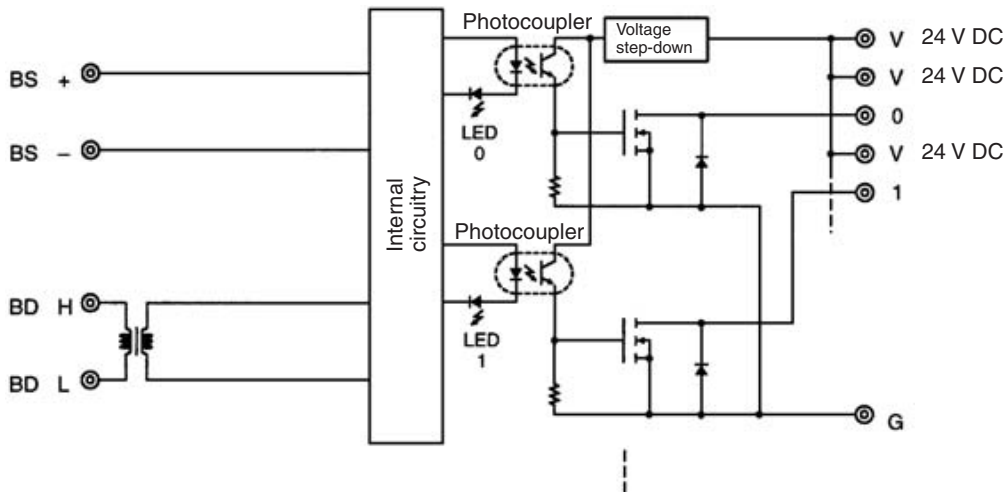

The following diagram shows the internal circuits for the SRT□-OD04-1.

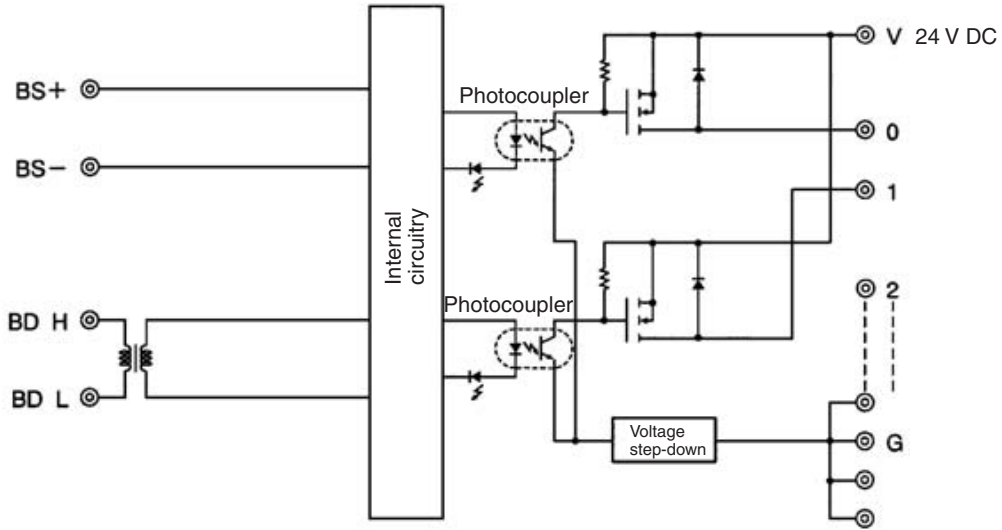

The following diagram shows the internal circuits for the SRT□-OD08.

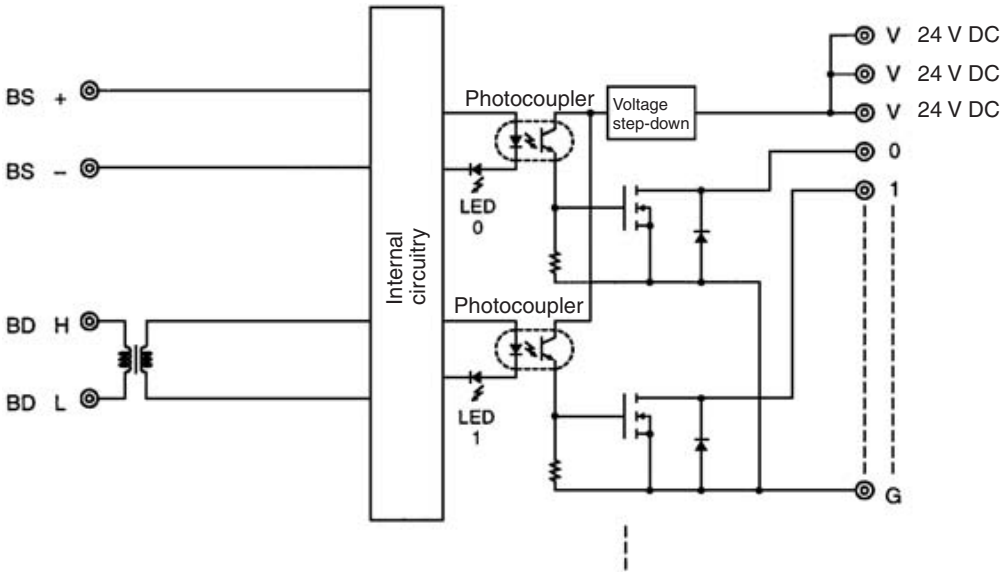

The following diagram shows the internal circuits for the SRT□-OD08-1.

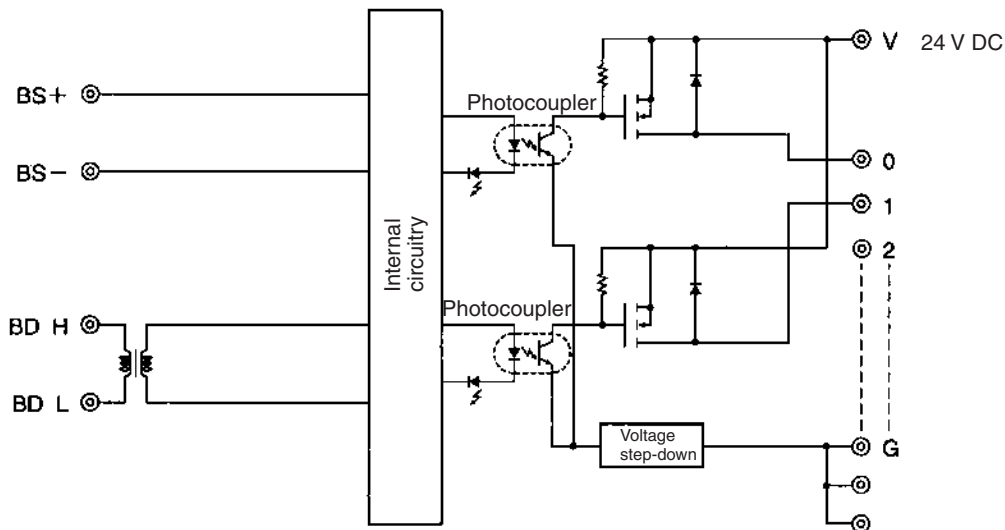

The following diagram shows the internal circuits for the SRT□-OD16.

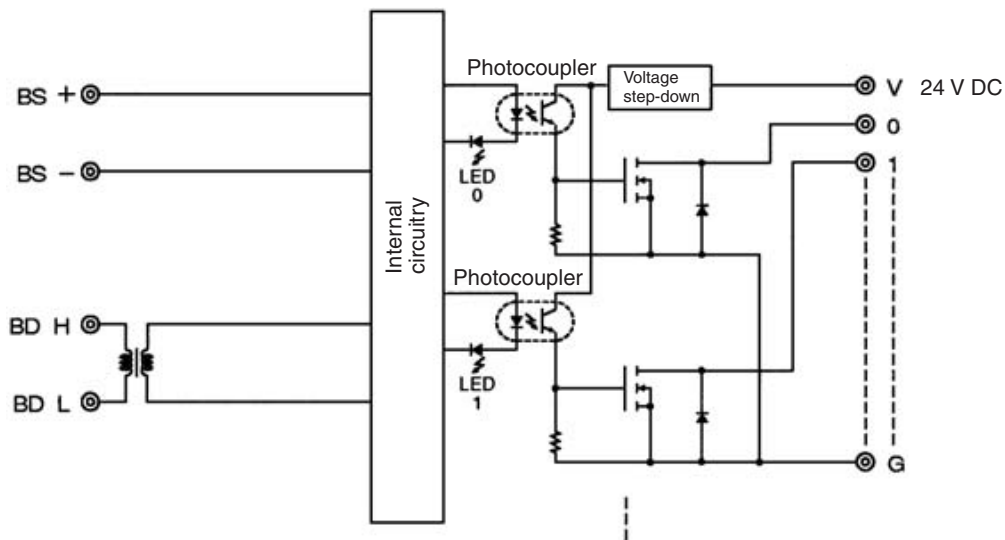

The following diagram shows the internal circuits for the SRT□-OD16-1.

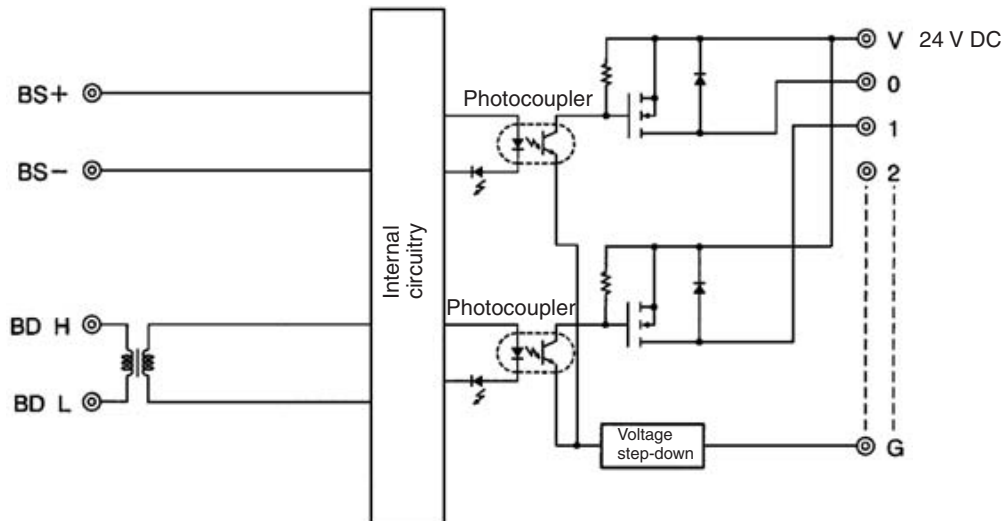

Terminal Arrangement and Wiring

Install the following M3 crimp terminals on the signal wires and connect to the terminal block.



Note Tighten the terminal block screws to the specified tightening torque of 0.5 N·m.

The following diagram shows the terminal arrangement and wiring for the SRT□-OD04.

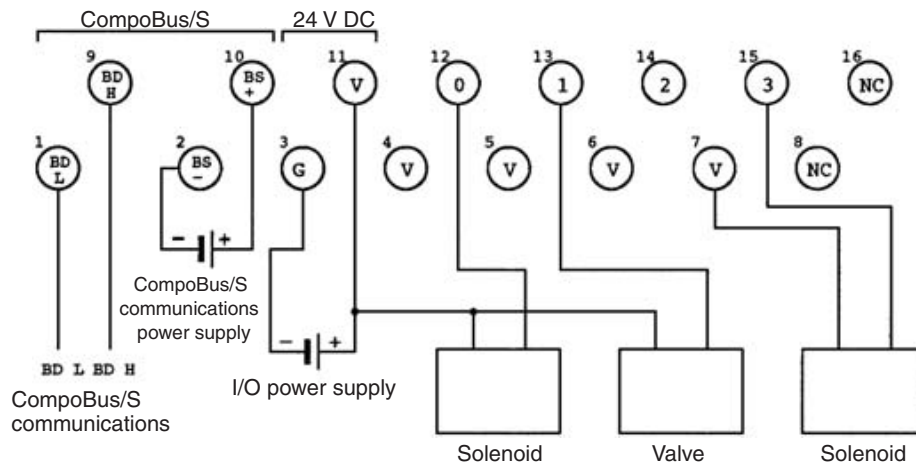

- Note**
1. The V terminals (terminal numbers 4, 5, 6, 7, and 11) are all connected internally. When I/O power is supplied to terminals 11 and 3, power can be supplied to output devices from terminals 4, 5, 6, and 7. When the power supply exceeds 1.0 A, provide an external power supply to the I/O power supply instead of providing the supply from the terminals.
 2. When inductive loads such as solenoids and valves are used, either use ones with built-in diodes that absorb the back-electromotive force or connect a diode externally.

The following diagram shows the terminal arrangement and wiring for the SRT□-OD04-1.

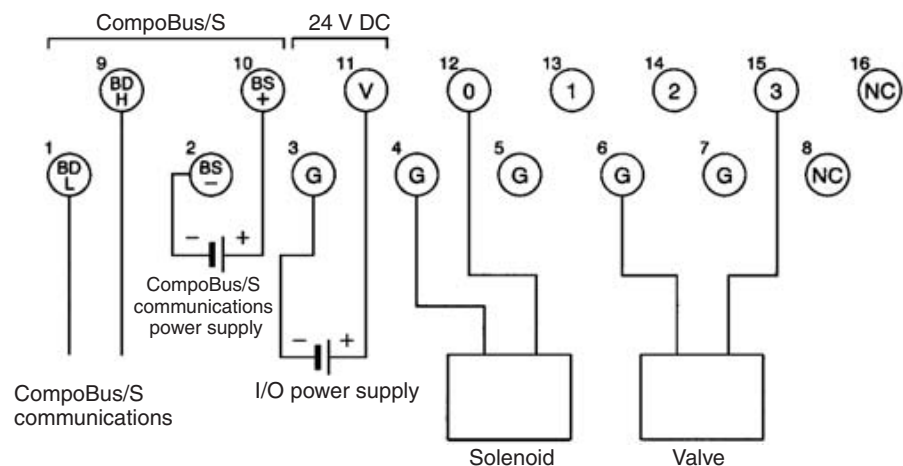

- Note**
1. G terminals (terminal numbers 3 and 4, 5, 6, 7) are all connected internally. When I/O power is supplied to terminals 11 and 3, power can be provided to output devices from terminals 4, 5, 6, and 7.

When the power supply exceeds 1.0 A, provide an external power supply to the I/O power supply instead of providing the supply from the terminals.

- When inductive loads such as solenoids and valves are used, either use loads with built-in diodes that absorb the back-electromotive force or connect a diode externally.

The following diagram shows the terminal arrangement and wiring for the SRT□-OD08.

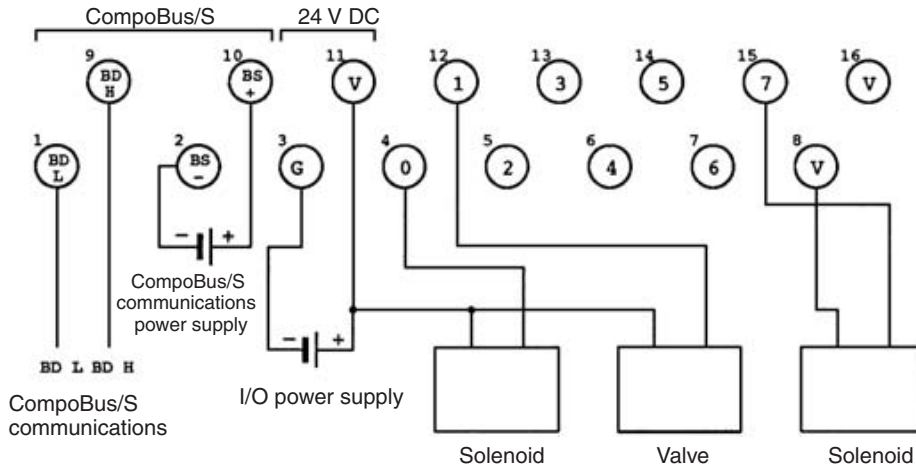

- Note**
- The V terminals (terminal numbers 11, 8, and 16) are all connected internally. When I/O power is supplied to terminal 11 and 3, power can be supplied to output devices from terminals 8 and 16. When the power supply exceeds 1.0 A, provide an external power supply to the I/O power supply instead of providing the supply from the terminals.
 - When inductive loads such as solenoids and valves are used, either use ones with built-in diodes that absorb the back-electromotive force or connect a diode externally.

The following diagram shows the terminal arrangement and wiring for the SRT□-OD08-1.

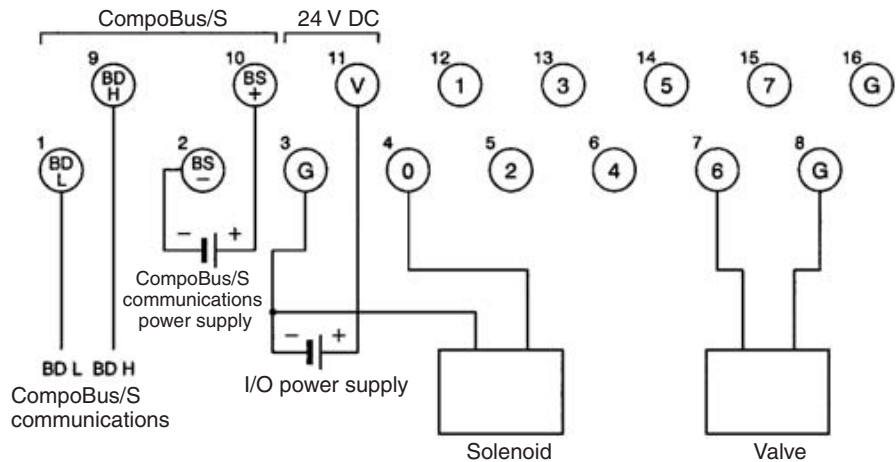

- Note**
- G terminals (terminal numbers 3 and 8 and 16) are all connected internally. When I/O power is supplied to terminals 11 and 3, power can be provided to output devices from terminal 8 or 16. When the power supply exceeds 1.0 A, provide an external power supply to the I/O power supply instead of providing the supply from the terminals.

- When inductive loads such as solenoids and valves are used, either use loads with built-in diodes that absorb the back-electromotive force or connect a diode externally.

The following diagram shows the terminal arrangement and wiring for the SRT□-OD16.

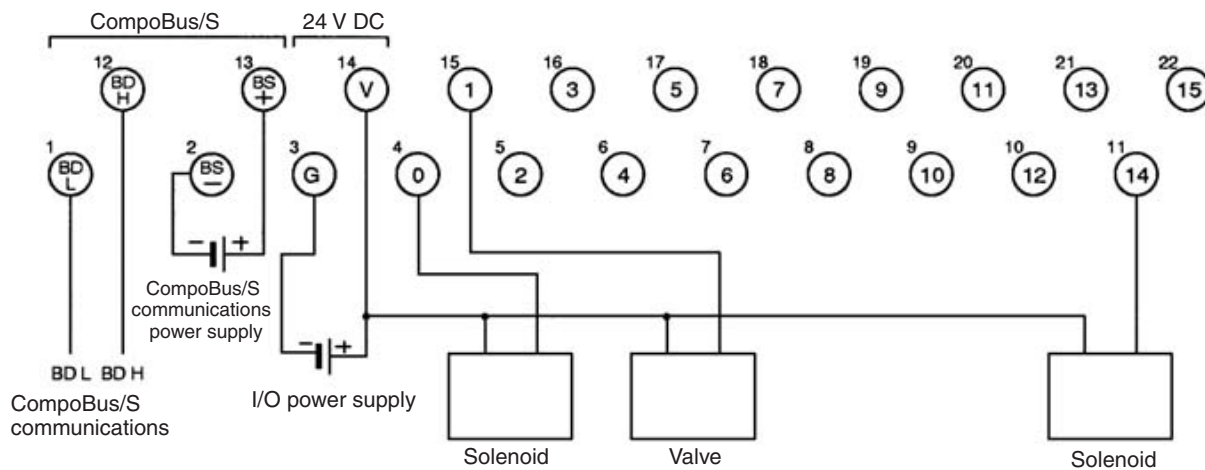

Note When inductive loads such as solenoids and valves are used, either use ones with built-in diodes that absorb the back-electromotive force or connect a diode externally.

The following diagram shows the terminal arrangement and wiring for the SRT□-OD16-1.

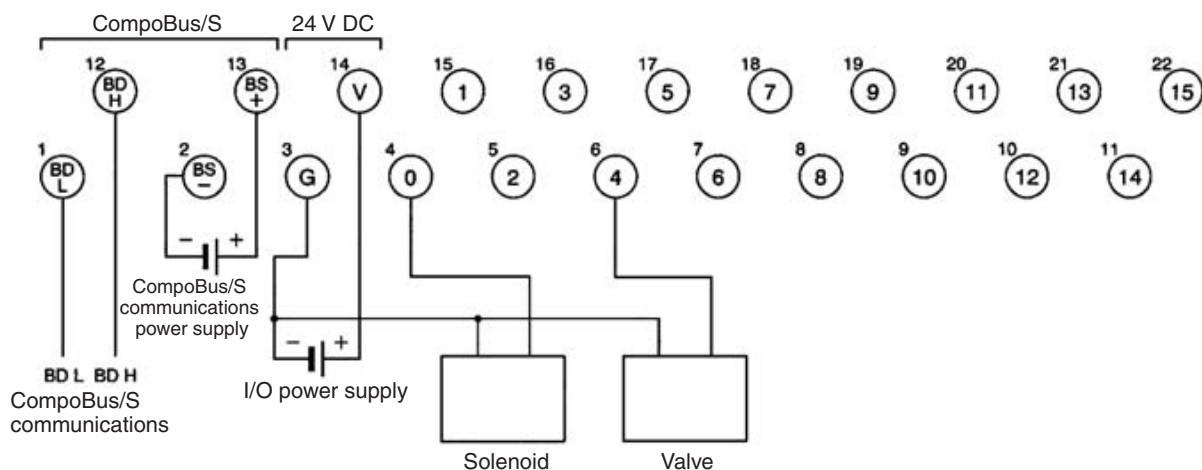

Note When inductive loads such as solenoids and valves are used, either use loads with built-in diodes that absorb the back-electromotive force or connect a diode externally.

**SRT□-OD04/OD04-1/
OD08/OD08-1 Dimensions**

The following diagram shows the dimensions for the SRT□-OD04/OD04-1/OD08/OD08-1. All dimensions are in mm.

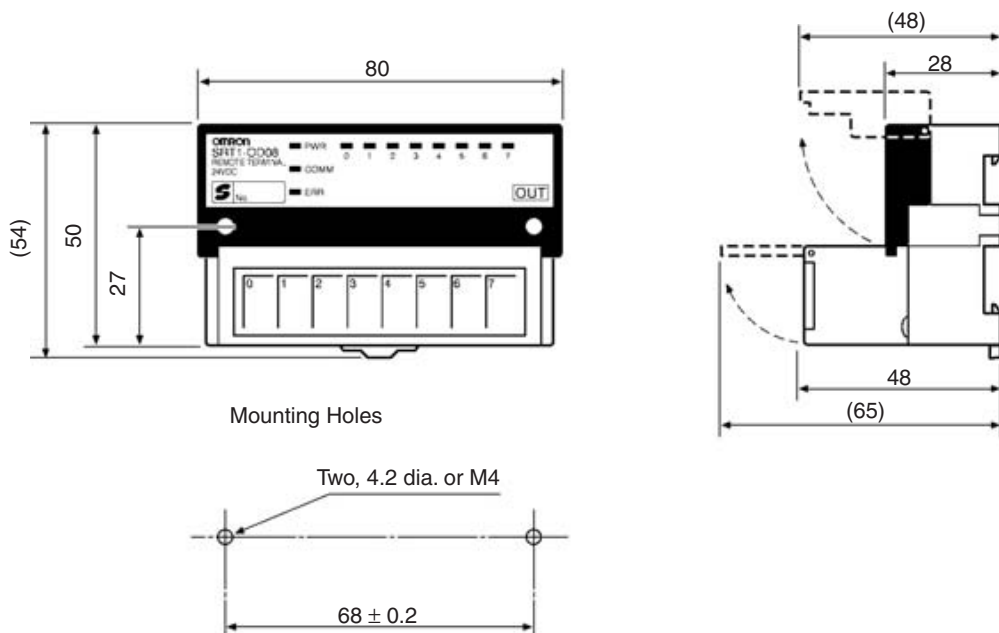

**SRT□-OD16/OD16-1
Dimensions**

The following diagram shows the dimensions for the SRT□-OD16/OD16-1. All dimensions are in mm.

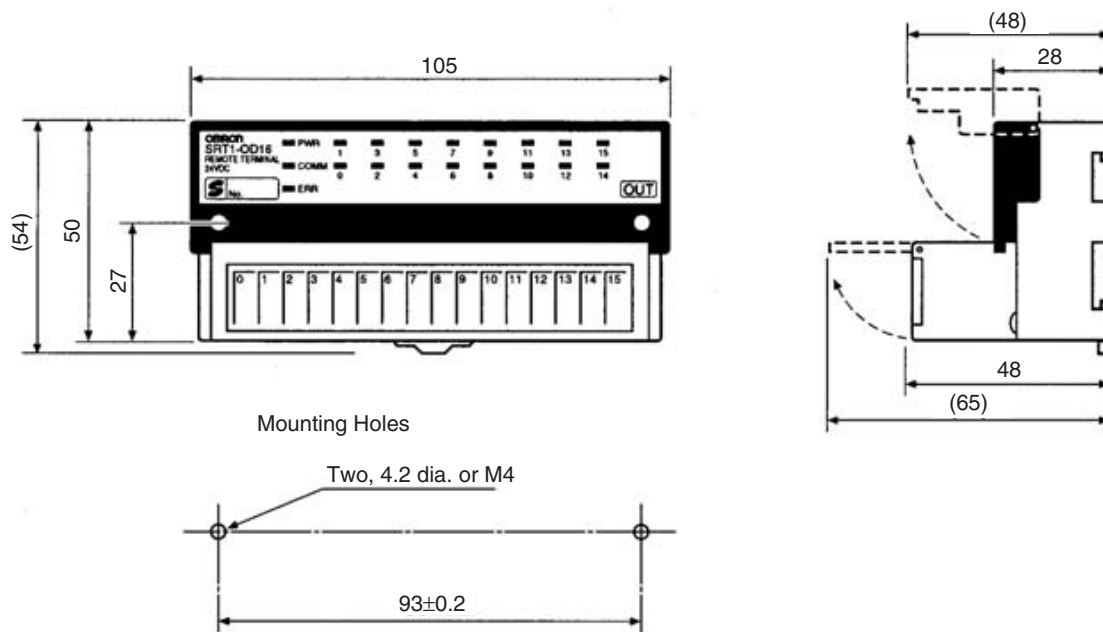

5-1-4 SRT□-OD16T (-1) Remote Terminals with 16 Transistor Outputs (and 3-tier Terminal Blocks)

Specifications

The following tables show the ratings and output specifications for the SRT□-OD16T (-1).

Ratings

Item	Specification
Models	SRT1-OD16T SRT1-OD16T-1 SRT2-OD16T SRT2-OD16T-1
Output points	SRT□-OD16T: 16 points (NPN) SRT□-OD16T-1: 16 points (PNP)
Communications mode	SRT1-OD16T (-1): High-speed Communications Mode SRT2-OD16T (-1): High-speed Communications Mode and Long-distance Communications Mode
Terminals	3-tier terminal block (with common I/O terminal for each output point)
Power supply type	Multiple power supplies
Communications power supply voltage	14 to 26.4 V DC (Power can be supplied from the communications cable)
I/O power supply voltage	20.4 to 26.4 V DC (24 V DC $+10\%$ / -15%)
Current consumption (See note.)	Communications power: 50 mA max. at 24 V DC
Noise immunity	± 1.5 kVp-p with a pulse width of 0.1 to 1 μ s and a rise time of 1 ns (via impulse noise simulator)
Vibration resistance	10 to 150 Hz, 1.0-mm double amplitude or 70 m/s ²
Shock resistance	Malfunction: 200 m/s ² Destruction: 300 m/s ²
Dielectric strength	500 V AC for 1 minute (between insulated circuits) 1,000 V AC for 1 minute (1-mA sensing current between charged and uncharged sections)
Ambient temperature	Operating: 10 to 55°C (with no icing or condensation) Storage: -20 to 65°C (with no icing or condensation)
Ambient humidity	Operating: 25% to 85% (with no condensation) Storage: 25% to 85% (with no condensation)
Operating environment	No corrosive gases
Mounting method	M4 screws or 35-mm DIN track mounting
Mounting strength	100 N in each direction
Terminal strength	Pulling: 100 N Tightening: 0.3 to 0.5 N • m
Node number settings	The node number is set with a rotary switch. (Set the node number before turning ON the Slave.)
Weight	Approx. 300 g

Note The current consumption is the value with all 16 points turned ON excluding the current consumption of the external sensor connected to the input Remote Terminal and the current consumption of the load connected to the output Remote Terminal.

Output Specifications

Item	Specification
Output current	0.5 A/point
Residual voltage	1.2 V max. (SRT□-OD16T: 0.5 A DC, between each output terminal and G) (SRT□-OD16T-1: 0.5 A DC, between each output terminal and V)
Leakage current	0.1 mA max.
ON delay time	0.5 ms max.
OFF delay time	1.5 ms max.
Insulation method	Photocoupler
Input indicators	LED (yellow)

Slave Components

The following diagram shows the main components of the SRT□-ID16T (-□) Remote Terminal. The functions of these components are described below.

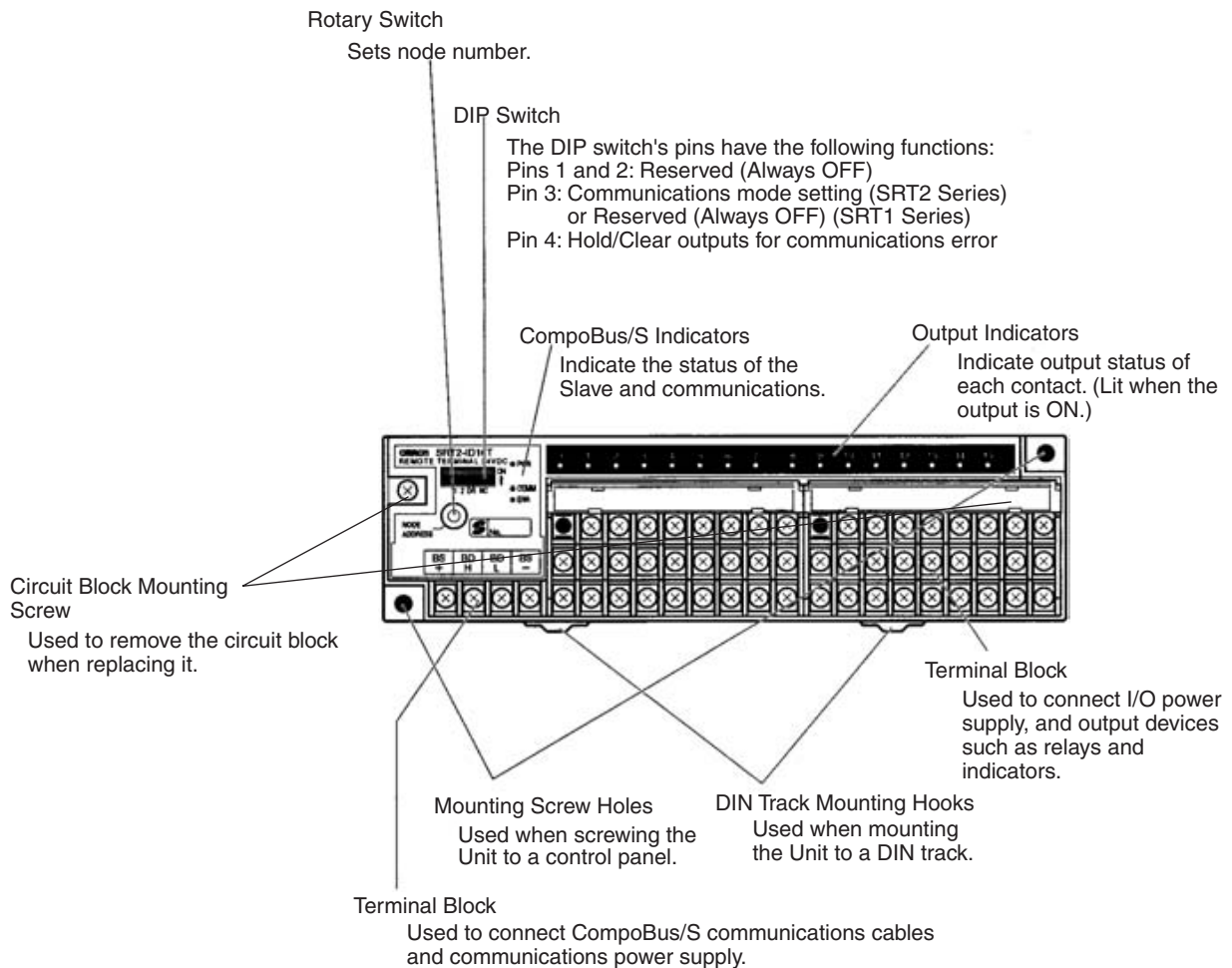

Indicators

The following table shows the meaning of the indicators.

Indicator	Status	Meaning
PWR (green)	ON	The communications power supply is ON.
	OFF	The communications power supply is OFF.
COMM (yellow)	ON	Normal communications
	OFF	A communications error has occurred or the Unit is in standby status.
ERR (red)	ON	A communications error has occurred.
	OFF	Normal communications or the Unit is in standby status.
0 to 15 (16 points.) (yellow)	ON	The corresponding input is ON.
	OFF	The corresponding input is OFF or the Unit is in standby status.

Switch Settings

Rotary and DIP switches are used to enter settings.

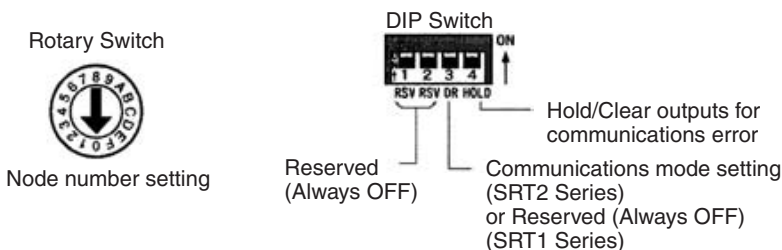

- Note**
1. Always turn OFF the Slave before changing DIP switch settings.
 2. In the SRT1 Series, pin 3 must always be left OFF. Otherwise, the Unit may not function correctly.
 3. All pins marked “RSV” (reserved) must be left OFF. If any of them is ON, the Unit may not function correctly.

Node Number Settings

The rotary switch specifies node numbers as hexadecimal numbers, as shown below.

Node number	Setting (Hexadecimal)	Node number	Setting (Hexadecimal)
0	0	8	8
1	1	9	9
2	2	10	A
3	3	11	B
4	4	12	C
5	5	13	D
6	6	14	E
7	7	15	F

- Note**
1. Node numbers of 16-point Slaves are always treated as even numbers. Even if an odd number is specified, the actual node number setting becomes the even number immediately preceding it.
 2. The actual node number setting range depends on the type of PLC in which the Master is mounted as well as the Master’s settings. Refer to 2-1 *Communications Specifications* for details.

Communications Mode Settings (SRT2 Series Only)

The communications mode is set with pin 3, as shown below.

Pin 3	Communications mode	Communications distance	Communications baud rate	Communications cycle time
OFF	High-speed Communications Mode	100 m max.	750 kbps	0.5 or 0.8 ms
ON	Long-distance Communications Mode	500 m max.	93.75 kbps	4.0 or 6.0 ms

The communications mode settings using pin 3 only apply to the SRT2-series Slaves and cannot be used with the SRT1-series Slaves, which operate in High-speed Communications Mode at all times.

Hold/Clear Outputs for Communications Error

Pin 4 is used to set the output data status when a communications error occurs, as shown in the following table.

Pin 4 (HOLD)	Setting
OFF	Clear output
ON	Hold output

Internal Circuits

The following diagram shows the internal circuits for the SRT□-OD16T.

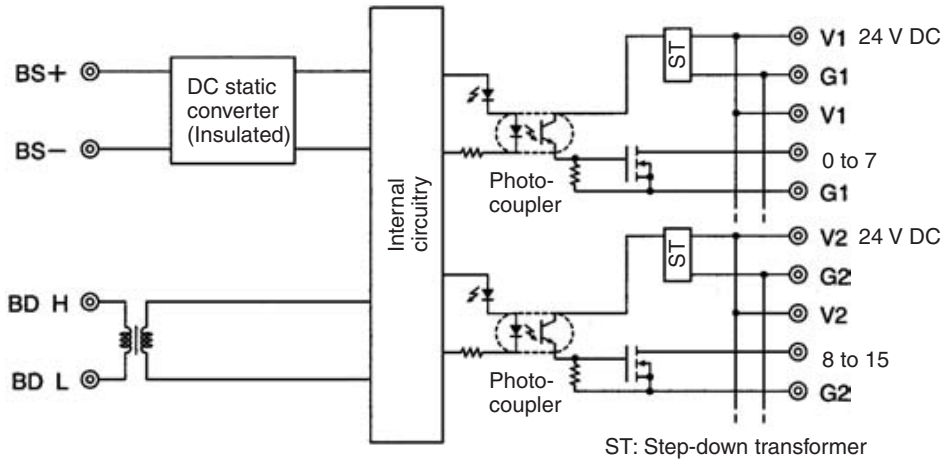

The following diagram shows the internal circuits for the SRT□-OD16T-1.

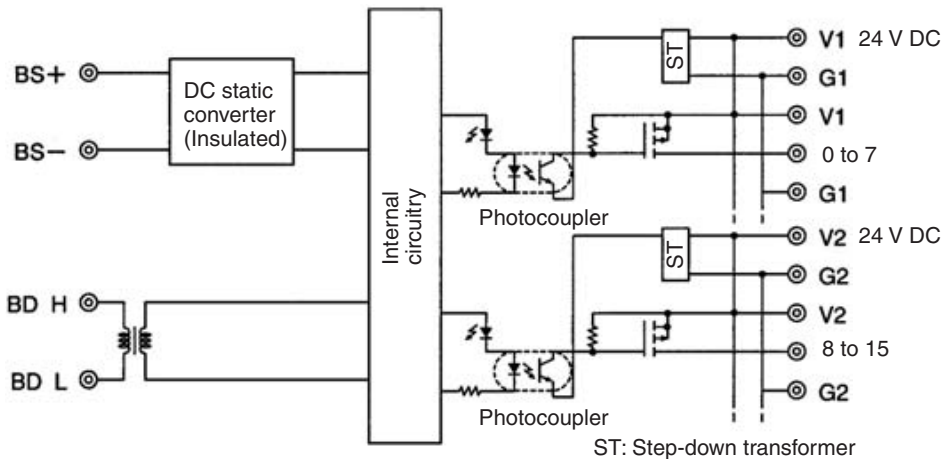

Terminal Arrangement and Wiring

Install the following M3 crimp terminals on the signal wires and connect to the terminal block.



Note Tighten the terminal block screws to the specified tightening torque of 0.5 N·m.

The following diagram shows the terminal arrangement and wiring for the SRT□-OD16T.

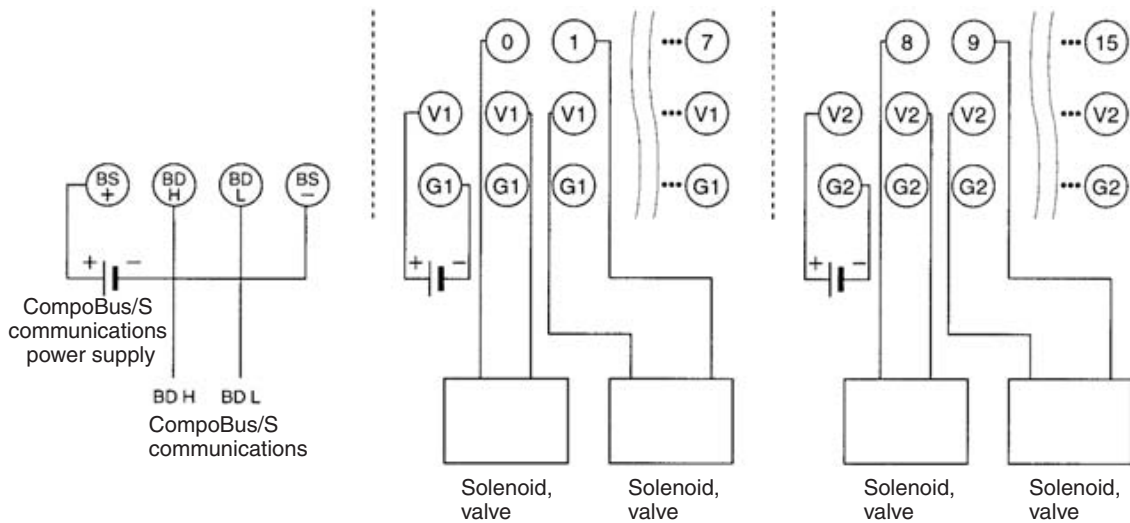

The following diagram shows the terminal arrangement and wiring for the SRT□-OD16T-1.

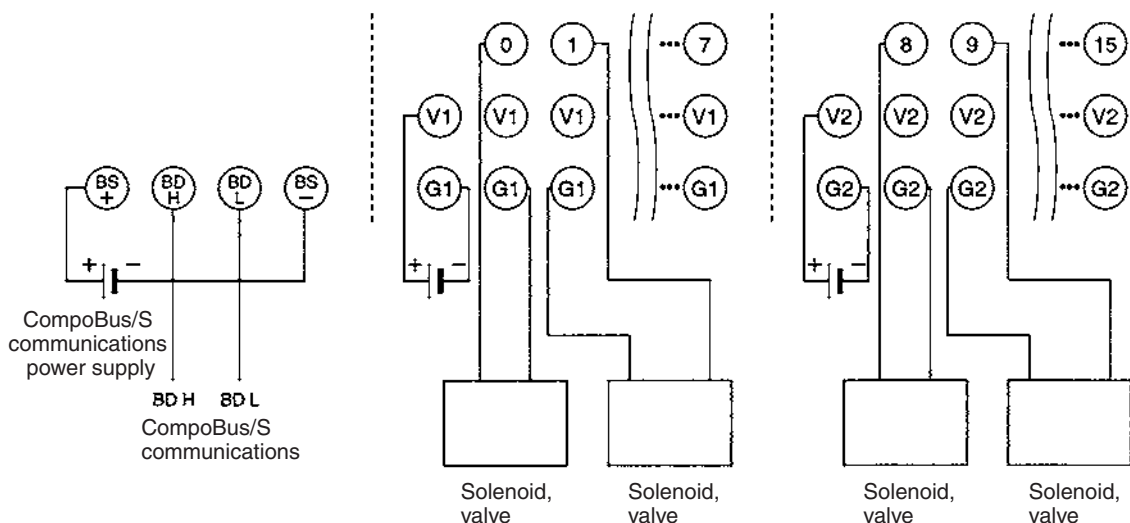

- Note**
1. The V terminals V1 and V2 are not connected internally, and neither are the G terminals G1 and G2 (I/O power supply). Care must be taken when connecting them.
 2. Do not allow the current between V1 and G1 or between V2 and G2 to exceed 4 A.
 3. When using inductive loads such as solenoids and valves, either use loads with built-in diodes that absorb the back-electromotive force or connect a diode externally.

SRT□-OD16T/OD16T-1
Dimensions

The following diagram shows the dimensions for the SRT□-OD16T/OD16T-1. All dimensions are in mm.

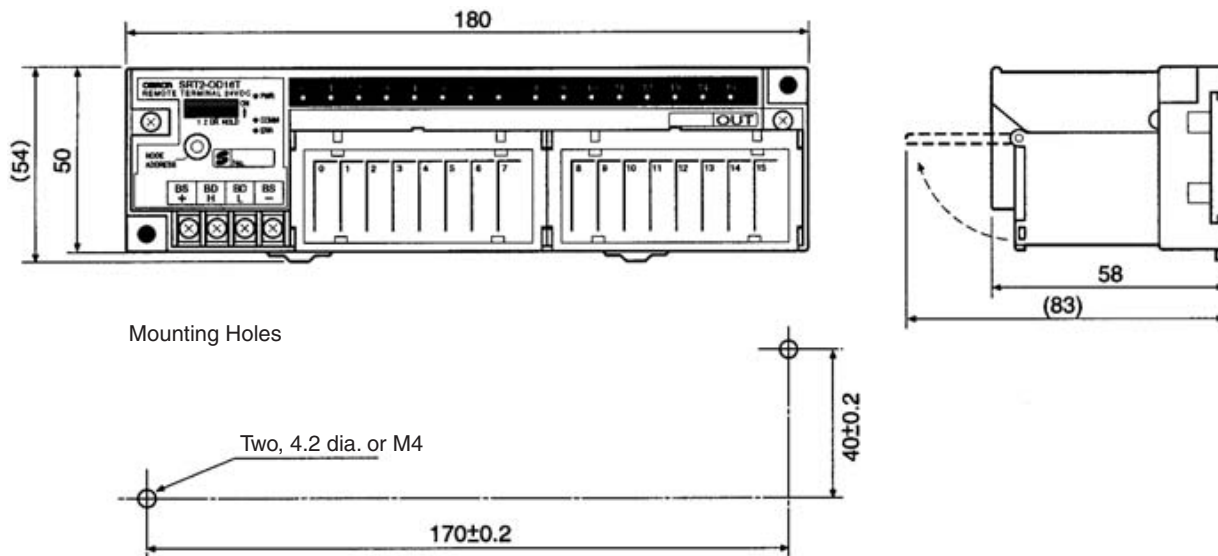

Note The circuit block can be removed by loosening the circuit block mounting screw. Before removing the circuit block for replacement, check that all power supplies, including I/O power supply, to the Unit are turned OFF.

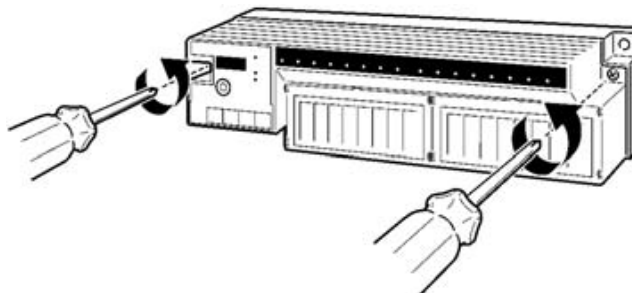

5-1-5 SRT□-MD16T (-1) Remote Terminals with 8 Input and 8 Output Transistors (3-tier Terminal Block)

Specifications

The following tables show the ratings and I/O specifications for the SRT□-MD16T (-1).

Ratings

Item	Specification
Models	SRT1-MD16T SRT1-MD16T-1 SRT2-MD16T SRT2-MD16T-1
I/O points	SRT□-MD16T: 8 inputs, 8 outputs SRT□-MD16T-1: 8 inputs, 8 outputs
Communications mode	SRT1-MD16T (-1): High-speed Communications Mode SRT2-MD16T (-1): High-speed Communications Mode and Long-distance Communications Mode
Terminals	3-tier terminal block (with common I/O terminal for each I/O point)
Power supply type	Multiple power supplies
Communications power supply voltage	14 to 26.4 V DC (Power can be supplied from the communications cable)
I/O power supply voltage	20.4 to 26.4 V DC (24 V DC $+10\%$ / -15%)
Current consumption (See note.)	Communications power: 50 mA max. at 24 V DC
Noise immunity	± 1.5 kVp-p with a pulse width of 0.1 to 1 μ s and a rise time of 1 ns (tested with impulse noise simulator)
Vibration resistance	10 to 150 Hz, 1.0-mm double amplitude or 70 m/s ²
Shock resistance	Malfunction: 200 m/s ²
Dielectric strength	500 V AC (between insulated circuits)
Ambient temperature	Operating: -10 to 55°C (with no icing or condensation) Storage: -20 to 65°C (with no icing or condensation)
Ambient humidity	Operating: 25% to 85% (with no condensation) Storage: 25% to 85% (with no condensation)
Operating environment	No corrosive gases
Mounting method	M4 screws or 35-mm DIN track mounting
Mounting strength	100 N in each direction
Terminal strength	Pulling: 100 N Tightening: 0.3 to 0.5 N • m
Node number settings	The node number is set with a rotary switch. (Set the node number before turning ON the Slave.)
Weight	Approx. 300 g

Note The current consumption is the value with all 16 points turned ON excluding the current consumption of the external sensor connected to the input Remote Terminal and the current consumption of the load connected to the output Remote Terminal.

Input Specifications

Item	Specification
Input current	6 mA max./point at 24 V DC 3 mA min./point at 17 V DC
ON delay time	1.5 ms max.
OFF delay time	1.5 ms max.
ON voltage	SRT□-MD16T: 15 V DC min. (between each input terminal and V) SRT□-MD16T-1: 15 V DC min. (between each input terminal and G)
OFF voltage	SRT□-MD16T: 5 V DC max. (between each terminal and V) SRT□-MD16T-1: 5 V DC max. (between each terminal and G)
OFF current	1 mA max. at 24 V DC
Insulation method	Photocoupler
Input indicators	LED (yellow)

Output Specifications

Item	Specification
Output current	0.5 A/point
Residual voltage	1.2 V max. (SRT□-MD16T: 0.5 A DC, between each output terminal and G) (SRT□-MD16T-1: 0.5 A DC, between each output terminal and V)
Leakage current	0.1 mA max.
ON delay time	0.5 ms max.
OFF delay time	1.5 ms max.
Insulation method	Photocoupler
Input indicators	LED (yellow)

Slave Components

The following diagram shows the main components of the SRT□-MD16T (-□) Remote Terminal. The functions of these components are described below.

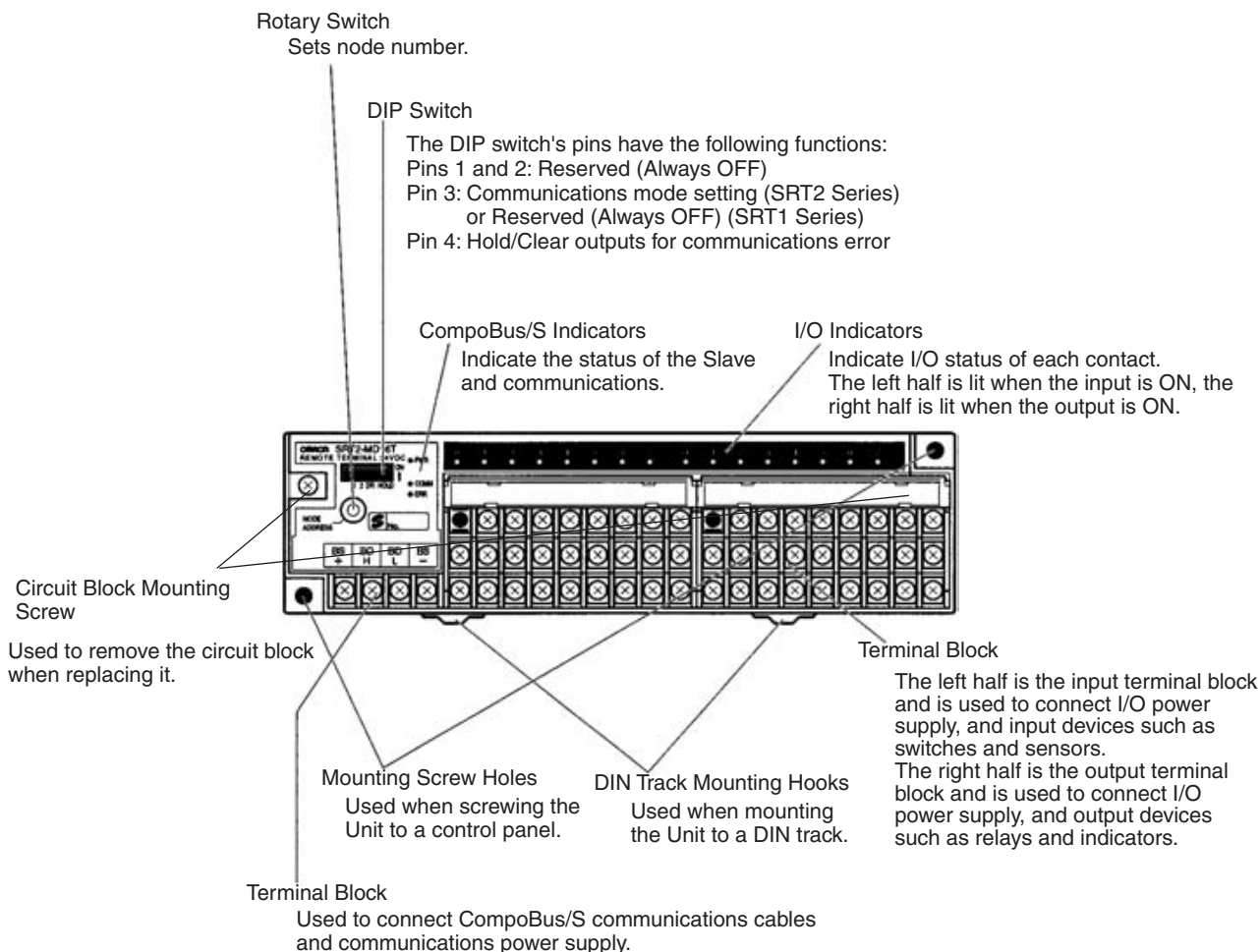

Indicators

The following table shows the meaning of the indicators.

Indicator	Status	Meaning
PWR (green)	ON	The communications power supply is ON.
	OFF	The communications power supply is OFF.
COMM (yellow)	ON	Normal communications
	OFF	A communications error has occurred or the Unit is in standby status.
ERR (red)	ON	A communications error has occurred.
	OFF	Normal communications or the Unit is in standby status.
0 to 7 (8 inputs) 0 to 7 (8 outputs) (yellow)	ON	The corresponding input is ON.
	OFF	The corresponding input is OFF or the Unit is in standby status.

Switch Settings

Rotary and DIP switches are used to enter settings.

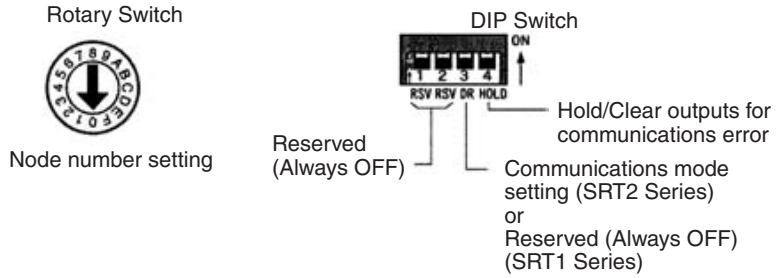

- Note**
1. Always turn the Slave OFF before changing DIP switch settings.
 2. In the SRT1 Series, pin 3 must always be left OFF. Otherwise, the Unit may not function correctly.
 3. All pins marked “RSV” (reserved) must be left OFF. If any of them is ON, the Unit may not function correctly.

Node Number Settings

The rotary switch specifies node numbers as hexadecimal numbers, as shown below.

Node number	Setting (Hexadecimal)	Node number	Setting (Hexadecimal)
0	0	8	8
1	1	9	9
2	2	10	A
3	3	11	B
4	4	12	C
5	5	13	D
6	6	14	E
7	7	15	F

- Note**
1. A 16-point I/O Slave is handled as a single 8-point Input Slave and a single 8-point Output Slave that possess the same node number.
 2. The actual node number setting range depends on the type of PLC in which the Master is mounted as well as the Master’s settings. Refer to *2-1 Communications Specifications* for details.

Communications Mode Settings (SRT2 Series Only)

The communications mode is set with pin 3, as shown below.

Pin 3	Communications mode	Communications distance	Communications baud rate	Communications cycle time
OFF	High-speed Communications Mode	100 m max.	750 kbps	0.5 or 0.8 ms
ON	Long-distance Communications Mode	500 m max.	93.75 kbps	4.0 or 6.0 ms

The communications mode settings using pin 3 only apply to the SRT2 Series and cannot be used with the SRT1 Series, which operate in High-speed Communications Mode at all times.

Hold/Clear Outputs for Communications Error

Pin 4 is used to set the output data status when a communications error occurs, as shown in the following table.

Pin 4 (HOLD)	Setting
OFF	Clear output
ON	Hold output

Internal Circuits

The following diagram shows the internal circuits for the SRT□-MD16T.

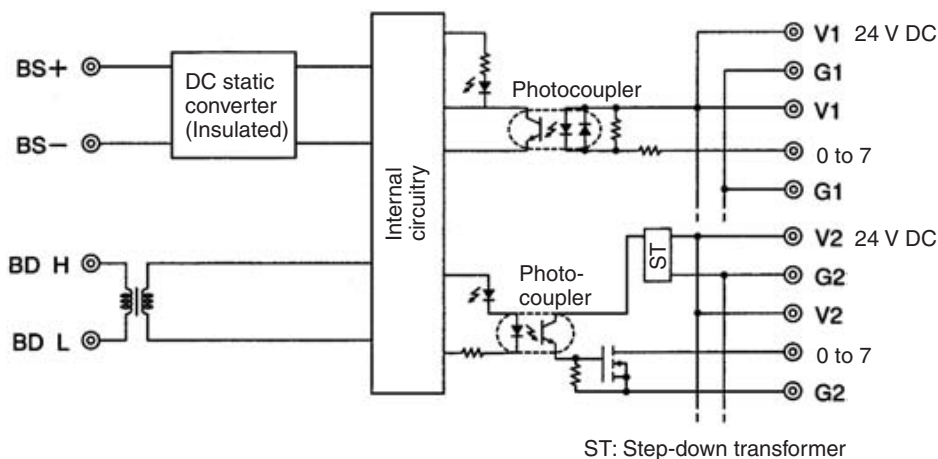

The following diagram shows the internal circuits for the SRT□-MD16T-1.

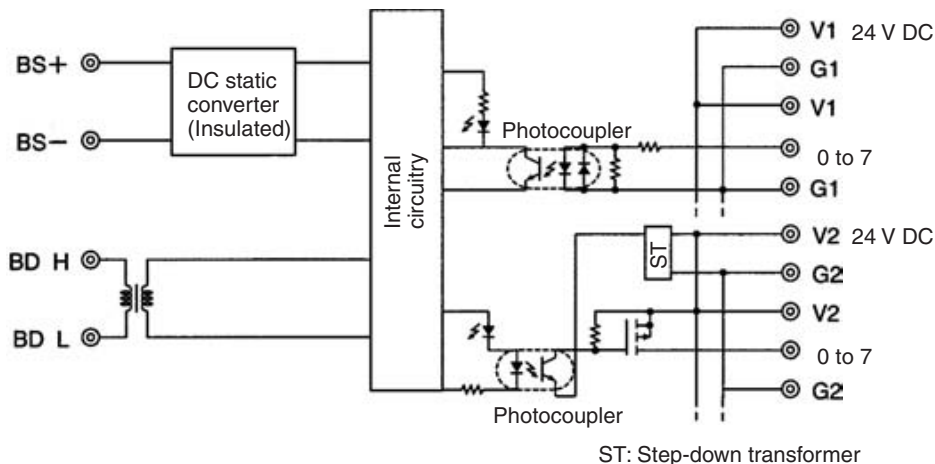

Terminal Arrangement and Wiring

Install the following M3 crimp terminals on the signal wires and connect to the terminal block, as shown in the following diagram.



Note Tighten the terminal block screws to the specified tightening torque of 0.5 N·m.

The following diagram shows the terminal arrangement and wiring for the SRT□-MD16T.

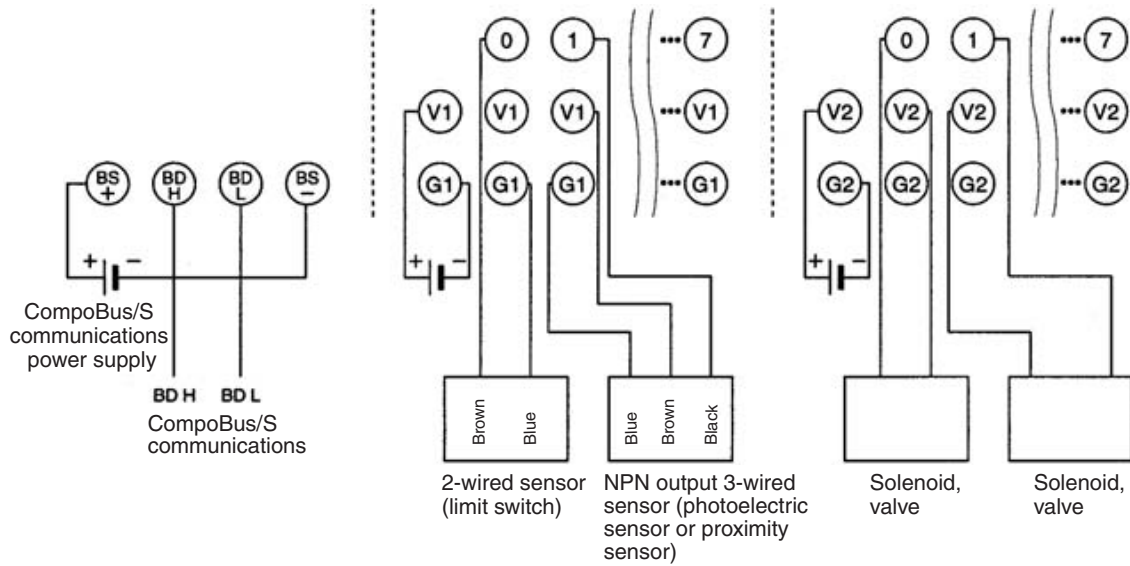

The following diagram shows the terminal arrangement and wiring for the SRT□-MD16T-1.

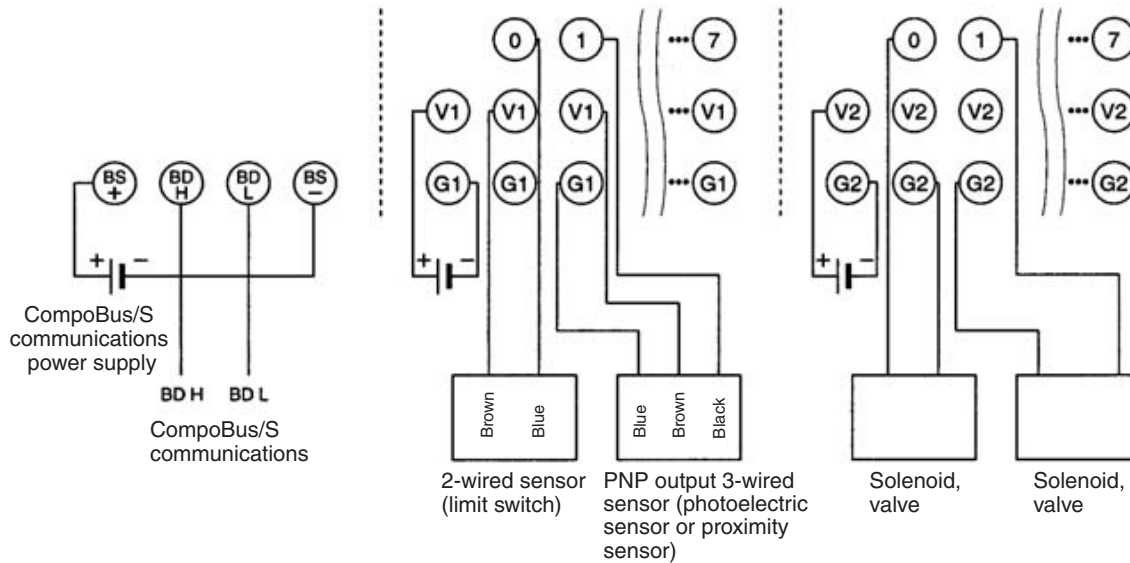

- Note**
1. The V terminals V1 and V2 are not connected internally, and neither are the G terminals G1 and G2 (I/O power supply). Care must be taken when connecting them.
 2. When inductive loads such as solenoids and valves are used, either use loads with built-in diodes that absorb the back-electromotive force or connect a diode externally.

SRT□-MD16T/MD16T-1 Dimensions

The following diagram shows the dimensions for the SRT□-MD16T/MD16T-1. All dimensions are in mm.

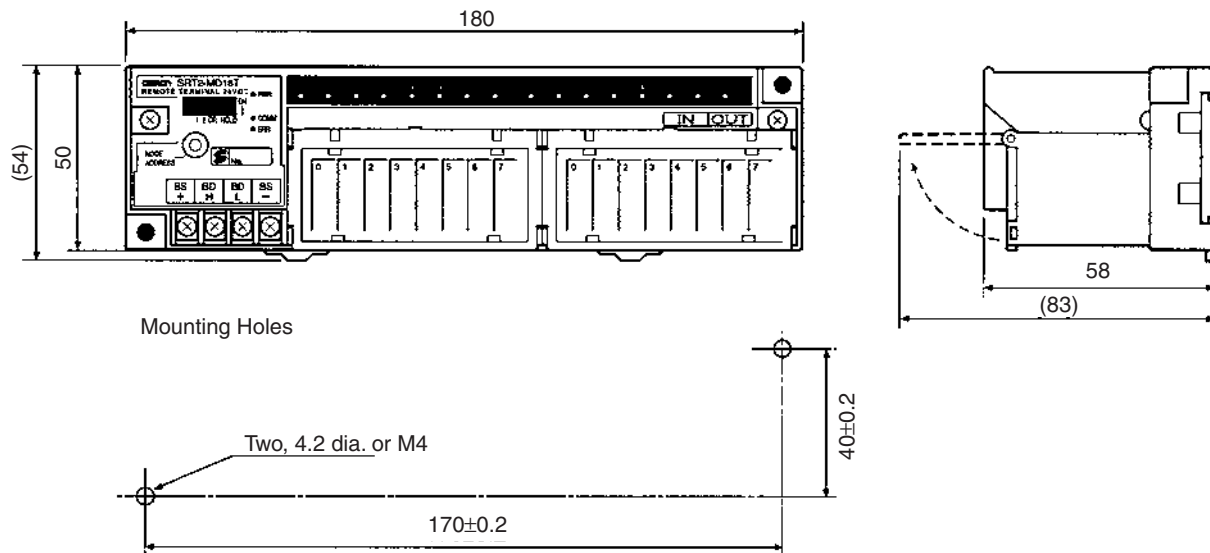

Note The circuit block can be removed by loosening the circuit block mounting screw. Before removing the circuit block for replacement, check that all power supplies, including I/O power supply, to the Unit are turned OFF.

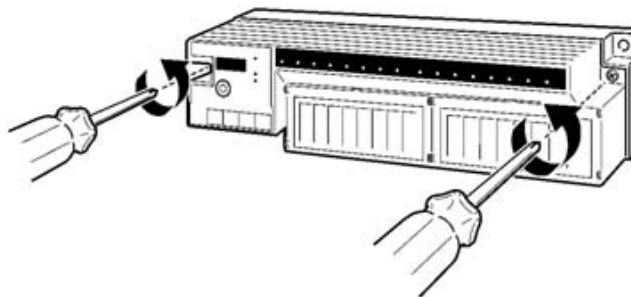

5-1-6 SRT□-RO□□□ Remote Terminals with Relay/Power MOS FETs

Specifications

The following tables and graphs show the ratings and output specifications for the SRT□-RO□□□.

Ratings

Item	Specification
Models	SRT1-ROC08 SRT1-ROF08 SRT1-ROC16 SRT1-ROF16 SRT2-ROC08 SRT2-ROF08 SRT2-ROC16 SRT2-ROF16
Output points	SRT□-ROC08: 8 relay outputs SRT□-ROF08: 8 power MOS FET outputs SRT□-ROC16: 16 relay outputs SRT□-ROF16: 16 power MOS FET outputs (The 16-output Remote Terminals cannot be used with a CQM1-SRM21 Master Unit that is in 4-point mode.)

Item	Specification
Communications mode	SRT1-RO□□□: High-speed Communications Mode SRT2-RO□□□: High-speed Communications Mode or Long-distance Communications Mode
Power supply type	Local power supply
Communications power supply voltage (including I/O power supply)	20.4 to 26.4 V DC (24 V DC $+10\%/_{-15\%}$) (Power cannot be supplied from the communications cable)
Current consumption	Internal circuits: 350 mA max. at 24 V DC (Including relay coil current)
Noise immunity	± 1.5 kVp-p with a pulse width of 0.1 to 1 μ s and a rise time of 1 ns (via impulse noise simulator)
Common terminal current (COM 0, 1, and 2 through 7)	3 A max.
Vibration resistance	10 to 55 Hz, 1.0-mm double amplitude
Shock resistance	Malfunction: 100 m/s ²
Dielectric strength	500 V AC (between insulated circuits) 2,000 V AC (between all output terminals and the power supply or between all communications terminals and all different-polarity contacts)
Insulation resistance	20 M Ω min. at 250 V DC (at the same locations as dielectric strength specs.)
Ambient temperature	Operating: 0 to 55°C (with no icing or condensation) Storage: -20 to 65°C (with no icing or condensation)
Ambient humidity	Operating: 35% to 85% (with no condensation) Storage: 25% to 85% (with no condensation)
Operating environment	No corrosive gases
Mounting method	M4 screws or 35-mm DIN track mounting
Mounting strength	50 N Track direction: 10 N • m
Terminal strength	Pulling: 50 N Tightening: 0.6 to 1.18 N • m
Node number settings	The node number is set on a DIP switch. (Set the node number before turning ON the Slave.)
Weight	SRT□-ROC08: 145 g max. SRT□-ROF08: 145 g max. SRT□-ROC16: 240 g max. SRT□-ROF16: 240 g max.

Relay Output Specifications (SRT□-ROC08, SRT□-ROC16)

Item	Specification
Applicable relay	G6D-1A (one for each output point)
Rated load	3 A at 250 V AC/3 A at 30 V DC (resistive loads)
Rated carry current	3 A
Max. contact voltage	250 V AC/30 V DC
Max. contact current	3 A
Max. switching capacity	730 VA (AC), 90 W (DC)
Min. permissible load	10 mA at 5 V DC This value fulfills the P reference value of opening/closing at a rate of 120 times per min.
Electrical life expectancy	100,000 operations min. (3 A at 250 V AC/3 A at 30 V DC, resistive loads at 1800 operations/hour) 300,000 operations min. (2 A at 250 V AC/2 A at 30 V DC, resistive loads at 1800 operations/hour)
Mechanical life expectancy	20,000,000 operations min. (at 18,000 operations/hour)

Power MOS FET Relay Output Specifications (SRT□-ROF08, SRT□-ROF16)

Item	Specification
Applicable relay	G3DZ-2R6PL (one for each output point)
Load voltage	3 to 264 V AC/3 to 125 V DC
Load current	100 μA to 0.3 A
Inrush current	6 A max. (10 ms)

Note Refer to the *PCB Relays Catalog (X33)* for the ratings of the G6D and G3DZ.

Reference Data

These graphs are based on actual measured values sampled from the production line. Treat the data as reference values because there is some variation in relay characteristics.

The following graphs show the characteristics for G6D-1A Relays installed in SRT1-ROC08 and SRT1-ROC16 Relay-mounted Remote Terminals.

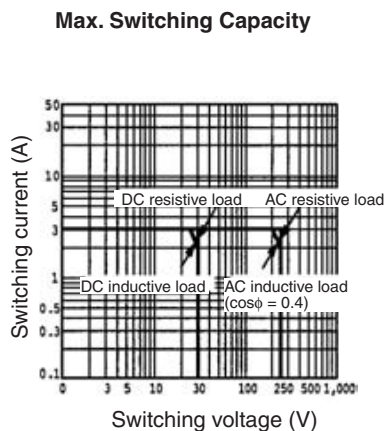
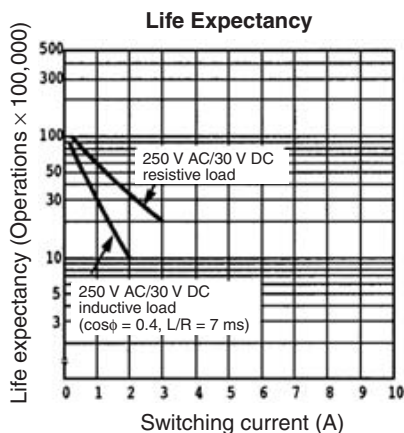

The following graphs show the characteristics for G3DZ-2R6PL Relays installed in SRT1-ROF08 and SRT1-ROF16 Relay-mounted Remote Terminals.

Load Current vs. Ambient Temperature Characteristics

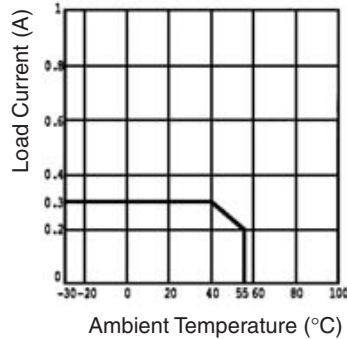

Inrush Current Limit

Non-repetitive (Keep the inrush current to half the rated value if it occurs repetitively.)

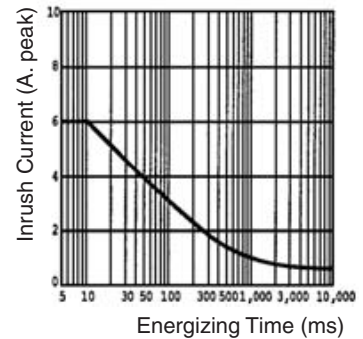

Slave Components

The following diagram shows the main components of the Relay-mounted Remote Terminals. The functions of these components are described below.

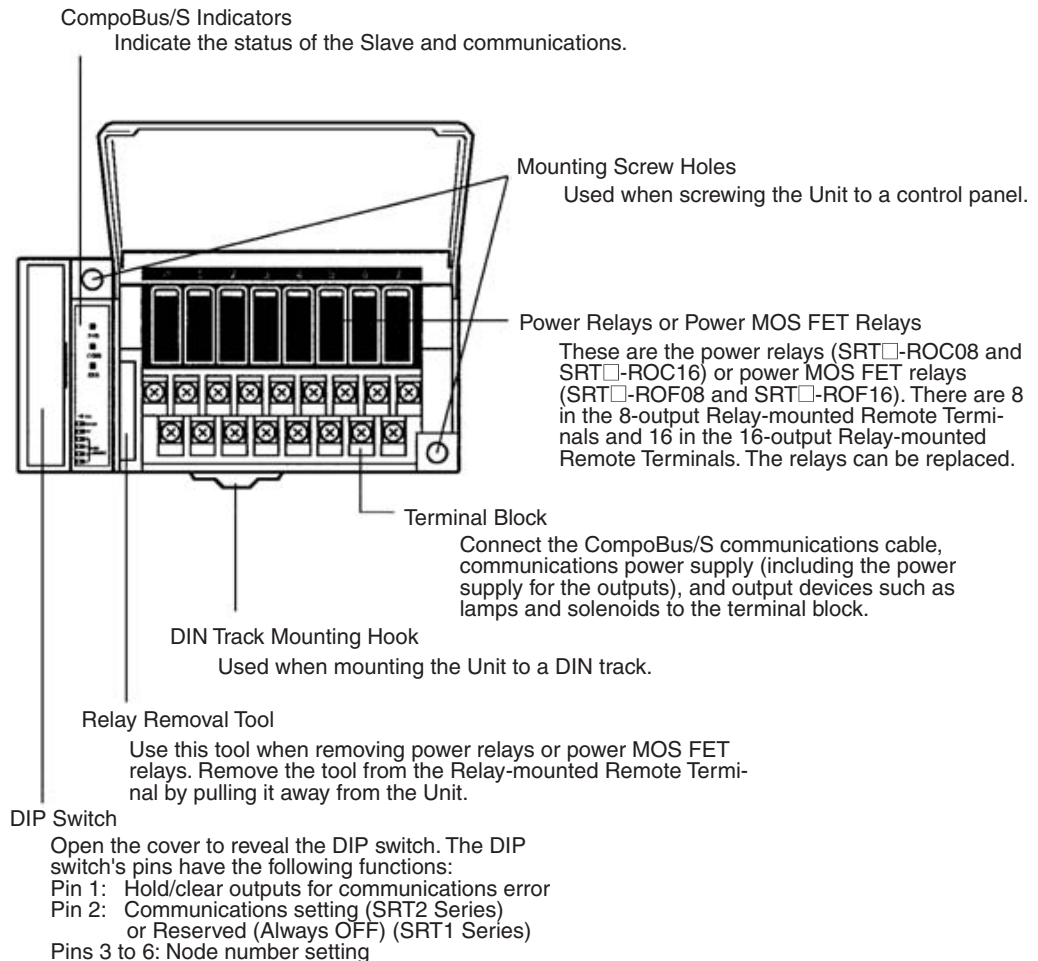

Indicators

The following table shows the meaning of the indicators.

Indicator	Status	Meaning
PWR (green)	ON	The communications power supply is ON.
	OFF	The communications power supply is OFF.
COMM (yellow)	ON	Normal communications
	OFF	A communications error has occurred or the Unit is in standby status.
ERR (red)	ON	A communications error has occurred.
	OFF	Normal communications or the Unit is in standby status.
0 to 7 (8 outputs) 0 to 15 (16 outputs) (yellow)	ON	The corresponding output is ON.
	OFF	The corresponding output is OFF or the Unit is in standby status.

DIP Switch

The DIP switch is located on the left side of the Relay-mounted Remote Terminal, under the cover. Always turn OFF the Slave before changing DIP switch settings.

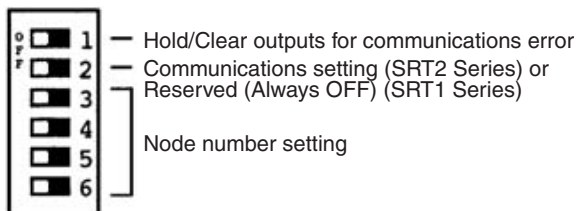

- Note**
1. Always turn OFF the Slave before changing DIP switch settings.
 2. In the SRT1 Series, pin 2 must always be left OFF. Otherwise, the Unit may not function correctly.

Hold/Clear Outputs for Communications Error

Pin 1 is used to set the output data status when a communications error occurs, as shown in the following table.

Pin 1 (HOLD)	Output setting
OFF	Clear output status.
ON	Maintain output status.

Communications Mode Setting (SRT2 Series Only)

The following communications modes are set with pin 2.

Pin 2	Communications mode	Communications distance	Communications baud rate	Communications cycle time
OFF	High-speed Communications Mode	100 m max.	750 kbps	0.5 or 0.8 ms
ON	Long-distance Communications Mode	500 m max.	93.75 kbps	4.0 or 6.0 ms

The communications mode settings using pin 2 only apply to the SRT2-series Slaves and cannot be used with the SRT1-series Slaves, which operate in High-speed Communications Mode at all times.

Note Make sure that the communications mode of the Slave is the same as that of the Master Unit. If the communications modes are not the same, normal communications with the Master Unit will not be possible. The operating status of the Slave can be verified with LED indicators. Refer to *6-5-1 Indicators*.

Node Number Settings

Set the node number with pins 3 through 6, as shown in the following table.

Node number	Pin 3 (8)	Pin 4 (4)	Pin 5 (2)	Pin 6 (1)
0	OFF	OFF	OFF	OFF
1	OFF	OFF	OFF	ON
2	OFF	OFF	ON	OFF
3	OFF	OFF	ON	ON
4	OFF	ON	OFF	OFF
5	OFF	ON	OFF	ON
6	OFF	ON	ON	OFF
7	OFF	ON	ON	ON
8	ON	OFF	OFF	OFF
9	ON	OFF	OFF	ON
10	ON	OFF	ON	OFF
11	ON	OFF	ON	ON
12	ON	ON	OFF	OFF
13	ON	ON	OFF	ON
14	ON	ON	ON	OFF
15	ON	ON	ON	ON

Note The actual node number setting range depends on the type of PLC in which the Master is mounted as well as the Master's settings. Refer to *2-1 Communications Specifications* for details.

Internal Circuits

The following diagram shows the internal circuits for all of the Relay/Power MOS FET Relay-mounted Remote Terminals (SRT□-ROC08/ROC16 and SRT□-ROF08/ROF16).

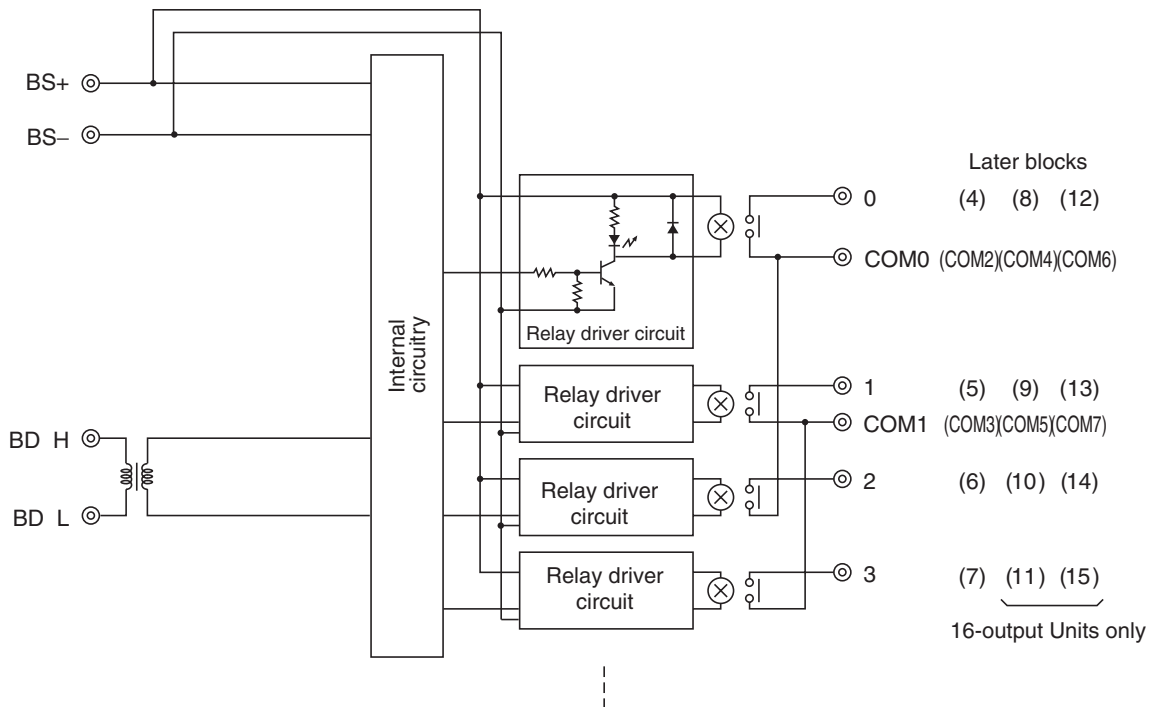

Terminal Arrangement and Wiring

Install the following M3 crimp terminals on the signal wires and connect to the terminal block.



Note Tighten the terminal block screws to the specified tightening torque of 0.5 N·m.

The following diagram shows the terminal arrangement and wiring for the 8-output Relay-mounted Remote Terminals (SRT□-ROC08 and SRT□-ROF08).

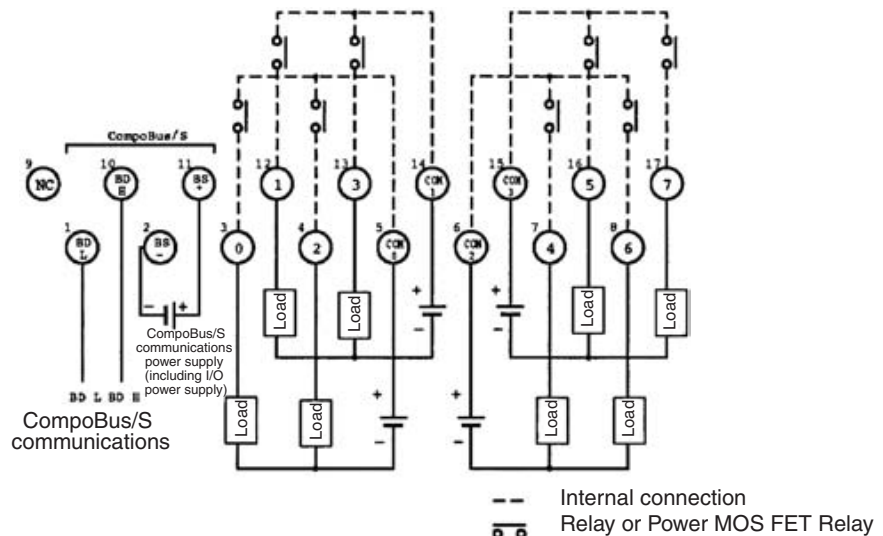

Note The BS+ and BS– terminals of the communications power supply (including the I/O power supply) cannot be supplied from the communications cable, so they must be supplied separately.

The following diagram shows the terminal arrangement and wiring for the 16-output Relay-mounted Remote Terminals (SRT□-ROC16 and SRT□-ROF16).

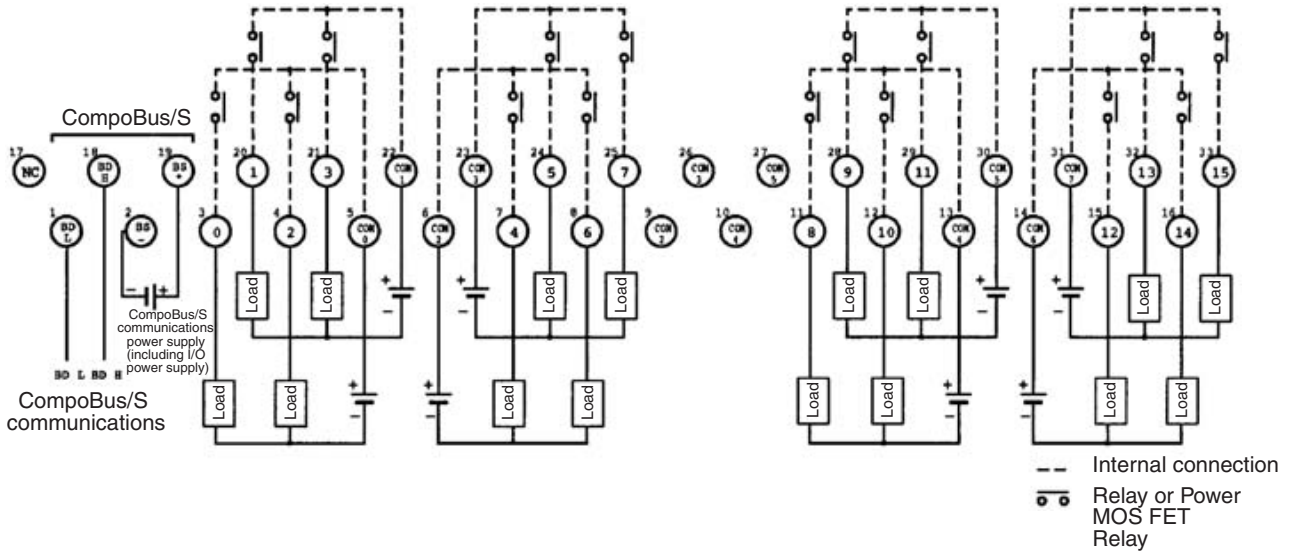

- Note**
1. There are two each of the COM2 and COM3 terminals, and two each of the COM4 and COM5 terminals. When power is supplied to all the terminals at once, wiring the COM terminals can be simplified by short-circuiting the central COM terminals.
 2. The maximum carry current for each terminal from COM0 to COM7 is 3 A. When power is supplied to all the terminals at once, the total carry current for the COM terminals connected together must not exceed 3 A.
 3. The BS+ and BS– terminals of the communications power supply (including the I/O power supply) cannot be supplied from the communications cable, so they must be supplied separately.

SRT□-ROC08/ROF08
Dimensions

The following diagram shows the dimensions for the 8-output Relay-mounted Remote Terminals (SRT□-ROC08 and SRT□-ROF08). All dimensions are in mm.

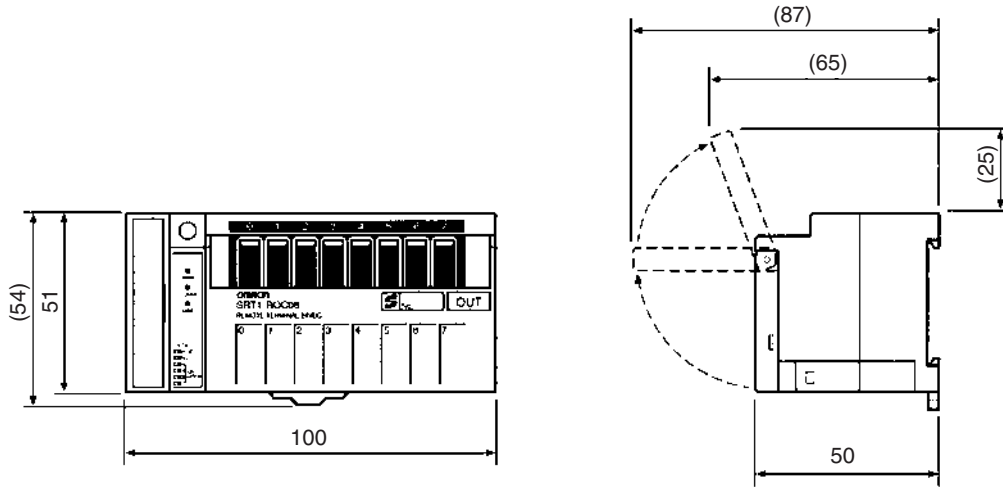

Mounting Holes

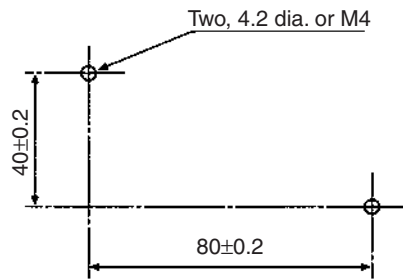

**SRT□-ROC16/ROF16
Dimensions**

The following diagram shows the dimensions for the 16-output Relay-mounted Remote Terminals (SRT□-ROC16 and SRT□-ROF16). All dimensions are in mm.

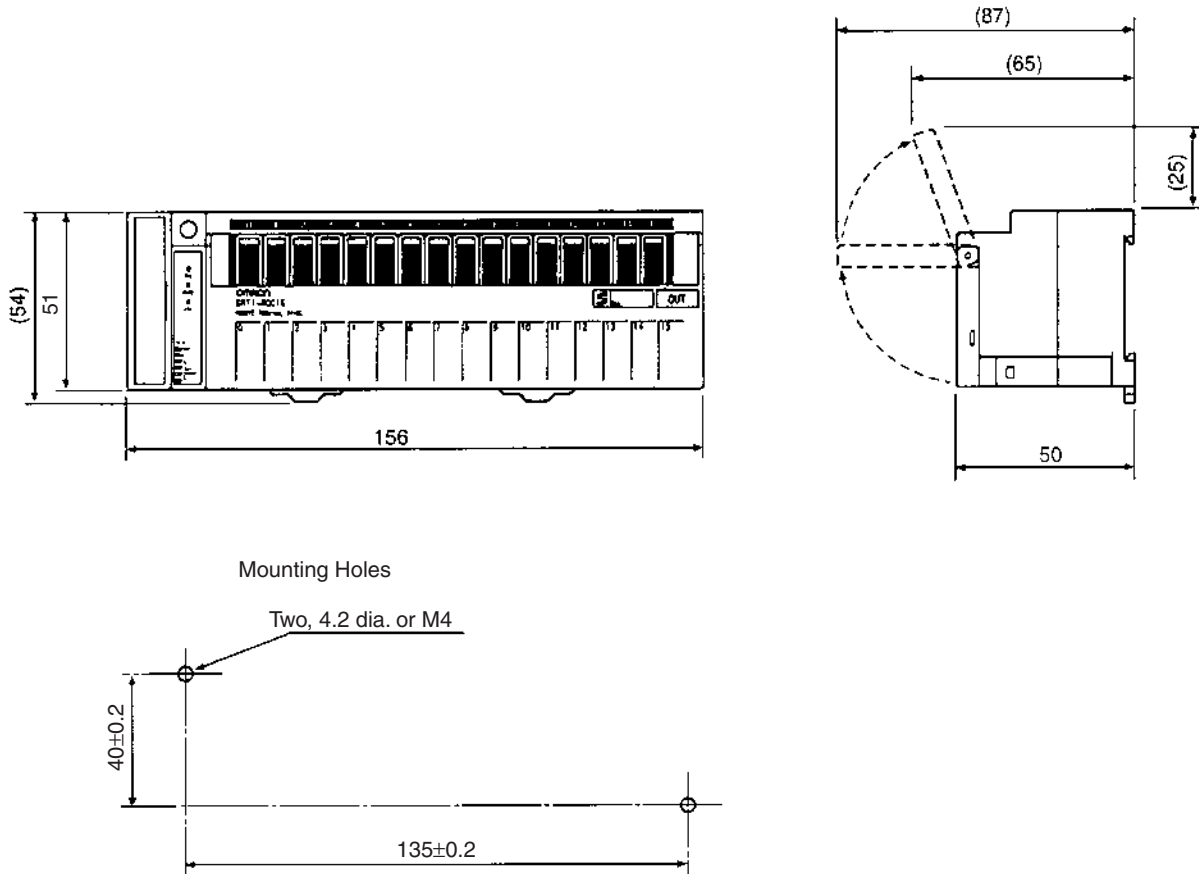

5-2 Connector Terminals

5-2-1 SRT2-VID□□□□ (-1) Connector Terminals with 8 Input or 16 Output Transistors

Specifications

The following tables show the ratings and input specifications for the SRT2-VID□□□□(-1).

Ratings

Item	Specification
Models	SRT2-VID08S SRT2-VID08S-1 SRT2-VID16ML SRT2-VID16ML-1
Input points/Connection type	SRT2-VID08S: 8 points (NPN)/ Cable connector input SRT2-VID08S-1: 8 points (PNP)/ Cable connector input SRT2-VID16ML: 16 points (NPN)/ MIL connector input SRT2-VID16ML-1: 16 points (PNP)/ MIL connector input

Item		Specification
Connection	Input	SRT2-VID08S (-1): By XS8A-0441 Connector or XS8A-0442 Connector (both sold separately) SRT2-VID16ML (-1): By XG4M-2030-T MIL Connector (sold separately), or G79-050C, G79-025C, G79-150C and G79-125C MIL-compatible Cables (all sold separately)
	Communications power	By communications connector (included as standard)
	I/O power	
Power supply type		Multiple power supplies
Communications power supply voltage		14 to 26.4 V DC (Power can be supplied from the communications cable)
I/O power supply voltage		20.4 to 26.4 V DC (24 V DC ^{+10%} / _{-15%})
I/O power supply current		Cable connector: 2.4 A max. MIL connector: 2.0 A max.
Current consumption (See note.)		Communications power: 50 mA max. at 24 V DC
Noise immunity		±1.5 kVp-p with a pulse width of 0.1 to 1 μs and a rise time of 1 ns (tested with impulse noise simulator)
Vibration resistance		10 to 150 Hz, 1.0-mm double amplitude or 70 m/s ²
Shock resistance		200 m/s ²
Dielectric strength		500 V AC (between insulated circuits)
Ambient temperature		Operating: -10 to 55°C (with no icing or condensation) Storage: -25 to 65°C (with no icing or condensation)
Ambient humidity		Operating: 25% to 85% (with no condensation) Storage: 25% to 85% (with no condensation)
Operating environment		No corrosive gases
Standard accessory		1 communications connector Note: Mounting Brackets A (SRT2-ATT01) and B (SRT2-ATT02) are sold separately.
Mounting strength		Pulling: 100 N in each direction. (When mounted with Mounting Bracket B: 40 N)
Terminal strength		Pulling: As stated below. Communications connector: 100 N Cable connector: 40 N MIL connector: 100 N Tightening: 0.25 N • m (for communications connector)
Node number settings		The node number is set on a DIP switch. (Set the node number before turning ON the Slave.)
Weight		Approx. 75 g

Note This is the current consumption when all the maximum simultaneous input points are ON, excluding the current consumption of external sensors.

Input Specifications

Item	VID08S/VID08S-1	VID16ML/VID16ML-1
Input current	6 mA max./point at 24 V DC 3 mA min./point at 17 V DC	
ON delay time	1.5 ms max.	
OFF delay time	1.5 ms max.	
ON voltage	VID08S/VID16ML: 15 V DC min. (between each input terminal and V) VID08S-1/VID16ML-1: 15 V DC min. (between each input terminal and G)	
OFF voltage	VID08S/VID16ML: 5 V DC max. (between each input terminal and V) VID08S-1/VID16ML-1: 5 V DC max. (between each input terminal and G)	
OFF current	1 mA max.	
Insulation method	Photocoupler	
Max. simultaneous input points	8 points	12 points
Number of circuits	8 points/single common circuit	16 points/single common circuit

Simultaneous Input Points and Installation Spacing

For Connector Terminals with transistor inputs, the ambient operating temperature places a limit on the maximum number of points that can be turned ON simultaneously. In addition, when installing Connector Terminals, care must be taken to provide adequate space between them to prevent overheating.

As shown in the graphs below, the spacing of Connector Terminals varies according to the Connector Terminal type, the ambient operating temperature, and the number of simultaneous input points. Make the distance between Connector Terminals greater than that shown in the graphs.

For example, if SRT2-VID16ML Connector Terminals are to be mounted vertically where the ambient operating temperature will be 55°C and the maximum number of simultaneous input points will be 8, the spacing of Connector Terminals should be at least 10 mm.

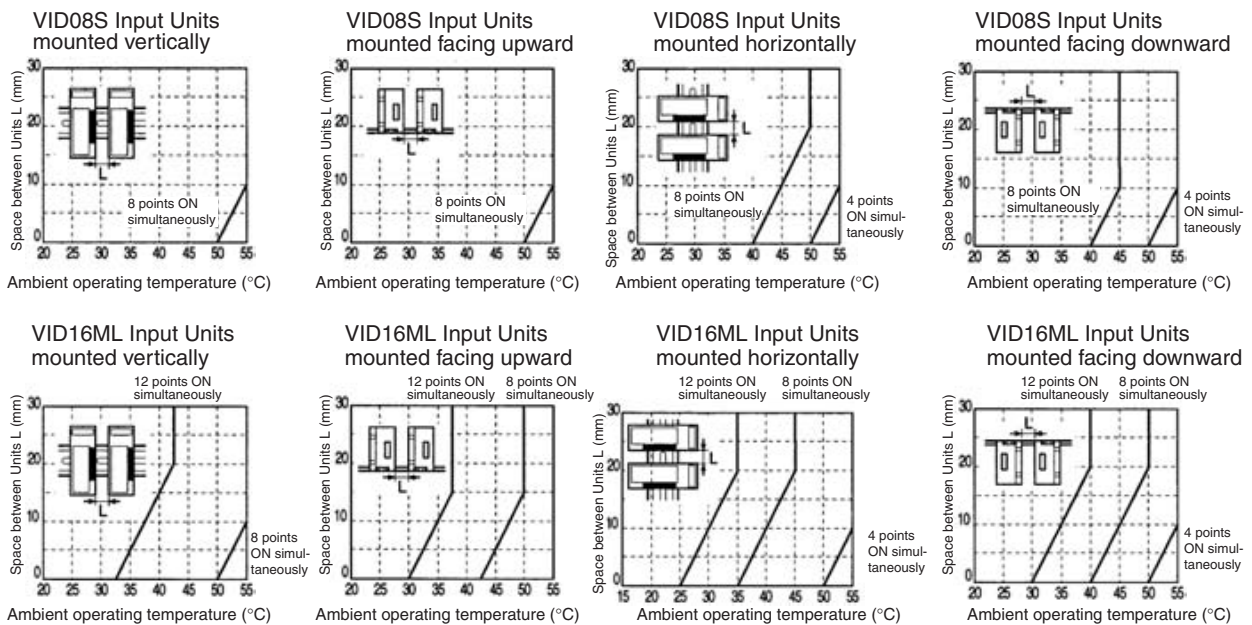

Slave Components

The following diagram shows the main components of the SRT2-VID□□□□ (-□) Connector Terminals with transistor inputs. The functions of these components are described below.

Models with Sensor Connectors

SRT2-VID08S/VID08S-1

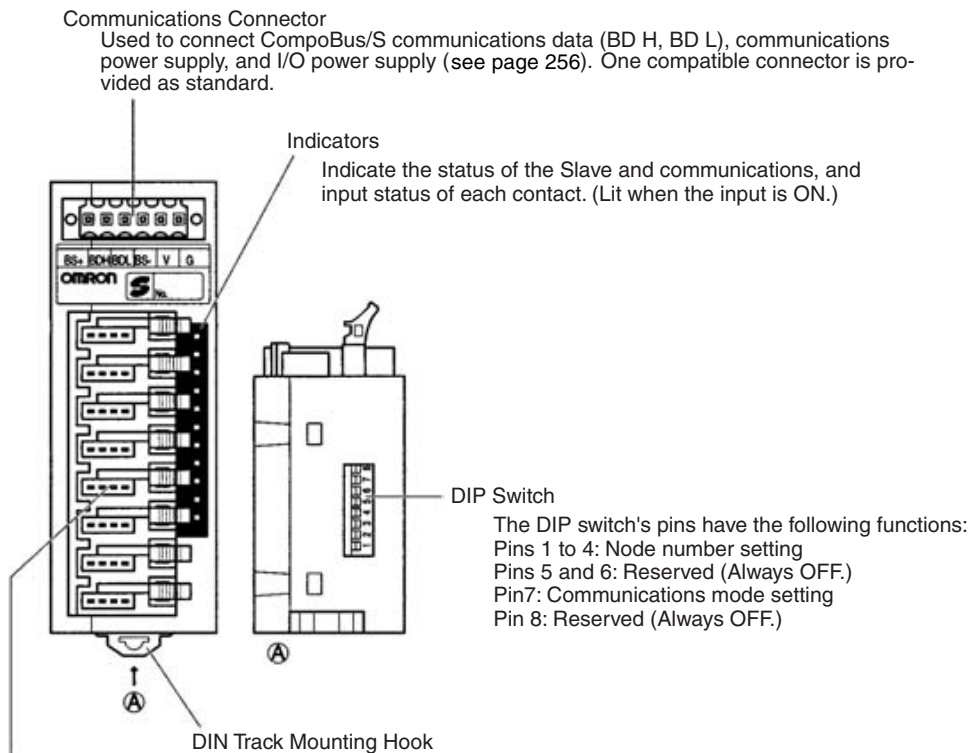

Communications Connector
Used to connect CompoBus/S communications data (BD H, BD L), communications power supply, and I/O power supply (see page 256). One compatible connector is provided as standard.

Indicators
Indicate the status of the Slave and communications, and input status of each contact. (Lit when the input is ON.)

DIP Switch
The DIP switch's pins have the following functions:
Pins 1 to 4: Node number setting
Pins 5 and 6: Reserved (Always OFF.)
Pin7: Communications mode setting
Pin 8: Reserved (Always OFF.)

Input Connector (Cable Connector)
Connect 8 inputs with cable connector (see page 67).

The XS8A-0441 Cable Connector (compatible wire size: 0.3 to 0.5 mm²) and the XS8A-0442 Cable Connector (compatible wire size: 0.14 to 0.2 mm²) are sold separately.

Models with MIL Connectors

SRT2-VID16ML/VID16ML-1

Communications Connector

Used to connect CompoBus/S communications data (BD H, BD L), communications power supply and I/O power supply (see page 256).
One compatible connector is provided as standard.

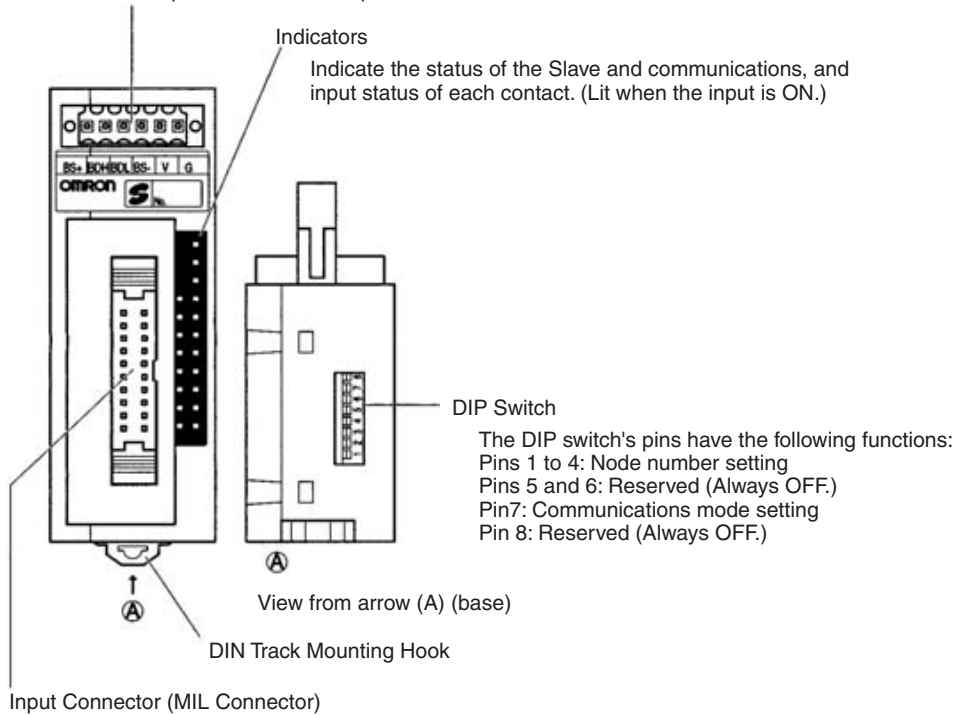

Input Connector (MIL Connector)

Connect 16 inputs with MIL Connector (see page 258).
XG4M-2030-T MIL Connector and compatible cable are sold separately.

Indicators

The following table shows the meaning of the indicators.

Indicator	Status	Meaning
PWR (green)	ON	The communications power supply is ON.
	OFF	The communications power supply is OFF.
COMM (yellow)	ON	Normal communications
	OFF	A communications error has occurred or the Unit is in standby status.
ERR (red)	ON	A communications error has occurred.
	OFF	Normal communications or the Unit is in standby status.
0 to 7 (8 inputs)	ON	The corresponding input is ON.
0 to 15 (16 inputs)	OFF	The corresponding input is OFF or the Unit is in standby status.

DIP Switch

The DIP switch is located on the base of the Connector Terminal.

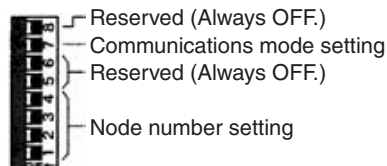

Note Always turn OFF the Slave before changing DIP switch settings.

Node Number Settings

Set the node number with pins 1 through 4, as shown in the following table.

Node number	Pin 4 (8)	Pin 3 (4)	Pin 2 (2)	Pin 1 (1)
0	OFF	OFF	OFF	OFF
1	OFF	OFF	OFF	ON
2	OFF	OFF	ON	OFF
3	OFF	OFF	ON	ON
4	OFF	ON	OFF	OFF
5	OFF	ON	OFF	ON
6	OFF	ON	ON	OFF
7	OFF	ON	ON	ON
8	ON	OFF	OFF	OFF
9	ON	OFF	OFF	ON
10	ON	OFF	ON	OFF
11	ON	OFF	ON	ON
12	ON	ON	OFF	OFF
13	ON	ON	OFF	ON
14	ON	ON	ON	OFF
15	ON	ON	ON	ON

Communications Mode Settings

The following communications modes are set with pin 7 as shown below.

Pin 7	Communica- tions mode	Communica- tions distance	Communica- tions baud rate	Communica- tions cycle time
OFF	High-speed Com- munications Mode	100 m max.	750 kbps	0.5 or 0.8 ms
ON	Long-distance Communications Mode	500 m max.	93.75 kbps	4.0 or 6.0 ms

Note Make sure that the communications mode of the Slave is the same as that of the Master Unit. If the communications are not the same, normal communications with the Master Unit will not be possible. The operating status of the Slave can be verified with LED indicators. Refer to *6-5-1 Indicators* for details.

Internal Circuits

The following diagram shows the internal circuits for the SRT2-VID08S.

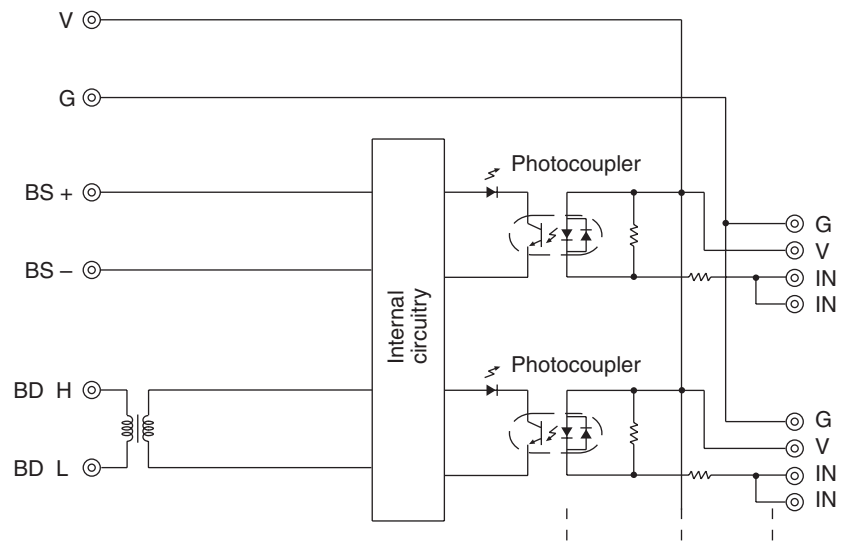

The following diagram shows the internal circuits for the SRT2-VID08S-1.

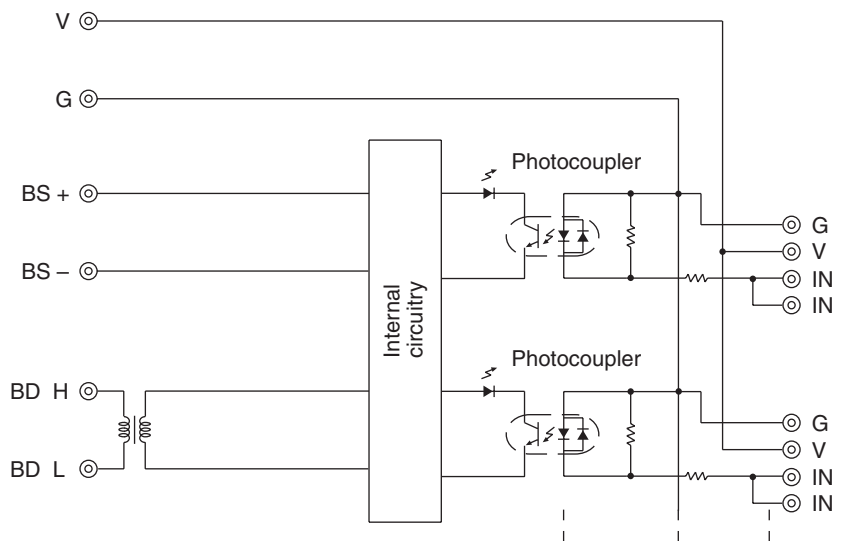

The following diagram shows the internal circuits for the SRT2-VID16ML.

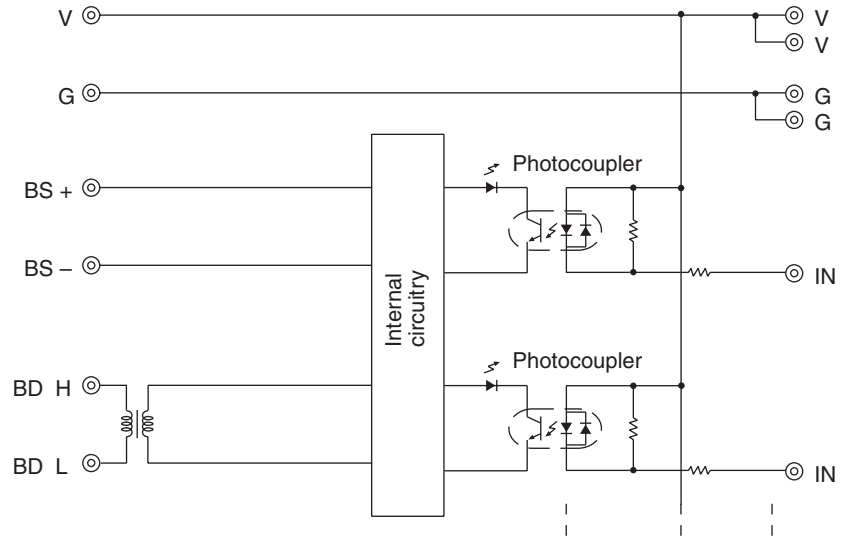

The following diagram shows the internal circuits for the SRT2-VID16ML-1

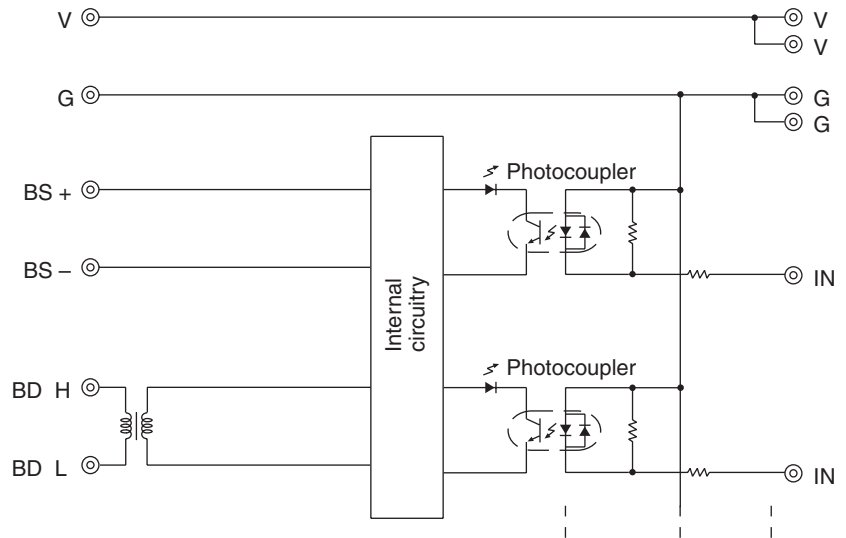

Wiring

• Communications Connector Pin Arrangement

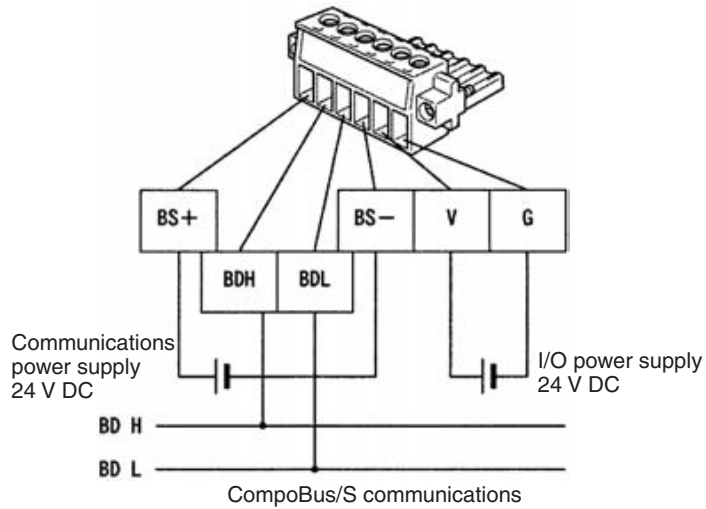

The communications connector (provided as standard) can be ordered as the following product:
 BL3.5/6F (product no. 160668) manufactured by Weidmuller Co., Ltd.

- Note** 1. OMRON recommends the following products manufactured by Weidmuller Co., Ltd. for use as crimp terminals.

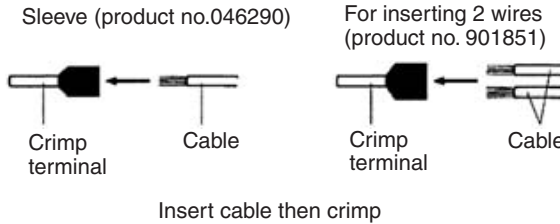

2. The following special tool is available:
 Crimper PZ1.5 (product no. 900599) manufactured by Weidmuller Co., Ltd.

• Cable Connector Pin Arrangement (SRT2-VID08S and SRT2-VID08S-1)

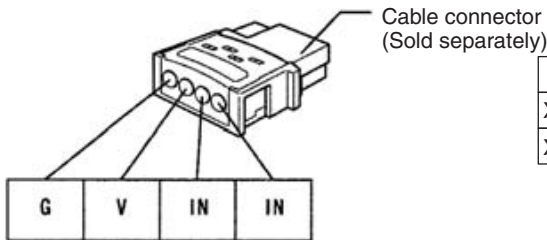

Cable Connector	
Model	Compatible cable conductor size
XS8A-0441	0.3 to 0.5 mm ²
XS8A-0442	0.14 to 0.2 mm ²

Note The XS8A-0441 and XS8A-0442 Connectors are not provided with the Unit. The Connectors must be ordered separately.

MIL Connector Pin Arrangement (SRT2-VID16ML and SRT2-VID16ML-1)

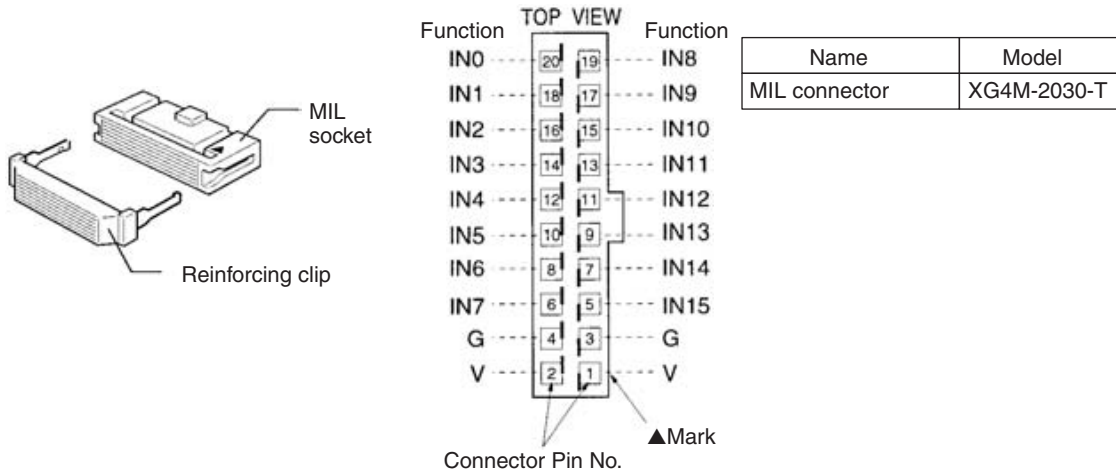

Note The XG4M-2030-T MIL Connector is not provided as standard and must be ordered separately.

Terminal Arrangement and Wiring Method

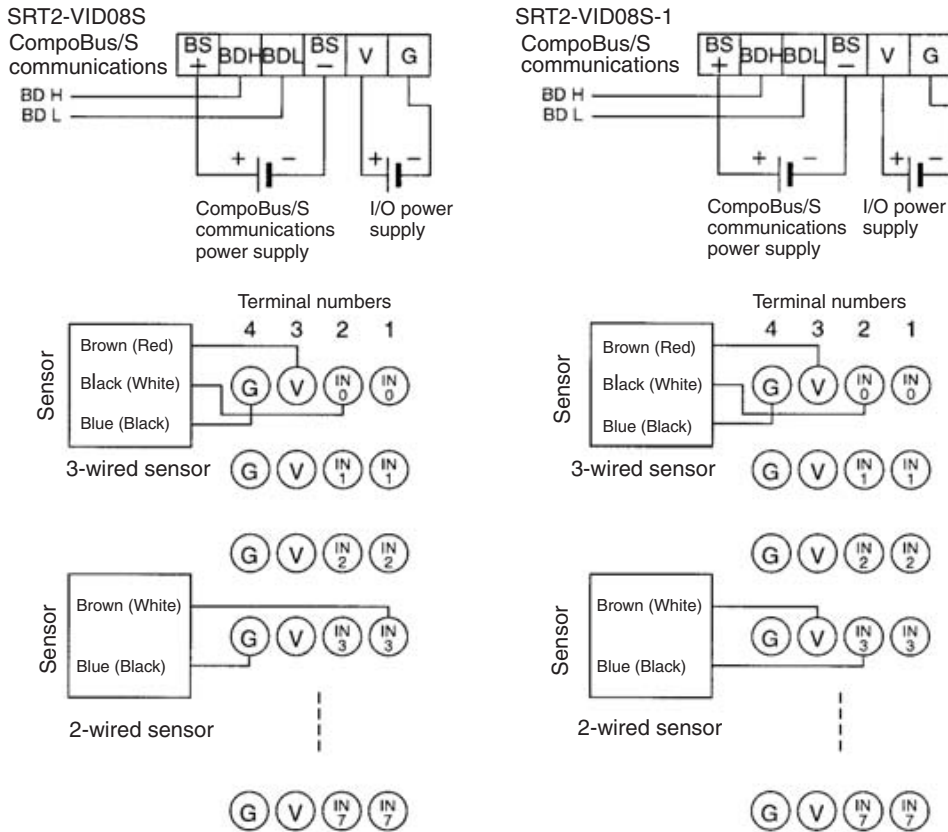

Note 1. The V terminals are all connected internally, as are the G terminals. When providing I/O power from a communications connector, power can be provided to sensors from the V and G terminals of the corresponding cable connector.

- In accordance with the changes in the standards for photoelectric sensors and proximity sensors, wire colors have been changed. Colors in parentheses are the old wire colors.

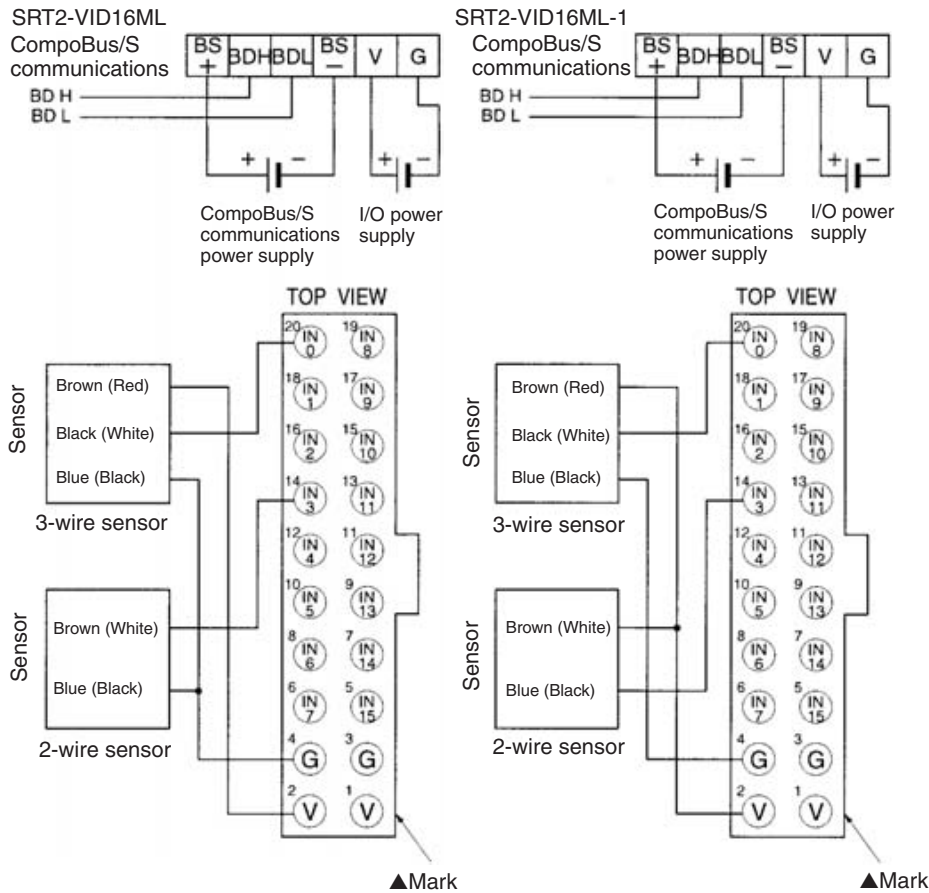

- Note**
- The V terminals are all connected internally, as are the G terminals. When providing I/O power from a communications connector, power can be provided to sensors from the V and G terminals of the MIL Connector.
 - In accordance with the changes in the standards for photoelectric sensors and proximity sensors, wire colors have been changed. Colors in parentheses are the old wire colors.

Compatible External Input Devices and Cables

Models with Sensor Connectors (SRT2-VID08S-1)

The XS8A-0441 and XS8A-0442 Connectors (sold separately) are used to connect to external input devices. Use the following flowchart to check the compatibility of external input devices and cables. Refer to *3-4-3 Cable Connector Wiring and Assembly* for details on the assembly, wiring, and installation of cable connectors.

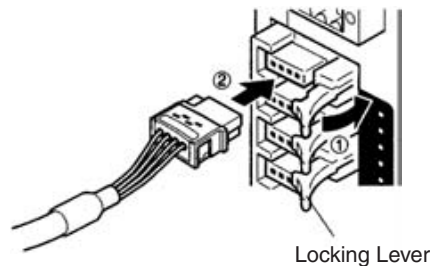

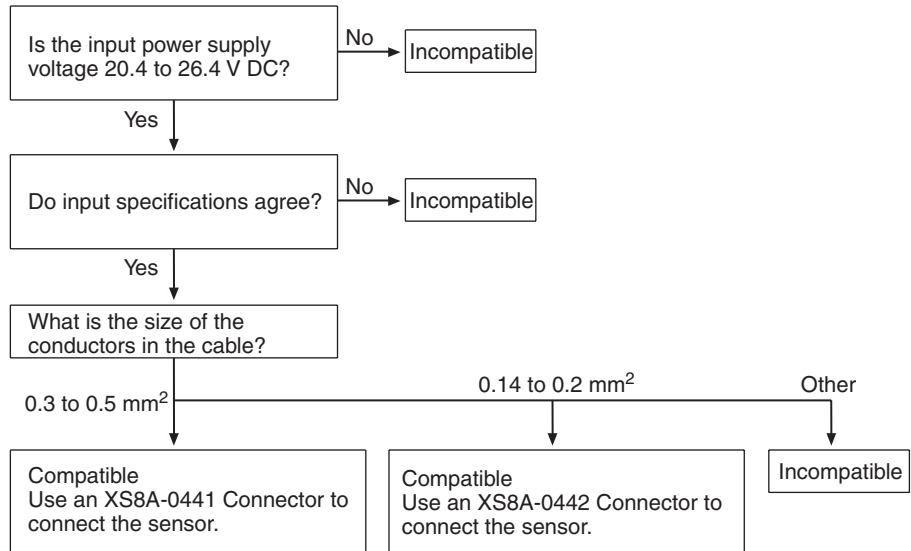

Note

1. The size of the sensor cable conductor is calculated as below.
Conductor description of sensor cable:

$$\begin{aligned} &\phi \text{ Outside diameter of cable (number of wires/wire diameter)} \\ &\text{conductor size (mm}^2\text{)} \\ &= (\text{wire diameter}/2)^2 \times \pi \times \text{number of wires} \end{aligned}$$

Example: E3S-A Sensor

$$\begin{aligned} &\phi 4 (18/0.12) \rightarrow \text{Conductor size (mm}^2\text{)} \\ &= (0.12/2)^2 \times 3.14 \times 18 = 0.20 \end{aligned}$$

Since the conductor size works out to be 0.2 mm², use XS8A-0442 Connector.

2. The XS8A-0441 and XS8A-0442 Connectors are not provided with the Unit. The Connectors must be ordered separately.

Models with MIL Connectors (SRT2-VID16ML-1)

The MIL Connector can be connected to external devices using either of the following methods.

- 1,2,3... 1. Using an XG4A-2030-T MIL Connector (sold separately) to Assemble Your Own Cable

For details, refer to *MIL Connector Wiring and Assembly* on page 258.

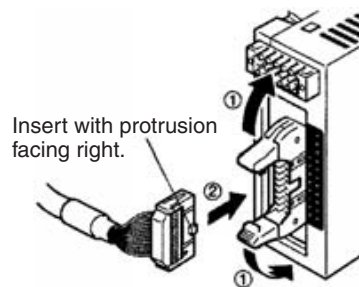

2. Connecting with OMRON Products Using an MIL-compatible Cable Manufactured by OMRON

MIL-compatible cable

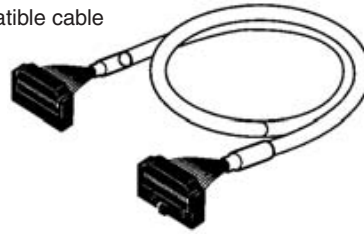

Straight power supply cable
G79-O50C (L = 500 mm)
G79-O25C (L = 250 mm)

Cross power supply cable
G79-I50C (L = 500 mm)
G79-I25C (L = 250 mm)

Wiring diagram

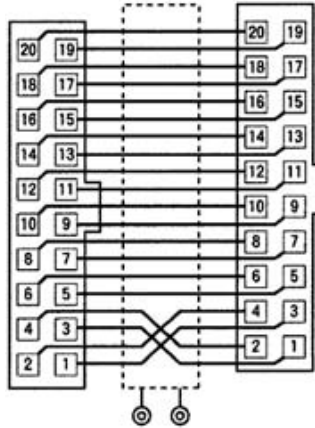

Wiring diagram

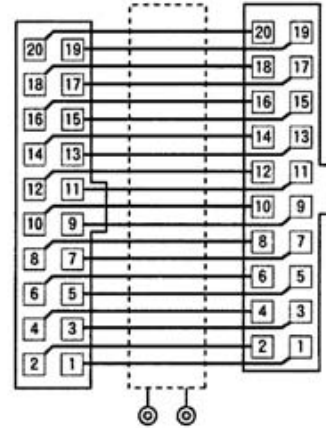

Compatible OMRON Products Used with MIL Connectors

Slave model number	Connecting cable	Compatible product
SRT2-VID16ML	G79-150C (50 cm) G79-125C (25 cm)	G7TC-IA16/ID16
	G79-050C (50 cm) G79-025C (25 cm)	XW2D-20G6 XW2B-20G5/20G4
SRT2-VID16ML-1	G79-050C (50 cm) G79-025C (25 cm)	XW2D-20G6 XW2B-20G5/20G4
		G7TC-OC16/08 G70D Series G70R-SOC08 G70A-ZOC16-3 and Relays XW2D-20G6 XW2B-20G5/20G4
SRT2-VOD16ML-1	G79-I50C (50 cm) G79-I25C (25 cm)	G7TC-OC16-1
	G79-050C (50 cm) G79-025C (25 cm)	G70D-SOC16-1/FOM16-1 G70A-ZOC16-4 and Relays XW2D-20G6 XW2B-20G5/20G4

Note MIL-compatible cables are not provided as standard and must be ordered separately.

Dimensions

- **Models with Sensor Connectors**

All dimensions are in mm.

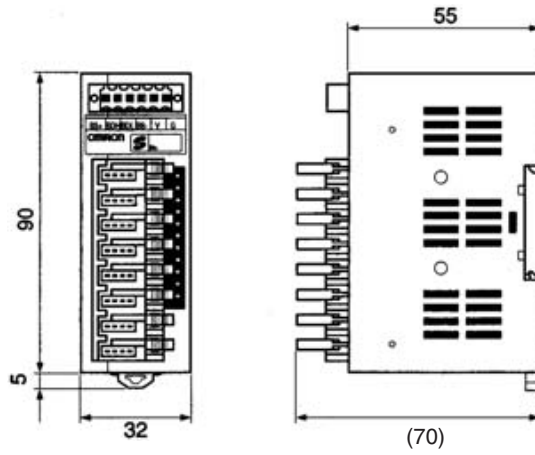

- **Models with MIL Connector**

All dimensions are in mm.

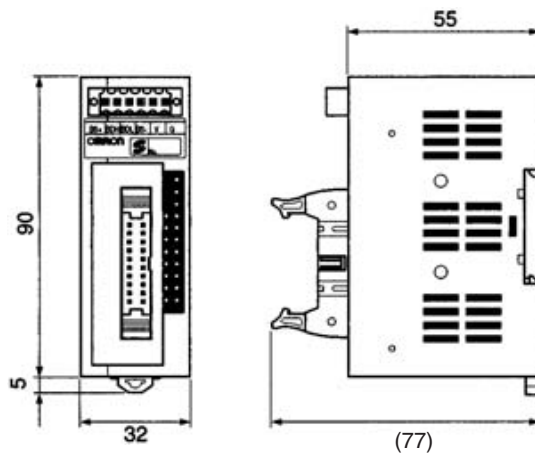

Wiring Dimensions

- **Models with Sensor Connector**

All dimensions are in mm.

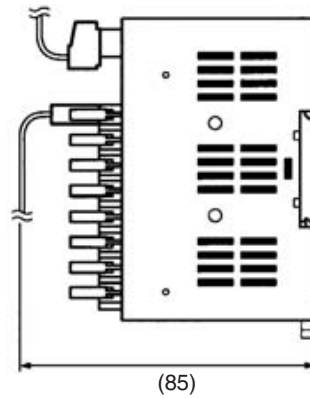

• Models with MIL Connector

All dimensions are in mm.

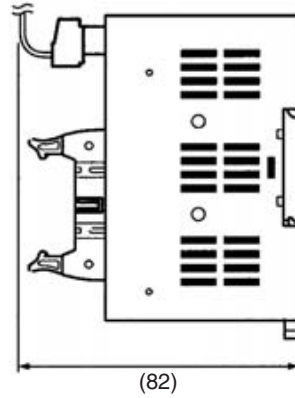

Mounting Methods

Connector Terminals can be mounted using any of methods 1 to 4 below.

1,2,3...

- 1. Mounting Directly to DIN Track (Mounting Brackets Not Required)

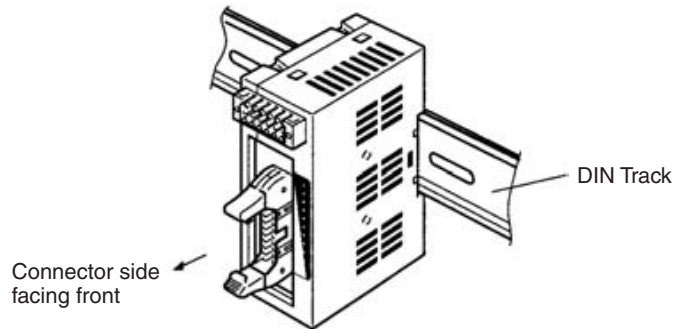

- a) Hook over the top of the DIN Track, then press the Connector Terminal against the DIN Track.

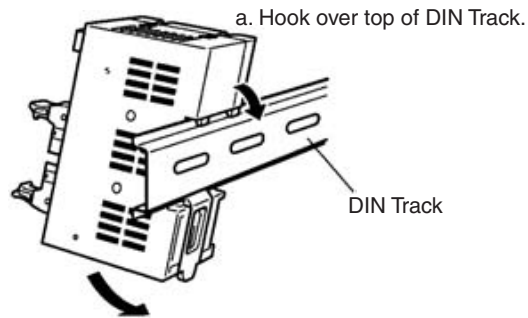

- b. The DIN Track Mounting Hook will engage automatically when the Connector Terminal is pressed against the DIN Track.

b) Secure both sides of the Connector Terminal with two end plates.

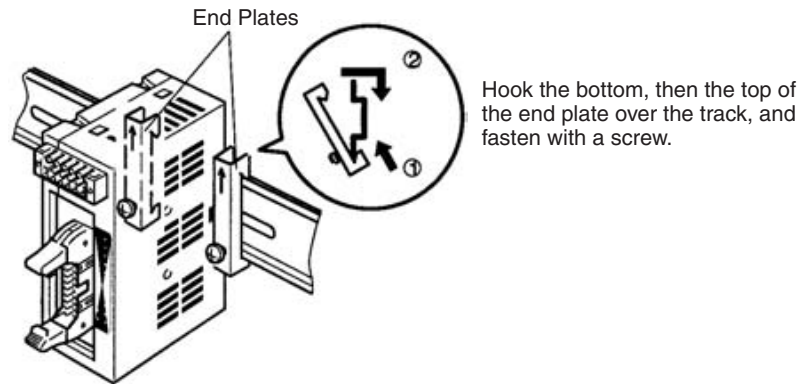

2. Mounting on DIN Track with Connector Side Facing Upward (Mounting Brackets A and B Required)

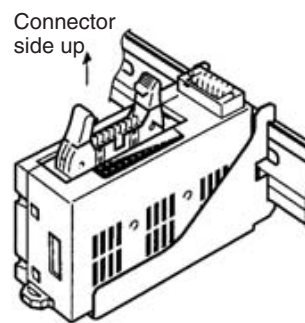

a) Secure Mounting Bracket A on the DIN Track with two Phillips screws.

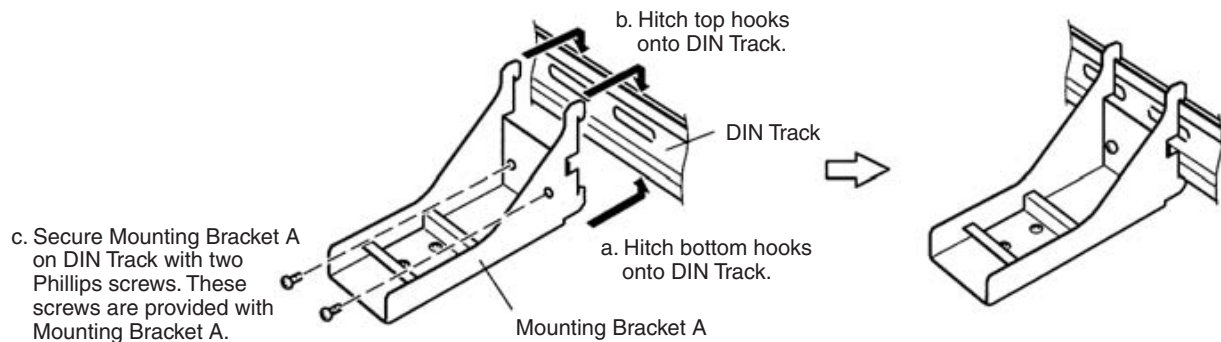

b) Press the Connector Terminal down into Mounting Bracket A.

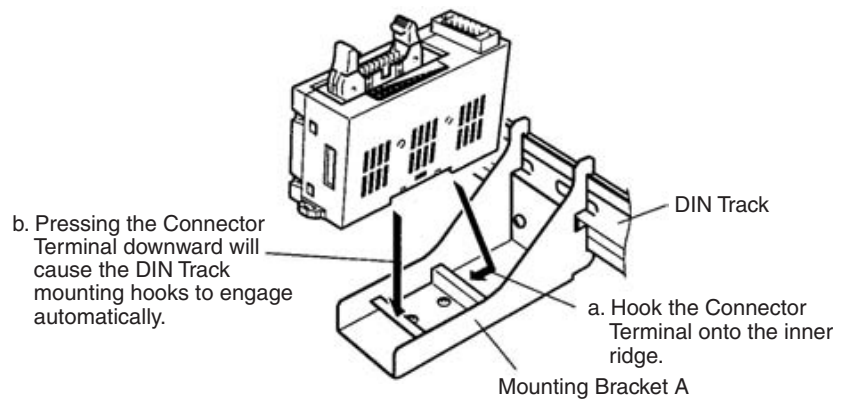

3. Mounting Perpendicularly to Wall or Panel (Mounting Bracket B Required)

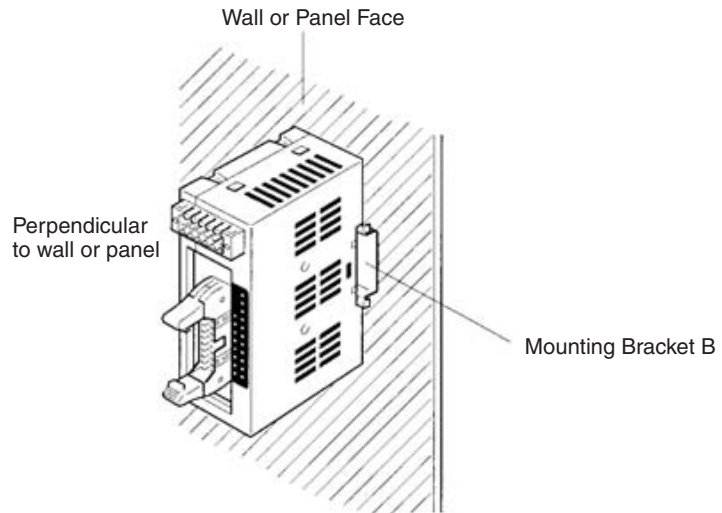

a) Attach Mounting Bracket B to the wall or panel with two Phillips screws.

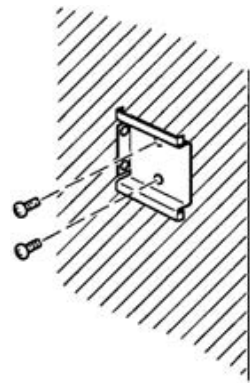

b) Using Mounting Bracket B in place of the DIN Track, attach the Connector Terminal to it as you would to the DIN Track directly.

4. Mounting Flat against Wall or Panel (Mounting Bracket B Required)

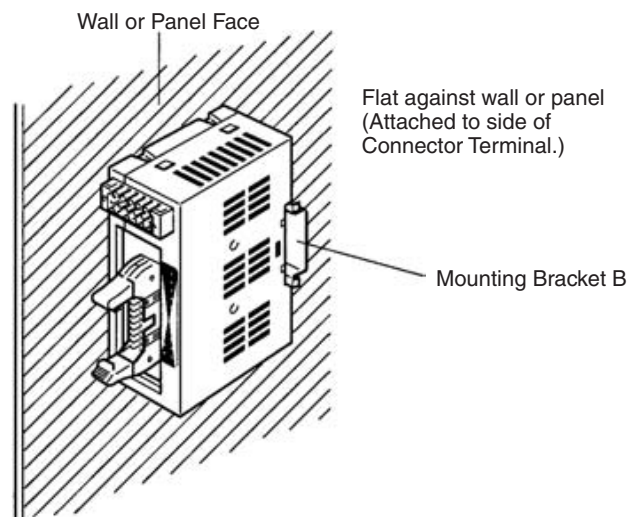

- a) Attach Mounting Bracket B perpendicularly to the wall or panel with two Phillips screws.

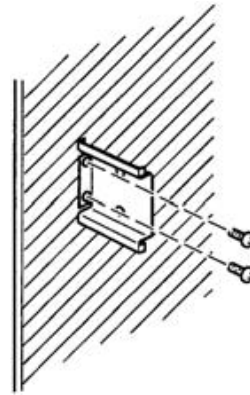

- b) Using Mounting Bracket B in place of the DIN Track, attach the Connector Terminal to it as you would to the DIN Track directly.

Mounting Bracket Dimensions

The following diagram shows the dimensions of Mounting Brackets A and B.

Mounting Bracket A (SRT2-ATT01)

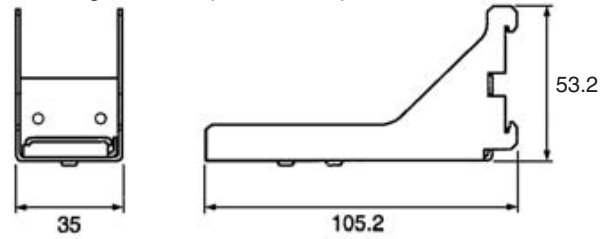

Mounting Bracket B (SRT2-ATT02)

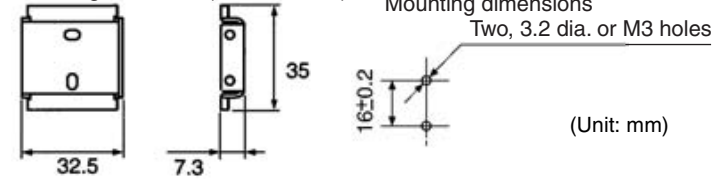

Mounting Methods

All dimensions are in mm.

1. Mounting Directly to DIN Track

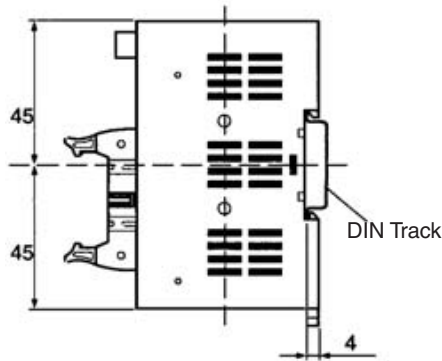

2. Mounting on DIN Track with Connector Side Facing Upward

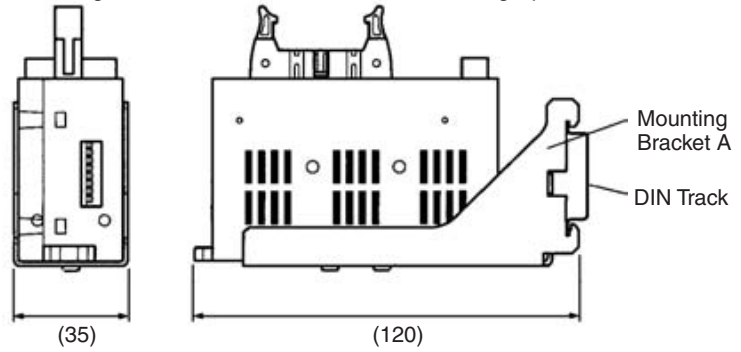

3. Mounting Perpendicular to Wall or Panel

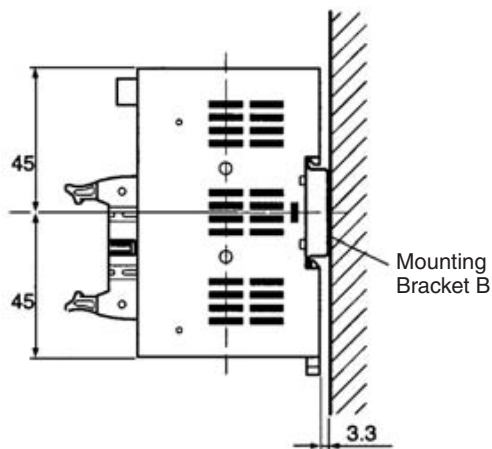

4. Mounting Flat against Wall or Panel

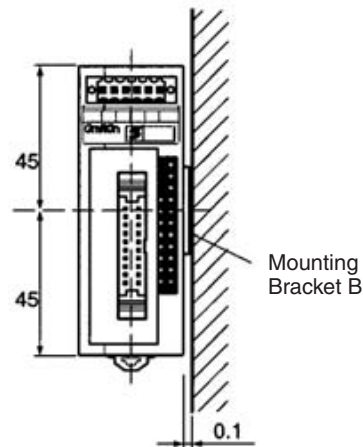

Distance from Duct

(Leave space of at least 20 mm above and below the Connector Terminal.)

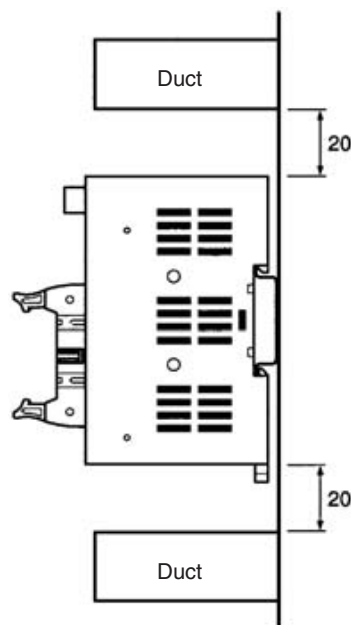

5-2-2 SRT2-VOD□□□□ (-1) Connector Terminals with 8 or 16 Transistor Outputs

Specifications

The following tables show the ratings and output specifications for the SRT2-VOD□□□□ (-1).

Ratings

Item		Specification
Models		SRT2-VOD08S SRT2-VOD08S-1 SRT2-VOD16ML SRT2-VOD16ML-1
Output points/Connection type		SRT2-VOD08S: 8 points (NPN)/Cable connector output SRT2-VOD08S-1: 8 points (PNP)/Cable connector output SRT2-VOD16ML: 16 points (NPN)/MIL connector output SRT2-VOD16ML-1: 16 points (PNP)/MIL connector output
Connection	Output	SRT2-VOD08S (-1): By XS8A-0441 or XS8A-0442 Connector (both sold separately) SRT2-VOD16ML (-1): By XG4M-2030-T MIL Connector (sold separately), or G79-050C, G79-025C, G79-150C and G79-125C MIL-compatible Cables (all sold separately)
	Communications power	By communications connector (included as standard)
	I/O power	
Power supply type		Multiple power supplies
Communications power supply voltage		14 to 26.4 V DC (Power can be supplied from the communications cable)
I/O power supply voltage		20.4 to 26.4 V DC (24 V DC $+10\%$ / -15%)
I/O power supply current		Cable connector: 2.4 A max. MIL connector: 2.0 A max.
Current consumption (See note.)		Communications power: 50 mA max. at 24 V DC
Noise immunity		± 1.5 kVp-p with a pulse width of 0.1 to 1 μ s and a rise time of 1 ns (tested with impulse noise simulator)
Vibration resistance		10 to 150 Hz, 1.0-mm double amplitude or 70 m/s ²
Shock resistance		200 m/s ²
Dielectric strength		500 V AC (between insulated circuits)
Ambient temperature		Operating: -10 to 55°C (with no icing or condensation) Storage: -25 to 65°C (with no icing or condensation)
Ambient humidity		Operating: 25% to 85% (with no condensation) Storage: 25% to 85% (with no condensation)
Operating environment		No corrosive gases
Standard accessory		1 communications connector Note: Mounting Brackets A (SRT2-ATT01) and B (SRT2-ATT02) are sold separately.
Mounting strength		Pulling: 100 N in each direction. (When mounted with Mounting Bracket B: 40 N)

Item	Specification
Terminal strength	Pulling: As stated below Communications connector: 100 N Cable connector: 40 N MIL Connector: 100 N Tightening: 0.25 N • m (for communications connector)
Node number settings	The node number is set on a DIP switch. (Set the node number before turning ON the Slave.)
Weight	Approx. 75 g

Note This is the current consumption when all the maximum simultaneous output points are ON, excluding the current consumption of external sensors.

Output Specifications

Item	VOD08S/VOD08S-1	VOD16ML/VOD16ML-1
Output current	0.3 A max./point	0.3 A max./point (2 A common) (See note.)
Residual voltage	VOD08S/VOD16ML: 1.2 V DC max. (between each input terminal and G) VOD08S-1/VOD16ML-1: 1.2 V DC max. (between each input terminal and V)	
Leakage current	VOD08S/VOD16ML: 0.1 mA max. VOD08S-1/VOD16ML-1: 0.1 mA max.	
ON delay time	0.5 ms max.	
OFF delay time	1.5 ms max.	
Insulation method	Photocoupler	
Number of circuits	8 points/single common circuit	16 points/single common circuit

Note When using the V and G terminals of the MIL connector, make sure that current does not exceed 1 A at each terminal.

Slave Components

The following diagram shows the main components of the SRT2-VOD□□□□ (-□) Connector Terminals with Transistor Outputs. The functions of these components are described below.

Models with Sensor Connectors
SRT2-VOD08S/VOD08S-1

Communications connector

Used to connect CompoBus/S communications data (BD H, BD L), communications power supply, and I/O power supply (see page 256).
One compatible connector is provided as standard.

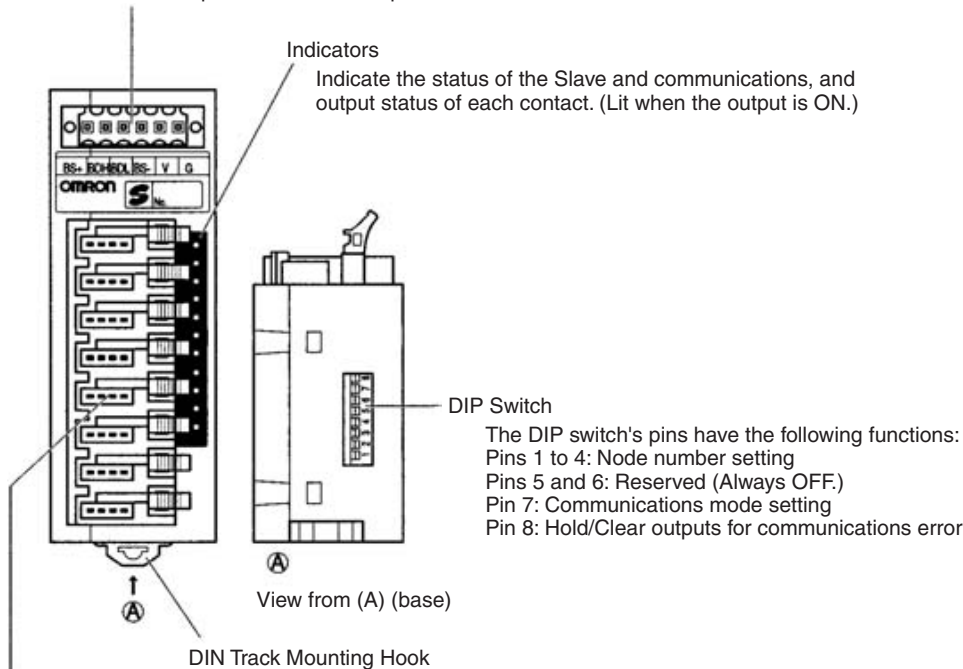

Indicators
Indicate the status of the Slave and communications, and output status of each contact. (Lit when the output is ON.)

DIP Switch
The DIP switch's pins have the following functions:
Pins 1 to 4: Node number setting
Pins 5 and 6: Reserved (Always OFF.)
Pin 7: Communications mode setting
Pin 8: Hold/Clear outputs for communications error

Output connector (cable connector)

Connect 8 outputs with cable connector (see page 67).
The XS8A-0441 Cable Connector (compatible conductor size: 0.3 to 0.5 mm²) and XS8A-0442 Cable Connector (compatible conductor size: 0.14 to 0.2 mm²) are sold separately.

Models with MIL Connectors
SRT2-VOD16ML/VOD16ML-1

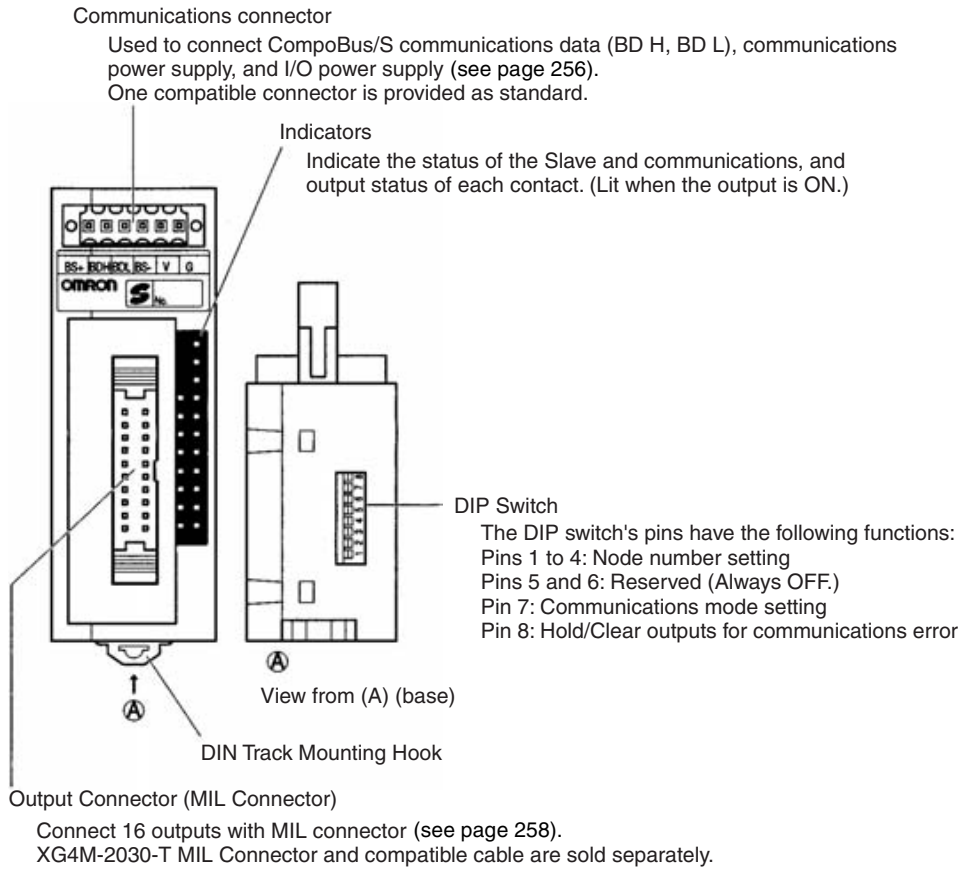

Indicators

The following table shows the meaning of the indicators.

Indicator	Status	Meaning
PWR (green)	ON	The communications power supply is ON.
	OFF	The communications power supply is OFF.
COMM (yellow)	ON	Normal communications
	OFF	A communications error has occurred or the Unit is in standby status.
ERR (red)	ON	A communications error has occurred.
	OFF	Normal communications or the Unit is in standby status.
0 to 7 (8 outputs) 0 to 15 (16 outputs)	ON	The corresponding output is ON.
	OFF	The corresponding output is OFF or the Unit is in standby status.

DIP Switch

The DIP switch is located on the base of the Connector Terminal.

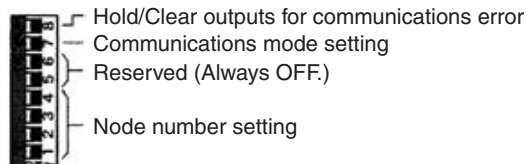

Note Always turn OFF the Slave before changing DIP switch settings.

Node Number Settings

Set the node number with pins 1 through 4, as shown in the following table.

Node number	Pin 4 (8)	Pin 3 (4)	Pin 2 (2)	Pin 1 (1)
0	OFF	OFF	OFF	OFF
1	OFF	OFF	OFF	ON
2	OFF	OFF	ON	OFF
3	OFF	OFF	ON	ON
4	OFF	ON	OFF	OFF
5	OFF	ON	OFF	ON
6	OFF	ON	ON	OFF
7	OFF	ON	ON	ON
8	ON	OFF	OFF	OFF
9	ON	OFF	OFF	ON
10	ON	OFF	ON	OFF
11	ON	OFF	ON	ON
12	ON	ON	OFF	OFF
13	ON	ON	OFF	ON
14	ON	ON	ON	OFF
15	ON	ON	ON	ON

Communications Mode Settings

The following communications modes are set with pin 7.

Pin 7	Communica- tions mode	Communica- tions distance	Communica- tions baud rate	Communica- tions cycle time
OFF	High-speed Com- munications Mode	100 m max.	750 kbps	0.5 or 0.8 ms
ON	Long-distance Communications Mode	500 m max.	93.75 kbps	4.0 or 6.0 ms

Note Make sure that the communications mode of the Slave is the same as that of the Master Unit. If the communications modes are not the same, normal communications with the Master Unit will not be possible. The operating status of the Slave can be verified with LED indicators. Refer to *6-5-1 Indicators*.

Hold/Clear Outputs for Communications Error

Pin 8 is used to set the output data status when a communications error occurs, as shown in the following table.

Pin 8 (HOLD)	Setting
OFF	Clear output status
ON	Maintain output status

Internal Circuits

The following diagram shows the internal circuits for the SRT2-VOD08S.

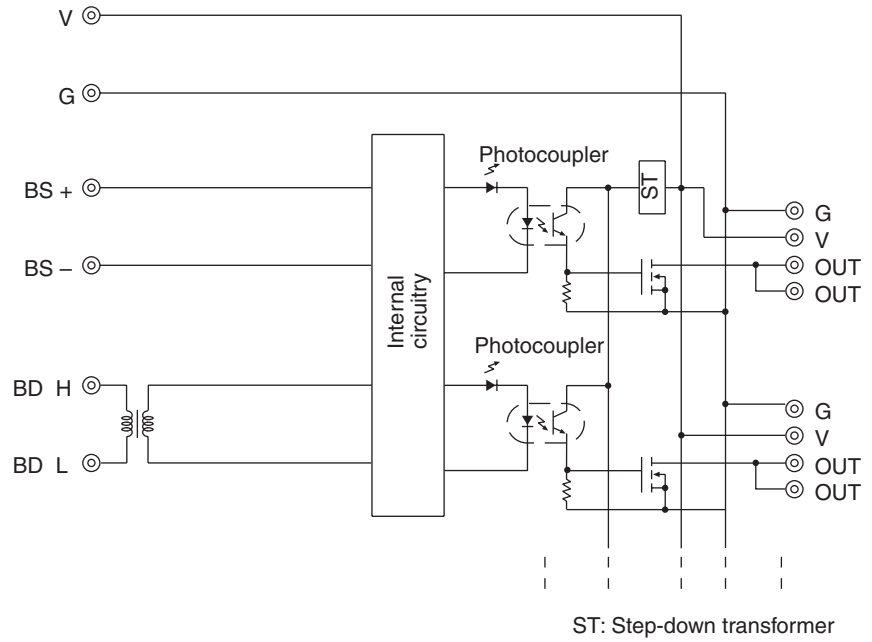

The following diagram shows the internal circuits for the SRT2-VOD08S-1.

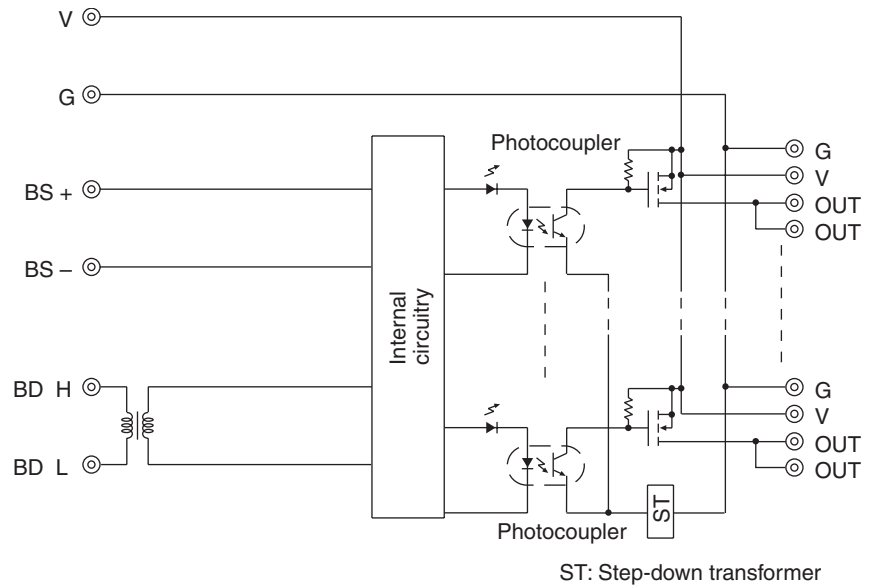

The following diagram shows the internal circuits for the SRT2-VOD16ML.

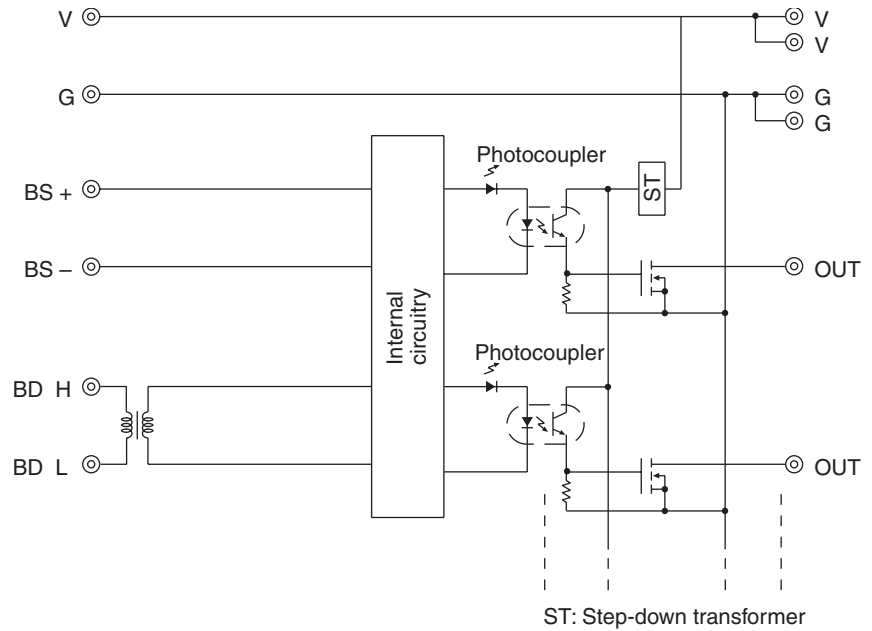

The following diagram shows the internal circuits for the SRT2-VOD16ML-1.

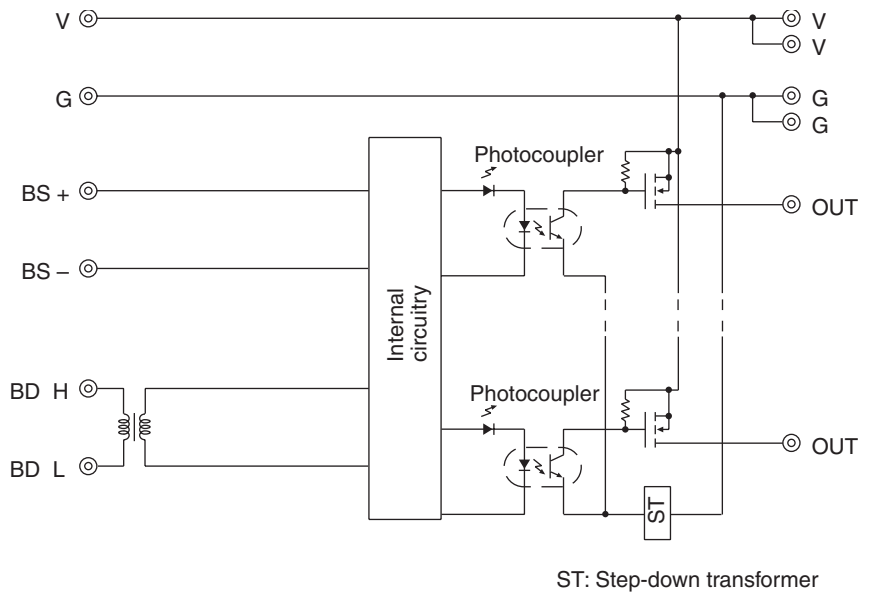

Wiring

• Communications Connector Pin Arrangement

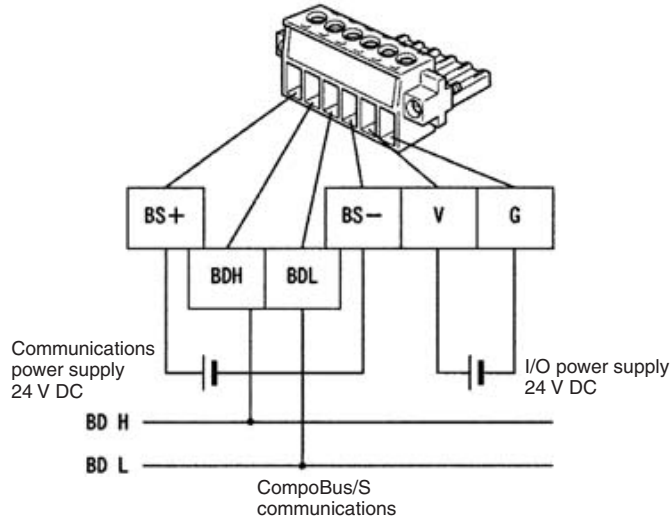

The communications connector (provided as standard) can be ordered as the following product:
BL3.5/6F (product no. 160668) manufactured by Weidmuller Co., Ltd.

- Note** 1. OMRON recommends the following products manufactured by Weidmuller Co., Ltd. for use as crimp terminals.

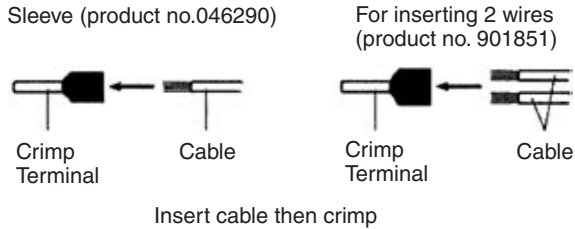

2. The following special tool is available:
Crimper PZ1.5 (product no. 900599) manufactured by Weidmuller Co., Ltd.

• Cable Connector Pin Arrangement

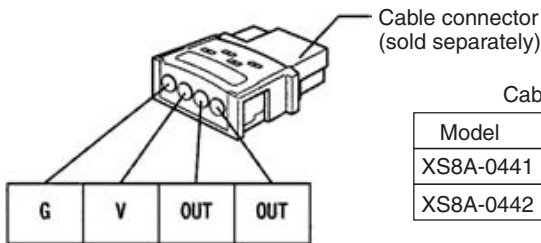

Cable connector	
Model	Compatible cable conductor size
XS8A-0441	0.3 to 0.5 mm ²
XS8A-0442	0.14 to 0.2 mm ²

Note The XS8A-0441 and XS8A-0442 Connectors are not provided with the Unit. The Connectors must be ordered separately.

MIL Connector Pin Arrangement (SRT2-VOD16ML and SRT2-VOD16ML-1)

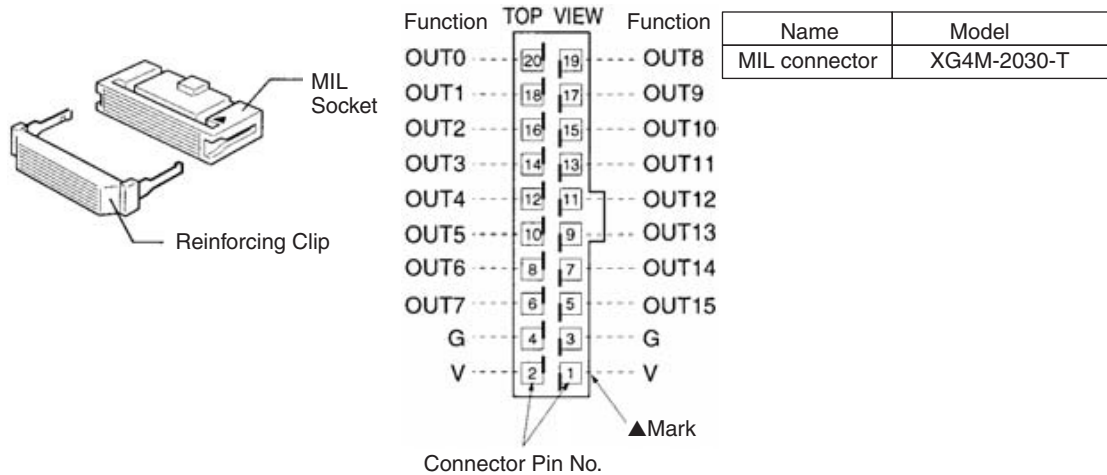

Note The XG4M-2030-T MIL Connector is not provided as standard and must be ordered separately.

Terminal Arrangement and Wiring Method

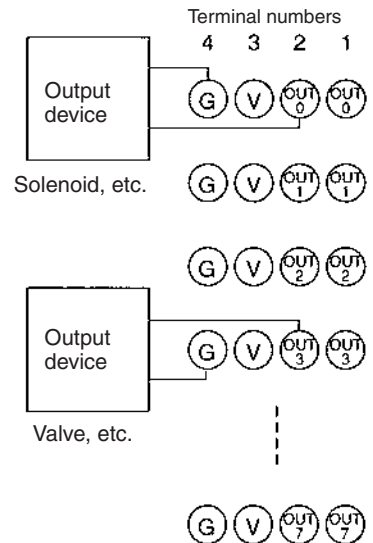
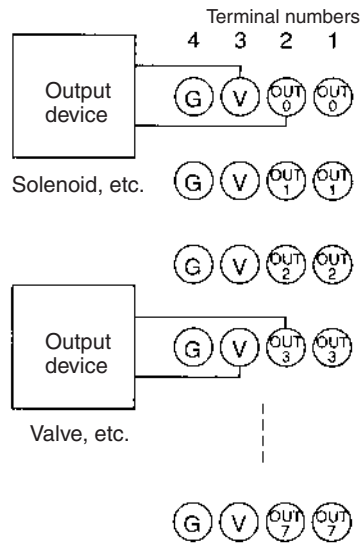
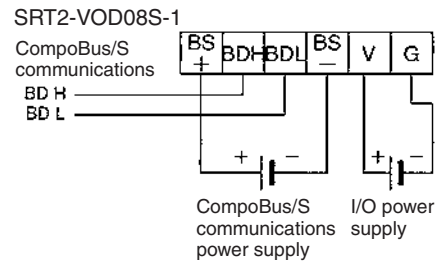
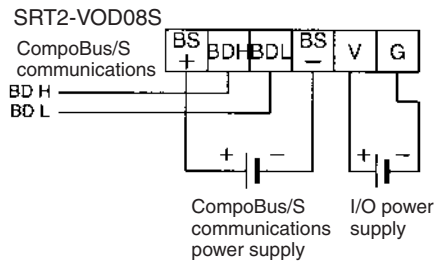

Note 1. The V terminals are all connected internally, as are the G terminals. When providing I/O power from a communications connector, power can be provided to output devices from the V and G terminals of the corresponding cable connector.

- When inductive loads such as solenoids and valves are used, either use loads with built-in diodes that absorb the back-electromotive force or connect a diode externally.

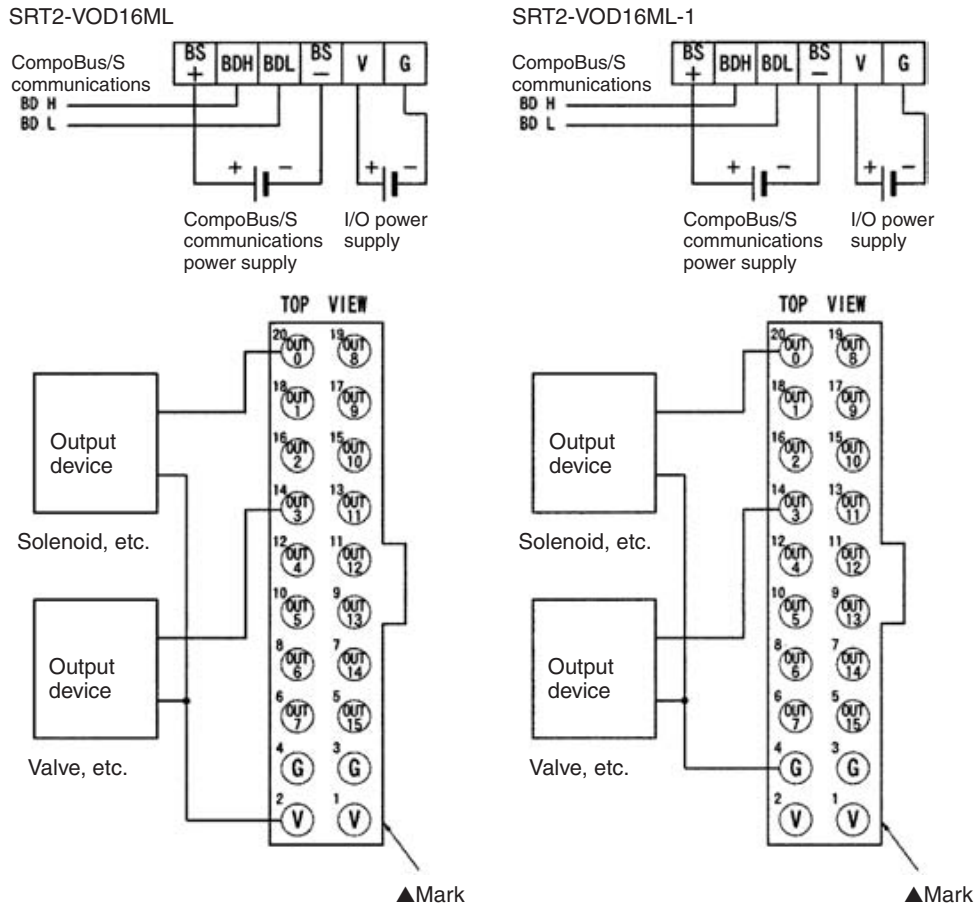

- Note**
- The V terminals are all connected internally, as are the G terminals. When providing I/O power from a communications connector, power can be provided to output devices from the V and G terminals of the MIL Connector.
 - When inductive loads such as solenoids and valves are used, either use loads with built-in diodes that absorb the back-electromotive force or connect a diode externally.

Compatible External Output Devices and Cables

Models with Sensor Connectors (SRT2-VOD08S-1)

The XS8A-0441 and XS8A-0442 Connectors (sold separately) are used to connect to external output devices. Use the following flowchart to check the compatibility of external output devices and cables. Refer to 3-4-3 *Cable Connector Wiring and Assembly* for details on the assembly, wiring, and installation of cable connectors.

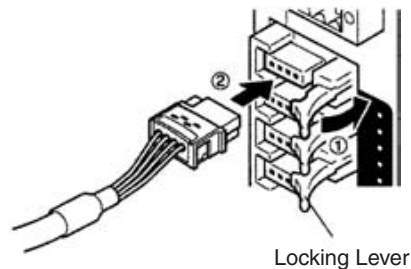

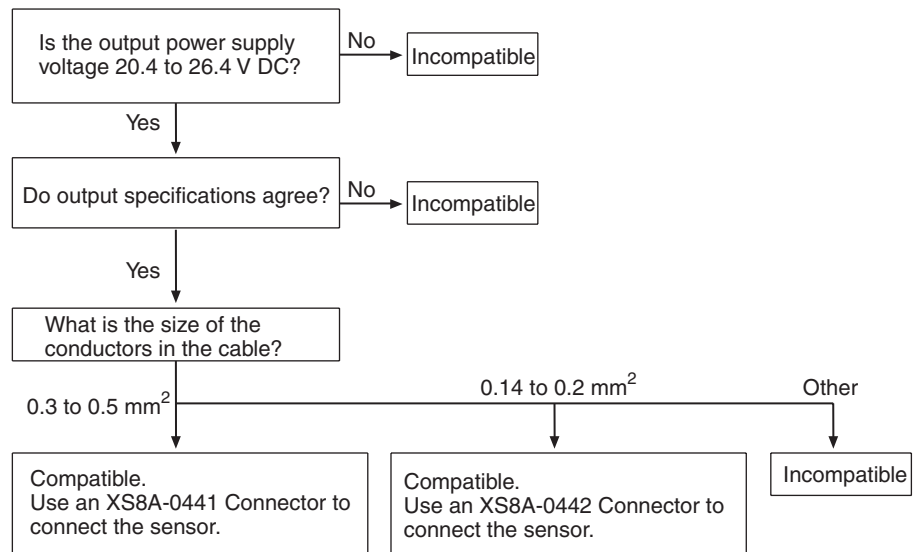

Note The XS8A-0441 and XS8A-0442 Connectors are not provided with the Unit. The Connectors must be ordered separately.

Models with MIL Connector (SRT2-VOD16ML-1)

The MIL Connector can be connected to external devices in either of the following methods.

- 1,2,3...** 1. Using an XG4A-2030-T MIL Connector (sold separately) to Assemble Your Own Cable
 For details, refer to *MIL Connector Wiring and Assembly* on page 258.

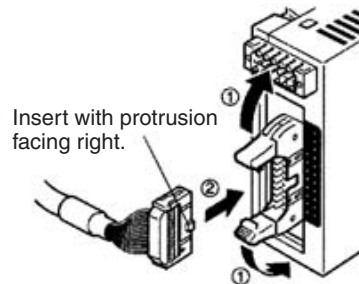

2. Connecting with OMRON Products Using an MIL-compatible Cable Manufactured by OMRON

MIL-compatible cable

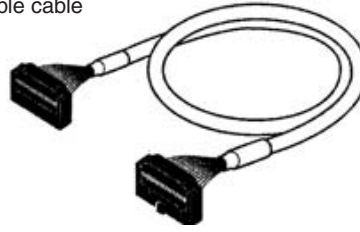

Straight power supply cable
G79-O50C (L = 500 mm)
G79-O25C (L = 250 mm)

Cross power supply cable
G79-I50C (L = 500 mm)
G79-I25C (L = 250 mm)

Wiring diagram

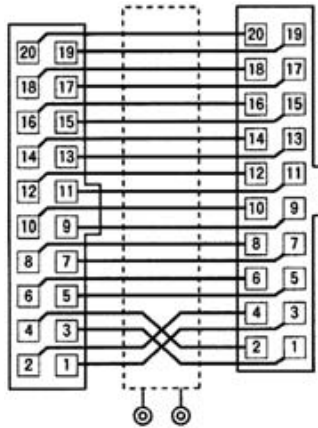

Wiring diagram

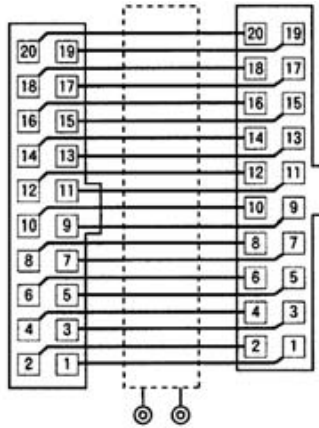

Compatible OMRON Products Used with MIL Connectors

Slave model number	Connecting cable	Compatible product
SRT2-VID16ML	G79-150C (50 cm) G79-125C (25 cm)	G7TC-IA16/ID16
	G79-050C (50 cm) G79-025C (25 cm)	XW2D-20G6 XW2B-20G5/20G4
SRT2-VID16ML-1	G79-050C (50 cm) G79-025C (25 cm)	XW2D-20G6 XW2B-20G5/20G4
		G7TC-OC16/08 G70D Series G70R-SOC08 G70A-ZOC16-3 and Relays XW2D-20G6 XW2B-20G5/20G4
SRT2-VOD16ML-1	G79-I50C (50 cm) G79-I25C (25 cm)	G7TC-OC16-1
	G79-050C (50 cm) G79-025C (25 cm)	G70D-SOC16-1/FOM16-1 G70A-ZOC16-4 and Relays XW2D-20G6 XW2B-20G5/20G4

Note MIL-compatible cables are not provided as standard and must be ordered separately.

Dimensions

• Models with Sensor Connectors

All dimensions are in mm.

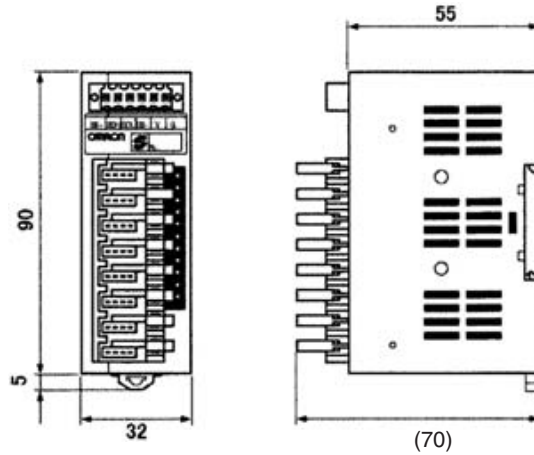

• Models with MIL Connectors

All dimensions are in mm.

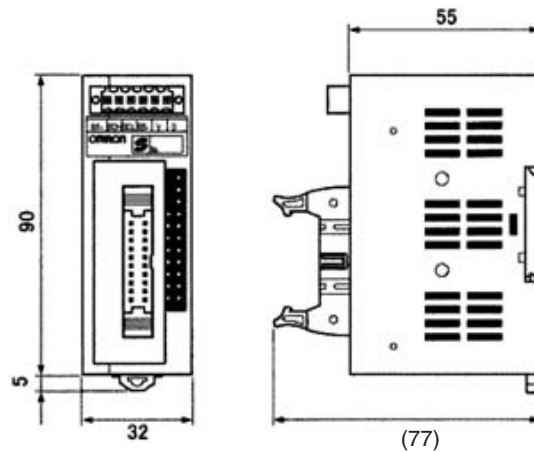

Note For details on wiring dimensions, installation methods, Mounting Bracket dimensions, and mounting methods, refer to 5-2-1 SRT2-VID□□□□ (-1) Connector Terminals with 8 Input or 16 Output Transistors.

5-2-3 SRT2-ID32ML (-1) Connector Terminals with 32 Transistor Inputs

Specifications

The following tables show the ratings and input specifications for the SRT2-ID32ML (-1).

Ratings

Item	Specification
Models	SRT2-ID32ML, SRT2-ID32ML-1
Input points/Connection type	SRT2-ID32ML: 32 points (NPN)/MIL connector input SRT2-ID32ML-1: 32 points (PNP)/MIL connector input
Connection	Communications power: By communications connector (included as standard) Input: MIL connector or MIL-compatible Cables (both sold separately) (see page 233) I/O power: MIL connector
Power supply type	Multiple power supplies

Item	Specification
Communications power supply voltage	14 to 26.4 V DC (Power can be supplied from the communications cable)
I/O power supply voltage	20.4 to 26.4 V DC (24 V DC $+10\%/_{-15\%}$)
Current consumption (See note.)	Communications power: 50 mA max. at 24 V DC
Noise immunity	1.5 kVp-p with a pulse width of 0.1 to 1 μ s and a rise time of 1 ns (tested with impulse noise simulator)
Vibration resistance	10 to 150 Hz, 0.7-mm double amplitude or 50 m/s ²
Shock resistance	150 m/s ²
Dielectric strength	500 V AC (between insulated circuits)
Ambient temperature	Operating: -10 to 55°C (with no icing or condensation) Storage: -25 to 65°C (with no icing or condensation)
Ambient humidity	Operating: 25% to 85% (with no condensation) Storage: 25% to 85% (with no condensation)
Operating environment	No corrosive gases
Standard accessory	1 communications connector Note Mounting Bracket B (SRT2-ATT02) is sold separately
Mounting strength	50 N
Terminal strength	Pulling: As stated below Communications connector: 30 N MIL connector: 30 N
Tightening torque	Communications connector: 0.25 to 0.3 N·m
Node number settings	The node number is set on a DIP switch. (Set the node number before turning ON the Slave.)
Weight	Approx. 100 g max.

Note This is the current consumption when all the maximum simultaneous input points are ON, excluding the current consumption of external sensors.

Input Specifications

Item	Specification
Input current	6 mA max./point at 24 V DC 3 mA min./point at 17 V DC
ON delay time	1.5 ms max.
OFF delay time	1.5 ms max.
ON voltage	ID32MIL: 17 V DC min. (between each input terminal and V) ID32ML-1: 17 V DC (between each input terminal and G)
OFF voltage	ID32ML: 5 V DC max. (between each input terminal and V) ID32M-1: 5 V DC max. (between each input terminal and G)
OFF current	1 mA max.
Insulation method	Photocoupler
Max. simultaneous input points	32 points
Number of circuits	32 points/single common circuit

Simultaneous Input Points and Installation Spacing

For Connector Terminals with 32 transistor inputs, the ambient operating temperature places a limit on the maximum number of points that can be turned ON simultaneously.

For example, if Connector Terminals are mounted in a direction other than the following directions at an ambient operating temperature of 55°C with all the 32 input points turned ON simultaneously, the Connector Terminals must not be mounted closely together.

- a. Input Units mounted upside down
- b. Input Units mounted horizontally with the MIL connectors facing downward
- c. Input Units mounted facing downward

If 32 input points of any Unit mounted in the above directions need to be turned ON simultaneously, the spacing between the Units is limited as shown in the following graph. For example, if the ambient operating temperature is 55°C, a minimum space of 10 mm is required between Units.

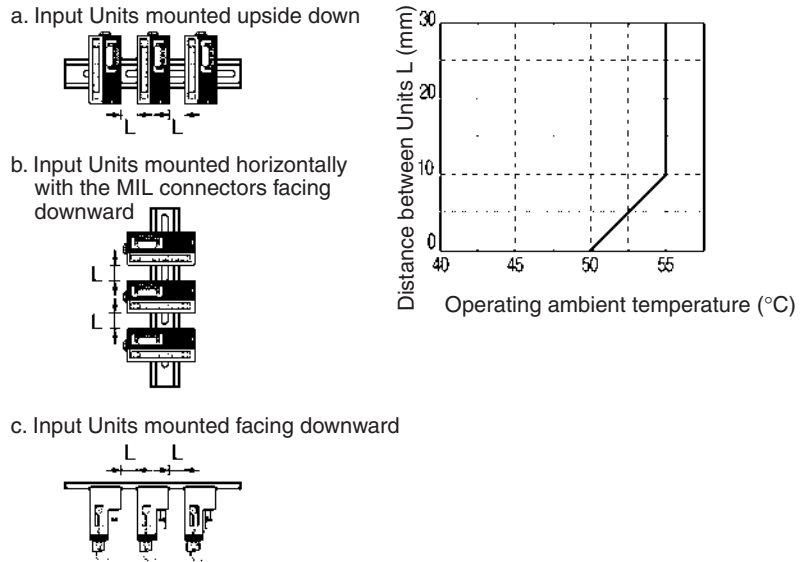

Slave Components

The following diagram shows the main components of the SRT2-ID32ML (-□) Connector Terminals with Transistor Inputs. The functions of these components are described below.

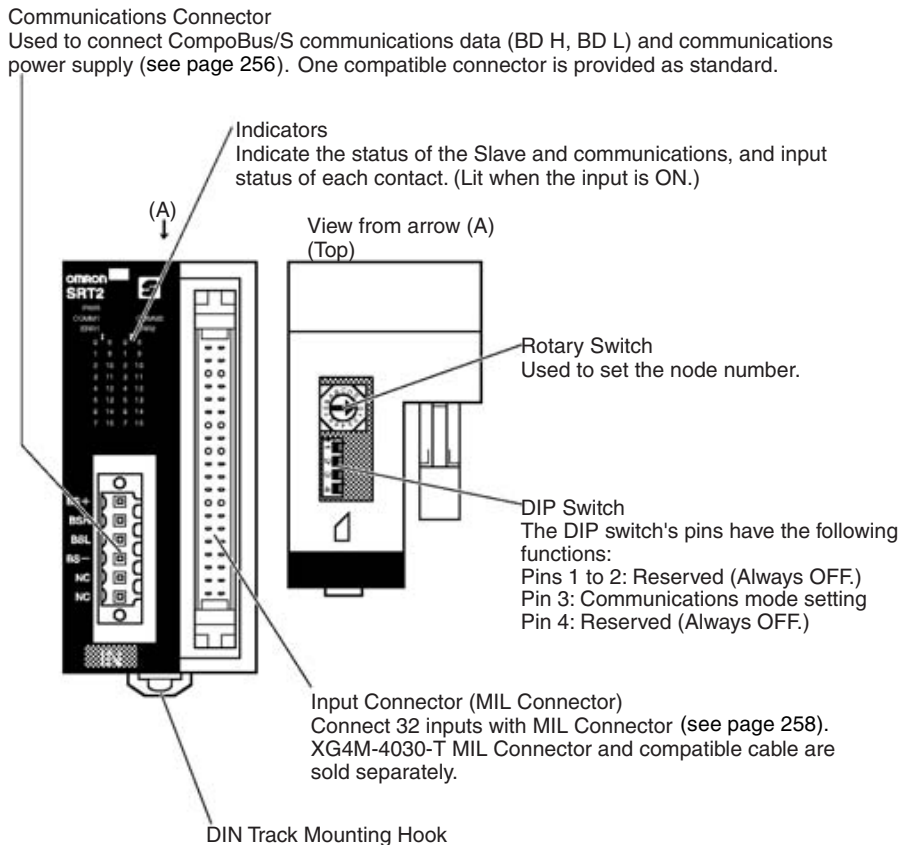

Indicators

The following table shows the meaning of the indicators.

Indicator	Name	Status	Meaning
PWR (green)	Power	ON	The communications power supply is ON.
		OFF	The communications power supply is OFF.
COMM1 (yellow)	Communica-tions	ON	Normal communications on word m.
		OFF	A communications error has occurred on word m or the Unit is in standby status.
COMM2 (yellow)		ON	Normal communications on word m+1.
		OFF	A communications error has occurred on word m+1 or the Unit is in standby status.
ERR1 (red)	Communica-tions error	ON	A communications error has occurred on word m.
		OFF	Normal communications on word m or the Unit is in standby status.
ERR2 (red)		ON	A communications error has occurred on word m+1.
		OFF	Normal communications on word m+1 or the Unit is in standby status.
I (yellow) 0 to 15 (16 inputs)	Input	ON	The corresponding input on word m is ON.
		OFF	The corresponding input is OFF or the Unit is in standby status.
II (yellow) 0 to 15 (16 inputs)		ON	The corresponding input on word m+1 is ON.
		OFF	The corresponding input on word m+1 is OFF or the Unit is in standby status.

Note Word m is the first word allocated in the Unit.

Switch Settings

The rotary switch and the DIP switch are located on the upper part of the Connector Terminal.

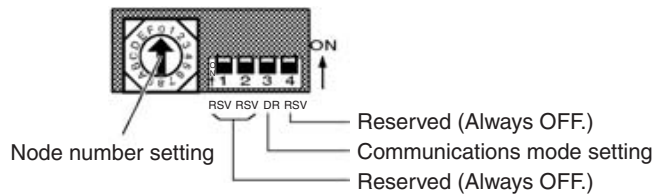

Note Always turn OFF the Slave before changing switch settings.

Node Number Settings

Set the node number in hexadecimal with the rotary switch as shown in the following table.

Node number	Setting (Hex)	Node number	Setting (Hex)
0	0	8	8
1	1	9	9
2	2	10	A
3	3	11	B
4	4	12	C
5	5	13	D
6	6	14	E
7	7	15	F

- Note**
1. The node number of the 32-point Slave must be set to an even number. If an odd number is input, the odd number less one will be set in the Slave.
 2. The possible range of node numbers varies with the type of Master and settings in the Master. Refer to 2-1 Communications Specifications for details.

Communications Mode Settings

The following communications modes are set with pin 3 of the DIP switch.

Pin 3	Communications mode	Communica-tions distance	Communica-tions baud rate	Communica-tions cycle time
OFF	High-speed Com-munications Mode	100 m max.	750 kbps	0.5 or 0.8 ms
ON	Long-distance Com-munications Mode	500 m max.	93.75 kbps	4.0 or 6.0 ms

- Note** Make sure that the communications mode of the Slave is the same as that of the Master Unit. If the communications modes are not the same, normal communications with the Master Unit will not be possible. The operating status of the Slave can be verified with LED indicators. Refer to 6-5-1 Indicators.

Internal Circuits

SRT2-ID32ML

The following diagram shows the internal circuits for the SRT2-ID32ML.

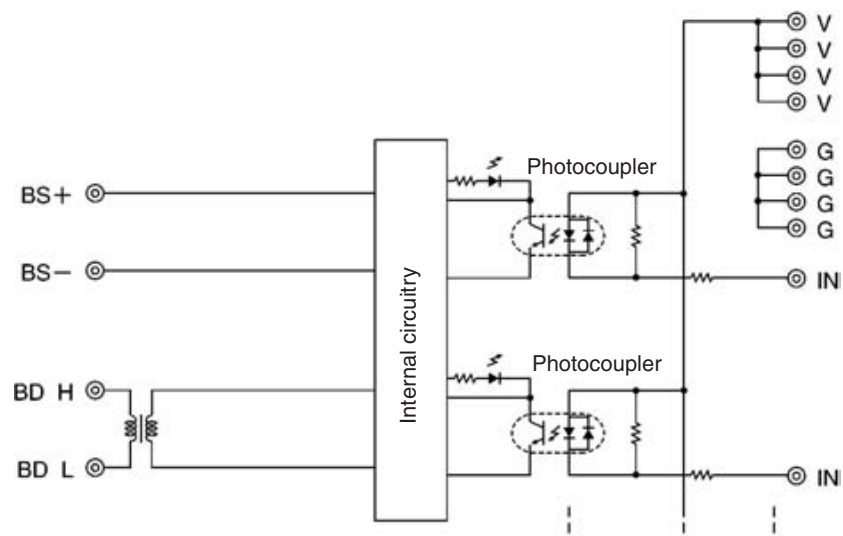

SRT2-ID32ML-1

The following diagram shows the internal circuits for the SRT2-ID32ML-1.

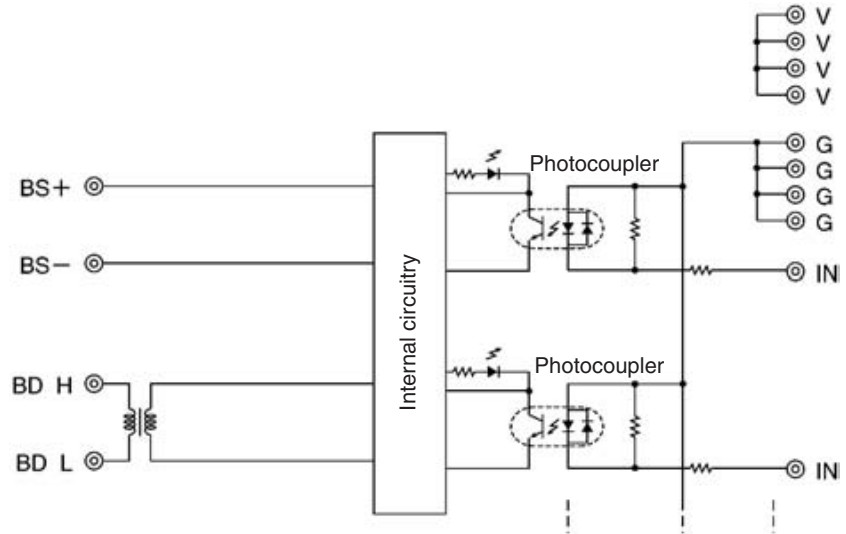

Wiring

Communications Connector Pin Arrangement

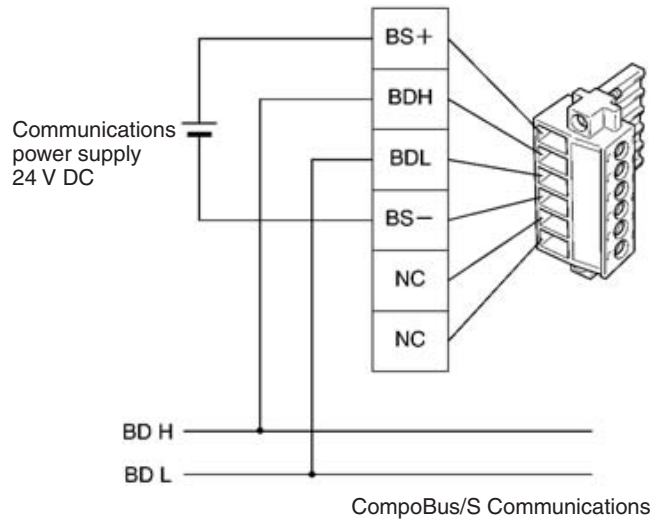

The communications connector (provided as standard) can be ordered as the following product:
BL3.5/6F (product no. 160668) manufactured by Weidmuller Co., Ltd.

- Note** 1. OMRON recommends the following products manufactured by Weidmuller Co., Ltd. for use as crimp terminals.

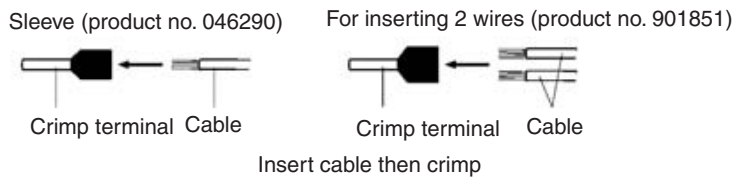

2. The following special tool is available:
Crimper PZ1.5 (product no. 900599) manufactured by Weidmuller Co., Ltd.

MIL Connector Pin Arrangement

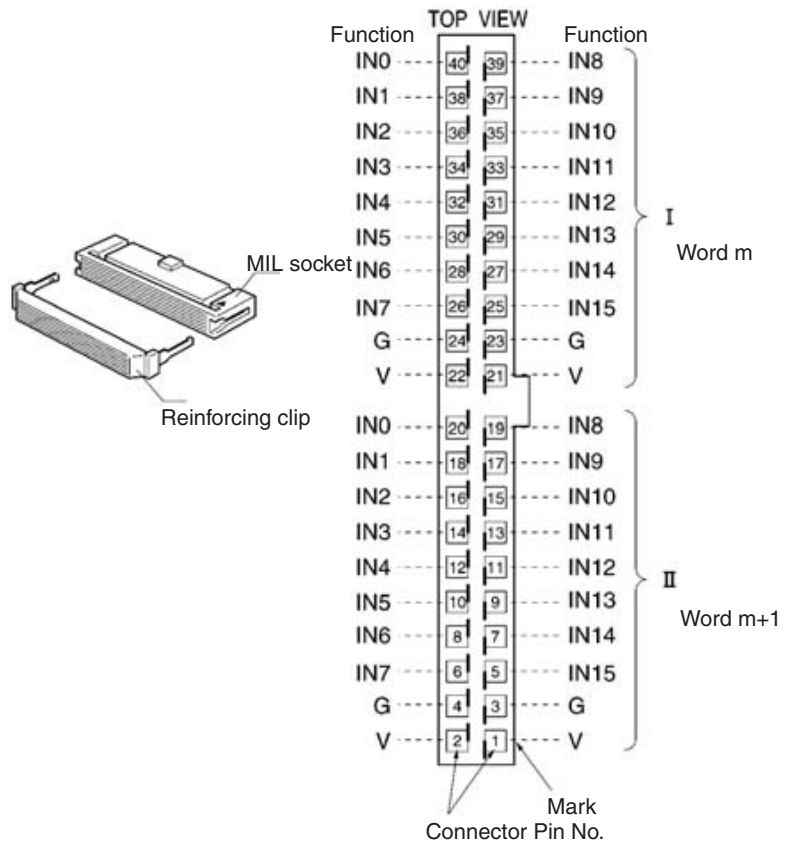

Name	Model
MIL connector	XG4M-4030-T

Note The XG4M-2030-T MIL Connector is not provided as standard and must be ordered separately.

Terminal Arrangement and Wiring Method

SRT2-ID32ML

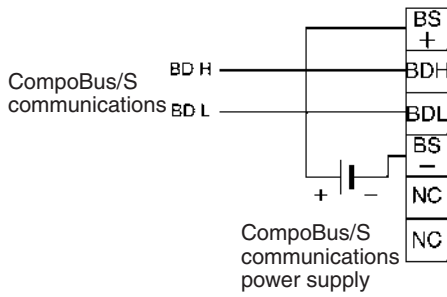

SRT2-ID32ML-1

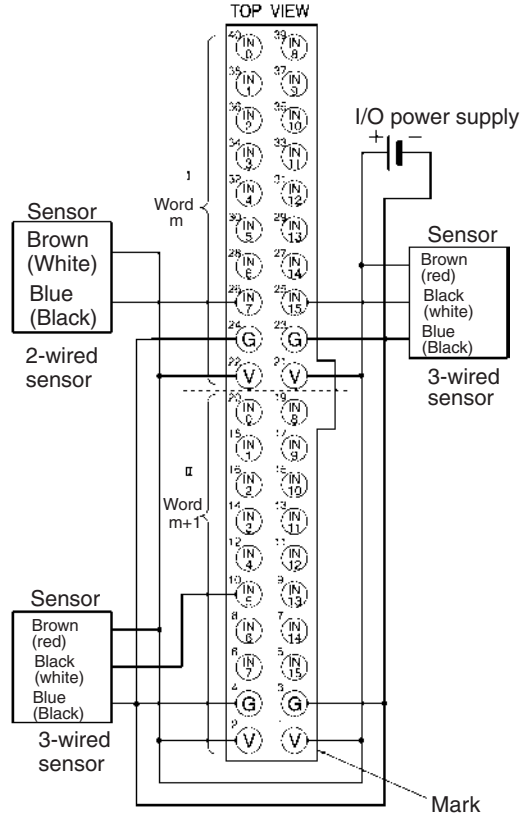
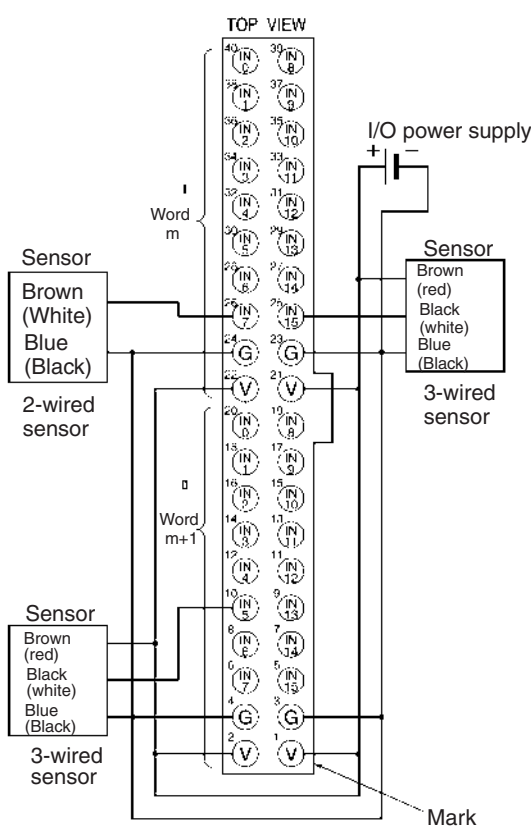
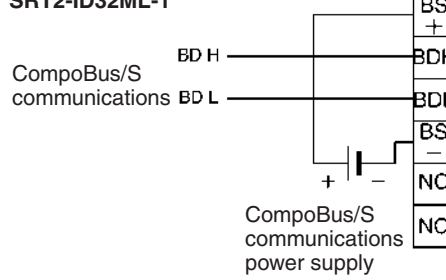

- Note**
1. The V terminals are all connected internally, as are the G terminals.
 2. Wire colors have been changed. Colors in parentheses are the old wire colors.

I/O Allocations

Provided that the first word of the Connector Terminal with 32 transistor inputs allocated to the Master Unit is m, the pin numbers of the MIL connector correspond to the following word and bit allocations.

	15	14	13	12	11	10	9	8	7	6	5	4	3	2	1	0	Bit
Word m	25	27	29	31	33	35	37	39	26	28	30	32	34	36	38	40	-- 16 inputs
Word m+1	5	7	9	11	13	15	17	19	6	8	10	12	14	16	18	20	-- 16 inputs

Compatible External Input Devices and Cables

Connector Terminals with 32 inputs connect to external devices over one of the following method.

- 1,2,3... 1. Using an XG4A-4030-T MIL Connector (sold separately) to Assemble Your Own Cable
For details, refer to *MIL Connector Wiring and Assembly* on page 258.

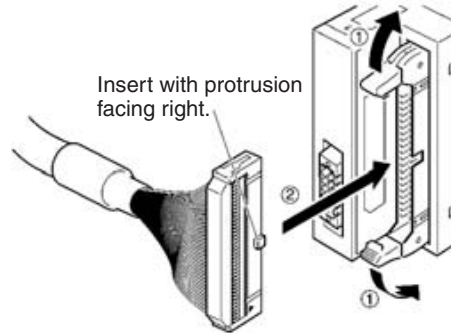

2. Connecting with OMRON Products Using MIL-compatible Cables Manufactured by OMRON
Select the MIL-compatible Cable from the following table according to the Connector Terminal and I/O Block to be connected.

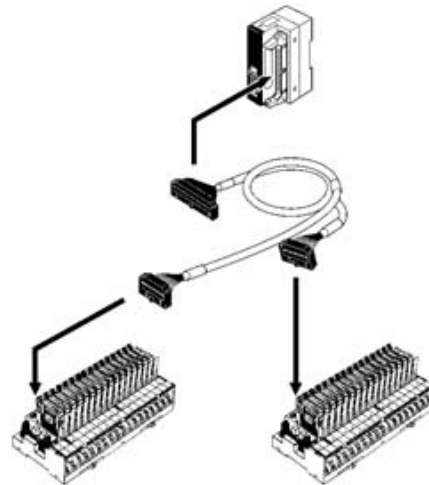

Slave model	MIL-compatible Cable	Connecting I/O block
SRT2-ID32ML	G79-I50-25-D1 (50 cm) G79-I75-50-D1 (75 cm)	G7TC-ID16 G7TC-IA16
SRT2-ID32ML-1	G79-I50-25-D2 (50 cm) G79-I75-50-D2 (75 cm)	G70A-ZIM16-5

Note MIL-compatible cables are not provided as standard and must be ordered separately.

The following cables are available, each of which is provided with a single MIL connector for the Connector Terminal end.

MIL-compatible cable	Remarks
G79-A200C-D1 (2 m) G79-A500C-D1 (5 m)	Wire dia.: AWG28 (other end) All wires are precut.
G79-Y100C-D1 (1 m) G79-Y200C-D1 (2 m) G79-Y500C-D1 (5 m)	Fork terminals provided to other end. Fork terminal: Nippon Tanshi's 161071-M2

The pin numbers of the MIL connector corresponds to the following color wires marked with color dots.

Pin	Wire color	Dots	Dot color	Pin	Wire color	Dots	Dot color
1	Light brown	■	Black	21	Light brown	■■■■	Black
2			Red	22			Red
3	Yellow		Black	23	Yellow		Black
4			Red	24			Red
5	Light green		Black	25	Light green		Black
6			Red	26			Red
7	Gray		Black	27	Gray		Black
8			Red	28			Red
9	White		Black	29	White		Black
10			Red	30			Red
11	Light brown	■■	Black	31	Light brown	■■■■■	Black
12			Red	32			Red
13	Yellow		Black	33	Yellow		Black
14			Red	34			Red
15	Light green		Black	35	Light green		Black
16			Red	36			Red
17	Gray		Black	37	Gray		Black
18			Red	38			Red
19	White		Black	39	White		Black
20			Red	40			Red

Dimensions

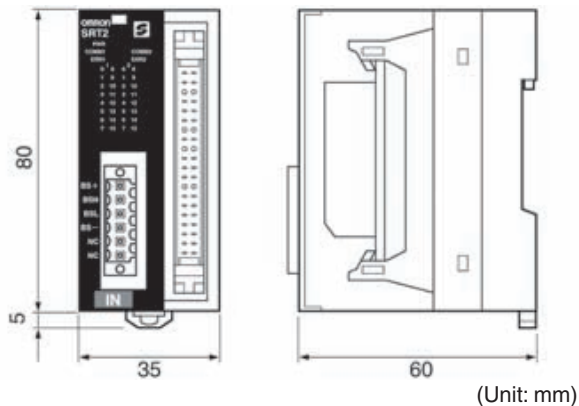

Wired Dimensions

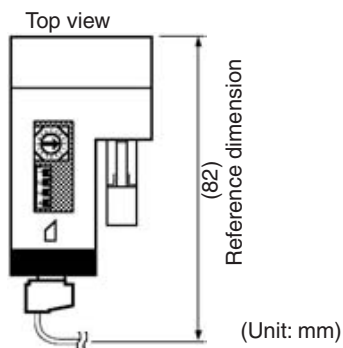

Mounting Methods

The following mounting methods can be used. These methods are the same as those used for mounting Connector Terminals with 8 or 16 inputs.

- DIN track mounting (with no mounting brackets): Refer to page 208.
- Vertical panel mounting (with Mounting Bracket B only): Refer to page 210.
- Horizontal panel mounting (with Mounting Bracket B only): Refer to page 210.

Note The 32-point Connector Terminals cannot be directly panel-mounted with screws. Use the SRT2-ATT02 Mounting Bracket B.

Mounting Bracket Dimensions

SRT2-ATT02 Mounting Bracket B

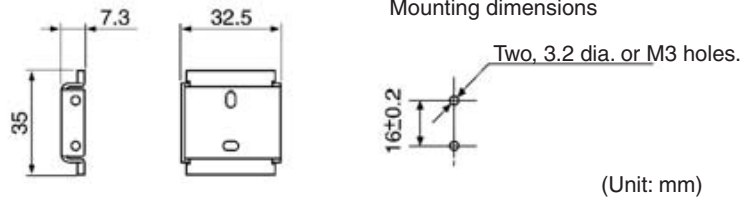

Mounting Dimensions

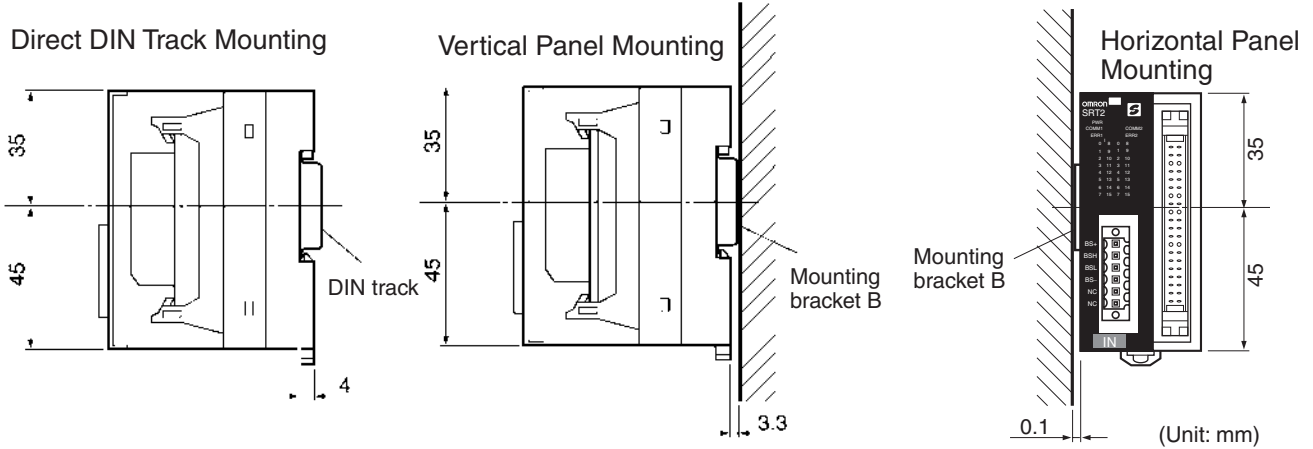

Distance from Duct

Keep the Unit at least 20 mm away from the upper and lower ducts.

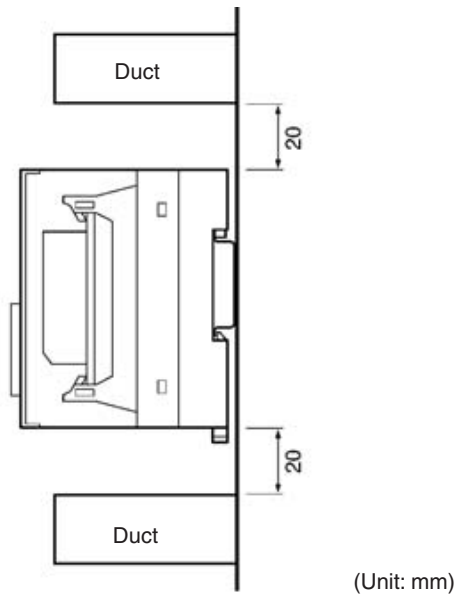

5-2-4 SRT2-OD32ML (-1) Connector Terminals with 32 Transistor Outputs

Specifications

The following tables show the ratings and output specifications for the SRT2-OD32ML (-1).

Ratings

Item	Specification
Models	SRT2-OD32ML, SRT2-OD32ML-1
Output points/Connection type	SRT2-OD32ML: 32 points (NPN)/MIL connector output SRT2-OD32ML-1: 32 points (PNP)/MIL connector output
Connection	Communications power: By communications connector (included as standard) Output: MIL connector or MIL-compatible Cables (both sold separately) (see page 243) I/O power: MIL connector
Power supply type	Multiple power supplies
Communications power supply voltage	14 to 26.4 V DC (Power can be supplied from the communications cable)
I/O power supply voltage	20.4 to 26.4 V DC (24 V DC $+10\%/_{-15\%}$)
Current consumption (See note.)	Communications power: 70 mA max. at 24 V DC
Noise immunity	1.5 kVp-p with a pulse width of 0.1 to 1 μ s and a rise time of 1 ns (tested with impulse noise simulator)
Vibration resistance	10 to 150 Hz, 0.7-mm double amplitude or 50 m/s ²
Shock resistance	150 m/s ²
Dielectric strength	500 V AC (between insulated circuits)
Ambient temperature	Operating: -10 to 55°C (with no icing or condensation) Storage: -25 to 65°C (with no icing or condensation)
Ambient humidity	Operating: 25% to 85% (with no condensation) Storage: 25% to 85% (with no condensation)
Operating environment	No corrosive gases
Standard accessory	1 communications connector Note Mounting Brackets B (SRT2-ATT02) is sold separately
Mounting strength	50 N
Terminal strength	Pulling: As stated below Communications connector: 30 N MIL connector: 30 N
Tightening torque	Communications connector: 0.25 to 0.3 N • m
Node number settings	The node number is set on a DIP switch. (Set the node number before turning ON the Slave.)
Weight	Approx. 90 g max.

Note This is the current consumption when all the maximum simultaneous input points are ON, excluding the current consumption of external loads.

Output Specifications

Item	Specifications
Output current	0.3 max./point (4 A common) (See note.)
Residual voltage	OD32ML: 1.2 V max. (0.3 A DC between each output terminal and G) OD32ML-1: 1.2 V max. (0.3 A DC between each output terminal and V)
Leakage current	OD32ML: 0.1 mA max. OD32ML-1: 0.1 mA max.
ON delay time	0.5 ms max.
OFF delay time	1.5 ms max.
Insulation method	Photocoupler
Number of circuits	32 points/single common circuit

Note When using the V and G terminals of the MIL connector, make sure that current does not exceed 1 A at each terminal.

Slave Components

The following diagram shows the main components of the SRT2-OD32ML (-□) Connector Terminals with Transistor Outputs. The functions of these components are described below.

Communications Connector

Used to connect CompoBus/S communications data (BD H, BD L) and communications power supply (see page 256). One compatible connector is provided as standard.

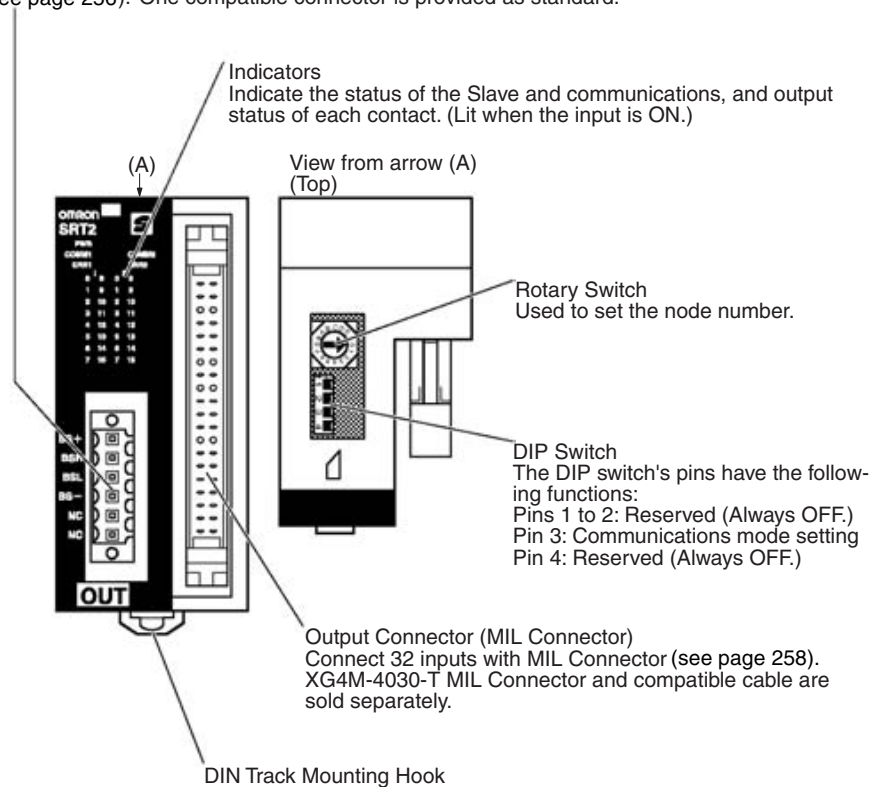

Indicators

The following table shows the meaning of the indicators.

Indicator	Name	Status	Meaning
PWR (green)	Power	ON	The communications power supply is ON.
		OFF	The communications power supply is OFF.
COMM1 (yellow)	Communications	ON	Normal communications on word n.
		OFF	A communications error has occurred on word n or the Unit is in standby status.
COMM2 (yellow)		ON	Normal communications on word n+1.
		OFF	A communications error has occurred on word n+1 or the Unit is in standby status.
ERR1 (red)	Communications error	ON	A communications error has occurred on word n.
		OFF	Normal communications on word n or the Unit is in standby status.
ERR2 (red)		ON	A communications error has occurred on word n+1.
		OFF	Normal communications on word n+1 or the Unit is in standby status.
I (yellow) 0 to 15 (16 outputs)	Outputs	ON	The corresponding output on word n is ON.
		OFF	The corresponding output is OFF or the Unit is in standby status.
II (yellow) 0 to 15 (16 inputs)		ON	The corresponding output on word n+1 is ON.
		OFF	The corresponding output on word n+1 is OFF or the Unit is in standby status.

Note Word n is the first word allocated in the Unit.

Switch Settings

The rotary switch and the DIP switch are located on the upper part of the Connector Terminal.

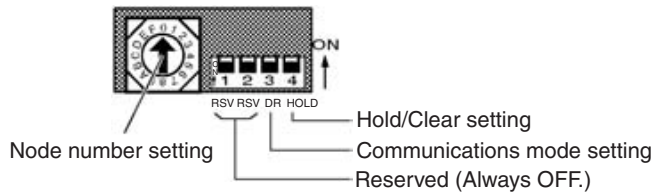

Note Always turn OFF the Slave before changing switch settings.

Node Number Settings

Set the node number in hexadecimal with the rotary switch as shown in the following table.

Node number	Setting (Hex)	Node number	Setting (Hex)
0	0	8	8
1	1	9	9
2	2	10	A
3	3	11	B
4	4	12	C
5	5	13	D
6	6	14	E
7	7	15	F

- Note**
1. The node number of the 32-point Slave must be set to an even number. If an odd number is input, the odd number less one will be set in the Slave.
 2. The possible range of node numbers varies with the type of Master and settings in the Master. Refer to *2-1 Communications Specifications* for details.

Communications Mode Settings

The following communications modes are set with pin 3 of the DIP switch as shown below.

SW3	Communications mode	Communications distance	Communications baud rate	Communications cycle time
OFF	High-speed Communications Mode	100 m max.	750 kbps	0.5 or 0.8 ms
ON	Long-distance Communications Mode	500 m max.	93.75 kbps	4.0 or 6.0 ms

- Note** Make sure that the communications mode of the Slave is the same as that of the Master Unit. If the communications modes are not the same, normal communications with the Master Unit will not be possible. The operating status of the Slave can be verified with LED indicators. Refer to *6-5-1 Indicators*.

Hold/Clear Outputs for Communications Errors

Pin 4 is used to set the output data status when a communications error occurs, as shown in the following table.

Pin 4 (HOLD)	Setting
OFF	Clear output status
ON	Maintain output status

Internal Circuits

SRT2-OD32ML

The following diagram shows the internal circuits for the SRT2-OD32ML.

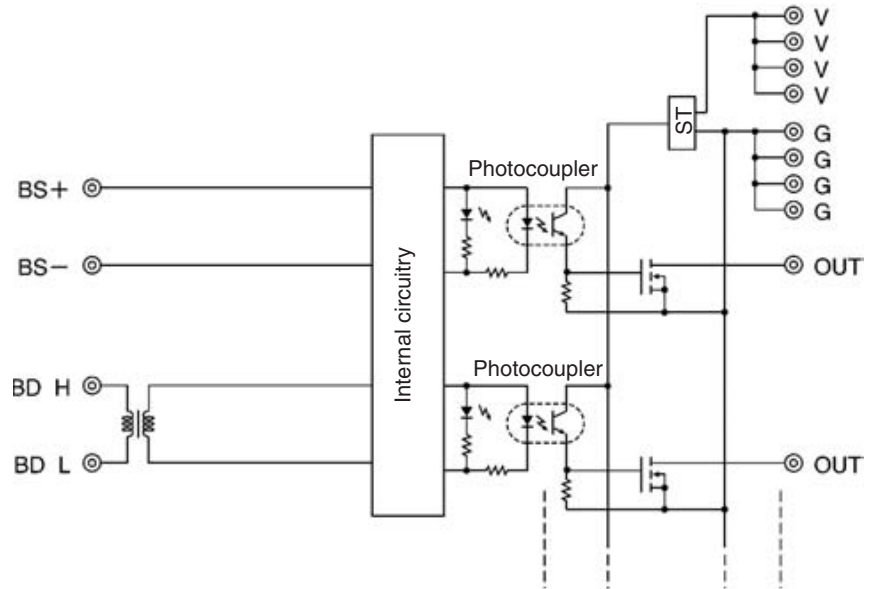

SRT2-OD32ML-1

The following diagram shows the internal circuits for the SRT2-OD32ML-1.

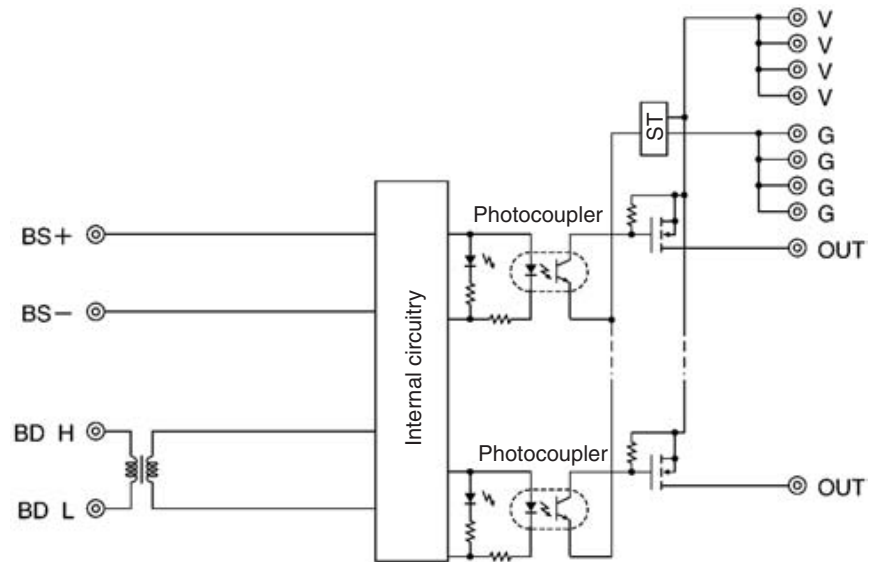

Wiring

Communications Connector Pin Arrangement

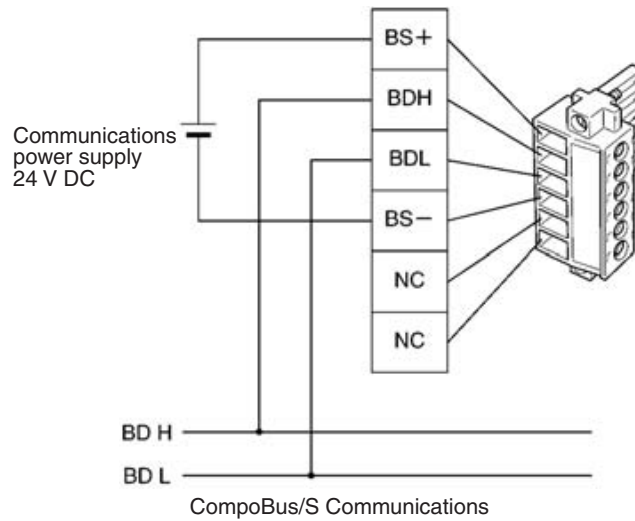

The communications connector (provided as standard) can be ordered as the following product:
 BL3.5/6F (product no. 160668) manufactured by Weidmuller Co., Ltd.

- Note** 1. OMRON recommends the following products manufactured by Weidmuller Co., Ltd. for use as crimp terminals.

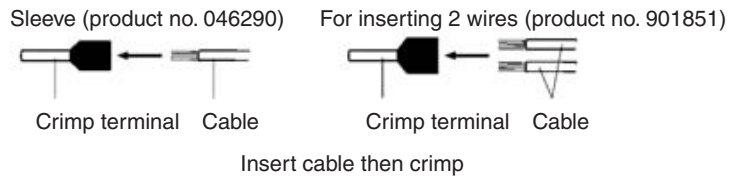

2. The following special tool is available: Crimper PZ1.5 (product no. 900599) manufactured by Weidmuller Co., Ltd.

MIL Connector Pin Arrangement

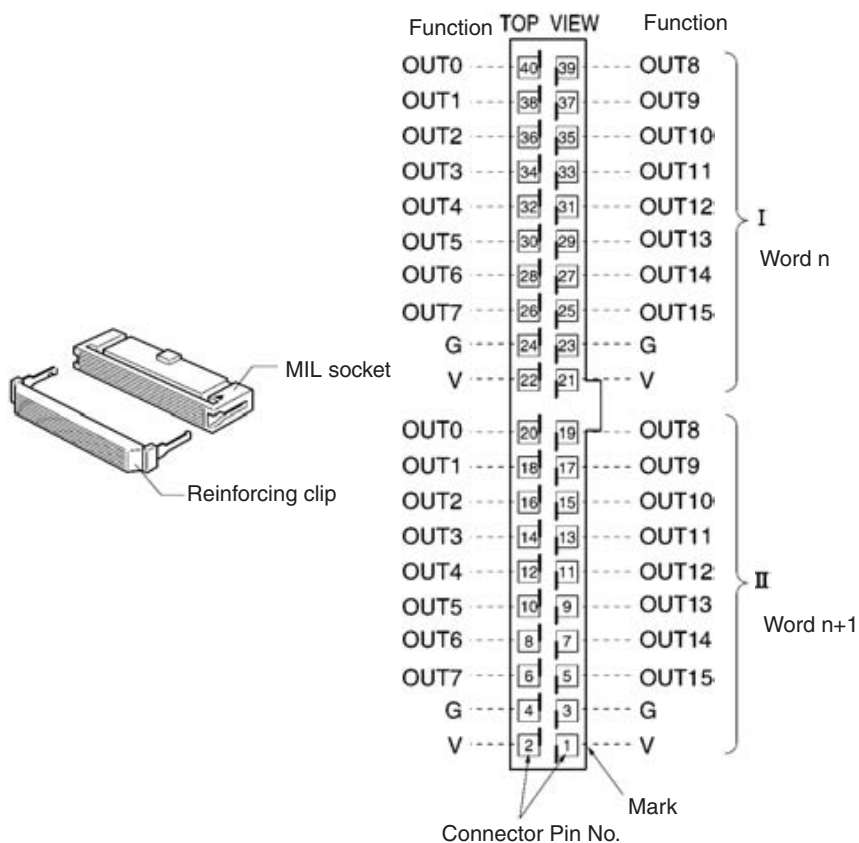

Name	Model
MIL connector	XG4M-4030-T

Note The XG4M-4030-T MIL Connector is not provided as standard and must be ordered separately.

Terminal Arrangement and Wiring Method

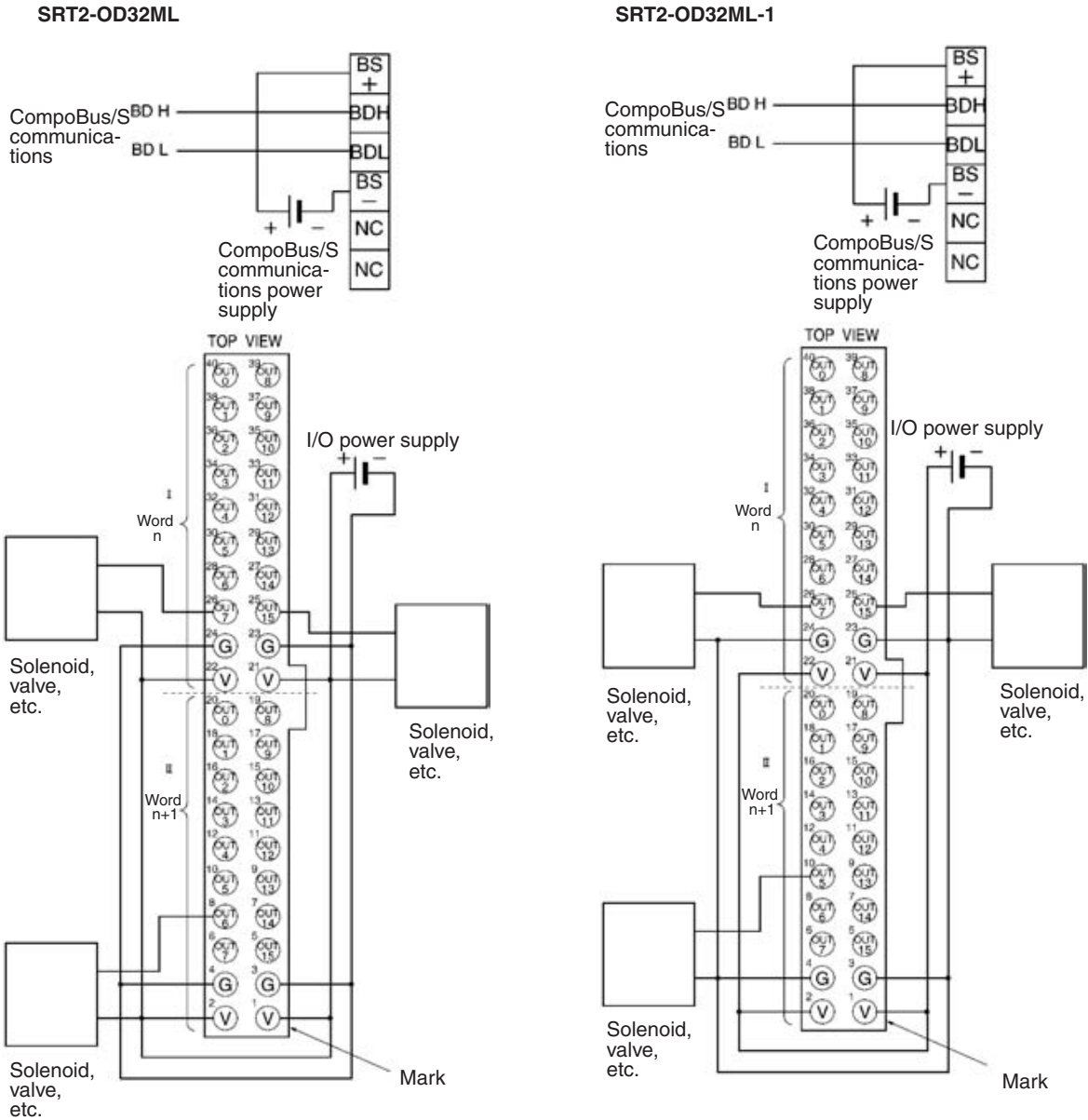

I/O Allocations

Provided that the first word of the Connector Terminal with 32 transistor outputs allocated to the Master Unit is n, the pin numbers of the MIL connector correspond to the following word and bit allocations.

	15	14	13	12	11	10	9	8	7	6	5	4	3	2	1	0	Bit
Word n	25	27	29	31	33	35	37	39	26	28	30	32	34	36	38	40	-- 16 outputs
Word n+1	5	7	9	11	13	15	17	19	6	8	10	12	14	16	18	20	-- 16 outputs

Compatible External Input Devices and Cables

The Connector Terminals with 32 inputs connect to external devices over one of the following method.

- 1,2,3... 1. Using an XG4A-4030-T MIL Connector (sold separately) to Assemble Your Own Cable
 For details, refer to *MIL Connector Wiring and Assembly* on page 258.

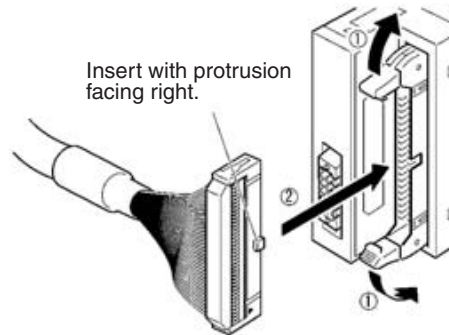

2. Connecting with OMRON Products Using an MIL-compatible Cables Manufactured by OMRON
 Select the MIL-compatible Cable from the following table according to the Connector Terminals and I/O Block to be connected.

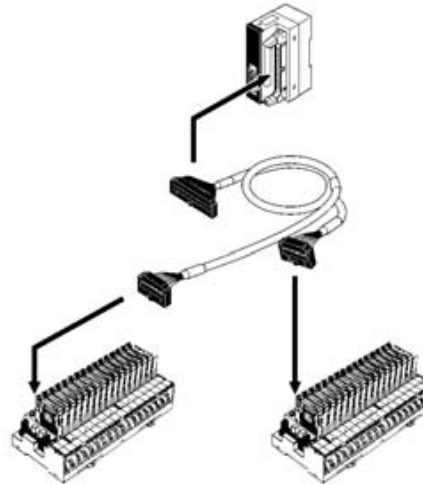

Slave model	MIL-compatible Cable	Connecting I/O block
SRT2-OD32ML	G79-O50-25-D1 (50 cm) G79-O75-50-D1 (75 cm)	G7TC-OC16/OC08 G70D-SOC16/VSOC16 G70A-ZOC16-3
SRT2-OD32ML-1	G79-O50-25-D1 (50 cm) G79-O75-50-D1 (75 cm)	G70A-ZOC16-4 G70D-SOC16-1
	G79-I50-25-D1 (50 cm) G79-I75-50-D1 (75 cm)	G7TC-OC16-4 M7F

Note MIL-compatible cables are not provided as standard and must be ordered separately.

The following cables are available, each of which is provided with a single MIL connector for the Connector Terminal end.

MIL-compatible cable	Remarks
G79-A200C-D1 (2 m) G79-A500C-D1 (5 m)	Wire dia.: AWG28 (other end) All wires are precut.
G79-Y100C-D1 (1 m) G79-Y200C-D1 (2 m) G79-Y500C-D1 (5 m)	Fork terminals provided to other end. Fork terminal: Nippon Tanshi's 161071-M2

The pin numbers of the MIL connector corresponds to the following color wires marked with color dots.

Pin	Wire color	Dots	Dot color	Pin	Wire color	Dots	Dot color
1	Light brown	■	Black	21	Light brown	■■■	Black
2			Red	22			Red
3	Yellow		Black	23	Yellow		Black
4			Red	24			Red
5	Light green		Black	25	Light green		Black
6			Red	26			Red
7	Gray		Black	27	Gray		Black
8			Red	28			Red
9	White		Black	29	White		Black
10			Red	30			Red
11	Light brown	■■	Black	31	Light brown	■■■■	Black
12			Red	32			Red
13	Yellow		Black	33	Yellow		Black
14			Red	34			Red
15	Light green		Black	35	Light green		Black
16			Red	36			Red
17	Gray		Black	37	Gray		Black
18			Red	38			Red
19	White		Black	39	White		Black
20			Red	40			Red

Dimensions

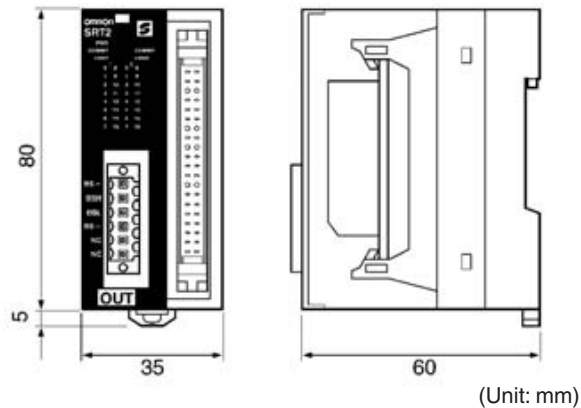

Note For details on wiring dimensions, refer to 5-2-3 SRT2-ID32ML (-1) Connector Terminals with 32 Transistor Inputs.

Mounting Methods

The following mounting methods are available. These methods are the same as those used for mounting Connector Terminals with 8 or 16 inputs.

- DIN track mounting (with no mounting brackets): Refer to page 208.
- Vertical panel mounting (with Mounting Bracket B only): Refer to page 210.
- Horizontal panel mounting (with Mounting Bracket B only): Refer to page 210.

Note 1. The 32-point Connector Terminal cannot be directly panel-mounted with screws. Use the SRT2-ATT02 Mounting Bracket B.

2. For details on wiring dimensions, refer to 5-2-3 SRT2-ID32ML (-1) Connector Terminals with 32 Transistor Inputs.

5-2-5 SRT2-MD32ML (-1) Connector Terminals with 16 Transistor Inputs and 16 Transistor Outputs

Specifications

The following tables show the ratings and I/O specifications for the SRT2-MD32ML (-1).

Ratings

Item	Specification
Models	SRT2-MD32ML, SRT2-MD32ML-1
Input points/Connection type	SRT2-MD32ML: 16 input and 16 output points (NPN)/MIL connector input SRT2-MD32ML-1: 16 input and 16 output points (PNP)/MIL connector input
Connection	Communications power: By communications connector (included as standard) Input: MIL connector or MIL-compatible Cables (both sold separately) (see page 253) I/O power: MIL connector
Power supply type	Multiple power supplies
Communications power supply voltage	14 to 26.4 V DC (Power can be supplied from the communications cable)
I/O power supply voltage	20.4 to 26.4 V DC (24 V DC $+10\%$ / -15%)
Current consumption (See note.)	Communications power: 60 mA max. at 24 V DC
Noise immunity	1.5 kVp-p with a pulse width of 0.1 to 1 μ s and a rise time of 1 ns (tested with impulse noise simulator)
Vibration resistance	10 to 150 Hz, 0.7-mm double amplitude or 50 m/s ²
Shock resistance	150 m/s ²
Dielectric strength	500 V AC (between insulated circuits)
Ambient temperature	Operating: -10 to 55°C (with no icing or condensation) Storage: -25 to 65°C (with no icing or condensation)
Ambient humidity	Operating: 25% to 85% (with no condensation) Storage: 25% to 85% (with no condensation)
Operating environment	No corrosive gases
Standard accessory	1 communications connector Note Mounting Bracket B (SRT2-ATT02) is sold separately
Mounting strength	50 N
Terminal strength	Pulling: As stated below. Communications connector: 30 N MIL connector: 30 N
Tightening torque	Communications connector: 0.25 to 0.3 N • m
Node number settings	The node number is set on a DIP switch. (Set the node number before turning ON the Slave.)
Weight	Approx. 100 g max.

Note This is the current consumption when all the maximum simultaneous input points are ON, excluding the current consumption of external sensors.

Input Specifications

Item	Specifications
Input current	6 mA max./point at 24 V DC 3 mA min./point at 17 V DC
ON delay time	1.5 ms max.
OFF delay time	1.5 ms max.
ON voltage	MD32MIL: 17 V DC min. (between each input terminal and V) MD32ML-1: 17 V DC min. (between each input terminal and G)
OFF voltage	MD32ML: 5 V DC max. (between each input terminal and V) MD32M-1: 5 V DC max. (between each input terminal and G)
OFF current	1 mA max.
Insulation method	Photocoupler
Max. simultaneous input points	16 points
Number of circuits	16 points/single common circuit

Output Specifications

Item	Specifications
Output current	0.3 max./point (4 A common) (See note.)
Residual voltage	MD32ML: 1.2 V max. (0.3 A DC between each output terminal and G) MD32ML-1: 1.2 V max. (0.3 A DC between each output terminal and V)
Leakage current	MD32ML: 0.1 mA max. MD32ML-1: 0.1 mA max.
ON delay time	0.5 ms max.
OFF delay time	1.5 ms max.
Insulation method	Photocoupler
Number of circuits	16 points/single common circuit

Note When using the V and G terminals of the MIL connector, make sure that current does not exceed 1 A at each terminal.

Simultaneous Input Points and Installation Spacing

For Connector Terminals with 16 transistor inputs and 16 transistor outputs, the ambient operating temperature places a limit on the maximum number of points that can be turned ON simultaneously.

For example, if Connector Terminals are to be mounted in the direction other than the following directions at an ambient operating temperature of 55°C with all the 16 points turned ON simultaneously, the Connector Terminals must not be mounted closely together.

- a. Units mounted upside down
- b. Units mounted horizontally with the MIL connectors facing downward
- c. Units mounted facing downward

If 16 points of any Unit mounted in the above directions need to be turned ON simultaneously, the spacing of the Units is limited as shown in the following

graph. For example, if the ambient operating temperature is 55°C, a minimum space of 10 mm is required between Units.

a. Units mounted upside down



b. Units mounted horizontally with the MIL connectors facing downward



c. Units mounted facing downward

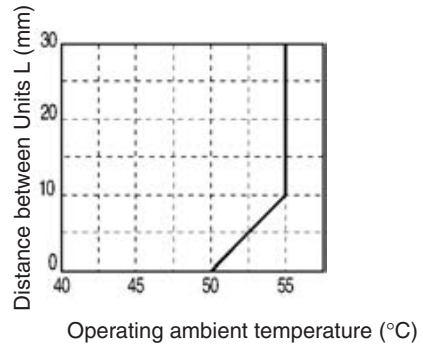
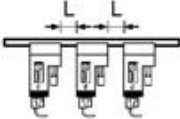

Slave Components

The following diagram shows the main components of the SRT2-MD32ML (-□) Connector Terminals with Transistor Inputs and Transistor Outputs. The functions of these components are described below.

Communications Connector
Used to connect CompoBus/S communications data (BD H, BD L) and communications power supply (see page 256). One compatible connector is provided as standard.

Indicators
Indicate the status of the Slave and communications, and input status of each contact. (Lit when the input is ON.)

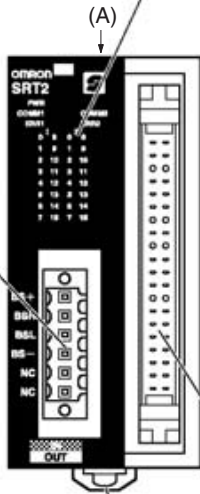

View from arrow (A) (Top)

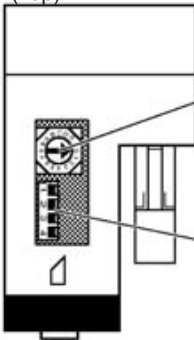

Rotary Switch
Used to set the node number.

DIP Switch
The DIP switch's pins have the following functions:
Pins 1 to 2: Reserved (Always OFF.)
Pin 3: Communications mode setting
Pin 4: Hold/Clear Outputs for Communications Errors

Input Connector (MIL Connector)
Connect 16 input and 16 output points with MIL Connector (see page 258). XG4M-4030-T MIL Connector and compatible cable are sold separately.

DIN Track Mounting Hook

Indicators

The following table shows the meaning of the indicators.

Indicator	Name	Status	Meaning
PWR (green)	Power	ON	The communications power supply is ON.
		OFF	The communications power supply is OFF.
COMM1 (yellow)	Communi-cations	ON	Normal communications on word m.
		OFF	A communications error has occurred on word m or the Unit is in standby status.
COMM2 (yellow)		ON	Normal communications on word n.
		OFF	A communications error has occurred on word n or the Unit is in standby status.
ERR1 (red)	Communi-cations error	ON	A communications error has occurred on word m.
		OFF	Normal communications on word m or the Unit is in standby status.
ERR2 (red)		ON	A communications error has occurred on word n.
		OFF	Normal communications on word n or the Unit is in standby status.
I (yellow) 0 to 15 (16 inputs)	I/O	ON	The corresponding input on word m is ON.
		OFF	The corresponding input is OFF or the Unit is in standby status.
II (yellow) 0 to 15 (16 outputs)		ON	The corresponding output on word n is ON.
		OFF	The corresponding output on word n is OFF or the Unit is in standby status.

Note Word m is the word allocated in the Unit as an input Slave. Word n is the word allocated in the Unit as an output Slave.

Switch Settings

The rotary switch and the DIP switch are located on the upper part of the Connector Terminal.

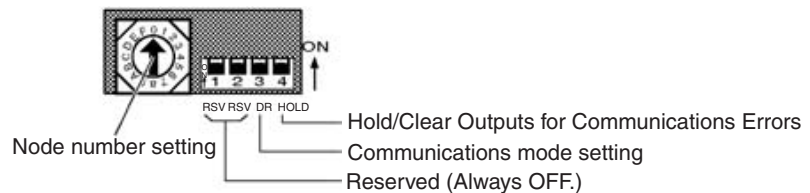

Note Always turn OFF the Slave before changing switch settings.

Node Number Settings

Set the node number in hexadecimal with the rotary switch as shown in the following table.

Node number	Setting (Hex)	Node number	Setting (Hex)
0	0	8	8
1	1	9	9
2	2	10	A
3	3	11	B
4	4	12	C
5	5	13	D
6	6	14	E
7	7	15	F

- Note**
1. The 32-point Slave is handled as a 16-point input Slave and a 16-point output Slave. The node number of the 32-point Slave must be set to an even number. If an odd number is input, the odd number less one will be set in the Slave.
 2. The possible range of node numbers varies with the type of Master and settings in the Master. Refer to *2-1 Communications Specifications* for details.

Communications Mode Settings

The following communications modes are set with pin 3 of the DIP switch as shown below.

Pin 3	Communications mode	Communications distance	Communications baud rate	Communications cycle time
OFF	High-speed Communications Mode	100 m max.	750 kbps	0.5 or 0.8 ms
ON	Long-distance Communications Mode	500 m max.	93.75 kbps	4.0 or 6.0 ms

Note Make sure that the communications mode of the Slave is the same as that of the Master Unit. If the communications modes are not the same, normal communications with the Master Unit will not be possible. The operating status of the Slave can be verified with LED indicators. Refer to *6-5-1 Indicators* for details.

Hold/Clear Outputs for Communications Error

Pin 4 is used to set the output data status when a communications error occurs, as shown in the following table.

Pin 4 (HOLD)	Output setting
OFF	Clear output status.
ON	Maintain output status.

Internal Circuits

SRT2-MD32ML

The following diagram shows the internal circuits for the SRT2-MD32ML.

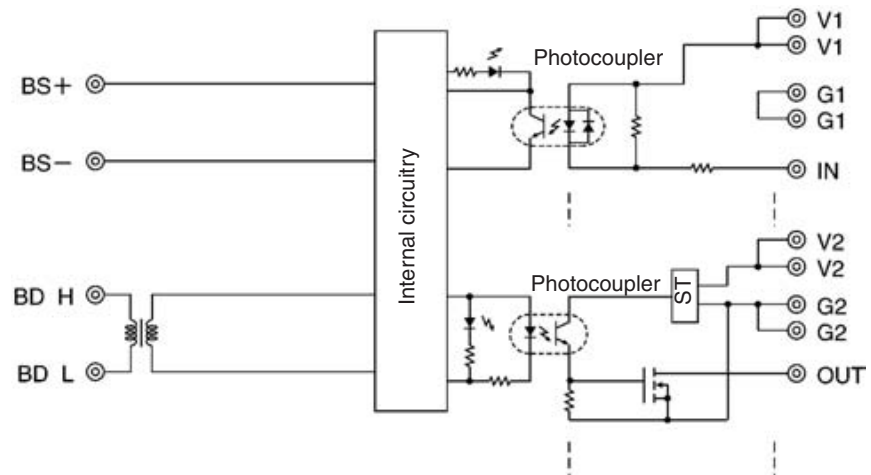

SRT2-MD32ML-1

The following diagram shows the internal circuits for the SRT2-MD32ML-1.

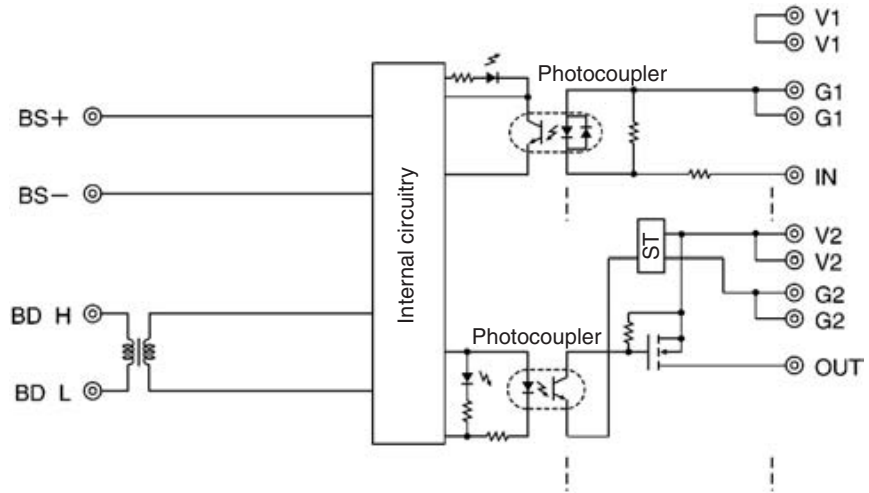

Wiring

Communications Connector Pin Arrangement

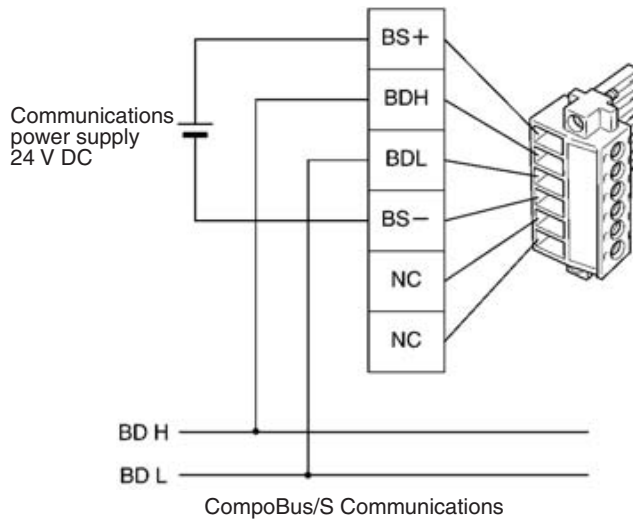

The communications connector (provided as standard) can be ordered as the following product:
BL3.5/6F (product no. 160668) manufactured by Weidmuller Co., Ltd.

- Note** 1. OMRON recommends the following products manufactured by Weidmuller Co., Ltd. for use as crimp terminals.

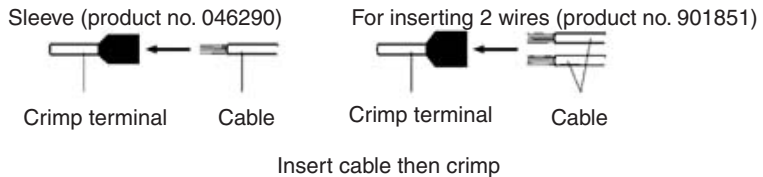

2. The following special tool is available:
Crimper PZ1.5 (product no. 900599) manufactured by Weidmuller Co., Ltd.

MIL Connector Pin Arrangement

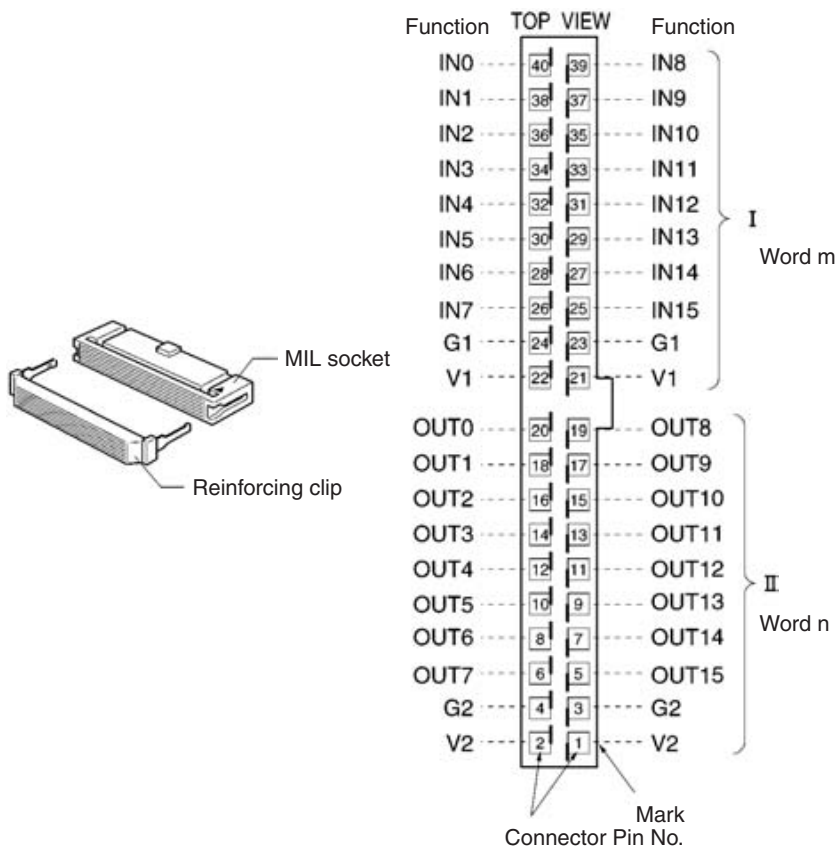

Name	Model
MIL connector	XG4M-4030-T

Note The XG4M-4030-T MIL Connector is not provided as standard and must be ordered separately.

Terminal Arrangement and Wiring Method

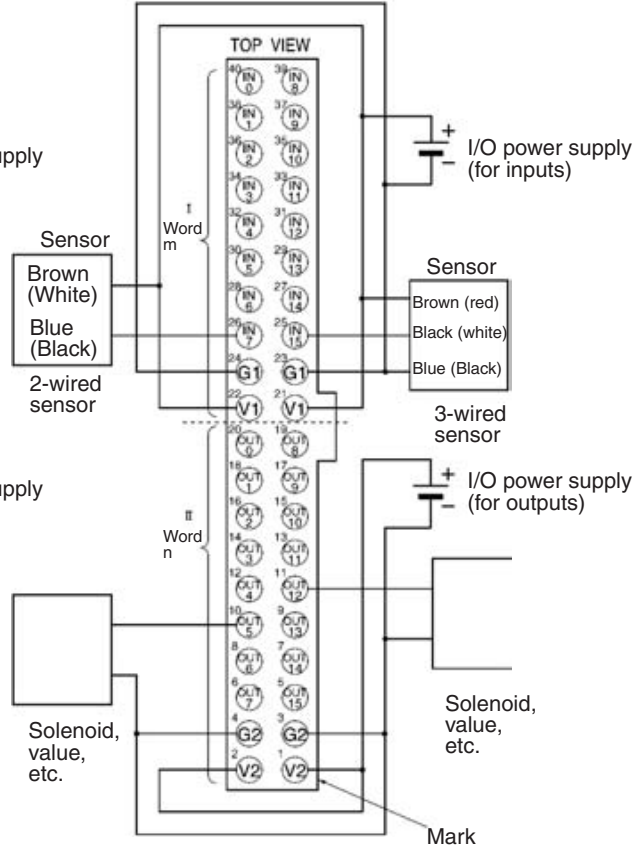
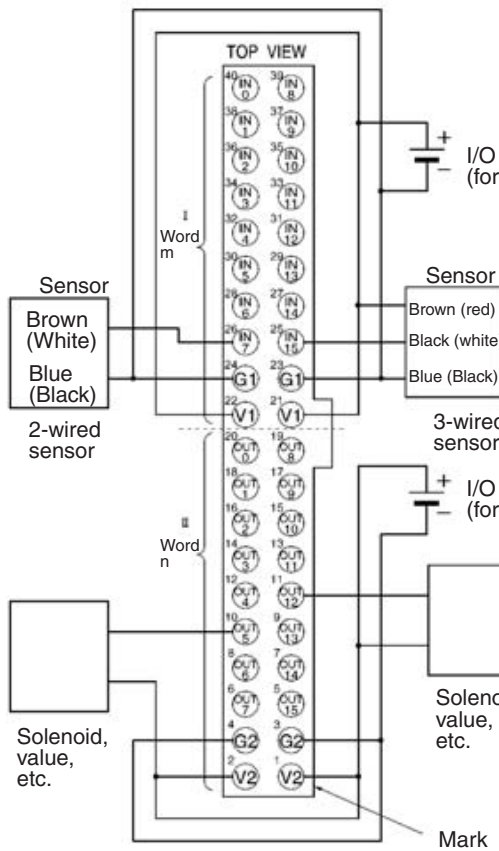
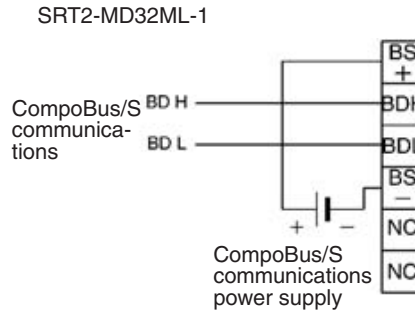
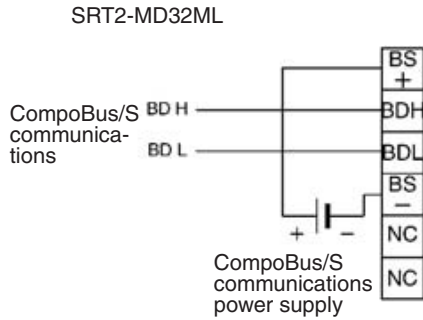

Note In accordance with the changes in the standards for photoelectric sensors and proximity sensors, wire colors have been changed. Colors in parentheses are the old wire colors.

I/O Allocations

Provided that the words of the Connector Terminal with 32 transistor inputs and 32 transistor outputs allocated as input and output Slaves to the Master Unit are m and n, the pin numbers of the MIL connector correspond to the following word and bit allocations.

	15	14	13	12	11	10	9	8	7	6	5	4	3	2	1	0	Bit
Word m	25	27	29	31	33	35	37	39	26	28	30	32	34	36	38	40	- - 16 inputs
Word n	5	7	9	11	13	15	17	19	6	8	10	12	14	16	18	20	- - 16 outputs

Compatible External Input Devices and Cables

The Connector Terminals with 32 inputs connect to external devices over one of the following method.

- 1,2,3... 1. Using an XG4A-4030-T MIL Connector (sold separately) to Assemble Your Own Cable
For details, refer to *MIL Connector Wiring and Assembly* on page 258.

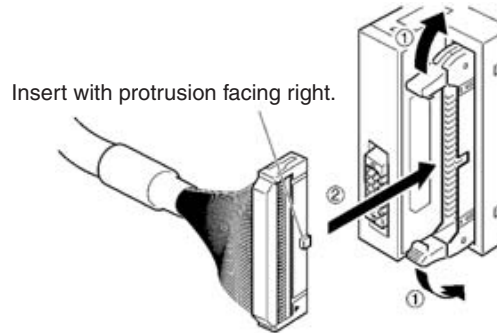

2. Connecting with OMRON Products Using an MIL-compatible Cables Manufactured by OMRON
Select the MIL-compatible Cable from the following table according to the Connector Terminals and I/O Block to be connected.

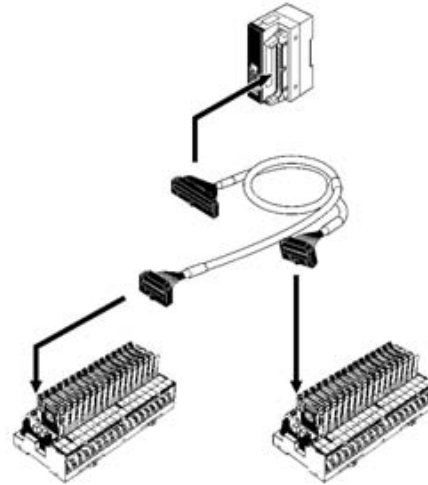

Slave model	MIL-compatible Cable	Connecting I/O block	Remarks
SRT2-MD32ML	G79-M50-25-D1 (50 cm) G79-M75-50-D1 (75 cm)	Inputs:G7TC-ID16/IA16 Outputs:G7TC-OC08/OC16 G7OD-SOC16/VSOC16 G70A-ZOC16-3	Input and output wires can be distinguished with the following colors. Inputs: Red Outputs: Yellow
SRT2-MD32ML-1	G79-M50-25-D2 (50 cm) G79-M75-50-D2 (75 cm)	Inputs:G70A-ZIM16-5 Outputs:G70A-ZOC16-4 G70D-SOC16-1	

Note MIL-compatible cables are not provided as standard and must be ordered separately.

The following cables are available, each of which is provided with a single MIL connector for the Connector Terminal end.

MIL-compatible cable	Remarks
G79-A200C-D1 (2 m) G79-A500C-D1 (5 m)	Wire dia.: AWG28 (other end) All wires are precut.
G79-Y100C-D1 (1 m) G79-Y200C-D1 (2 m) G79-Y500C-D1 (5 m)	Fork terminals provided to other end. Fork terminal: Nippon Tanshi's 161071-M2

The pin numbers of the MIL connector corresponds to the following color wires marked with color dots.

Pin	Wire color	Dots	Dot color	Pin	Wire color	Dots	Dot color
1	Light brown	■	Black	21	Light brown	■■■■	Black
2			Red	22			Red
3	Yellow		Black	23	Yellow		Black
4			Red	24			Red
5	Light green		Black	25	Light green		Black
6			Red	26			Red
7	Gray		Black	27	Gray		Black
8			Red	28			Red
9	White		Black	29	White		Black
10			Red	30			Red
11	Light brown	■■	Black	31	Light brown	■■■■■	Black
12			Red	32			Red
13	Yellow		Black	33	Yellow		Black
14			Red	34			Red
15	Light green		Black	35	Light green		Black
16			Red	36			Red
17	Gray		Black	37	Gray		Black
18			Red	38			Red
19	White		Black	39	White		Black
20			Red	40			Red

Dimensions

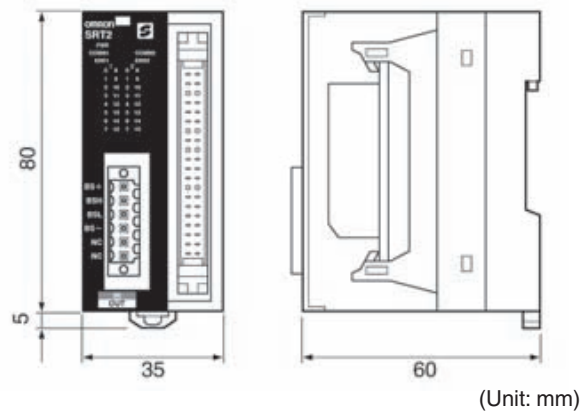

Note For details on wiring dimensions, refer to 5-2-3 SRT2-ID32ML (-1) Connector Terminals with 32 Transistor Inputs.

Mounting Methods

The following mounting methods are available. These methods are the same as those used for mounting Connector Terminals with 8 or 16 inputs.

- DIN track mounting (with no mounting brackets): Refer to page 208.
- Vertical panel mounting (with Mounting Bracket B only): Refer to page 210.
- Horizontal panel mounting (with Mounting Bracket B only): Refer to page 210.

Note 1. The 32-point Connector Terminal cannot be directly panel-mounted with screws. Use the SRT2-ATT02 Mounting Bracket B.

2. For details on wiring dimensions, refer to 5-2-3 SRT2-ID32ML (-1) Connector Terminals with 32 Transistor Inputs.

5-2-6 Wiring and Assembly of Communications Connector and MIL Connector for Connector Terminals

Connect the communications cable to the Connector Terminal using the rectangular communications connector provided with the Unit. The Connector Terminals with MIL connectors are used to connect the external I/O. The wiring and assembly methods of square communications connectors and MIL connectors are described here.

The Connector Terminals with sensor connectors are used to connect the external I/O cable connector. The cable connector wiring and assembly methods are the same as for Sensor Terminals, so refer to 3-4-3 Cable Connector Wiring and Assembly for details.

Wiring

A CompoBus/S cable must be connected to a Connector Terminal after the communications data (BD H, BD L), communications power supply (BS+, BS-), and I/O power supply (G, V) lines are connected to the communications connector (i.e., the connector on the cable end). I/O power is not supplied to 32-point Connector Terminals.

! Caution Be sure to turn OFF the Slave power supply and communications power supply before connecting communications data, communications power supply, or I/O power supply lines, and before attaching or detaching connectors. For the connector, use the communications connector provided with the Connector Terminal.

Use the following procedure to connect the communications data, communications power supply, and I/O power supply lines to the connector.

- 1,2,3... 1. Remove sufficient insulation from the signal wires for a crimp terminal, and twist the exposed wire strands together tightly.



If using VCTF cable, cover the severed end of the insulation with vinyl tape or heat-shrinking tube.

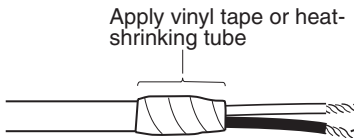

2. After attaching a crimp terminal to the exposed signal wires, cover with vinyl tape or heat-shrinking tube.

OMRON recommends the following products manufactured by Weidmuller Co., Ltd. for use as crimp terminals.

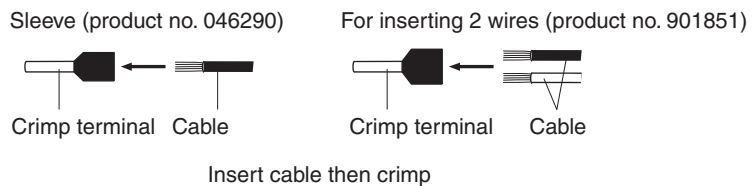

The following special tool is available:
Crimper PZ1.5 (product number 900599) manufactured by Weidmuller Co., Ltd.

3. Paying attention to the orientation of the connector, insert each signal wire into the corresponding hole in the connector, as shown below.

SRT2-V□D□□□□ (-1)

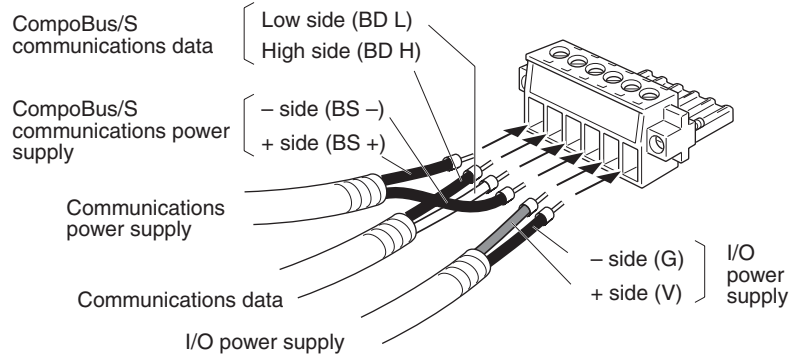

SRT2-□32ML (-1)

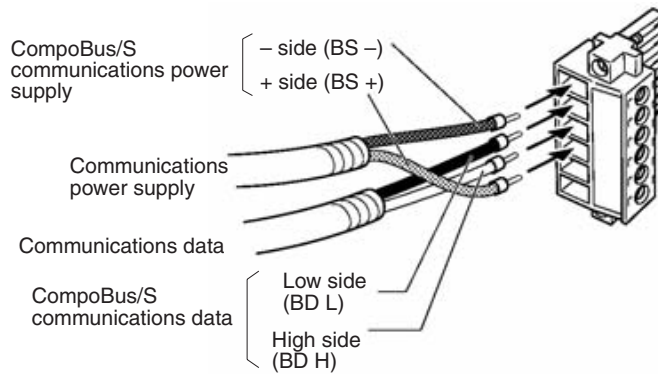

⚠ Caution Before inserting the signal wires, loosen the clamp screws used to secure wires to the connector. If a wire is inserted before the corresponding screw is loosened, the wire may enter the gap behind the connector, and remain unsecured. Use crimp terminals when wiring. Do not attach twisted bare wires directly to connectors.

4. Tighten the clamp screws securing each signal wire to the connector. Note that a normal screwdriver has a keystone tip with a flared blade, and may not be able to penetrate deeply enough to reach the screw. Use a small slotted screwdriver of constant width. The correct tightening torque is 0.2 to 0.4 N·m.

The following example is for the SRT2-V□D□□□□(-1).

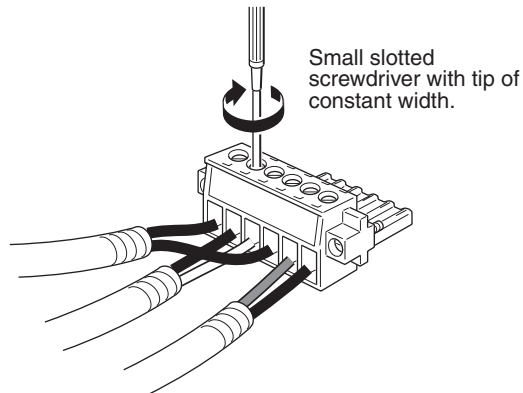

Note Use a fine-tipped screwdriver. The size of the communications Connector Terminal screws is M2.5.

Attaching Connectors

Attach the communications cable fitted with a connector to the connector of the Connector Terminal.

- Note**
1. The direction of the connector depends on the Connector Terminal node model. Communications connectors of 8-point and 16-point Connector Terminals lie horizontally, and the communications connectors of 32-point Connector Terminals are positioned vertically. Check the direction of the connector carefully before inserting it.
 2. Check that the communications cables are a sufficient length when connecting to prevent them from being pulled out or bent over. Do not place heavy objects on the cable cord. Doing so may cause the cables to break.

- 1,2,3...**
1. Attach the communications cable connector to the connector of the Connector Terminal as shown in the following figure.
The following example is for the SRT2-V□D□□□□(-1).

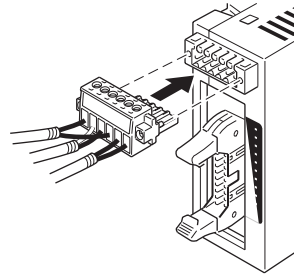

2. Tighten the connector screws to secure the connector to the Connector Terminal. The correct tightening torque is 0.2 to 0.4 N·m.

MIL Connector Wiring and Assembly

Use the procedure below to assemble a cable using the following MIL connectors.

- SRT2-V□D16ML (-1): XG4M-2030-T (20-pin MIL Connector)
- SRT2-□D32ML (-1): XG4M-4030-T (40-pin MIL Connector)

The following procedure is an example to assemble the 20-pin MIL Connector. The same procedure will apply if the 40-pin MIL Connector is used.

- 1,2,3...**
1. Using a fine-tipped screwdriver, release both sides of the plug to separate the MIL socket into its contact and cover components. The contact component of the socket has two small hooks on each side. Release both sides of the cover from these hooks one by one, taking care not to forcefully unhook one side only.

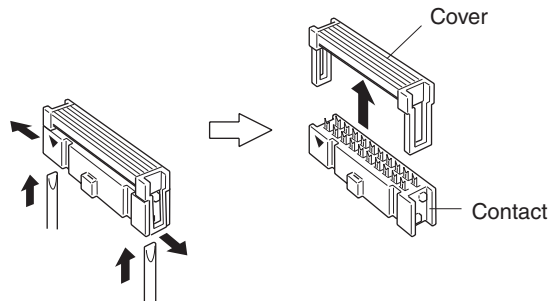

2. Insert the flat cable between the cover and contact components separated in 1 above, then, after making sure that each cable wire is placed in the correct position on the contact component, lock the cover and contact components together. Use a vise or similar tool to press the components together

firmly until the hooks engage.

The following cables can be used with MIL connectors.

- 1.27-mm-pitch flat cable AWG28 (7-wire twisted cable)
- UL2651 (standard cable)
- UL20012 (fabric cable)
- UL20028 (color-coded cable)

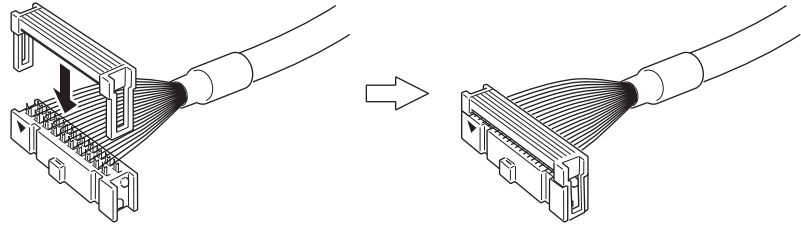

3. If necessary, fold the cable back over as shown and lock on a reinforcing clip.

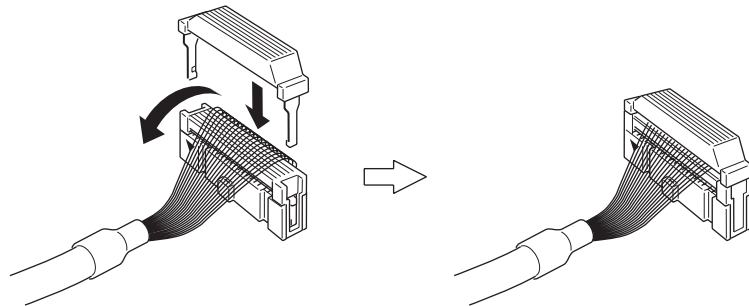

4. Insert the newly assembled MIL connector into the Connector Terminal.

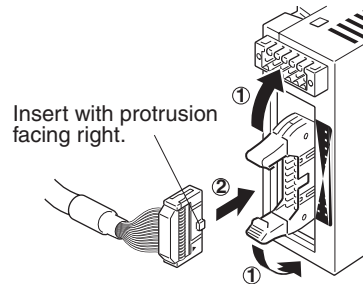

5-3 Remote I/O Modules

5-3-1 SRT□-□D16P Remote I/O Modules

Specifications

The following tables show the ratings and I/O specifications for the SRT□-□D16P.

Ratings

Item	Specification	
Models	SRT1-ID16P SRT2-ID16P	SRT1-OD16P SRT2-OD16P
I/O points	16 input points	16 output points
Internal I/O circuit common	NPN (+ common)	NPN (– common)
Mounting method	PCB mounting with I/O terminals soldered	
Communications mode	SRT1-□D16P: High-speed communications mode SRT2-□D16P: High-speed Communications Mode or Long-distance Communications Mode	
Power supply type	---	
Communications power supply voltage	20.4 to 26.4 V DC	
I/O power supply voltage	24 V DC $+10\%$ / -15%	
Current consumption (See note.)	60 mA max.	20 mA max.
Ambient temperature	Operating: 0 to 55°C (with no icing or condensation) Storage: –20 to 65°C (with no icing or condensation)	
Ambient humidity	Operating: 35% to 85% (with no condensation) Storage: 25% to 85% (with no condensation)	
Dielectric strength	500 V AC for 1 minute (1-mA sensing current, between insulated circuits)	
Node number settings	The node number is set on the address terminal. (Set the node number before turning ON the Slave.)	
Weight	35 g max.	

Note The current consumption is the value with all points turned ON excluding the current consumption of the external sensors connected to the Module inputs and the current consumption of the loads connected to the Module outputs.

Characteristics

Item	Specification
5-V output current	20 mA max. (at 5 V \pm 0.5 V)
LED drive current (COMM, ERR)	10 mA max. (5 V DC)
SW carry current (ADR0 to 3, HOLD)	1 mA max.

Input Specifications

Item	Specification
Input current	2 mA max./point
ON delay time	1.5 ms max.
OFF delay time	1.5 ms max.
ON voltage	15 V DC min. (between each input terminal and BS+ terminal)
OFF voltage	5 V DC max. (between each input terminal and BS+ terminal)

Output Specifications

Item	Specification
Rated output current	0.2 A/point, 0.6 A/common
Residual voltage	0.6 V max. (between each output terminal and G terminal at 0.2 A)
Leakage current	0.1 mA max. (between each output terminal and G terminal at 24 V DC)
ON delay time	0.5 ms max.
OFF delay time	1.5 ms max.

Slave Components

The following diagram shows the main components of SRT1-OD16P Remote I/O Modules. The function of these components are described below.

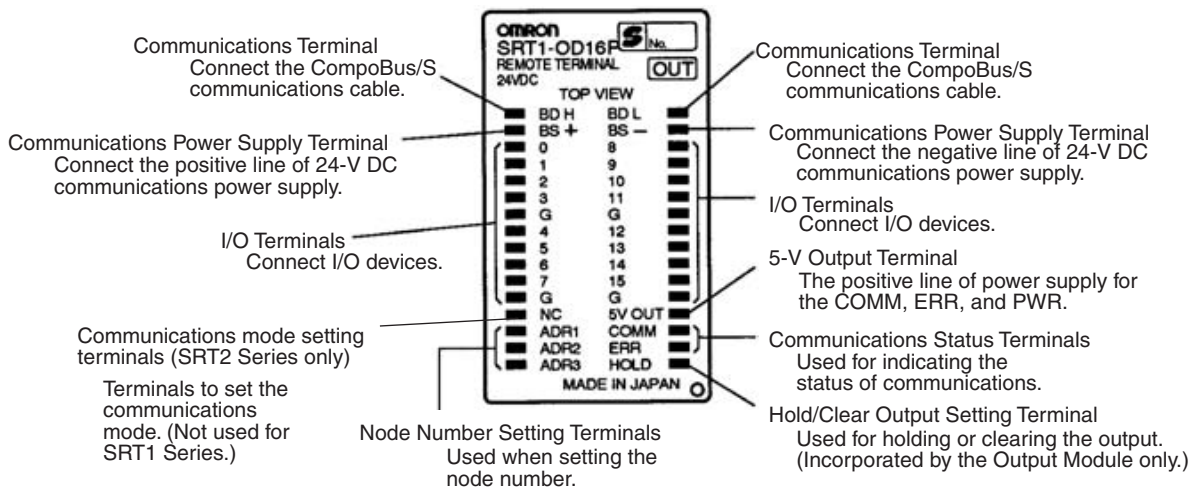

Indicators

The following table shows the meaning of the indicators.

Indicator	Status	Meaning
COMM (yellow)	Low	Normal communications.
	Hi	A communications error has occurred or the Unit is in standby status.
ERR (red)	Low	A communications error has occurred.
	Hi	Normal communications or the Unit is in standby status.

Communications Mode, Node Number and Output HOLD/CLEAR Mode

Set the node number with the NC, ADR1 through ADR3, and hold/clear output setting terminals.

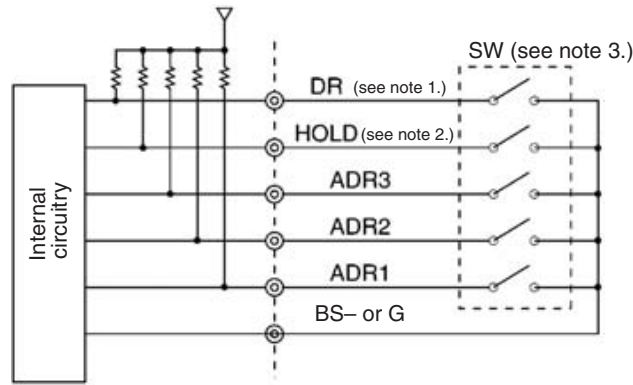

- Note**
1. The DR terminal is not used by the SRT1 Series.
 2. The HOLD terminal is not used by the Input Module.
 3. Low: The input bit is ON. Hi: The input bit is OFF.

Note The HOLD terminal is not used by the Input Module.

Communications Mode Settings (SRT2 Series Only)

The following communications modes are set with the communications mode setting terminal (DR) as shown below.

DR	Communications mode	Communications distance	Communications baud rate	Communications cycle time
Hi	High-speed Communications Mode	100 m max.	750 kbps	0.5 or 0.8 ms
Low	Long-distance Communications Mode	500 m max.	93.75 kbps	4.0 or 6.0 ms

Communications mode settings are possible for SRT2-series Slaves only. SRT1-series Slaves are always in high-speed communications mode.

Note Make sure that the communications mode of the Slave is the same as that of the Master Unit. If the communications modes are not the same, normal communications with the Master Unit will not be possible. The operating status of the Slave can be verified with LED indicators. The COMM terminal corresponds to the COM indicator and ERR terminal corresponds to the ERR indicator.

Node Number Settings

Set the node number with terminals ADR1 through ADR3, as shown in the following table.

Node number	ADR3 (8)	ADR2 (4)	ADR1 (2)
0	Hi	Hi	Hi
2	Hi	Hi	Low
4	Hi	Low	Hi
6	Hi	Low	Low
8	Low	Hi	Hi
10	Low	Hi	Low
12	Low	Low	Hi
14	Low	Low	Low

Note 1. Low: The input bit is ON. Hi: The input bit is OFF.

2. The node number should be an even number.
3. The terminals are pulled up to the 5-V line internally.

Note The actual node number setting range depends on the type of PLC in which the Master is mounted as well as the Master's settings. Refer to *2-1 Communications Specifications* for details.

Hold/Clear Output Setting for Communications Errors (Output Module Only)

The HOLD terminal is used to set the output data status when a communications error occurs, as shown in the following table.

HOLD	Setting
Hi	Output status is cleared when a communications error occurs.
Low	Output status is maintained.

Internal Circuits

The following diagram shows the internal circuits for the SRT□-ID16P (16 inputs).

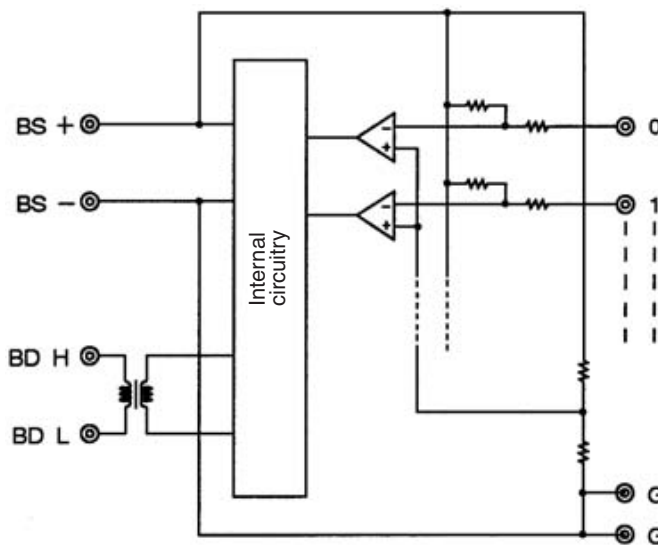

The following diagram shows the internal circuits for the SRT□-OD16P (16 outputs).

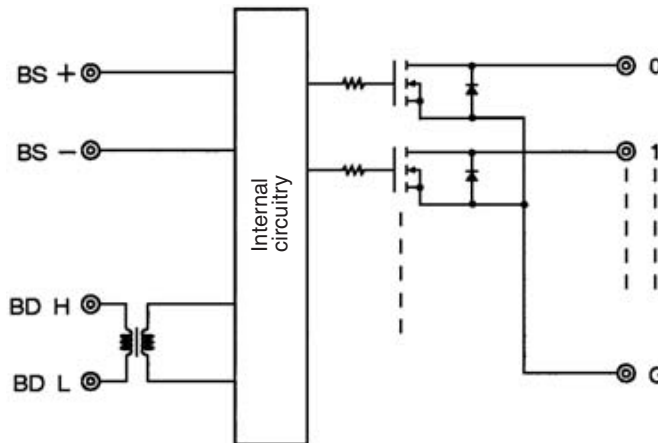

External Connections

The following diagram shows the external connections for the SRT□-ID16P (16 inputs).

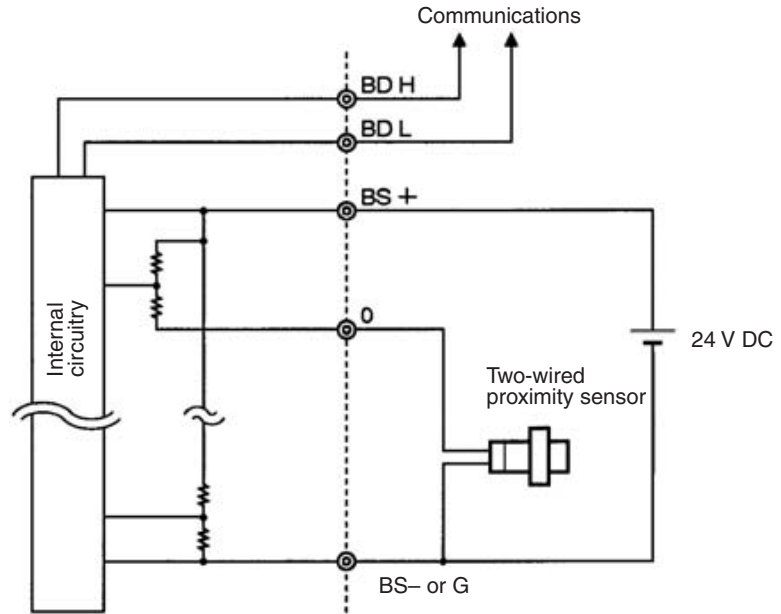

The following diagram shows the external connections for the SRT□-OD16P (16 outputs).

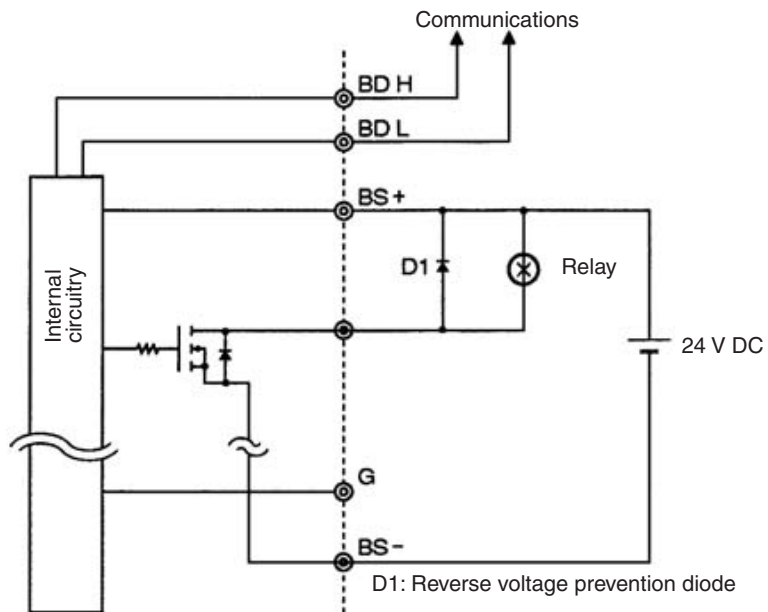

Connecting Communications Status Indicators

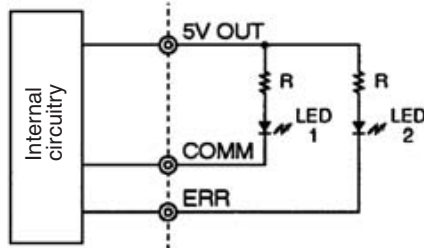

R: LED current limiting resistor
 LED1: LED for COMM
 LED2: LED for ERR

The maximum current for LED1 and LED2 is 10 mA.

The 5-V output terminals have positive power supplies (maximum output current of 20 mA) for the ERR and COMM LEDs. Recommended LED colors are red for ERR and yellow for COMM.

Precautions on Inner-layer Pattern Connecting BD H and BD L Terminals

The pattern connecting terminals BD H and BD L should be as short and as straight as possible. The following precautions should also be observed.

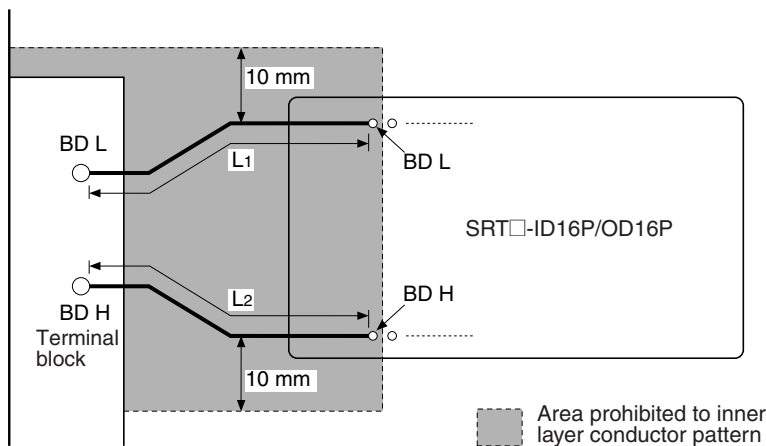

- Conductor Pattern Length**
 The length of the conductors in the pattern connecting the BD L and BD H terminals of the terminal block to those of either SRT-ID16P or SRT-OD16P (L_1, L_2) must satisfy the following conditions.
 $L_1 + L_2 \leq 10 \text{ cm}$
 $L_1 \approx L_2$ (Within ratio of 1.5)
- Conductor Pattern Width**
 The width of the conductor in the pattern connecting the BD L and BD H terminals of the terminal block to those of either SRT-ID16P or SRT-OD16P must be sufficient to carry a current of 250 mA DC, and must also not exceed 0.3 mm (0.3 mm recommended).
- Area Prohibited to Inner Layer Conductor Pattern**
 Do not create another conductor pattern within 10 mm of the pattern connecting the BD L and BD H terminals of the terminal block to those of either SRT-ID16P or SRT-OD16P.

Precautions on Crossing Conductors

When it is necessary for the conductors of the pattern connecting the BD L and BD H terminals of the terminal block to those of either SRT-ID16P or SRT-OD16P to cross, be sure to create one end on the soldered surface of the circuit board, and make the conductors cross between the terminal block and the SRT-ID16P or SRT-OD16P.

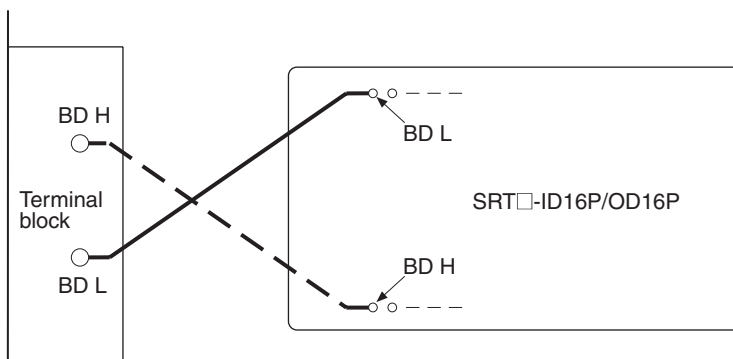

Precautions on Bending Conductor Pattern

When it is necessary for the conductors of the pattern connecting the BD L and BD H terminals of the terminal block to those of either SRT□-ID16P or SRT□-OD16P to change direction, make sure the direction does not veer at a right angle. Keep the direction change within 45°.

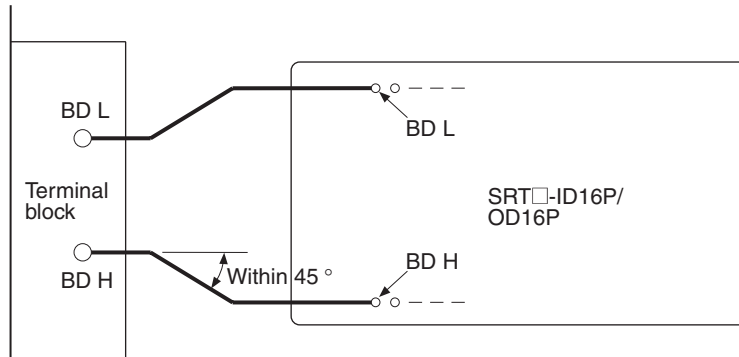

Noise Protection Circuit

Add the following protection circuit if noise is generated from the power supply, input section, or output section.

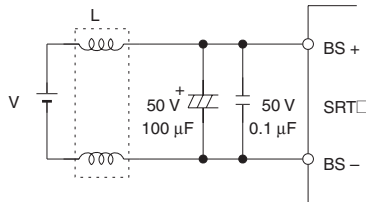
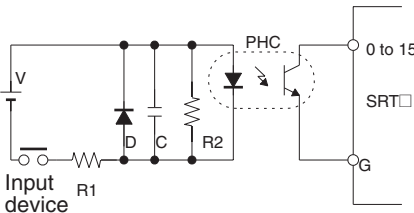
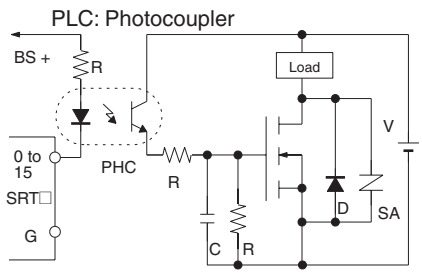
Power supply noise protection circuit	Input section noise protection circuit	Output section noise protection circuit
 <p>L: Coil for the common mode (100 µH min.) Install the coil near the SRT□.</p> <p>V: 24 V DC (Even if a separate power supply is used, the same kind of protection is recommended.)</p>	 <p>R1: Resistor for limiting photocoupler input current D: Photocoupler protection diode C: Noise absorption condenser R2: Resistor for limiting operating level PHC: Photocoupler V: DC power supply</p> <p>Recommended circuit example: R1: 2.7 kΩ; 1/2 W R2: 390 Ω; 1/4 W C: 50 V; 0.1 µF min. (However, these are only examples and are not guaranteed values. Construct the circuit in accordance with the characteristics of the input device to be connected.)</p>	 <p>C: 0.1 µF min. R: Limiting resistor SA: Varistor D: Back-electromotive force protection diode PHS: Photo coupler V: DC power supply</p>

Note

1. Mounting and PCB Cleaning:

- If a soldering iron is used to solder the circuit, make sure that the circuit is soldered within 3 s at 280 to 300°C.
- If a soldering tub is used to solder the circuit, make sure that the circuit is soldered within 5 s at 260°C maximum.
- Do not pass through a reflow furnace. If it is necessary to pass through a reflow furnace, after reflow processing manually apply soldering only to the main parts.
- Do not apply strong acid or alkali solvent to clean the flux. Also, do not apply ultrasonic cleaning.

2. NC Terminal:

- The NC terminal is used internally. Therefore, do not connect anything to the NC terminal.

Inner-layer Pattern for Noise Protection

When adding a noise protection circuit to the input or output section, create inner-layer patterns as follows:

- There must be at least 2.54 mm between the adjacent inner-layer patterns of the external and internal circuits.
- The inner-layer pattern of the external circuit must be kept at least 10 mm from each terminal of the SRT□-ID16P or SRT□-OD16P,

No parts must be mounted on the soldered surfaces around the SRT□-ID16P or SRT□-OD16P.

Example: SRT1-ID16P

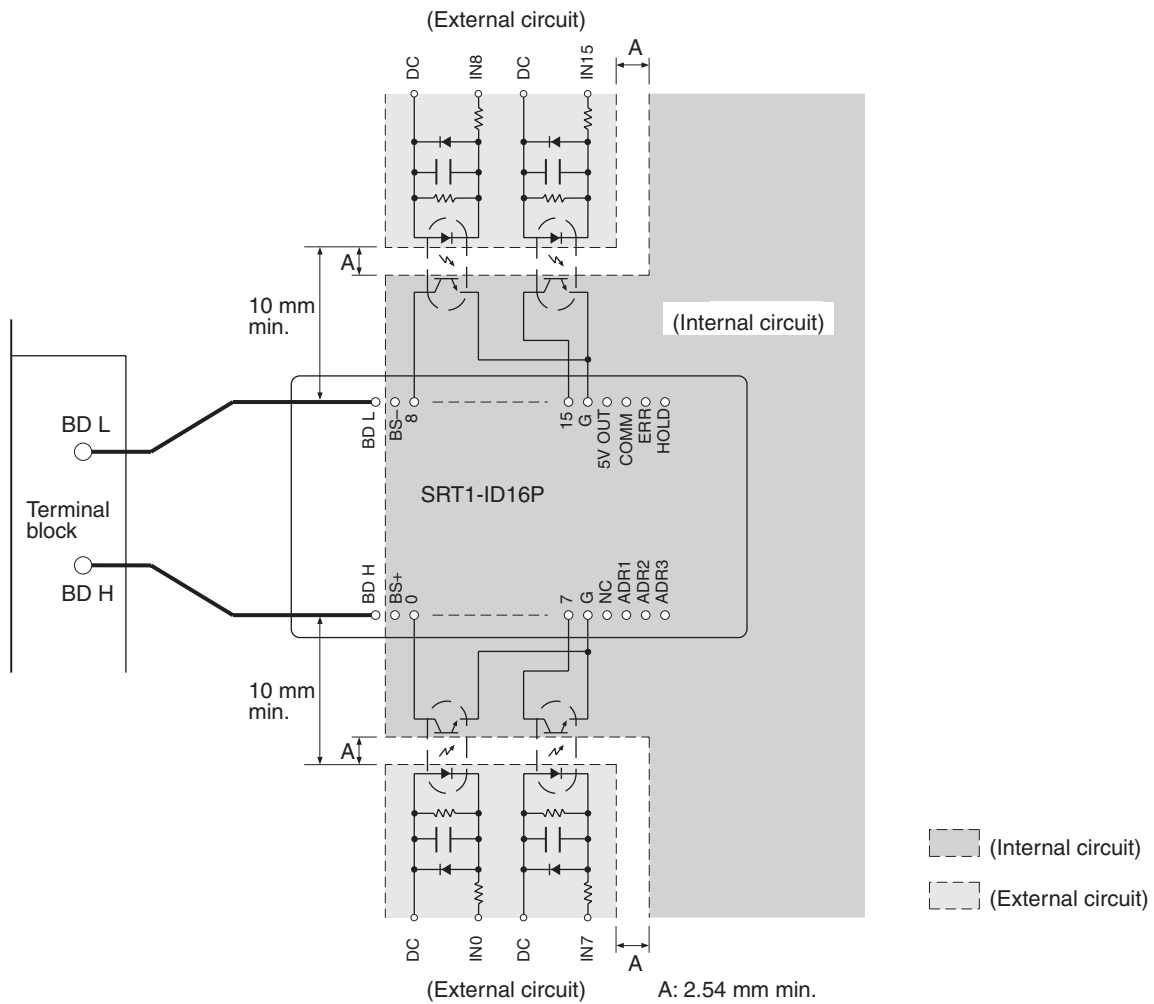

**SRT□-ID16P/OD16P
Dimensions**

The following diagram shows the dimensions for the SRT□-ID16P/OD16P. All dimensions are in mm.

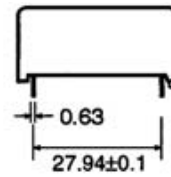
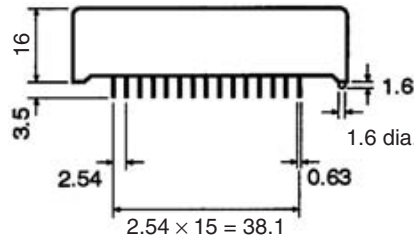

PCB Dimensions (Top View)

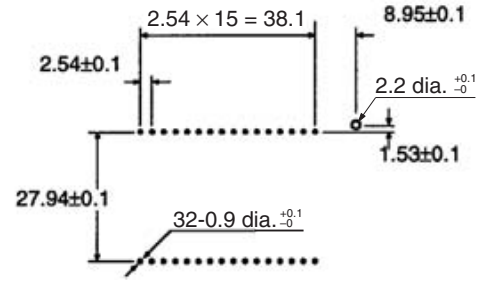
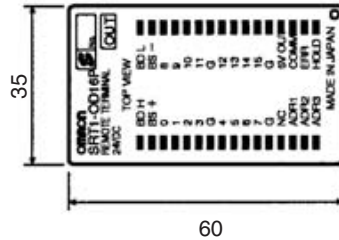

No cumulative tolerance allowed.

5-4 Water-resistant Terminals

5-4-1 SRT2-ID□□CL (-1) Water-resistant Terminals with 4 or 8 Transistor Inputs

Specifications

The following tables show the ratings and input specifications for the SRT2-ID□□CL (-1).

Ratings

Item	Specification
Models	SRT2-ID04CL, SRT2-ID04CL-1, SRT2-ID08CL, SRT2-ID08CL-1
I/O points	SRT2-ID04CL: 4 input points (NPN) SRT2-ID04CL-1: 4 input points (PNP) SRT2-ID08CL: 8 input points (NPN) SRT2-ID08CL-1: 8 input points (PNP)
Connection	<p>Communications</p> <p>XS2C-D4S7: Connector Socket Assembly (female) (Crimp terminals/Solder terminals)</p> <p>Inputs</p> <p>XS2G-D4□□: Connector Plug Assembly (male) (Crimp terminals/Solder terminals)</p> <p>XS2H-D421-□□□: Connector with cable (male plug on one end)</p> <p>XS2W-D42□-□□□: Connectors with cable (Socket/Plug on both ends)</p> <p>I/O power</p> <p>XS2C-D4□□: Connector Socket Assembly (female) (Crimp terminals/Solder terminals)</p> <p>XS2F-D42□-□80-A: Connector with cable (female socket on one end)</p>
Power supply type	Multiple power supplies
Communications power supply voltage	14 to 26.4 V DC (Power can be supplied from the communications cable)

Item	Specification
I/O power supply voltage	20.4 to 26.4 V DC (24 V DC $+10\%/_{-15\%}$)
I/O power supply current	2.4 A max.
Current consumption (See note.)	Communications power: 50 mA max. at 24 V DC
Noise immunity	1.5 kVp-p with a pulse width of 0.1 to 1 μ s and a rise time of 1 ns (tested with impulse noise simulator)
Vibration resistance	10 to 150 Hz, 0.7-mm double amplitude or 50 m/s ²
Shock resistance	150 m/s ²
Dielectric strength	500 V AC (between insulated circuits)
Insulation resistance	20 M Ω min. (between insulated circuits)
Ambient temperature	Operating: -10 to 55°C (with no icing or condensation) Storage: -25 to 65°C (with no icing or condensation)
Ambient humidity	Operating: 25% to 85% (with no condensation) Storage: 25% to 85% (with no condensation)
Operating environment	No corrosive gases
Enclosure rating	IP67
Mounting method	M5 screws
Terminal strength	100N
Node number settings	The node number is set on a rotary switch. (Set the node number before turning ON the Slave.)
Weight	SRT2-ID04CL (-1): 180 g max. SRT2-ID08CL (-1): 240 g max.

Note This is the current consumption when all the maximum simultaneous input points are ON, excluding the current consumption of external sensors.

Input Specifications

Item	Specifications
Input current	6 mA max./point at 24 V DC 3 mA min./point at 17 V DC
ON delay time	1.5 ms max.
OFF delay time	1.5 ms max.
ON voltage	ID04CL/ID08CL: 15 V DC min. (between each input terminal and V) ID04CL-1/ID08CL-1: 15 V DC (between each input terminal and G)
OFF voltage	ID04CL/ID08CL: 5 V DC max. (between each input terminal and V) ID04CL-1/ID08CL-1: 5 V DC max. (between each input terminal and G)
OFF current	1 mA max.
Insulation method	Photocoupler
Input indicator	LED (yellow)
Number of circuits	ID04CL (-1): 4 points/single common circuit ID08CL (-1): 8 points/single common circuit

Slave Components

The following diagram shows the main components of the SRT2-ID□□CL (-□) Water-resistant Terminals with Transistor Inputs. The functions of these components are described below.

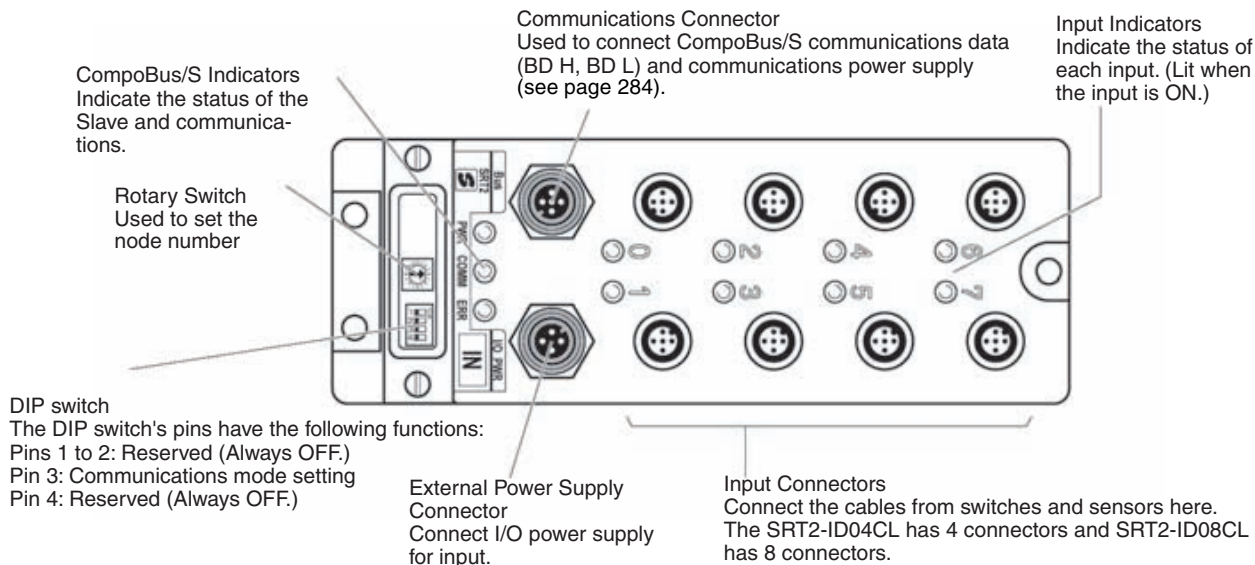

Indicators

The following table shows the meaning of the indicators.

Indicator	Name	Status	Meaning
PWR (green)	Power	ON	The communications power supply is ON.
		OFF	The communications power supply is OFF.
COMM (yellow)	Communica-tions	ON	Normal communications.
		OFF	A communications error has occurred or the Unit is in standby status.
ERR (red)	Communica-tions error	ON	A communications error has occurred.
		OFF	Normal communications or the Unit is in standby status.
IN0 to 3 (4 inputs) IN0 to 7 (8 inputs) (yellow)	Inputs	ON	The corresponding input is ON.
		OFF	The corresponding input is OFF or the Unit is in standby status.

Switch Settings

The rotary switch and the DIP switch are located under the transparent cover.

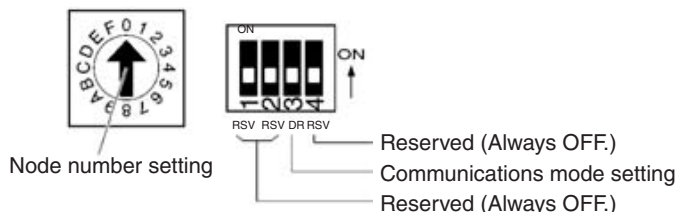

- Note**
1. Always turn OFF the Slave before changing switch settings.
 2. Always set all the reserved pins to OFF, or otherwise the Unit may not operate normally.

Node Number Settings

Set the node number in hexadecimal with the rotary switch as shown in the following table.

Node number	Setting (Hex)	Node number	Setting (Hex)
0	0	8	8
1	1	9	9
2	2	10	A
3	3	11	B
4	4	12	C
5	5	13	D
6	6	14	E
7	7	15	F

Note The possible range of node numbers varies with the type of Master and settings in the Master. Refer to 2-1 Communications Specifications for details.

Communications Mode Settings

The following communications modes are set with pin 3 of the DIP.

Pin 3	Communications mode	Communications distance	Communications baud rate	Communications cycle time
OFF	High-speed Communications Mode	100 m max.	750 kbps	0.5 or 0.8 ms
ON	Long-distance Communications Mode	500 m max.	93.75 kbps	4.0 or 6.0 ms

Note Make sure that the communications mode of the Slave is the same as that of the Master Unit. If the communications modes are not the same, normal communications with the Master Unit will not be possible. The operating status of the Slave can be verified with LED indicators. Refer to 6-5-1 Indicators.

Internal Circuits

SRT2-ID04CL, SRT2-ID08CL

The following diagram shows the internal circuits for the SRT2-ID04-CL and SRT2-ID08CL.

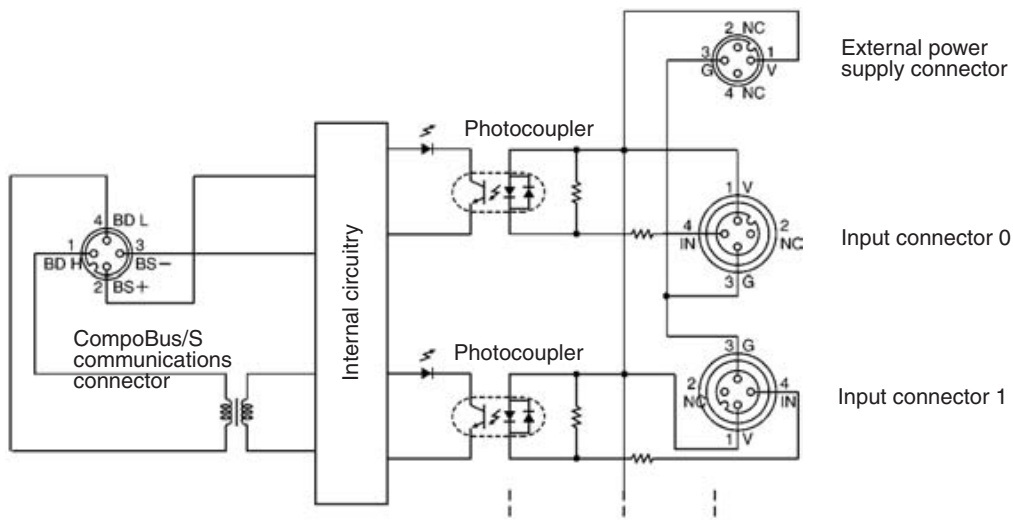

SRT2-ID04CL-1, SRT2-ID08CL-1

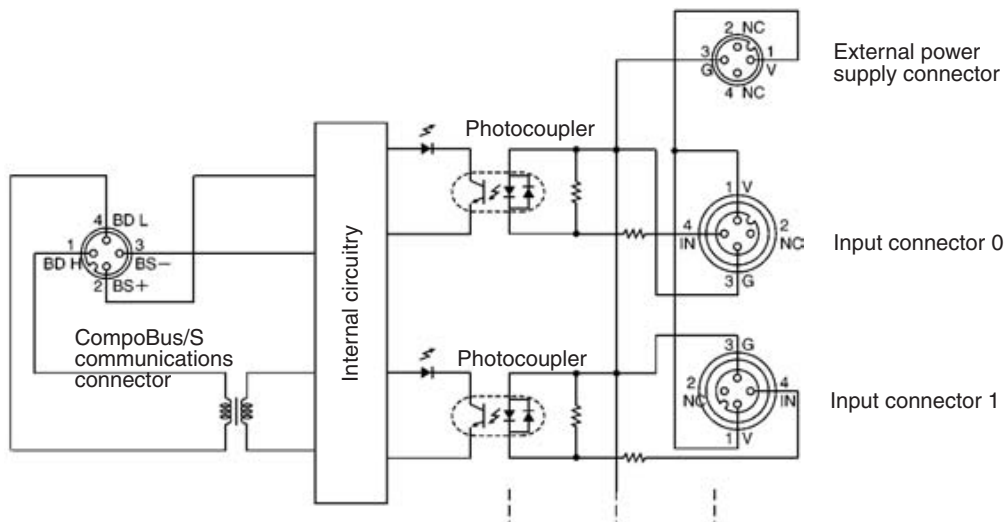

Wiring

SRT2-ID04CL

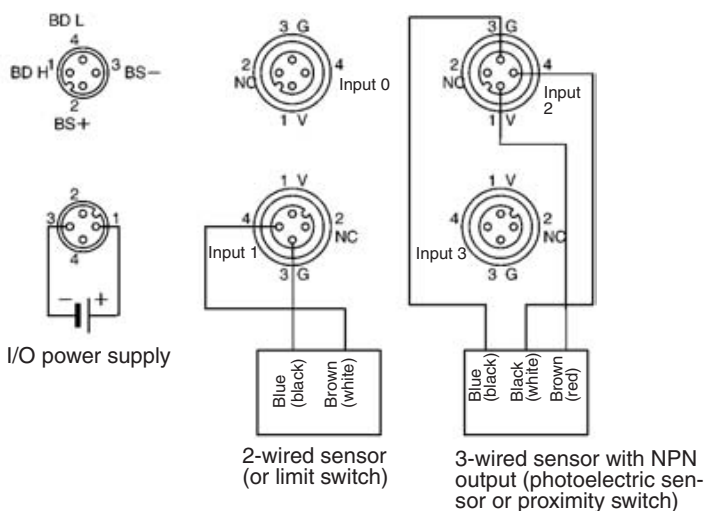

SRT2-ID04CL-1

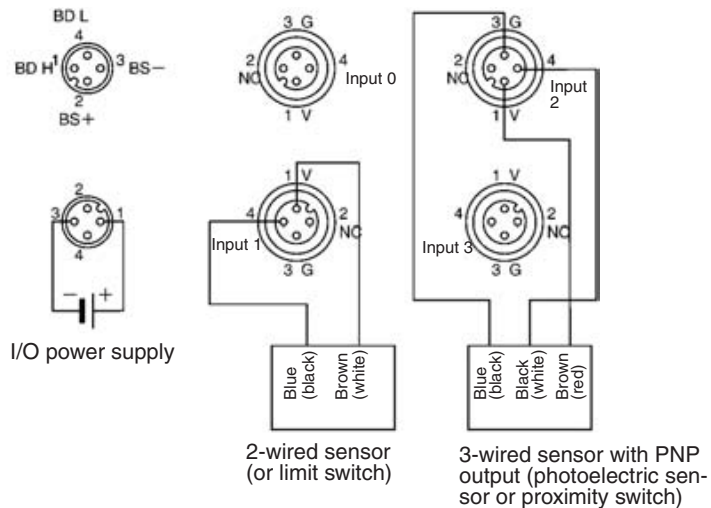

SRT2-ID08CL

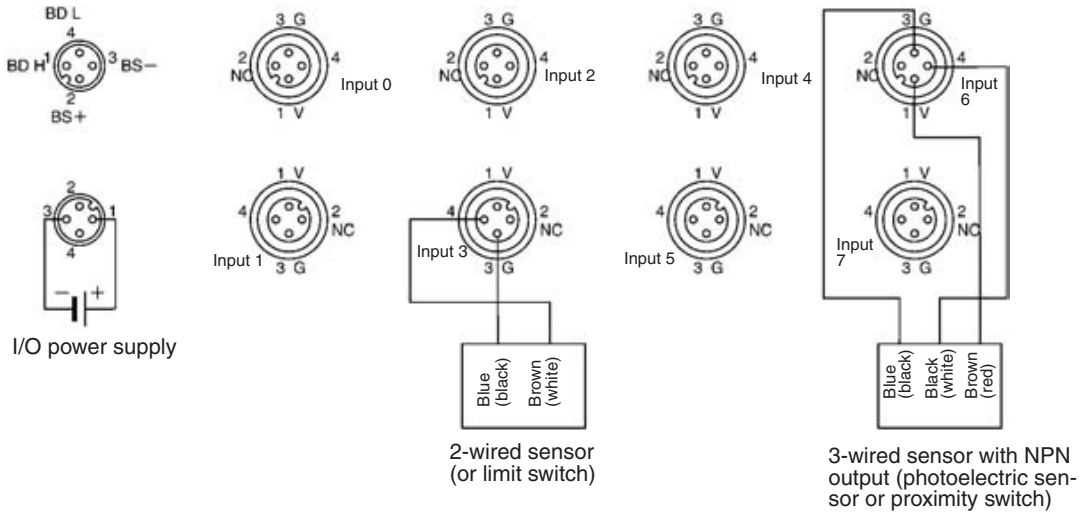

SRT2-ID08CL-1

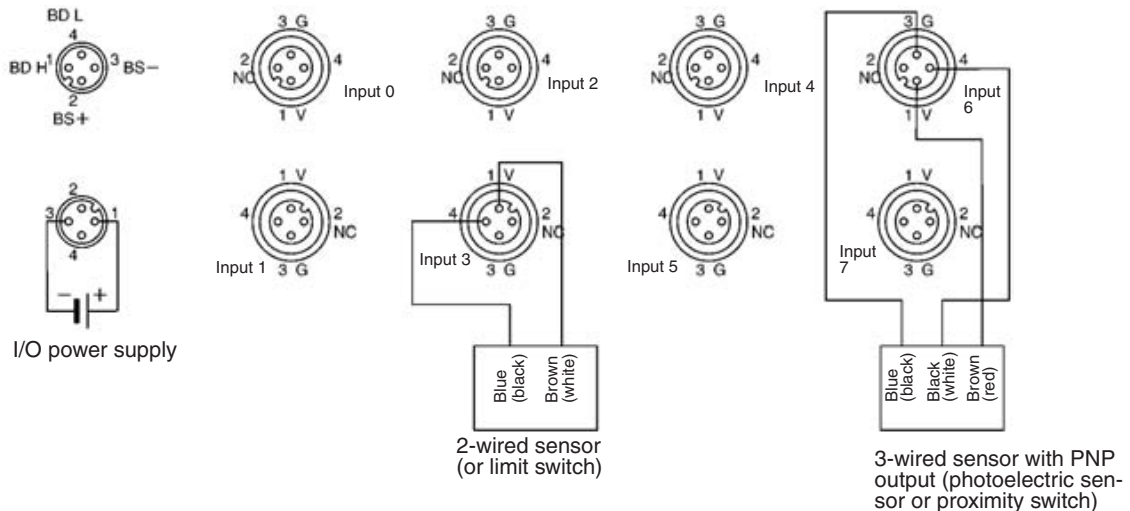

- Note**
1. The V terminals are all connected internally, as are the G terminals. Input connectors G and V can be used to supply power to sensors, provided that the total current flow through these connectors is less than 2.4 A when input power supply is provided to the external power supply connector. Connect external power supply if the total current flow is 2.4 A or more.
 2. Wire colors have been changed. Colors in parentheses are the old wire colors.

Dimensions

SRT2-ID04CL, SRT2-ID04CL-1

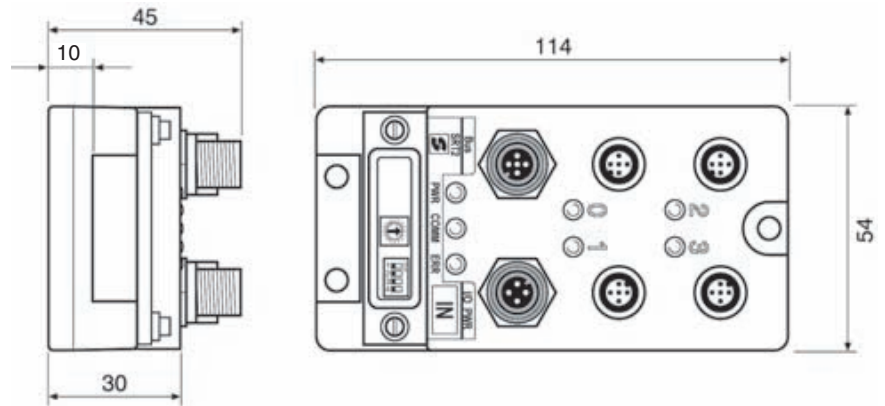

Mounting dimensions

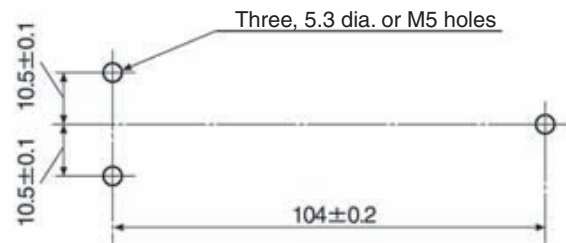

(Unit: mm)

SRT2-ID08CL, SRT2-ID08CL-1

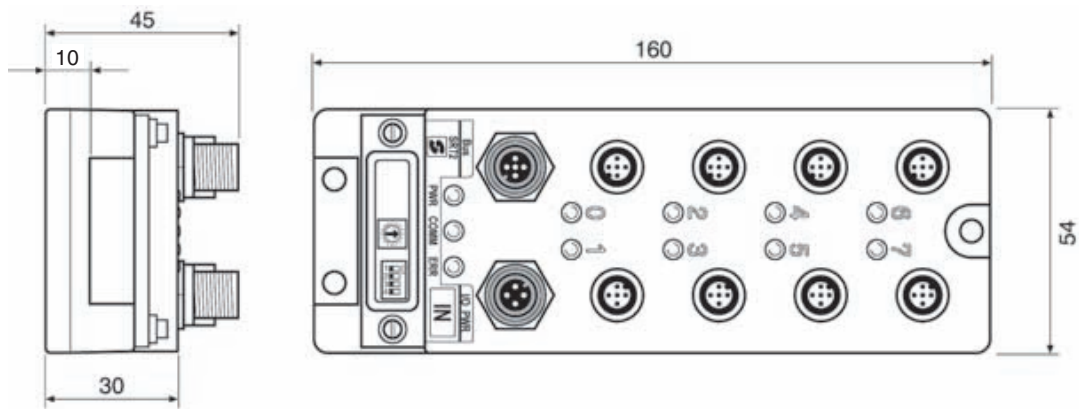

Mounting dimensions

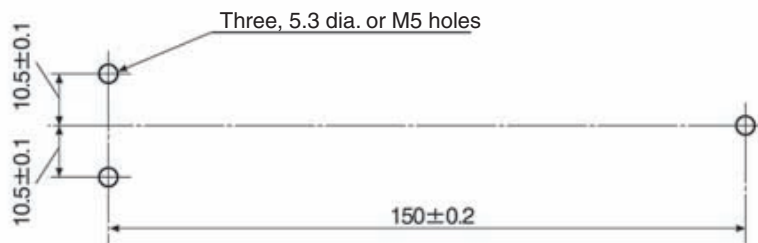

(Unit: mm)

Communications Cable, I/O Power Supply, and I/O Wiring

Communications Cable Wiring

Use the following connectors to connect the communications cable.

Connectors

Type	Model
Connector Socket Assembly (female) (Crimp terminals/Solder terminals)	XS2C-D4S7
Connector Plug Assembly (male) (Crimp terminals/Solder terminals)	XS2G-D4S7
T-joint	XS2R-D427-5

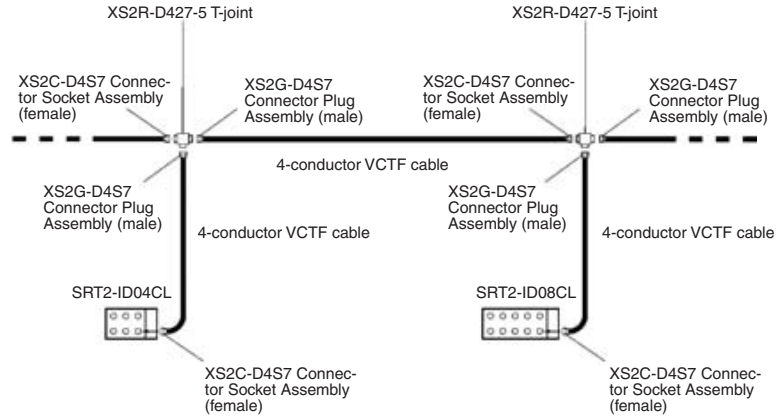

Note Tighten the connector securely by hand to a torque of 0.39 to 0.49 N·m. If the connector is not tightened securely, the connector will be loosened or cannot maintain the enclosure rating. Do not tighten the connector with tools such as pliers, or otherwise the connector may be broken.

I/O Power Supply Wiring

Use the following XS2-series Round Water-resistant Connectors to wire I/O power supply.

Connectors

Type	Model
Connectors with Cable (Socket and Plug)	XS2W-D42□-□81-□
Connector with Cable (Female socket on one end)	XS2F-D42□-□80-□
T-joint	XS2R-D427-5

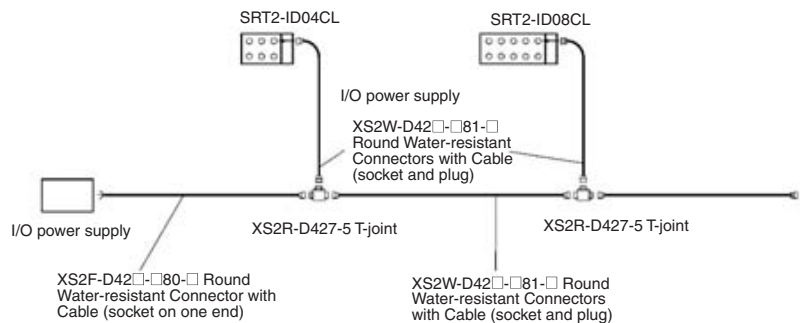

- Note**
1. Tighten the connector securely by hand to a torque of 0.39 to 0.49 N·m. If the connector is not tightened securely, the connector will be loosened or cannot maintain the enclosure rating. Do not tighten the connector with tools such as pliers, or otherwise the connector may be broken.
 2. A single I/O power supply can be used for input and output. Input devices may, however, malfunction due to noise generated from output devices. Therefore, it is recommended to use independent I/O power supplies.
 3. Commercial available VCTF cable can be used for I/O power cable, provided that the specifications of the VCTF cable, such as the permissible current and voltage drop, satisfy the conditions.

I/O Wiring

Used the following XS2-series Round Water-resistant Connectors to wire I/O.

Connectors

Type	Model
Connector with Cable (Male plug on one end)	XS2H-D421-□80-A
Connectors with Cable (Socket and plug)	XS2W-D42□-□81-A
Connector Plug Assembly (Male) (Crimp terminals/Solder terminals)	XS2R-D4□□

A sensor with a relay connector can directly connect to the Unit.

When connecting a device, check the pin arrangement of the device with the datasheet.

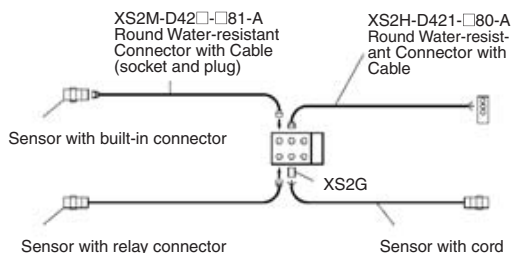

Refer to the Sensor General Catalog for sensors with connectors and Round Water-resistant Connectors (sensor I/O connectors) in detail.

- Note**
1. Tighten the connector securely by hand to a torque of 0.39 to 0.49 N·m. If the connector is not tightened securely, the connector will be loosened or cannot maintain the enclosure rating. Do not tighten the connector with tools such as pliers, or otherwise the connector may be broken.
 2. Attach the XS2Z-12 Water-resistant Cover or XS2Z-15 Dust Cover to unused connectors.



The connector with the Water-resistant Cover will be of IP67 construction. Attach the Water-resistant Cover to the connector and tighten the Water-resistant Cover securely by hand to a torque of 0.39 to 0.49 N·m.

Press the Dust Cover deeply enough to the Dust Cover. The Dust Cover is not of IP67 construction.

- Note**
1. Check that the junction of the contact block and cover is free of external force imposed, or otherwise the IP67 enclosure rating will be lost.
 2. Water-resistant Terminals used as Slaves are of IP67 construction. Do not attempt to use the Water-resistant Terminals for applications where the Water-resistant Terminals are always underwater.
 3. The Unit is a plastic resin mold product. Do not tread on the Unit or put objects on the Unit.

OMRON's 2-wired Proximity Sensors with relay connectors are classified into M1GJ models, which have the IEC pin arrangement, and M1J models, which have the OMRON pin arrangement. The following Water-resistant Terminals are compatible with these different pin arrangements.

2-wired sensor (with relay connector)	Compatible Water-resistant Terminals
IEC pin arrangement (M1GJ model)	SRT2-ID04CL-1 SRT2-ID08CL-1
OMRON pin arrangement (M1J model)	SRT2-ID04CL SRT2-ID08CL

5-4-2 SRT2-OD□□CL (-1) Water-resistant Terminals with 4 or 8 Transistor Outputs

Specifications

The following tables show the ratings and input specifications for the SRT2-OD□□CL (-1).

Ratings

Item	Specification
Models	SRT2-OD04CL, SRT2-OD04CL-1, SRT2-OD08CL, SRT2-OD08CL-1
I/O points	SRT2-OD04CL: 4 output points (NPN) SRT2-OD04CL-1: 4 output points (PNP) SRT2-OD08CL: 8 output points (NPN) SRT2-OD08CL-1: 8 output points (PNP)
Connection	<p>Communications</p> <p>XS2C-D4S7: Connector Socket Assembly (female) (Crimp terminals/Solder terminals)</p> <p>Outputs</p> <p>XS2G-D4□□: Connector Plug Assembly (male) (Crimp terminals/Solder terminals)</p> <p>XS2H-D421-□□□: Connector with cable (male plug on one end)</p> <p>XS2W-D42□-□□□: Connectors with cable (Socket/Plug on both ends)</p> <p>I/O power</p> <p>XS2C-D4□□: Connector Socket Assembly (female) (Crimp terminals/Solder terminals)</p> <p>XS2F-D42□-□80-A: Connector with cable (female socket on one end)</p>
Power supply type	Multiple power supplies
Communications power supply voltage	14 to 26.4 V DC (Power can be supplied from the communications cable)
I/O power supply voltage	20.4 to 26.4 V DC (24 V DC $+10\%$ / -15%)
I/O power supply current	2.4 A max.
Current consumption (See note.)	Communications power: 50 mA max. at 24 V DC
Noise immunity	1.5 kVp-p with a pulse width of 0.1 to 1 μ s and a rise time of 1 ns (tested with impulse noise simulator)

Item	Specification
Vibration resistance	10 to 150 Hz, 0.7-mm double amplitude or 50 m/s ²
Shock resistance	150 m/s ²
Dielectric strength	500 V AC (between insulated circuits)
Insulation resistance	20 MΩ min. (between insulated circuits)
Ambient temperature	Operating: -10 to 55°C (with no icing or condensation) Storage: -25 to 65°C (with no icing or condensation)
Ambient humidity	Operating: 25% to 85% (with no condensation) Storage: 25% to 85% (with no condensation)
Operating environment	No corrosive gases
Enclosure rating	IP67
Mounting method	M5 screws
Terminal strength	100N
Node number settings	The node number is set on a rotary switch. (Set the node number before turning ON the Slave.)
Weight	SRT2-OD04CL (-1): 180 g max. SRT2-OD08CL (-1): 240 g max.

Note This is the current consumption when all the maximum simultaneous output points are ON, excluding the current consumption of external loads.

Output Specifications

Item	Specifications
Output current	OD04CL (-1): 0.3 A/point 1.2 A/common OD08CL (-1): 0.3 A/point 2.4 A/common
Residual voltage	1.2 V max.
Leakage current	0.1 mA max.
ON delay time	0.5 ms max.
OFF delay time	1.5 ms max.
Insulation method	Photocoupler
Output indicator	LED (yellow)
Number of circuits	OD04CL (-1): 4 points/single common circuit OD08CL (-1): 8 points/single common circuit

Slave Components

The following diagram shows the main components of the SRT2-OD□□CL (-□) Water-resistant Terminals with Transistor Outputs. The functions of these components are described below.

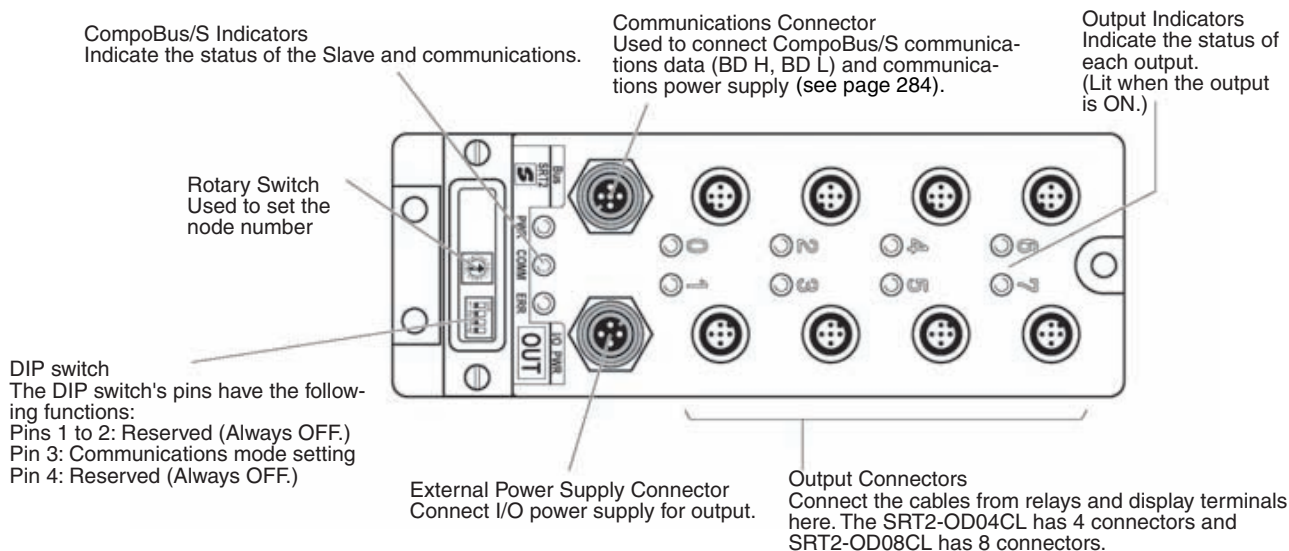

Indicators

The following table shows the meaning of the indicators.

Indicator	Name	Status	Meaning
PWR (green)	Power	ON	The communications power supply is ON.
		OFF	The communications power supply is OFF.
COMM (yellow)	Communi-cations	ON	Normal communications.
		OFF	A communications error has occurred or the Unit is in standby status.
ERR (red)	Communi-cations error	ON	A communications error has occurred.
		OFF	Normal communications or the Unit is in standby status.
OUT0 to 3 (4 outputs) OUT0 to 7 (8 outputs) (yellow)	Output	ON	The corresponding input is ON.
		OFF	The corresponding input is OFF or the Unit is in standby status.

Switch Settings

The rotary switch and the DIP switch are located under the transparent cover.

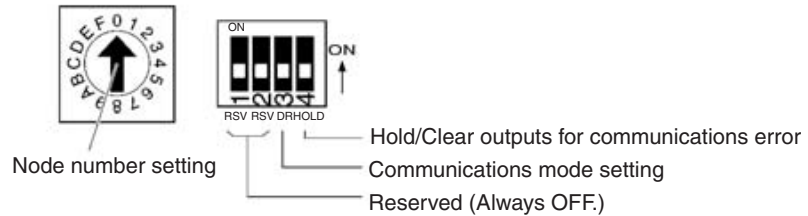

- Note**
1. Always turn OFF the Slave before changing switch settings.
 2. Always set all the reserved pins to OFF, or otherwise the Unit may not operate normally.

Node Number Settings

Set the node number in hexadecimal with the rotary switch as shown in the following table.

Node number	Setting (Hex)	Node number	Setting (Hex)
0	0	8	8
1	1	9	9
2	2	10	A
3	3	11	B
4	4	12	C
5	5	13	D
6	6	14	E
7	7	15	F

Note The possible range of node numbers varies with the type of Master and settings in the Master. Refer to 2-1 Communications Specifications for details.

Communications Mode Settings

The following communications modes are set with pin 3 of the DIP switch as shown below.

Pin 3	Communications mode	Communications distance	Communications baud rate	Communications cycle time
OFF	High-speed Communications Mode	100 m max.	750 kbps	0.5 or 0.8 ms
ON	Long-distance Communications Mode	500 m max.	93.75 kbps	4.0 or 6.0 ms

Note Make sure that the communications mode of the Slave is the same as that of the Master Unit. If the communications modes are not the same, normal communications with the Master Unit will not be possible. The operating status of the Slave can be verified with LED indicators. Refer to 6-5-1 Indicators.

Hold/Clear Outputs for Communications Error

Pin 4 is used to set the output data status when a communications error occurs, as shown in the following table.

Pin 4 (HOLD)	Output setting
OFF	Clear output status.
ON	Maintain output status.

Internal Circuits

SRT2-OD04CL and SRT2-OD08CL

The following diagram shows the internal circuits for the SRT2-OD04CL and SRT2-OD08CL.

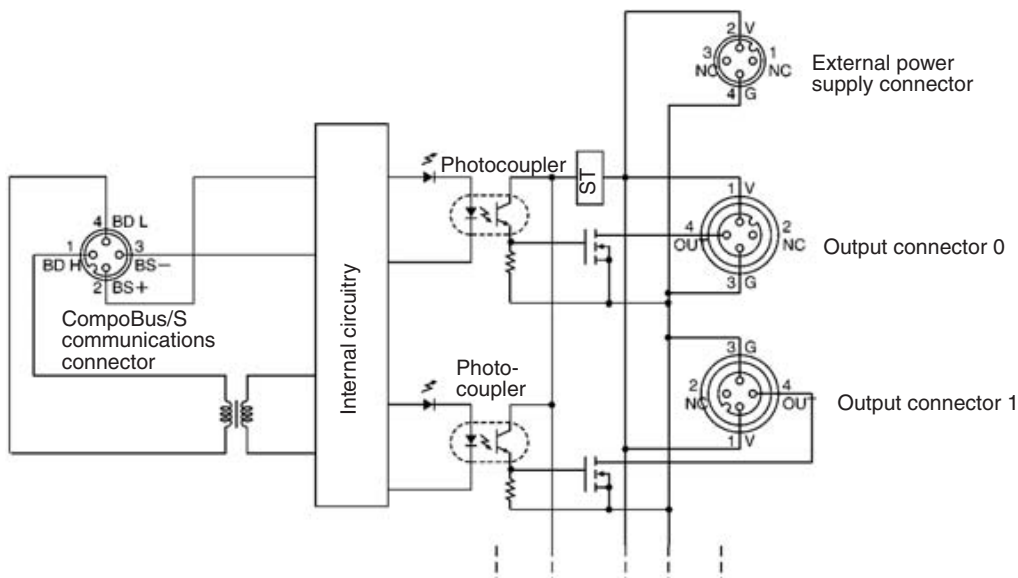

SRT2-OD04CL-1 and SRT2-OD08CL-1

The following diagram shows the internal circuits for the SRT2-OD04CL-1 and SRT2-OD08CL-1.

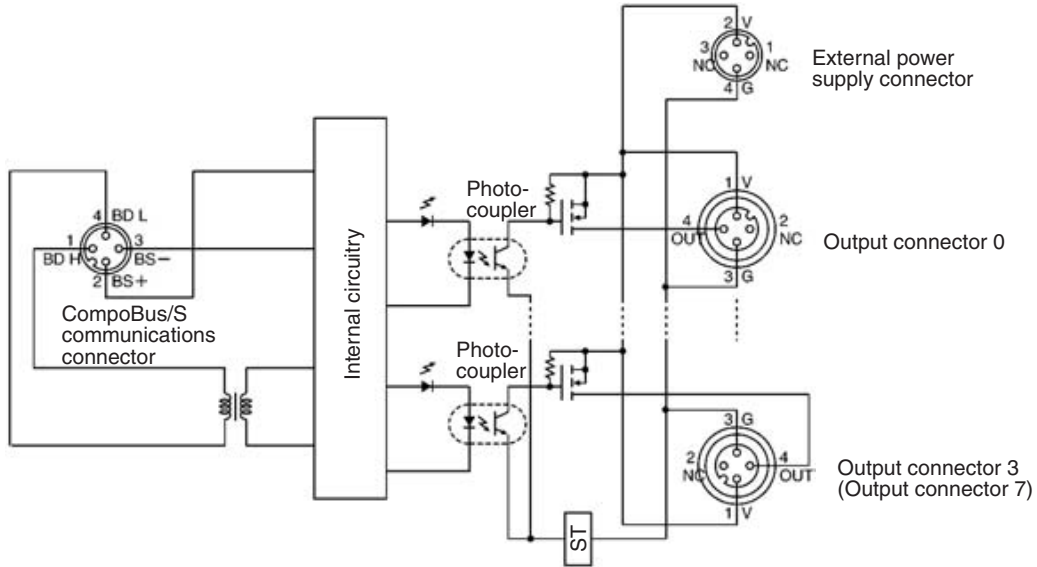

Wiring

SRT2-OD04CL

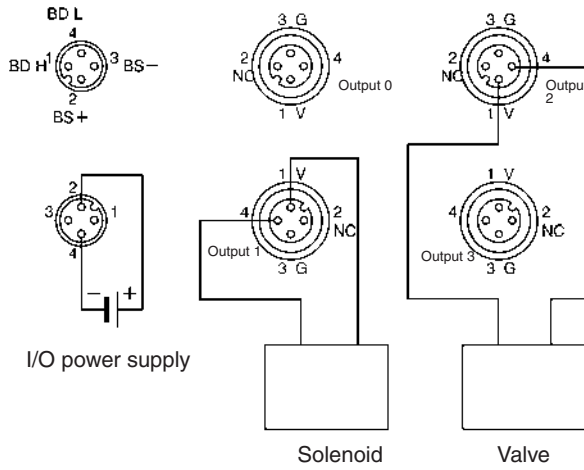

SRT2-OD04CL-1

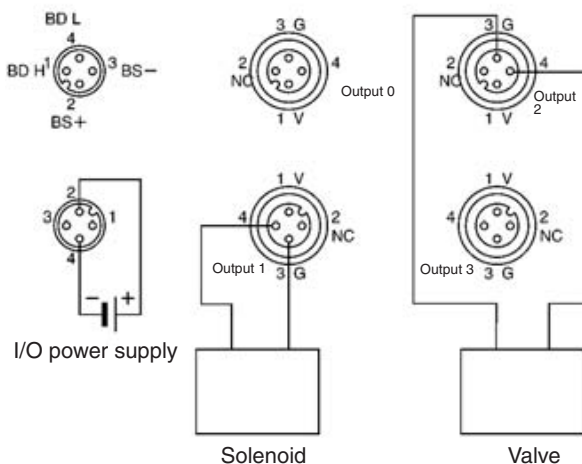

Note The V terminals are all connected internally, as are the G terminals. Output connectors G and V are available to external power supply, provided that the total current flow through these connectors is less than 2.0 A when output power supply is provided to the external power supply connector. Connect external power supply if the total current flow is 2.0 A or more.

SRT2-OD08CL

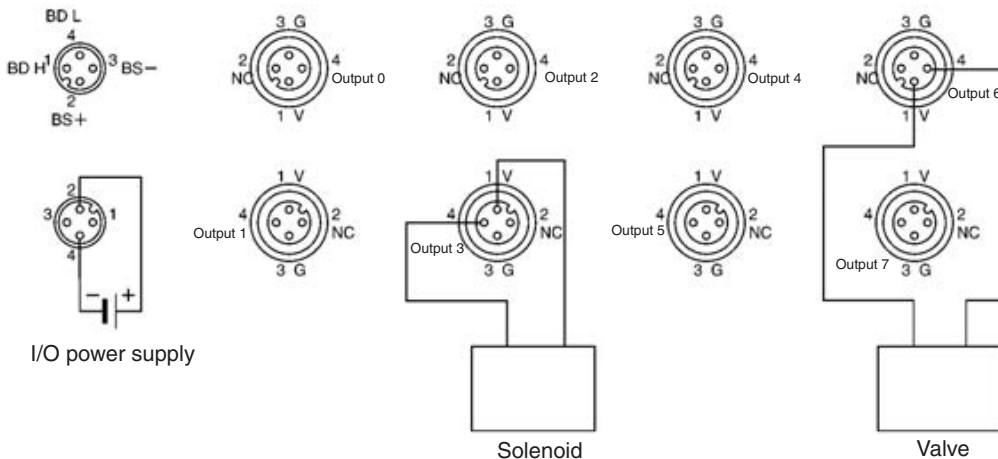

SRT2-OD08CL-1

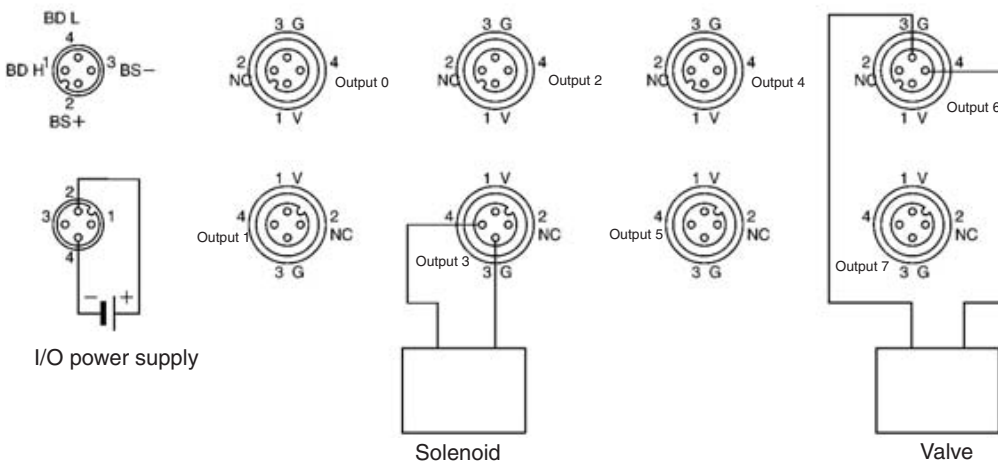

Note The V terminals are all connected internally, as are the G terminals. Output connectors G and V are available to external power supply, provided that the total current flow through these connectors is less than 2.4 A when output power supply is provided to the external power supply connector. Connect external power supply if the total current flow is 2.4 A or more.

Dimensions

SRT2-OD04CL, SRT2-OD04CL-1

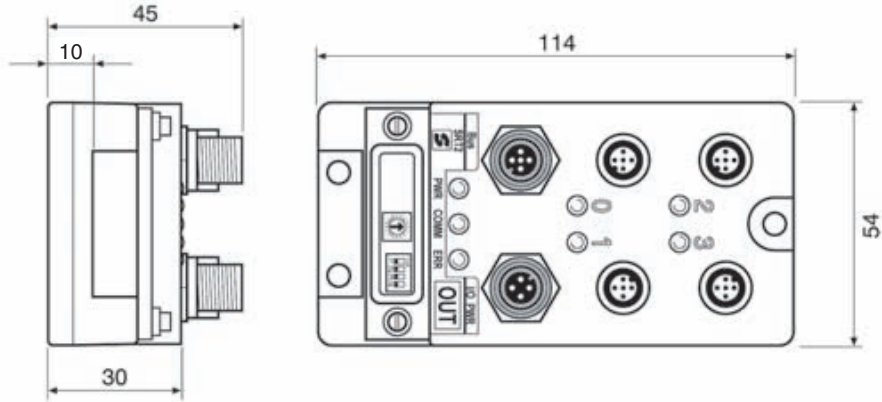

Mounting dimensions

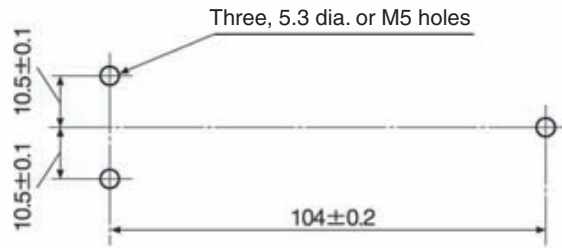

(Unit: mm)

SRT2-OD08CL, SRT2-OD08CL-1

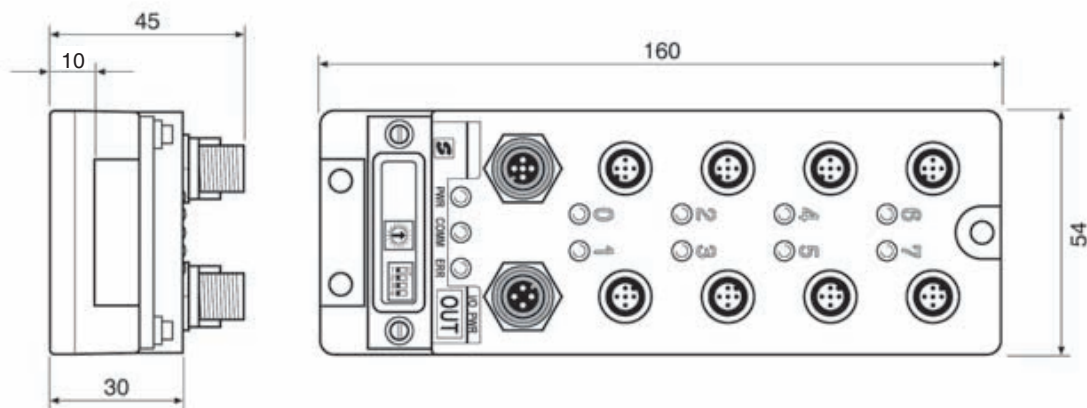

Mounting dimensions

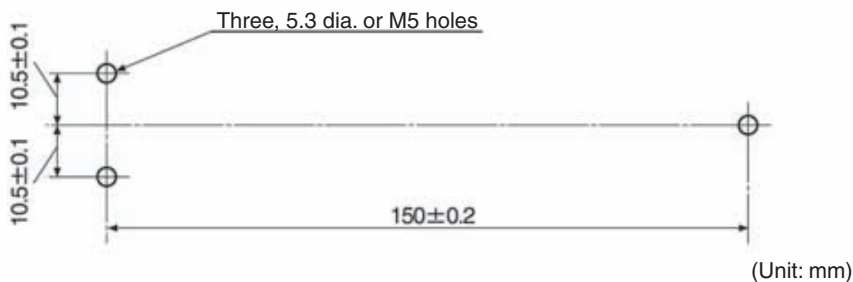

Note For details on the communications cable, I/O power supply, and I/O wiring, refer to *Communications Cable, I/O Power Supply, and I/O Wiring* on page 275 under 5-4-1 SRT2-ID□□CL (-1) Water-resistant Terminals with 4 or 8 Transistor Inputs.

5-4-3 Shielded Connector Wiring and Assembly

Connect external I/O power supply and I/O Units to Water-resistant Terminals through Shielded Connector (round Water-resistant connectors). Water-resistant Terminals has a male plug for the external power supply connector and a female socket for the I/O connector. Select ones from the following XS2-series Round Water-resistant Connectors according to the I/O power supply method or the I/O Unit.

• Connectors for External Power Supply

Connector type	Model
Round Water-resistant Connectors with Cable (socket and plug)	XS2W-D42□-□81-□
Round Water-resistant Connector with Cable (socket on one end)	XS2F-D42□-□80-□
Connector Socket Assembly (female) (Crimp terminals/Solder terminals)	XS2C-D4□□

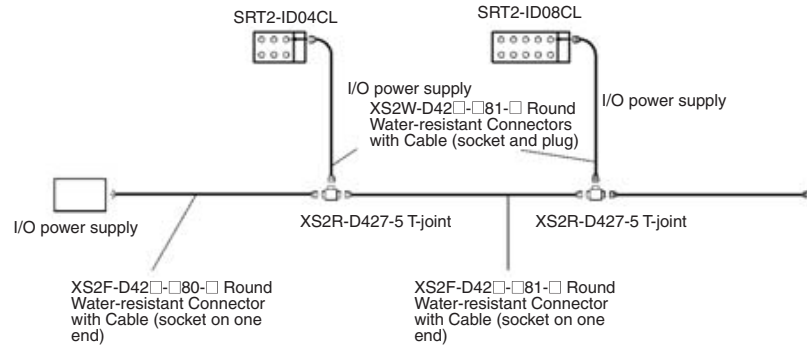

• I/O Connectors

Connector type	Model
Connector with cable (male plug on one end)	XS2H-D421-□80-A
Round Water-resistant Connectors with Cable (socket and plug)	XS2W-D42□-□81-A
Connector Socket Assembly (female) (Crimp terminals/Solder terminals)	XS2G-D4□

The sensor with a relay connector can directly connect to the Unit.

When connecting a device, check the pin arrangement of the device with the datasheet.

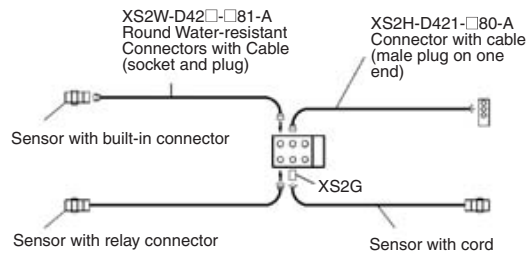

Press the cable connector to the terminal connector until the cable connector comes in contact with the bottom end of the cable connector. Tighten the connector screws to the specified tightening torque (0.39 to 0.49 N·m).

- ⚠ **Caution** Tighten the connector securely by hand to a torque of 0.39 to 0.49 N·m. If the connector is not tightened securely, the connector will be loosened or cannot keep the enclosure rating. Do not tighten the connector with tools such as pliers, or otherwise the connector may be broken.
- ⚠ **Caution** Connectors vary in direction. Check the direction before inserting the connector.
- ⚠ **Caution** Do not pull or bend the cable. Provide some margin when laying the cable. Check that the cable is free of heavy objects, or otherwise the cable may be broken.

- Note**
1. A single I/O power supply can be used for input and output. Input devices may, however, malfunction due to noise generated from output devices. Therefore, it is recommended to use independent I/O power supplies.
 2. Refer to the *Sensor Catalog* for sensors with connectors and Round Water-resistant Connectors (sensor I/O connectors) in detail.

Round Communications Connector to Water-resistant Terminals or T-joints

The communications cable connects to Water-resistant Terminals or T-joints through a round communications connector. Press the cable connector to the terminal or joint connector until the cable connector comes in contact with the bottom end of the cable connector. Tighten the connector screws to the specified tightening torque (0.39 to 0.49 N·m).

 **Caution** The connector direction varies with the type of Connector Terminal. Check the connecting direction before inserting the connector.

 **Caution** Do not pull or bend the communications cable. Provide some margin when laying the communications cable. Check that the communications cable is free of heavy objects, or otherwise the cable may be broken.

Shielded Terminator Connection

The Shielded Terminator has round communications connector (or shielded connector). Connect the Shield Terminator to T-joints or the round communications connectors of communications cable. Press the cable connector to the terminal or joint connector until the cable connector comes in contact with the bottom end of the cable connector. Tighten the connector screws to the specified tightening torque (0.39 to 0.49 N·m).

 **Caution** The connector direction varies with the type of Connector Terminal. Check the connecting direction before inserting the connector.

5-5 Sensor Terminals

5-5-1 SRT□-□D08S Sensor Terminals with 8 Transistor Inputs or 4 Transistor Inputs and 4 Transistor Outputs

Specifications

The following tables show the ratings and I/O specifications for the SRT□-□D08S

Ratings

Item	Specification
Models	SRT1-ID08S SRT1-ND08S SRT2-ID08S SRT2-ND08S
I/O points	SRT□-ID08S: 8 input points SRT□-ND08S: 4 input and 4 output points
Communications mode	SRT1-□D08S: High-speed Communications Mode SRT2-□D08S: High-speed Communications Mode or Long-distance Communications Mode
Power supply type	Network power supply
Communications power supply voltage	14 to 26.4 V DC (see note 1) (Power can be supplied from the communications cable)
Current consumption (see note 2)	Communications: 50 mA max. at 24 V DC
Noise immunity	±1.5 kVp-p with a pulse width of 0.1 to 1 μs and a rise time of 1 ns (via impulse noise simulator)
Vibration resistance	10 to 55 Hz, 1.0-mm double amplitude
Shock resistance	200 m/s ²
Dielectric strength	500 V AC (between insulated circuits)
Ambient temperature	Operating: 0 to 55°C Storage: -20 to 65°C
Ambient humidity	Operating: 35% to 85% (with no condensation) Storage: 25% to 85% (with no condensation)
Operating environment	No corrosive gases
Mounting method	M4 screws or 35-mm DIN track mounting
Mounting strength	50 N Track direction: 10 N • m
Terminal strength	Pulling: 50 N Tightening: 0.6 to 1.18 N • m
Node number settings	The node number is set on a DIP switch. (Set the node number before turning ON the Slave.)
Weight	SRT□-ID08S: 100 g max. SRT□-ND08S: 80 g max.

- Note**
- Maintain a voltage of 20.4 to 26.4 V DC when using a 2-wired Proximity Sensor.
 - This is the current consumption when all contacts are OFF, not including the current consumption of the sensors. Be sure to take the sensor's current into account when supplying power from a CompoBus/S cable. The maximum current consumption of the Sensor Terminal can be calculated from the following equation:

$$\text{Max. current consumption} = \text{current consumption of the Sensor Terminal} + \{(\text{input current} + \text{output current} + \text{sensor's current consumption}) \times \text{the number of sensors being used}\}$$

The total current consumption of the sensors must be less than 500 mA.

Input Specifications

Item	Specification
ON voltage	12 V DC min. (between each input terminal and V_{CC} , the external sensor power supply)
OFF voltage	4 V DC max. (between each input terminal and V_{CC} , the external sensor power supply)
OFF current	1 V max.
Input current	10 mA max./point
ON delay time	1 ms max.
OFF delay time	1.5 ms max.
Insulation resistance	20 M Ω min. at 250 V DC (between insulated circuits)
Insulation method	Photocoupler

Output Specifications

Item	Specification
Rated output current	20 mA max.
Residual voltage	1 V max. (between each output terminal and V_{CC} , the external sensor power supply)
Leakage current	0.1 mA max. (between each output terminal and V_{CC} , the external sensor power supply)
ON delay time	1.0 ms max.
OFF delay time	1.5 ms max.
Insulation resistance	20 M Ω min. at 250 V DC
Insulation method	Photocoupler

Slave Components

The following diagram shows the main components of the Sensor Terminals. The functions of these components are described below.

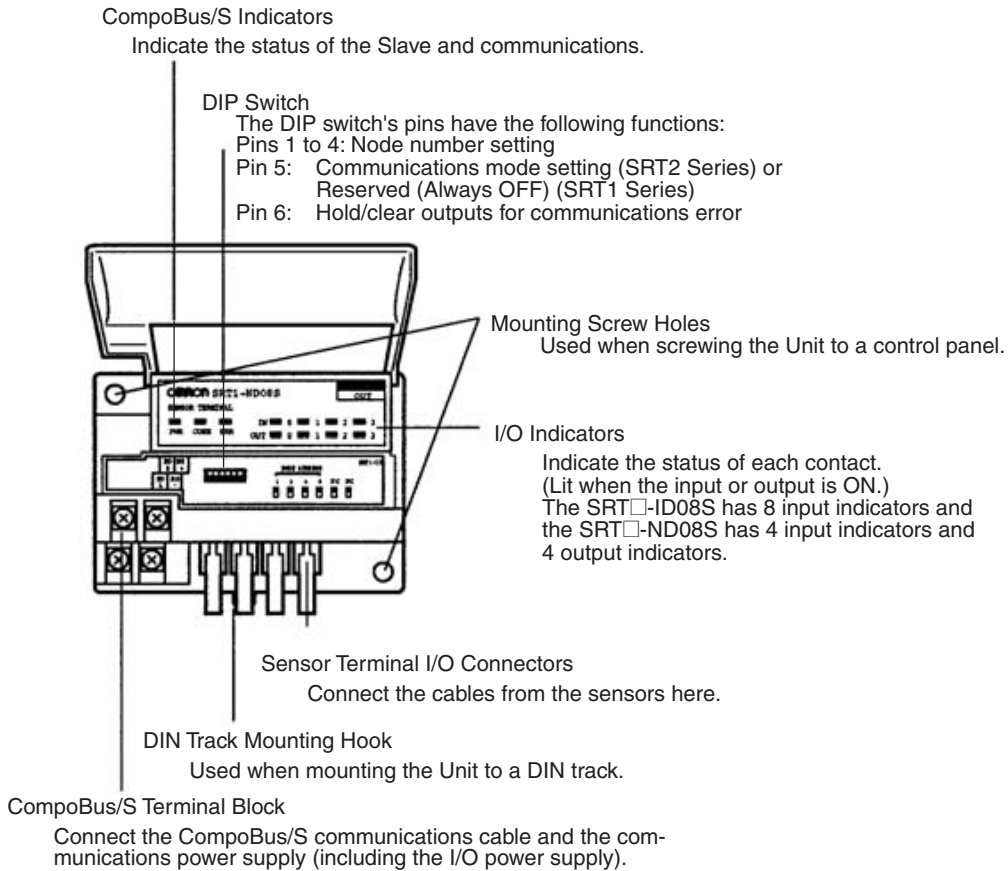

Indicators

The following table shows the meaning of the indicators.

Indicator	Status	Meaning
PWR (green)	ON	The communications power supply is ON.
	OFF	The communications power supply is OFF.
COMM (yellow)	ON	Normal communications
	OFF	A communications error has occurred or the Unit is in standby status.
ERR (red)	ON	A communications error has occurred.
	OFF	Normal communications or the Unit is in standby status.
INO to 3 (4 inputs/outputs) INO to 7 (8 inputs) (yellow)	ON	The corresponding input is ON.
	OFF	The corresponding input is OFF or the Unit is in standby status.
OUT0 to 3 (4 inputs/outputs) (yellow)	ON	The corresponding output is ON.
	OFF	The corresponding output is OFF or the Unit is in standby status.

DIP Switch

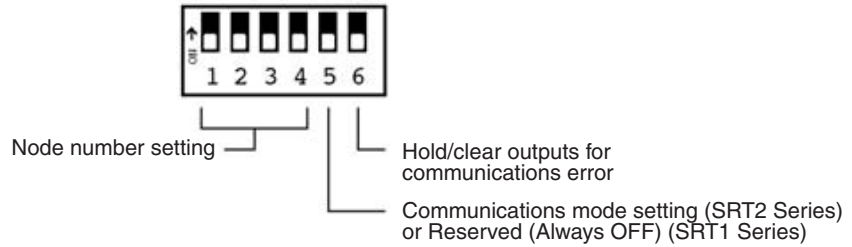

Note Always turn OFF the Slave before changing DIP switch settings.

Node Number Settings

Set the node number with pins 1 through 4, as shown in the following table.

Node number	Pin 4 (8)	Pin 3 (4)	Pin 2 (2)	Pin 1 (1)
0	OFF	OFF	OFF	OFF
1	OFF	OFF	OFF	ON
2	OFF	OFF	ON	OFF
3	OFF	OFF	ON	ON
4	OFF	ON	OFF	OFF
5	OFF	ON	OFF	ON
6	OFF	ON	ON	OFF
7	OFF	ON	ON	ON
8	ON	OFF	OFF	OFF
9	ON	OFF	OFF	ON
10	ON	OFF	ON	OFF
11	ON	OFF	ON	ON
12	ON	ON	OFF	OFF
13	ON	ON	OFF	ON
14	ON	ON	ON	OFF
15	ON	ON	ON	ON

Note The actual node number setting range depends on the type of PLC in which the Master is mounted as well as the Master’s settings. Refer to 2-1 Communications Specifications for details.

Communications Mode Settings (SRT2 Series Only)

The following communications modes are set with pin 5 as shown below.

Pin 5	Communications mode	Communications distance	Communications baud rate	Communications cycle time
OFF	High-speed Communications Mode	100 m max.	750 kbps	0.5 or 0.8 ms
ON	Long-distance Communications Mode	500 m max.	93.75 kbps	4.0 or 6.0 ms

The communications mode settings using pin 5 only apply to the SRT2-series Slaves and cannot be used with the SRT1-series Slaves, which operate in High-speed Communications Mode at all times.

Note Make sure that the communications mode of the Slave is the same as that of the Master Unit. If the communications modes are not the same, normal communications with the Master Unit will not be possible. The operating status of the Slave can be verified with LED indicators. Refer to 6-5-1 Indicators.

Hold/Clear Outputs for Communications Error

Pin 6 is used to set the output data status when a communications error occurs, as shown in the following table.

Pin 6	Output setting
OFF	Clear output status.
ON	Maintain output status.

Sensor Compatibility

Use the following flowchart to determine whether a sensor is compatible with the Sensor Terminal.

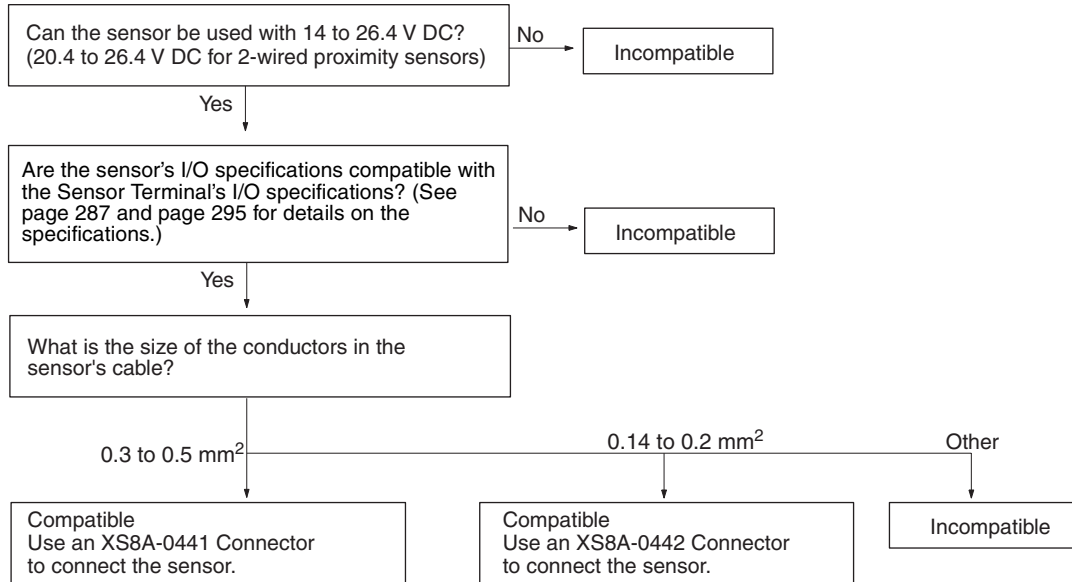

Note The XS8A-0441 and XS8A-0442 Connectors are not provided with the Unit. The Connectors must be ordered separately.

Internal Circuits

The following diagram shows the internal circuits for the SRT□-ID08S (8 inputs).

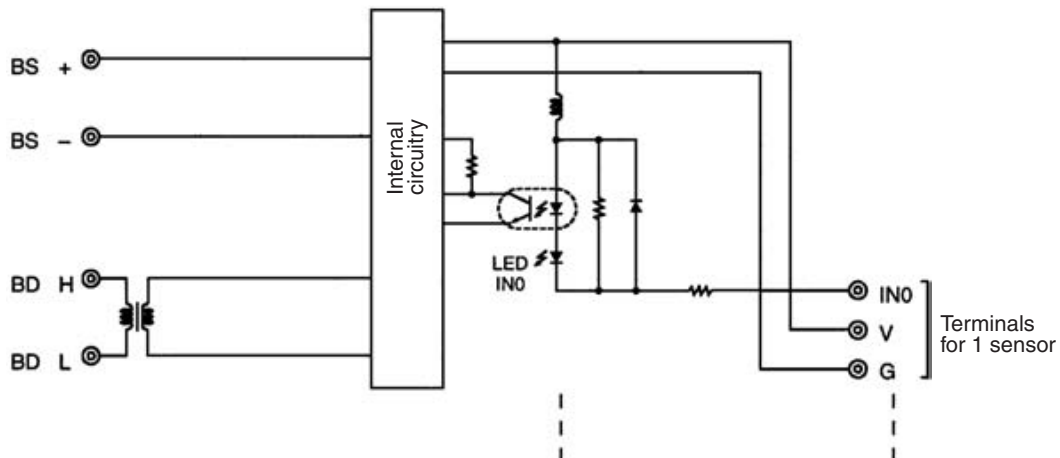

The following diagram shows the internal circuits for the SRT□-ND08S (4 inputs and 4 outputs).

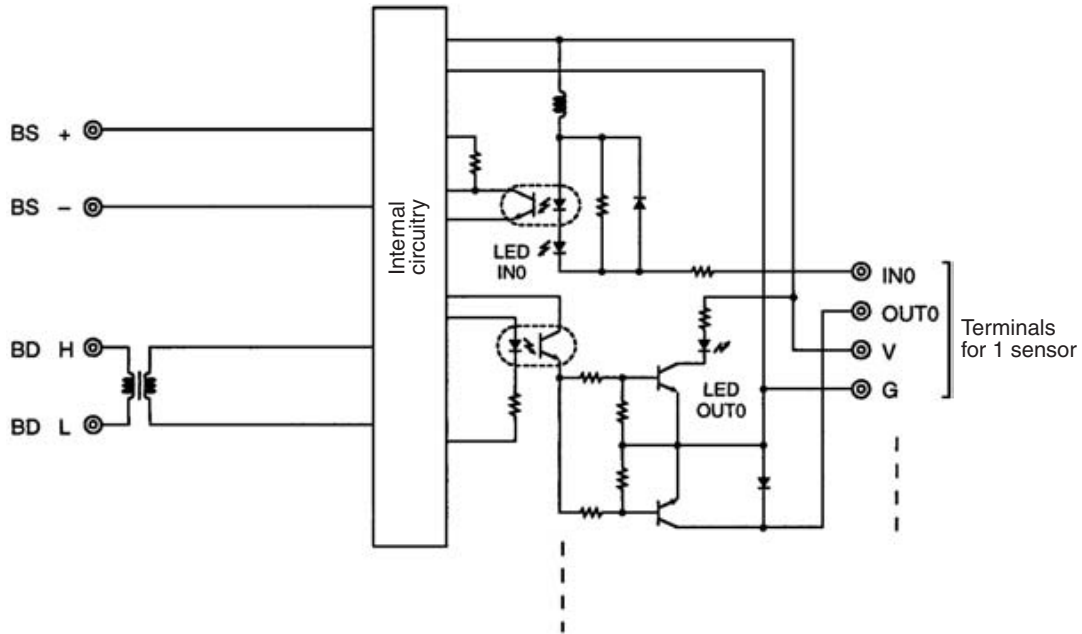

Terminal Arrangement and Wiring

The following diagram shows the terminal arrangement and wiring for the SRT□-ID08S (8 inputs).

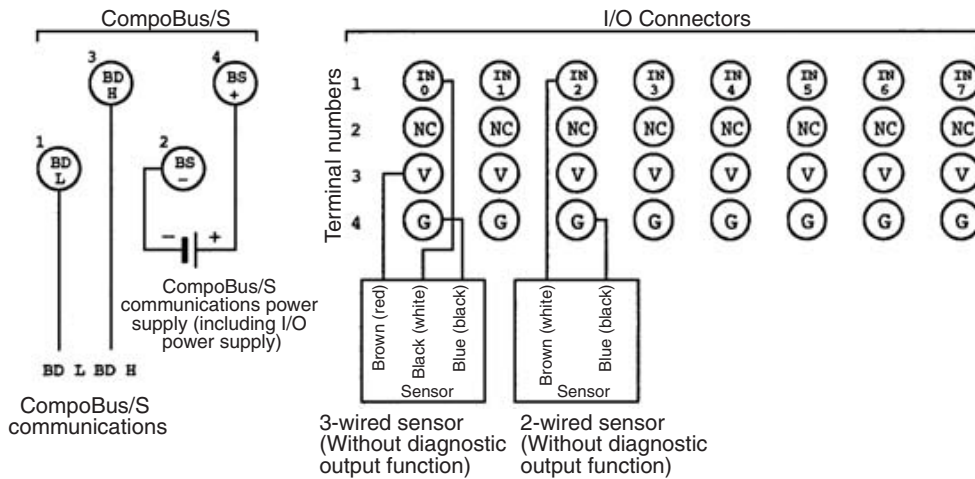

Note In accordance with the changes in the standards for photoelectric sensors and proximity sensors, wire colors have been changed. Colors in parentheses are the old wire colors.

The following table shows the terminal arrangement and wiring for the Sensor Terminal's I/O Connector.

Terminal number	Function
1	IN (Input)
2	NC (Not used.)
3	V _{CC} (V) (External sensor power supply, + terminal)
4	GND (G) (External sensor power supply, – terminal)

The following diagram shows the terminal arrangement and wiring for the SRT□-ND08S (4 inputs and 4 outputs).

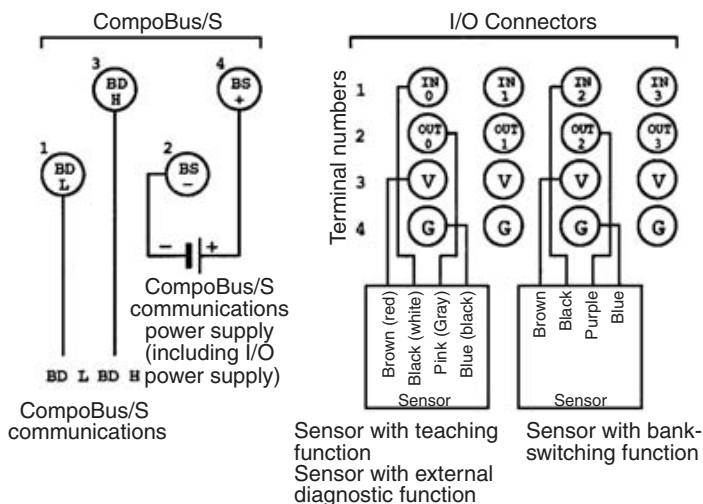

Note In accordance with the changes in the standards for photoelectric sensors and proximity sensors, wire colors have been changed. Colors in parentheses are the old wire colors.

The following table shows the terminal arrangement and wiring for the Sensor Terminal's I/O Connector.

Terminal number	Function
1	IN (Input)
2	OUT (Output)
3	V _{CC} (V) (External sensor power supply, + terminal)
4	GND (G) (External sensor power supply, – terminal)

SRT□-ID08S Dimensions

The following diagram shows the dimensions for the SRT□-ID08S (8 inputs). All dimensions are in mm.

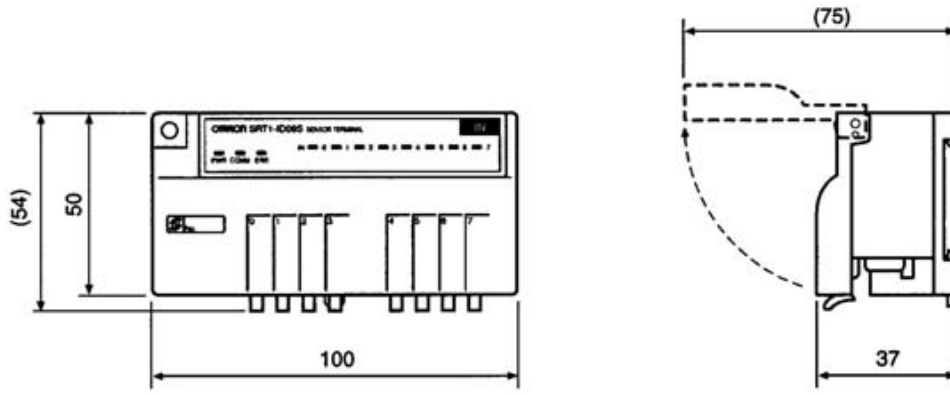

Mounting Holes

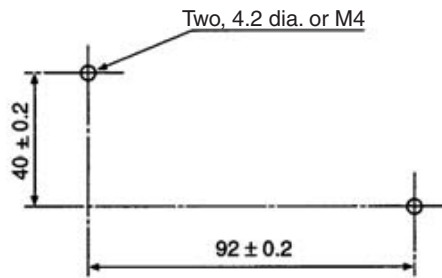

SRT□-ND08S Dimensions

The following diagram shows the dimensions for the SRT□-ND08S (4 inputs and 4 outputs). All dimensions are in mm.

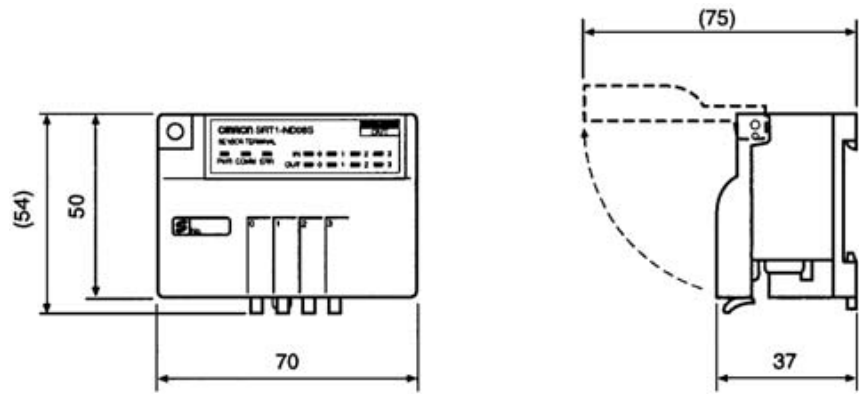

Mounting Holes

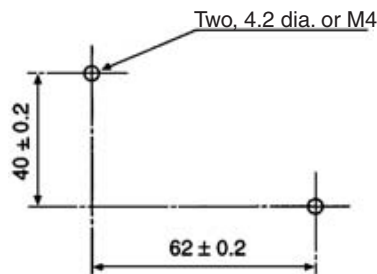

5-5-2 SRT□-OD08S Sensor Terminal with 8 Transistor Outputs

Specifications

The following tables show the ratings and output specifications for the SRT□-OD08S.

Ratings

Item	Specification
Models	SRT1-OD08S SRT2-OD08S
Output points	8 points
Communications mode	SRT1-OD08S: High-speed Communications Mode SRT2-OD08S: High-speed Communications Mode or Long-distance Communications Mode
Power supply type	Local power supply
Communications power supply voltage (including I/O power supply)	20.4 to 26.4 V DC (24 V DC $+10\%$ / -15%) (Power can be supplied from the communications cable)
I/O power supply current	2.4 A max.
Current consumption (See note.)	50 mA max. at 24 V DC
Noise immunity	± 1.5 kVp-p a pulse width of 0.1 to 1 μ s and a rise time of 1 ns (via impulse noise simulator)
Vibration resistance	10 to 55 Hz, 1.5 mm double amplitude
Shock resistance	Malfunction: 200 m/s ² (approx. 20G) Destruction: 300 m/s ² (approx. 30G)
Dielectric strength	500 V AC (between insulated circuits)
Ambient temperature	Operating: 0 to 55°C Storage: -20 to 65°C (with no icing or condensation)
Ambient humidity	Operating: 35% to 85% (with no condensation) Storage: 25% to 85% (with no condensation)
Operating environment	No corrosive gases
Mounting method	M4 screws or 35-mm DIN track mounting
Mounting strength	50 N Track direction: 10 N • m
Terminal strength	Pulling: 50 N Tightening torque: 0.6 to 1.18 N • m Excluding strength of connector lock
Node number settings	The node number is set on a DIP switch. (Set the node number before turning ON the Slave.)
Weight	100 g max.

Note The current consumption is the value when all points are OFF, excluding the current consumption of the external sensor connected to the Sensor Terminal inputs and the current consumption of the load connected to the Sensor Terminal outputs.

Output Specifications

Item	Specification
Output current	0.3 A max./point
Residual voltage	0.6 V max.
Leakage current	0.1 mA max.
ON delay time	0.5 ms max.
OFF delay time	1.5 ms max.

Item	Specification
Insulation method	Photocoupler
Output indicators	LED (yellow)

Slave Components

The following diagram shows the main components of the SRT□-OD08S Sensor Terminals. The functions of these components are described below.

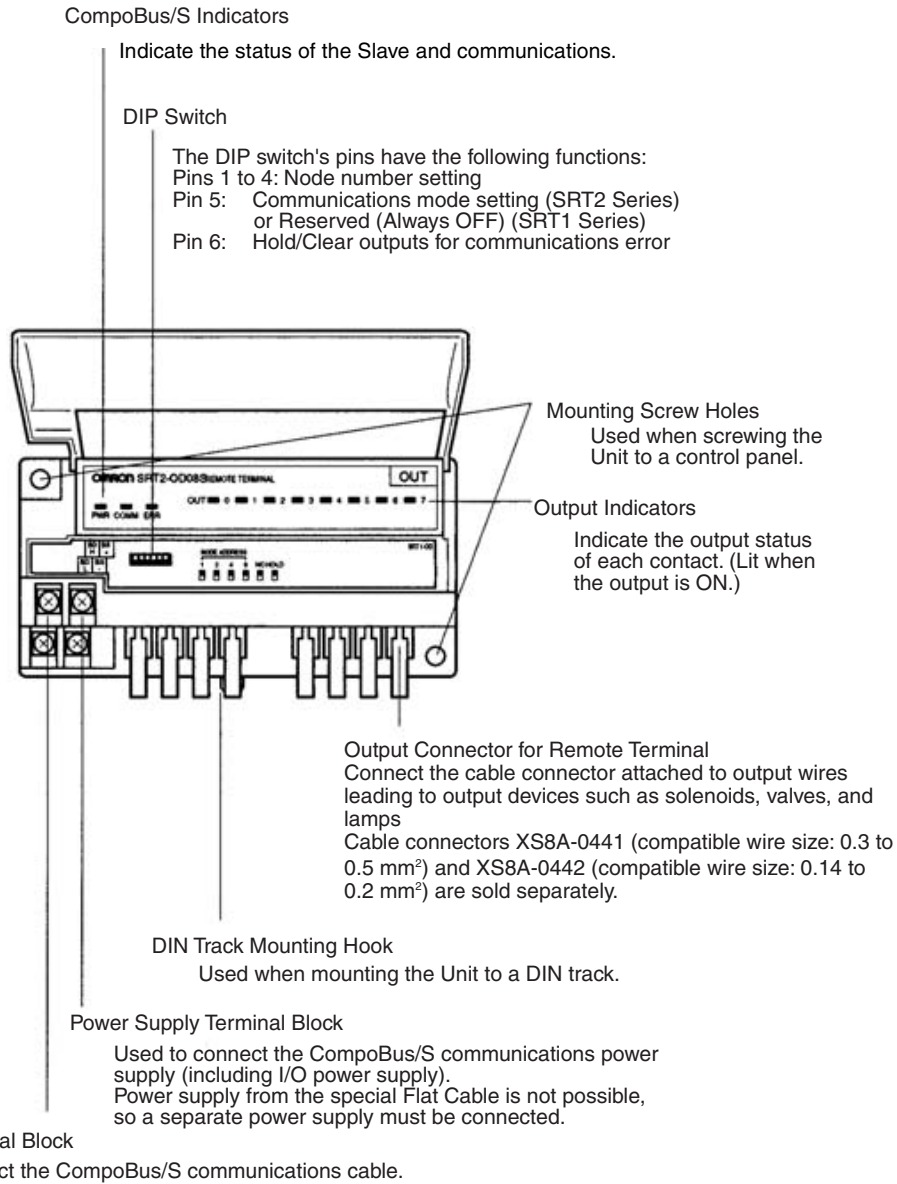

Indicators

The following table shows the meaning of the indicators.

Indicator	Status	Meaning
PWR (green)	ON	The external power supply is ON.
	OFF	The external power supply is OFF.
COMM (yellow)	ON	Normal communications
	OFF	A communications error has occurred or the Unit is in standby status.
ERR (red)	ON	A communications error has occurred.
	OFF	Normal communications or the Unit is in standby status.

Indicator	Status	Meaning
OUT 0 to 7 (yellow)	ON	The corresponding output is ON.
	OFF	The corresponding output is OFF or the Unit is in standby status.

DIP Switch

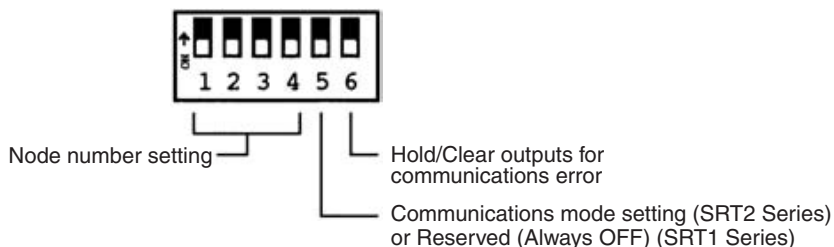

- Note**
1. Always turn OFF the Slave before changing DIP switch settings.
 2. In the SRT1 Series, pin 5 must always be left OFF. Otherwise, the Unit may not function correctly.

Hold/Clear Outputs for Communications Error

Pin 6 is used to set the output data status when a communications error occurs, as shown in the following table.

Pin 6 (HOLD)	Output setting
OFF	Clear output status.
ON	Maintain output status.

Communications Mode Settings (SRT2 Series Only)

The following communications modes are set with pin 5.

Pin 5	Communications mode	Communications distance	Communications baud rate	Communications cycle time
OFF	High-speed Communications Mode	100 m max.	750 kbps	0.5 or 0.8 ms
ON	Long-distance Communications Mode	500 m max.	93.75 kbps	4.0 or 6.0 ms

The communications mode settings using pin 5 only apply to the SRT2-series Slaves and cannot be used with the SRT1-series Slaves, which operate in High-speed Communications Mode at all times.

- Note** Make sure that the communications mode of the Slave is the same as that of the Master Unit. If the communications modes are not the same, normal communications with the Master Unit will not be possible. The operating status of the Slave can be verified with LED indicators. Refer to 6-5-1 *Indicators* for details.

Node Number Settings

Set the node number with pins 1 through 4, as shown in the following table.

Node number	Pin 4 (8)	Pin 3 (4)	Pin 2 (2)	Pin 1 (1)
0	OFF	OFF	OFF	OFF
1	OFF	OFF	OFF	ON
2	OFF	OFF	ON	OFF
3	OFF	OFF	ON	ON
4	OFF	ON	OFF	OFF
5	OFF	ON	OFF	ON
6	OFF	ON	ON	OFF
7	OFF	ON	ON	ON
8	ON	OFF	OFF	OFF
9	ON	OFF	OFF	ON
10	ON	OFF	ON	OFF
11	ON	OFF	ON	ON
12	ON	ON	OFF	OFF
13	ON	ON	OFF	ON
14	ON	ON	ON	OFF
15	ON	ON	ON	ON

Note The actual node number setting range depends on the type of PLC in which the Master is mounted as well as the Master's settings. Refer to *2-1 Communications Specifications* for details.

Compatible External Devices and Cables

Remote Terminals with Connector Output Transistors use the XS8A-0441 and XS8A-0442 Connectors (sold separately) to connect to external devices. Use the following flowchart to check the compatibility of external devices and cables. Refer to *3-4-3 Cable Connector Wiring and Assembly* for details on the assembly, wiring, and installation of cable connectors.

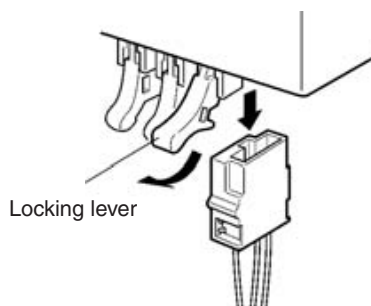

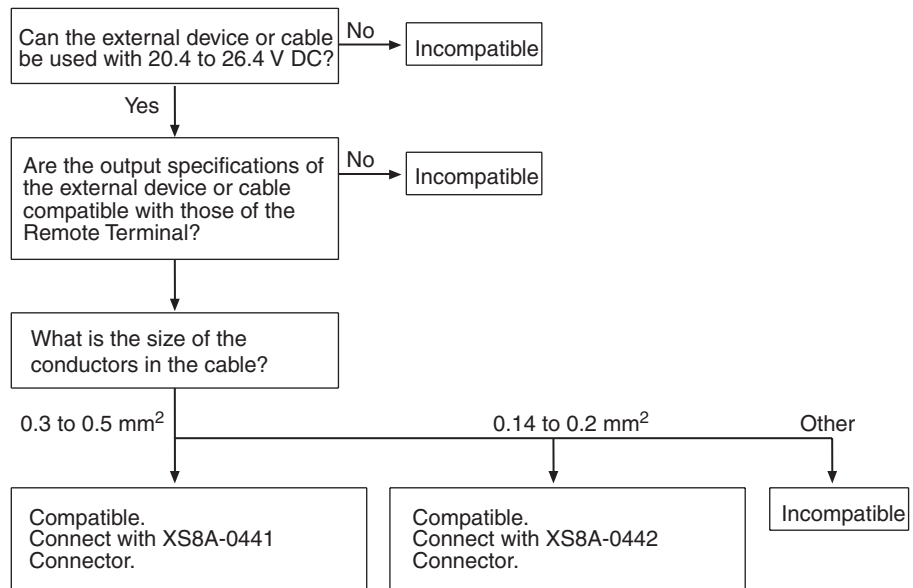

Note The XS8A-0441 and XS8A-0442 Connectors are not provided with the Unit. The Connectors must be ordered separately.

Internal Circuits

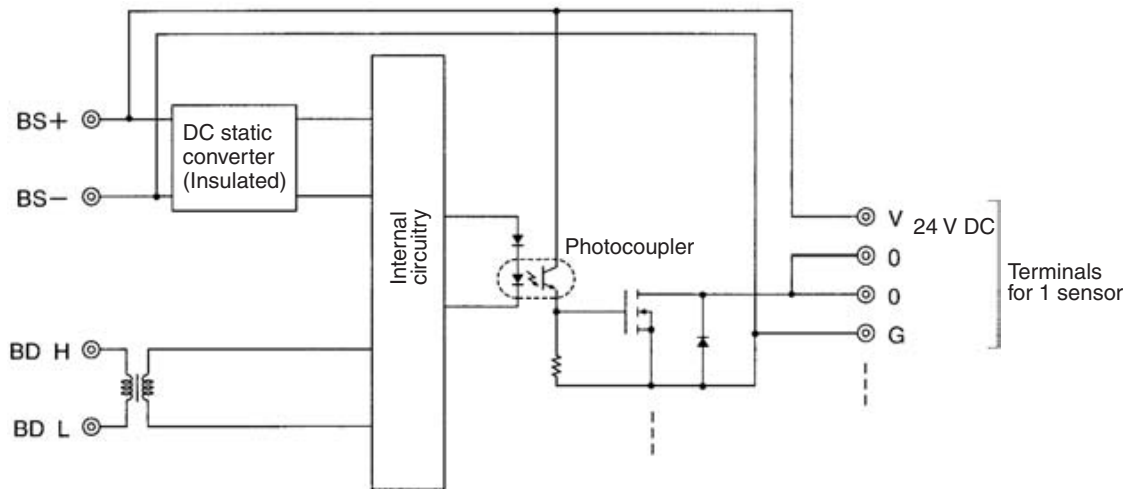

Terminal Arrangement and Wiring

internal circuitry. The following diagram shows the terminal arrangement and wiring for the SRT□-OD08S.

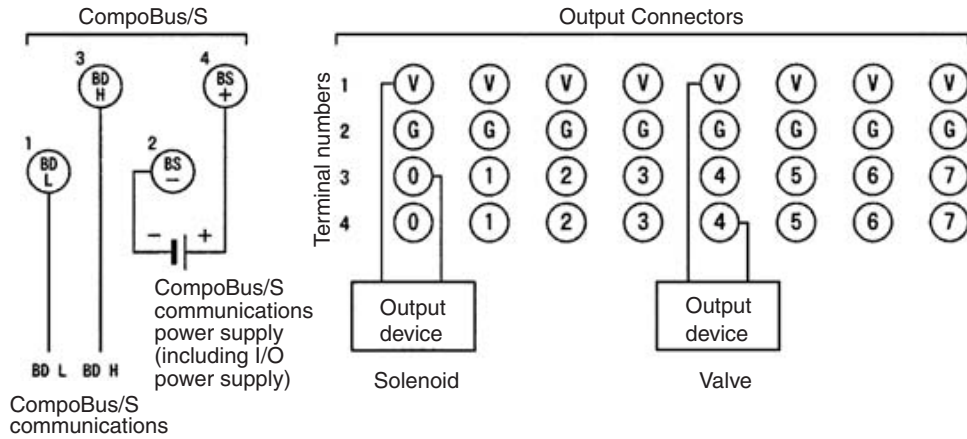

The following table shows the terminal arrangement and wiring for the Remote Terminal's output connector.

Terminal number	Function
1	V _{CC} (V) (External device power supply, + terminal)
2	GND (G) (External device power supply, - terminal)
3	OUT (Output)
4	

- Note**
1. Terminals 3 and 4 are connected internally, so external devices should be connected to terminal 1 (+24 V) and either terminal 3 or 4.
 2. The BS- and BS+ terminals of the communications power supply (including the I/O power supply) cannot be supplied from a flat cable, so they must be supplied separately.
 3. When inductive loads such as solenoids and valves are used, either use loads with built-in diodes that absorb the back-electromotive force or connect a diode externally.

SRT□-OD08S Dimensions The following diagram shows the dimensions for the SRT□-OD08S. All dimensions are in mm.

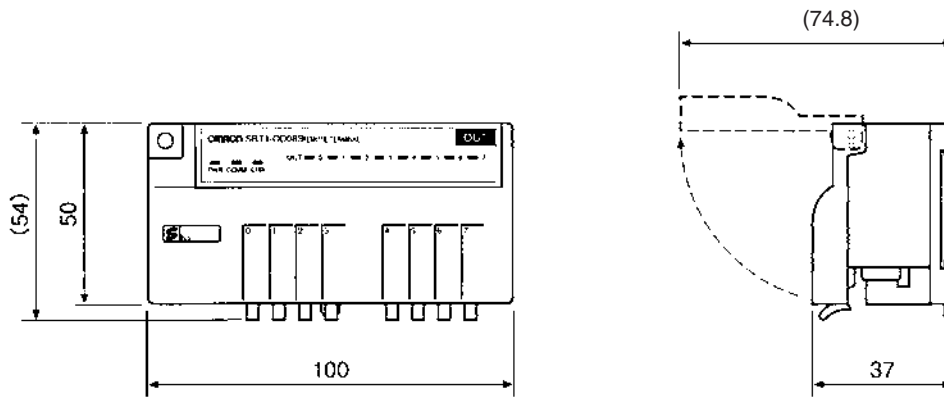

Mounting Holes

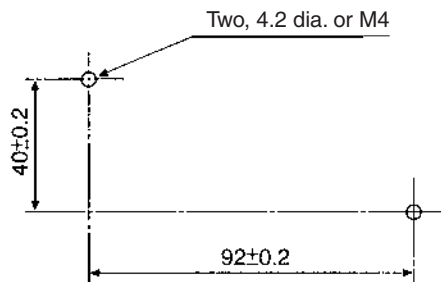

5-6 Fiber Amplifier Communications Units

5-6-1 E3X-SRT21 Fiber Amplifier Communications Unit

The Fiber Amplifier Communications Units are Communications Units for E39-TM1 Terminal Block Units or E3X-DA-N-series Digital Fiber Amplifier Units used with Optical Fiber Sensors.

Note In the following description, Digital Fiber Amplifier Units and Terminal Block Units are referred to collectively as Fiber Amplifier Units

The E3X-SRT21 uses CompoBus/S and receives input from the Fiber Amplifier Unit. (Models that function as DeviceNet or RS-422A Slaves are also available.)

Fiber Amplifier Units with connectors can also be used. Data is exchanged with the Fiber Amplifier Units by connecting the Fiber Amplifier Communications Unit to the left side of the multiple Fiber Amplifier Units.

The E3X-MC11 Mobile Console for Fiber Amplifier Units can also be connected.

This section provides an overview of the specifications and functions of the Fiber Amplifier Communications Unit for CompoBus/S. For details, refer to the *Fiber Amplifier Communications Unit Operation Manual* (Cat. No. Z152)

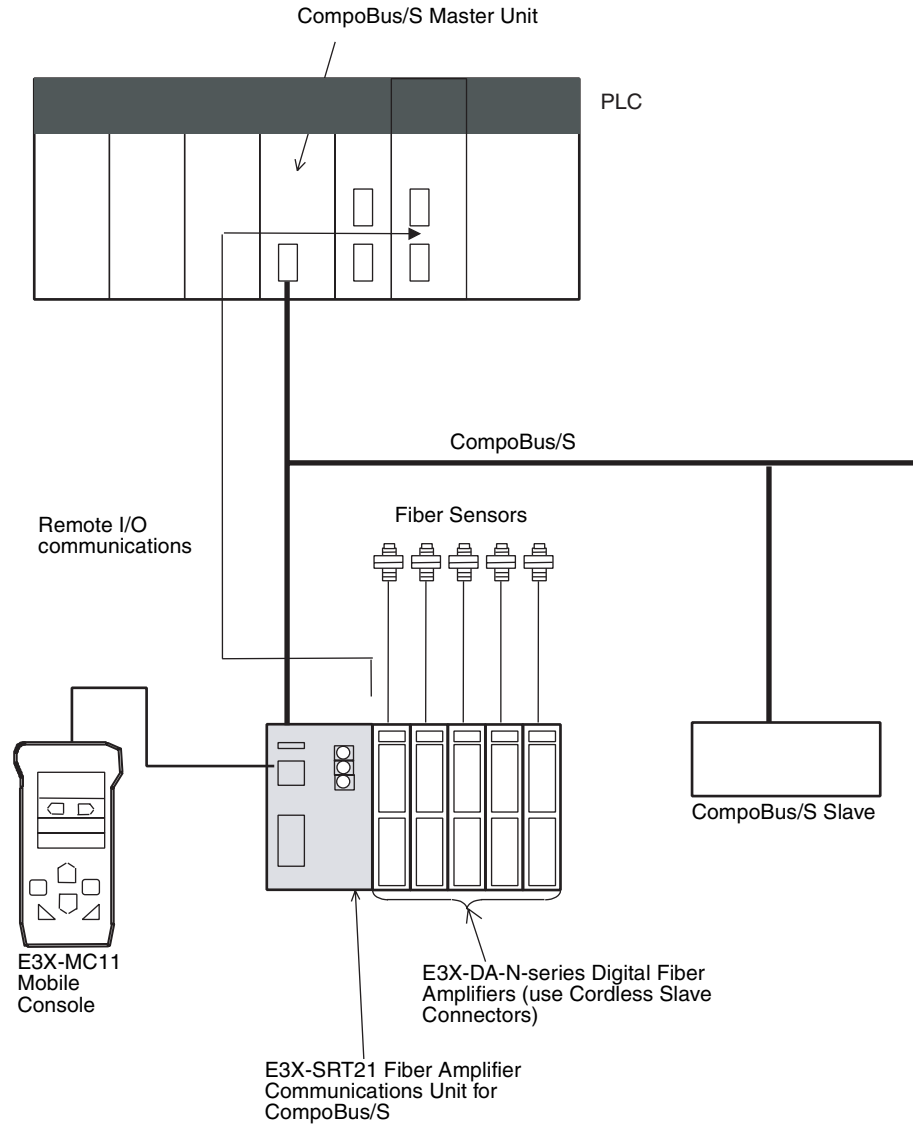

The unit numbers (addresses) are allocated to the Digital Fiber Amplifiers in order starting from the left, as follows:
 Amplifiers that use one node: Unit numbers 1 to 6
 Amplifiers that use two nodes: Unit numbers 1 to 14

Specifications

Item	Specification
Models	E3X-SRT21
I/O points and I/O connection conditions	6 inputs + 2 status points input from Fiber Amplifier Unit or 14 inputs + 2 status points input from Fiber Amplifier Unit (switch using DIP switch setting)

Item	Specification
Connection	Inputs: Fiber Amplifier Units Communications: Communications Connector (standard connector provided with Unit) I/O power: Communications Connector (standard connector provided with Unit)
Power supply type	Network power supply
Communications power supply voltage	14 to 26.4 V DC (Power can be supplied from the communications cable)
I/O power supply voltage	
Current consumption (See note.)	Communications power: 30 mA max. at 24 V DC
Maximum input delay time	Up to 8 Sensors connected: $0.1 \times n + 1.5$ (ms) (n: unit number) 9 or more Sensors connected: $0.2 \times n + 1.5$ (ms) (n: unit number)
Ambient temperature	Operating: -20 to 55°C (with no icing or condensation) Storage: -30 to 70°C (with no icing or condensation)
Ambient humidity	Operating: 35% to 85% (with no condensation)
Operating environment	No corrosive gases
Node number settings	The node number is set on a rotary switch. (Set the node number before turning ON the Slave.)
Dimensions	$30 \times 34.6 \times 71.3$ mm (W \times H \times D)
Weight	150 g max.

Note This is the current consumption when all the maximum simultaneous input points are ON, excluding the current consumption of external sensors.

Slave Part Names and Functions

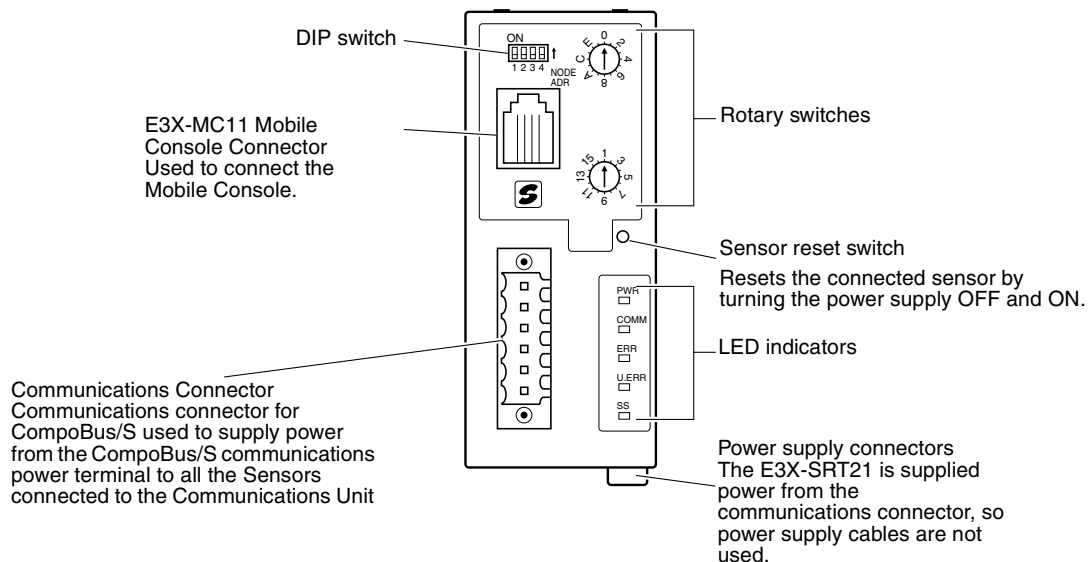

Indicators

The following table shows the meaning of the indicators.

Indicator	Name	Status	Meaning
PWR (green)	Power	ON	The communications power supply is ON.
		OFF	The communications power supply is OFF.
COMM (yellow)	Communica-tions	ON	Normal CompoBus/S communica-tions.
		OFF	A CompoBus/S communications error has occurred or the Unit is in standby status.
ERR (red)	Communica-tions error	ON	A CompoBus/S communications error has occurred.
		OFF	Normal CompoBus/S communica-tions or the Unit is in standby status.
U.ERR (red)	Unit error	ON	A Unit error has occurred.
		OFF	The Unit is communicating normally or is in standby status.
SS (green)	Sensor com-munications status	ON	Normal Sensor communications
SS (red)		ON	A Sensor communications error has occurred.
SS (---)		OFF	Sensors are in communications wait status or power is turned OFF.

Switch Settings

Rotary Switches



CompoBus/S node number setting



Number of connected Sensors registered.

Registers the number of connected Sensors. Registering the number of Sensors allows detection of errors in the configuration. Up to 14 Fiber Amplifier Units can be connected, so an error will occur if this switch is set to 15 or 16.

Note Fiber Amplifier Units that use two unit numbers (E3X-DA6TW, E3X-DA8TW) must be counted as two Units when counting the number of Sensors.

DIP Switch

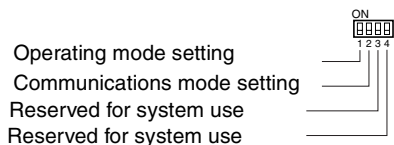

Operating Mode Setting (Pin 1)

This pin sets the operating mode. The maximum number of Fiber Amplifier Units that can be connected and the nodes that each Unit is allocated depends on the operating mode, as follows:

Pin 1 (MODE)	Maximum number of Fiber Amplifier Units connected	Number of allocated nodes
OFF	6 Units	1 input node
ON	14 Units	2 input nodes

Note Fiber Amplifier Units that use two unit numbers (E3X-DA6TW, E3X-DA8TW) must be counted as two Units when counting the number of Sensors.

Communications Mode Setting (Pin 2)

This pin is used to switch the CompoBus/S communications mode

Pin 2 (DR)	Communications mode setting
OFF	High-speed Communications Mode
ON	Long-distance Communications Mode

Note The Slave communications mode setting must match the communications mode setting of the Master Unit. If the communications modes are different, the Master Unit will not communicate properly. Check the operating status of the Slaves using the indicators.

I/O Allocations

Pin 1 OFF (Up to 6 Sensors)

Up to 6 Sensors can be connected in this mode. The data is 8 bits and is stored in the IN Area, which is set as the node number area

Bit	Contents
00	Unit 1 ON/OFF data
01	Unit 2 ON/OFF data
02	Unit 3 ON/OFF data
03	Unit 4 ON/OFF data
04	Unit 5 ON/OFF data
05	Unit 6 ON/OFF data
06	Sensor Communications Error Flag
07	Sensor Communications Flag

Sensor Communications Error Flag

Bit 06 turns ON when the registered number of Sensors does not match the number of Sensors that are enabled to communicate, or when a communications error occurs after communications have been established with the Sensors.

Sensor Communications Flag

Bit 07 turns ON when communications are established with the Sensors.

Pin 1 ON (Up to 14 Sensors)

Up to 14 Sensors can be connected in this mode. The data allocated is 16 bits and is stored in the IN Area, as shown in the following table.

Node number	Node numbers actually used
Odd number	Node number setting – 1 to node number setting
Even number	Node number setting to node number setting + 1

Odd node number	Even node number	Bit	Contents
Node number -1	Node number	00	Unit 1 ON/OFF data
		01	Unit 2 ON/OFF data
		02	Unit 3 ON/OFF data
		03	Unit 4 ON/OFF data
		04	Unit 5 ON/OFF data
		05	Unit 6 ON/OFF data
		06	Unit 7 ON/OFF data
		07	Unit 8 ON/OFF data
Node number	Node number +1	00	Unit 9 ON/OFF data
		01	Unit 10 ON/OFF data
		02	Unit 11 ON/OFF data
		03	Unit 12 ON/OFF data
		04	Unit 13 ON/OFF data
		05	Unit 14 ON/OFF data
		06	Sensor Communications Error Flag
		07	Sensor Communications Flag

CompoBus/S Wiring

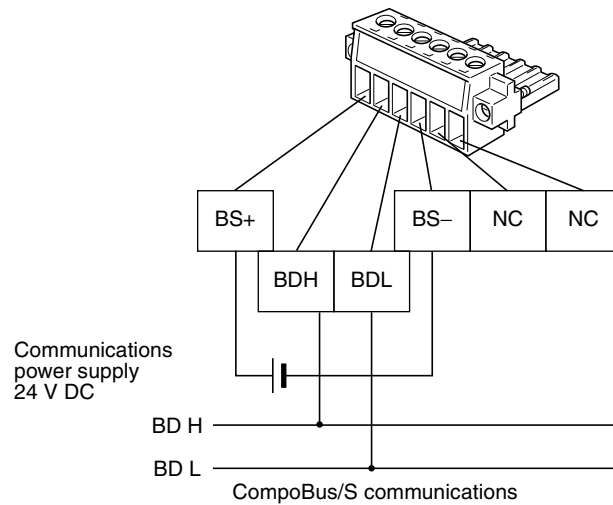

- Note**
1. The power supplied from the CompoBus/S communications power supply is supplied to the Communications Unit and all the Sensors connected to it. Consider the current consumption of the Communications Unit and the Sensors when selecting the power supply. The E3X-SRT21 is a network power supply. Special Flat Cable or 4-conductor VCTF cable can be used to supply power. Check that the allowable current of the communications cable is not exceeded.
 2. OMRON recommends the following products manufactured by Weidmuller Co., Ltd. for use as crimp terminals.

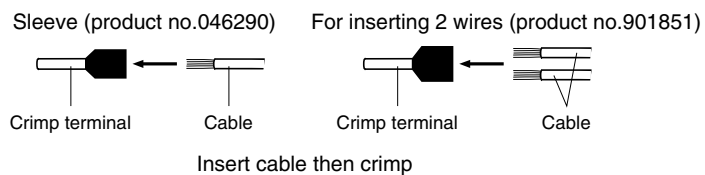

3. The following special tool is available:
Crimper PZ1.5 (product no. 900599) manufactured by Weidmuller Co. Ltd.

- 4. The tightening torque for the cable lock screws is 0.2 to 0.4 N-m.

Dimensions

The following diagram shows the dimensions of the Unit. All dimensions are in mm. The area shown with broken lines indicates the dimensions when the connector is mounted to the Unit.

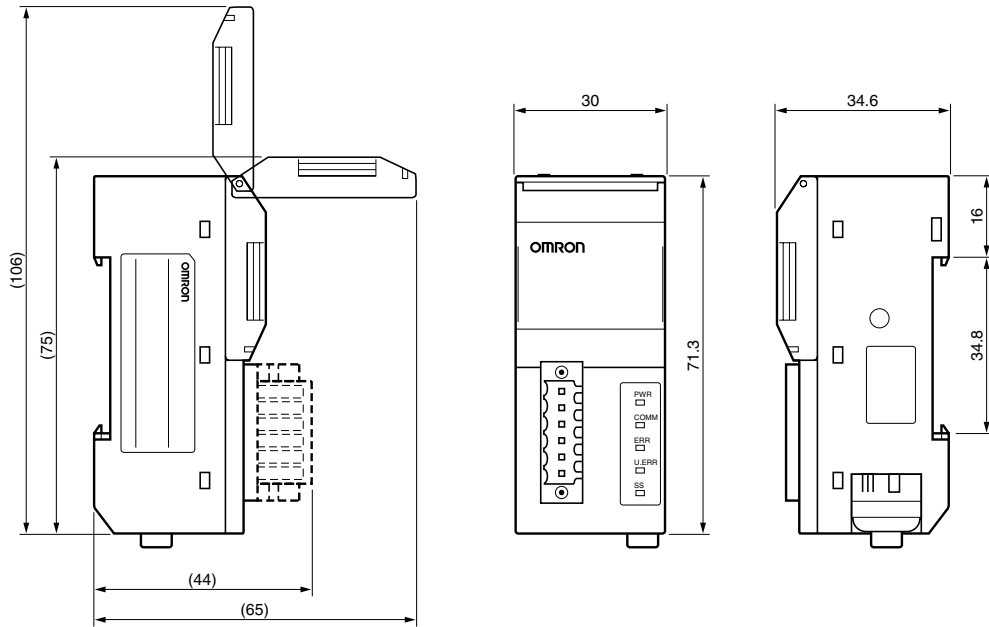

5-7 Analog Input Terminals

5-7-1 SRT2-AD04 Analog Input Terminal

Note Do not connect the Analog Input Terminal to any of the following incompatible Master Units or incorrect data may be transmitted.

PLC	Incompatible Master Units	Compatible Master Units
CS-series, C200HX/ C200HG/ C200HE-(Z)E, and C200HS	C200HW-SRM21	C200HW-SRM21-V1
CS-series	---	CS1W-SRM21
CJ-series	---	CJ1W-SRM21
CQM1	CQM1-SRM21	CQM1-SRM21-V1
SRM1 (Integrated with CPU Unit)	SRM1-C0□ SRM1-C0□-V1	SRM1-C0□-V2
CPM2C-S (Integrated with CPU Unit)	---	All Units

The Analog Input Terminal is also incompatible with the following Master Units:

3G8B3-SRM0□ CompoBus/S VME Board
C200PC-ISA□2-SRM SYSMAC Board

Specifications

The following tables show the ratings and input specifications for the SRT2-AD04.

General Specifications

Item	Specification
Model	SRT2-AD04
Input points	4, 3, 2, or 1 points (switchable using DIP switch) (4, 3, 2, or 1 words are allocated to the Master.)
Power supply type	Network power supply
Communications power supply voltage	14 to 26.4 V DC (Power can be supplied from the communications cable.)
Current consumption	Communications power: 100 mA max.
Noise immunity	±1.5 kVp-p with a pulse width of 0.1 to 1 μs and a rise time of 1 ns (via impulse noise simulator)
Vibration resistance	10 to 55 Hz, 1.0-mm double amplitude
Shock resistance	200 m/s ²
Dielectric strength	500 V AC for 1 minute (between insulated circuits)
Insulation resistance	20 MΩ min. at 250 V DC (between insulated circuits)
Ambient temperature	Operating: -10 to 55°C Storage: -25 to 65°C
Ambient humidity	Operating: 25% to 85% (with no condensation) Storage: 25% to 85% (with no condensation)
Operating environment	No corrosive gases
Mounting method	M4 screws or 35-mm DIN track mounting
Mounting strength	50 N Track direction: 10 N
Terminal strength	Pulling: 50 N
Weight	Approx. 120 g

Input Specifications

Item	Specification		
	Voltage input	Current input	
Input signal range	0 to 5 V 1 to 5 V 0 to 10 V -10 to 10 V	0 to 20 mA 4 to 20 mA	
	Input signal range settings for Input 0 and Input 1 are shared. Input signal range settings for Input 2 and Input 3 are shared.		
Max. signal input	±15 V	±30 mA	
Input impedance	1 MΩ min.	Approx. 250 Ω	
Resolution	1/6000 (Full scale)		
General precision	25°C	±0.3%FS	±0.4%FS
	0 to 55°C	±0.6%FS	±0.8%FS
Conversion time	1 ms/point (4 ms/4 points, 3 ms/3 points, 2 ms/2 points, or 1 ms/1 point)		
AD conversion output data	Binary data -10 to 10 V: Full scale F448 to 0 to 0BB8 Hex Other: Full scale 0000 to 1770 Hex		
Averaging Function	Can be set (with DIP switch)		
Burnout detection function	Available		
Insulation method	Between analog input and communications line: Photo-coupler Between each analog input signal: Non-insulated		

Slave Components

The following diagram shows the main components of the SRT2-AD04 Analog Input Terminal. The functions of these components are described below.

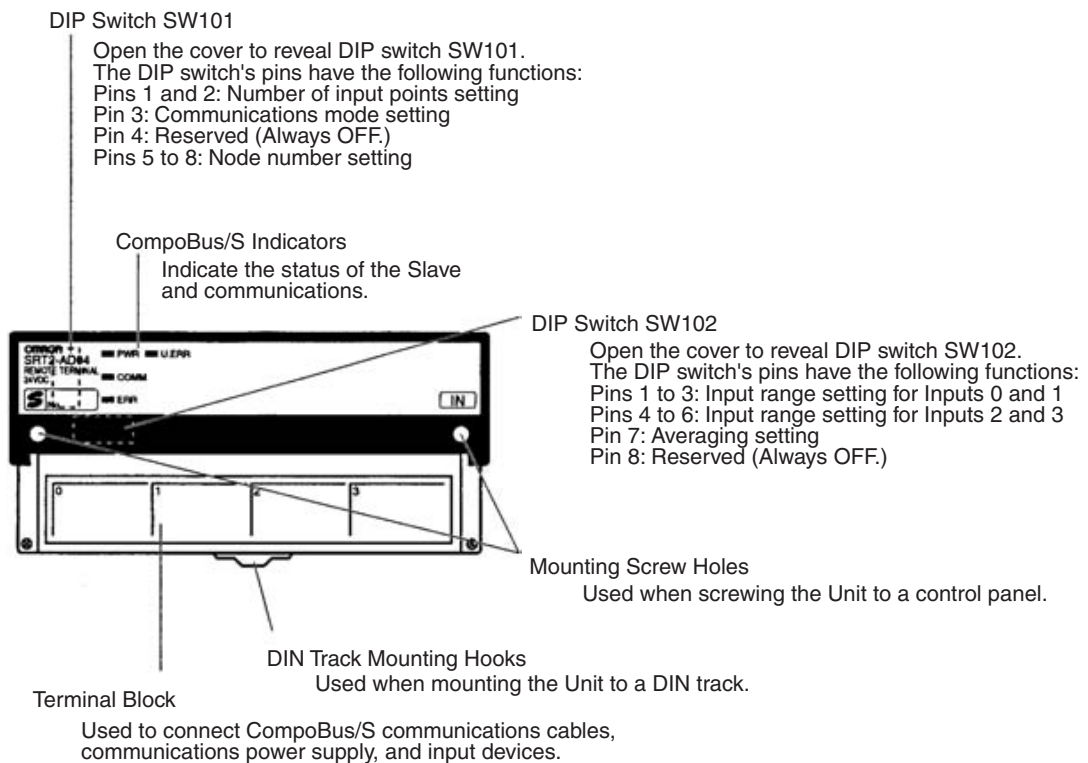

Indicators

The following table shows the meaning of the indicators.

Indicator	Status	Meaning
PWR (green)	ON	The communications power supply is ON.
	OFF	The communications power supply is OFF.
COMM (yellow)	ON	Normal communications
	OFF	A communications error has occurred or the Unit is in standby status.
ERR (red)	ON	A communications error has occurred.
	OFF	Normal communications or the Unit is in standby status.
U.ERR (red)	ON	An error has occurred in the Unit.
	OFF	Normal communications or the Unit is in standby status.

DIP Switches

Always turn OFF the Slave before changing DIP switch settings.

SW101

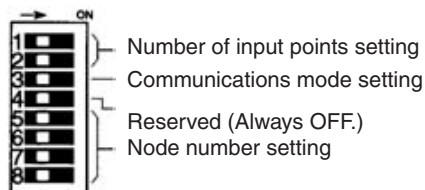

Pin 1	Pin 2	Number of input points setting
OFF	OFF	4 points (Factory setting)
OFF	ON	3 points (Inputs 0 to 2 valid)
ON	OFF	2 points (Inputs 0 and 2 valid)
ON	ON	1 point (Input 0 valid)

Pin 3	Communications mode setting
OFF	High-speed Communications Mode (Factory setting)
ON	Long-distance Communications Mode

Pin 4	Always set to OFF.

Note Make sure that the communications mode of the Slave is the same as that of the Master Unit. If the communications modes are not the same, normal communications with the Master Unit will not be possible. The operating status of the Slave can be verified with LED indicators. Refer to 6-5-1 *Indicators* for details.

Node Number Setting

Set the node number with pins 5 through 8, as shown in the following table.

Node number	Pin 5 (8)	Pin 6 (4)	Pin 7 (2)	Pin 8 (1)
0	OFF	OFF	OFF	OFF
1	OFF	OFF	OFF	ON
2	OFF	OFF	ON	OFF
3	OFF	OFF	ON	ON
4	OFF	ON	OFF	OFF
5	OFF	ON	OFF	ON
6	OFF	ON	ON	OFF
7	OFF	ON	ON	ON
8	ON	OFF	OFF	OFF
9	ON	OFF	OFF	ON
10	ON	OFF	ON	OFF
11	ON	OFF	ON	ON
12	ON	ON	OFF	OFF
13	ON	ON	OFF	ON
14	ON	ON	ON	OFF
15	ON	ON	ON	ON

A single Analog Input Terminal is allocated 64 points, 48 points, 32 points, or 16 points. Points are assigned as shown in the following table. Note that when a CQM1 Master Unit is used in 4-point mode, the Analog Input Terminal cannot be connected.

Allocated points	Node number setting	Node number actually used
64 points (4 inputs)	Odd	Node number setting – 1 to node number setting + 6
	Even	Node number setting to node number setting + 7
48 points (3 inputs)	Odd	Node number setting – 1 to node number setting + 4
	Even	Node number setting to node number setting + 5
32 points (2 inputs)	Odd	Node number setting – 1 to node number setting + 2
	Even	Node number setting to node number setting + 3
16 points (1 input)	Odd	Node number setting – 1 to node number setting
	Even	Node number setting to node number setting + 1

SW102

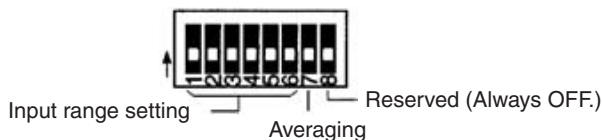

Pin 1	Pin 2	Pin 3	Range setting for Inputs 0 and 1
Pin 4	Pin 5	Pin 6	Range setting for Inputs 2 and 3
OFF	OFF	OFF	0 to 5 V (Factory setting)
ON	OFF	OFF	1 to 5 V
OFF	ON	OFF	0 to 10 V
ON	ON	OFF	-10 to 10 V
OFF	OFF	ON	4 to 20 mA
ON	OFF	ON	0 to 20 mA

Do not set to any values but those given above.

Pin 7	Averaging
OFF	No averaging (Factory setting)
ON	With averaging (8-time moving average)

Pin 8	Always set to OFF.
-------	--------------------

Note Input range settings for Input 0 and Input 1 are shared, and those for Input 2 and Input 3 are shared. An example is shown below.

Input 0 and Input 1: 4 to 20 mA (Pins 1, 2, 3 = OFF, OFF, ON)
 Input 2 and Input 3: 1 to 5 V (Pins 4, 5, 6 = ON, OFF, OFF)

Internal Circuits

The following diagram shows the internal circuits for the SRT2-AD04.

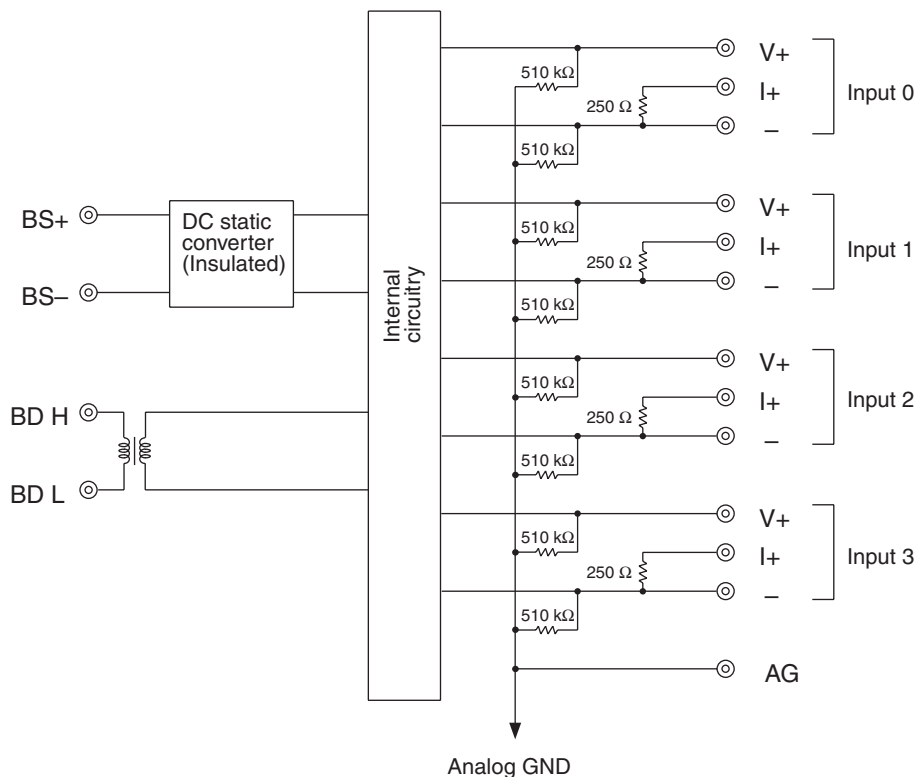

Terminal Block

Install the following M3 crimp terminals on the signal wires and connect them to the terminal block.



Note Tighten the terminal block screws to the specified tightening torque of 0.5 N·m.

The following diagram shows the terminal block for the SRT2-AD04.

BD H	BS +	AG	V0+	I0+	V1+	I1+	V2+	I2+	V3+	I3+
BD L	BS -	NC	AG	0-	NC	1-	NC	2-	NC	3-

Note For current input, short terminals V+ and I+.

Wiring

Wire the connector terminals of the Analog Input Terminal as shown below according to voltage input or current input.

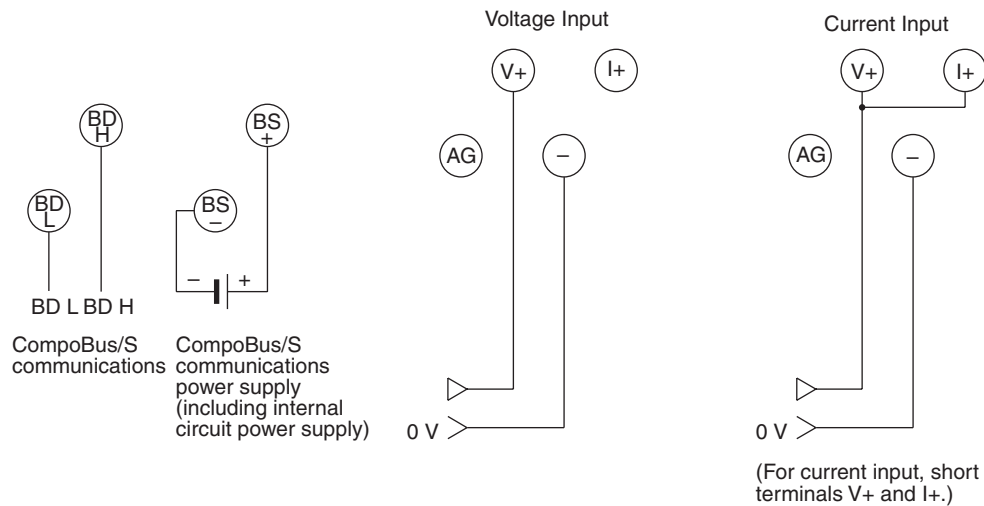

For current input, short terminals V+ and I+. Use the short circuiting fitting provided to accomplish this.

Input Range and Conversion Data

The analog data that is input will be converted to digital values according to the input range.

Note If the input range is surpassed, the AD conversion data will be fixed at the upper or lower limit.

-10 to 10 V

Voltages between -10 V and 10 V correspond to F448 to 0BB8 Hex (-3000 to 3000). The range of data that can be converted is F31C to 0CE4 Hex (-3300 to 3300). When voltage is negative, it is expressed as 2's complement (16

bits). In the event of disconnection, the data becomes the same value as in the case of 0 V input (0000 Hex).

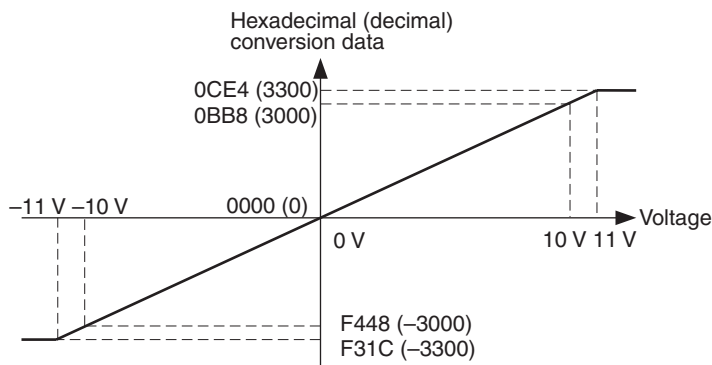

0 to 10 V

Voltages between 0 V and 10 V correspond to 0000 to 1770 Hex (0 to 6000). The range of data that can be converted is FED4 to 189C Hex (-300 to 6300). When voltage is negative, it is expressed by 2's complement (16 bits). In the event of disconnection, the data becomes the same value as in the case of 0 V input (0000 Hex).

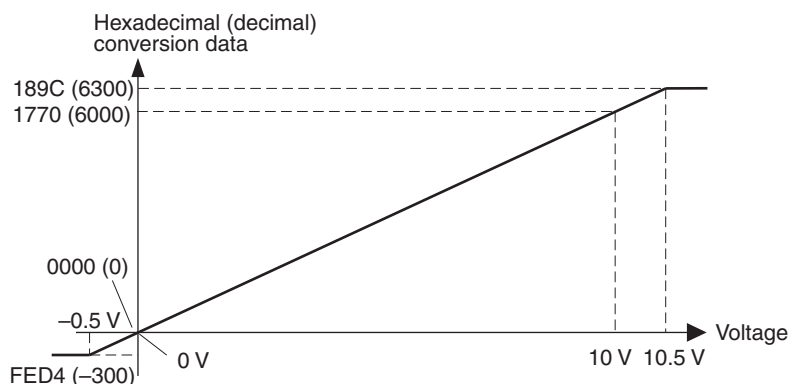

0 to 5 V

Voltages between 0 V and 5 V correspond to 0000 to 1770 Hex (0 to 6000). The range of data that can be converted is FED4 to 189C Hex (-300 to 6300). When voltage is negative, it is expressed by 2's complement (16 bits). In the event of disconnection, the data becomes the same value as in the case of 0 V input (0000 Hex).

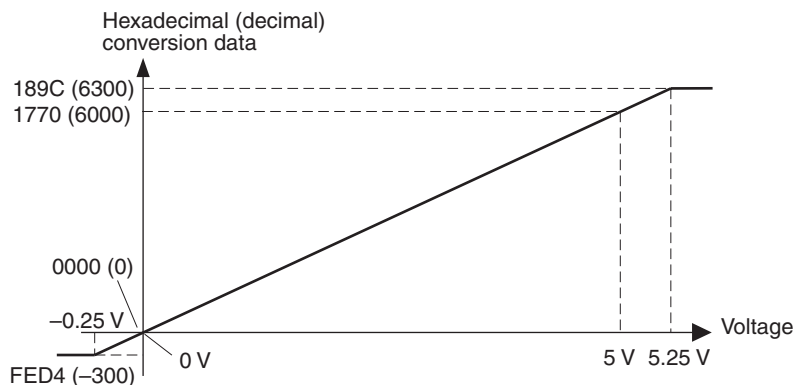

1 to 5 V

Voltages between 1 V and 5 V correspond to 0000 to 1770 Hex (0 to 6000). The range of data that can be converted is FED4 to 189C Hex (-300 to 6300).

When voltage is less than the input range (i.e., input voltage is less than 0.8 V), the burnout detection function is activated, and data becomes 7FFF.

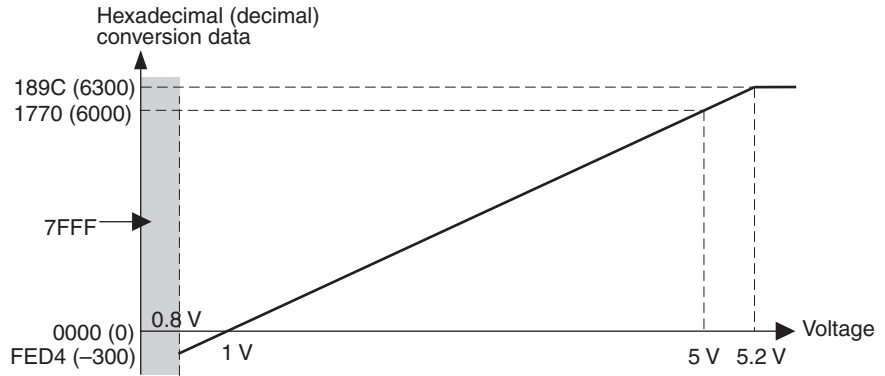

0 to 20 mA

Currents between 0 mA and 20 mA correspond to 0000 to 1770 Hex (0 to 6000). The range of data that can be converted is FED4 to 189C Hex (-300 to 6300). When current is negative, it is expressed by 2's complement (16 bits). In the event of disconnection, the data becomes the same value as in the case of 0 mA input (0000 Hex).

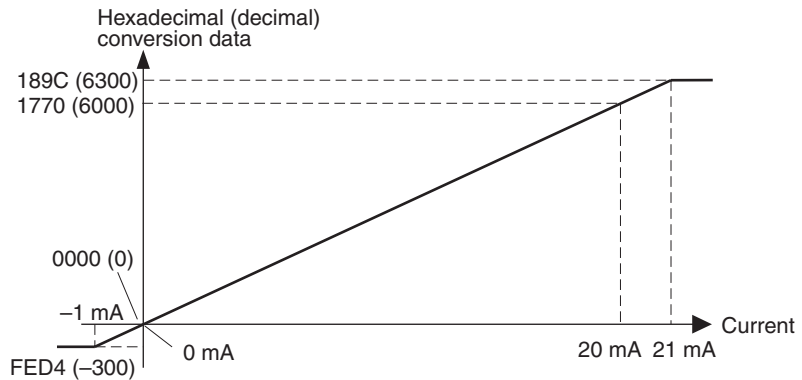

4 to 20 mA

Currents between 4 mA and 20 mA correspond to 0000 to 1770 Hex (0 to 6000). The range of data that can be converted is FED4 to 189C Hex (-300 to 6300). When current is less than the input range (i.e., input current is less than 3.2 mA) the burnout detection function is activated, and data becomes 7FFF.

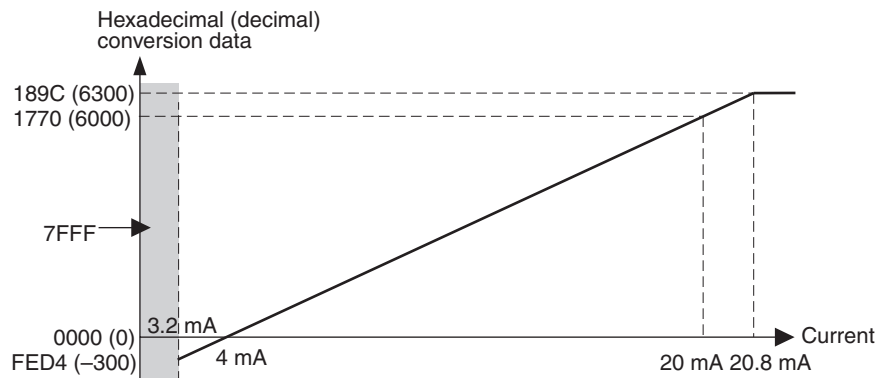

Switching between 4, 3, 2, and 1 Inputs

It is possible to restrict the number of inputs with pins 1 and 2 of DIP switch SW101. In this way, the sampling cycle can be set to 4 ms/4 points, 3 ms/3

points, 2 ms/2 points, or 1 ms/1 point, making conversions faster. In accordance with the number of inputs, the number of words allocated to the Analog Input Terminal in the PLC for the Master Unit will also be set to 4 words/4 points, 3 words/3 points, 2 words/2 points, or 1 word/1 point. When the number of inputs is 3, Inputs 0, 1, and 2 will be used; when the number of inputs is 2, Inputs 0 and 2 will be used; and when the number of inputs is 1, Input 0 will be used.

Averaging Function (8-time Moving Average)

When pin 7 of DIP switch SW102 is ON, the averaging function (8-time moving average) will be activated for all Inputs 0 to 3.

The averaging function outputs the average of the previous 8 inputs (moving average) as conversion data.

Turn ON this pin when the inputs fluctuate slightly but frequently as shown in the following figure. The averaging function will make the actual inputs smoother.

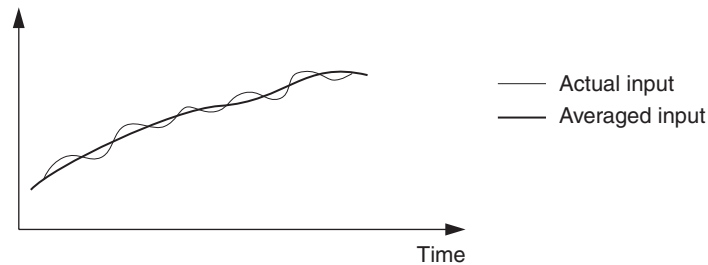

Note Even in this case, conversion data will be updated at the normal rate of 1 ms/point. After power is turned ON, the data transmitted first are sampled 8 times, averaged, and then output.

Burnout Detection Function

When the input range is 1 to 5 V or 4 to 20 mA, and the input signal is less than 0.8 V or less than 3.2 mA, the input line is deemed to be disconnected, and the burnout detection function is activated. Once the burnout detection function is activated, the conversion data is set to 7FFF Hex.

The time required to activate or cancel the burnout detection function is the same as the time required for conversion.

If input returns to the convertible range, the burnout detection function will be cancelled automatically, and normal data conversion will be resumed.

Precautions on Using Shared Power Supply for Input Devices

If the power supply is shared by input devices, and a disconnection occurs during voltage input, the status of the circuit becomes as shown in the follow-

ing figure. (There is no effect during current input, even if the power supply is shared.)

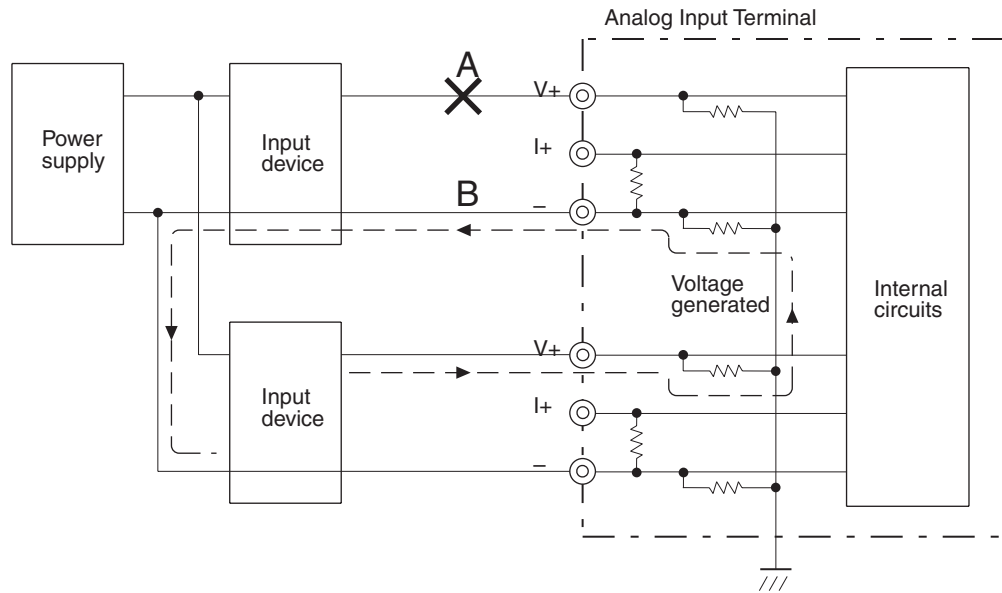

When portion A in the above diagram is disconnected, the sneak circuit indicated by \rightarrow will be formed. As a result, despite the disconnection, a voltage equivalent to 1/2 to 1/3 of the output of the connected input device is generated at the disconnected input device. (The same is true if portion B is disconnected.) When this kind of voltage is generated, the burnout detection function may fail to activate.

For voltage input, either do not have the power supply shared by the input devices, or use an isolator for each input.

AD Conversion Data

	15	14	13	12	11	10	9	8	7	6	5	4	3	2	1	0	Bit
First word	Input 0 AD conversion data																
First word +1	Input 1 AD conversion data																
First word +2	Input 2 AD conversion data																
First word +3	Input 3 AD conversion data																

When the AD conversion data becomes negative, it is expressed as 2's complement. The NEG instruction can be used to obtain the absolute value from this 2's complement.

Conversion Time

AD conversion data is updated every 1 ms for each point.

SRT2-AD04 Dimensions

The following diagram shows the dimensions for the SRT2-AD04. All dimensions are in mm.

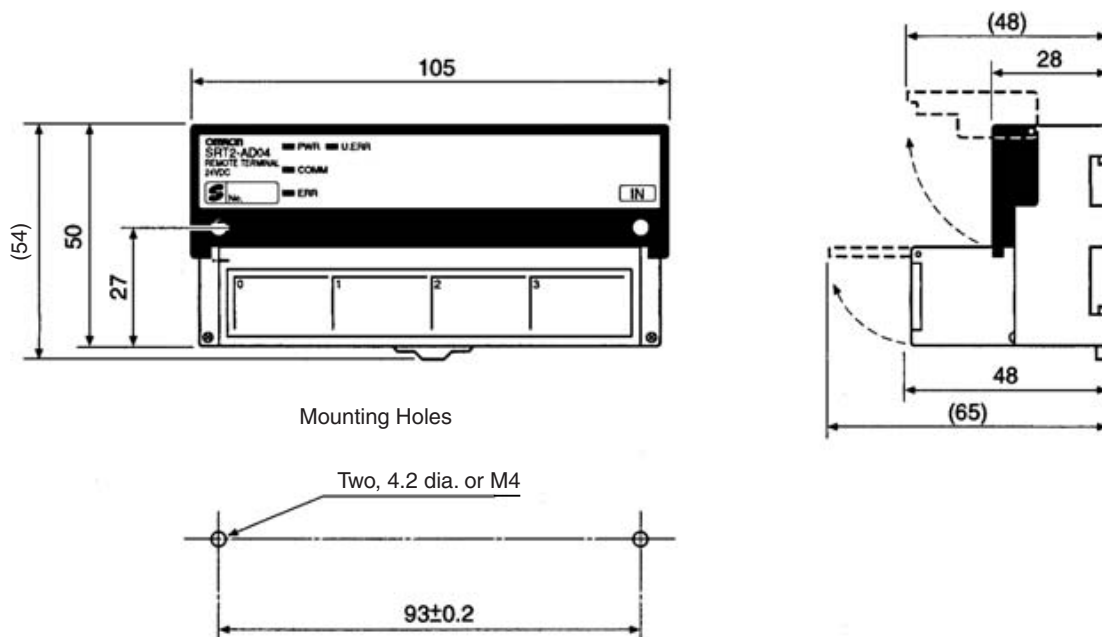

Note To prevent damage from static electricity, mount the Unit where it cannot be touched accidentally.

5-8 Analog Output Terminals

5-8-1 SRT2-DA02 Analog Output Terminal

Note Do not connect the Analog Output Terminal to any of the following incompatible Master Units or incorrect data may be transmitted.

PLC	Incompatible Master Units	Compatible Master Units
CS-series, C200HX/ C200HG/C200HE-(Z)E, and C200HS	C200HW-SRM21	C200HW-SRM21-V1
CS-series	---	CS1W-SRM21
CJ-series	---	CJ1W-SRM21
CQM1	CQM1-SRM21	CQM1-SRM21-V1
SRM1 (Integrated with CPU Unit)	SRM1-C0□ SRM1-C0□-V1	SRM1-C0□-V2
CPM2C-S (Integrated with CPU Unit)	---	All Units

The Analog Output Unit is also incompatible with the following Master Units:
 3G8B3-SRM0□ CompoBus/S VME Board
 C200PC-ISA□2-SRM SYSMAC Board
 SDD-CS1 NKE Corporation UNI-WIRE Send Unit

Specifications

The following tables show the ratings and output specifications for the SRT2-DA02.

General Specifications

Item	Specification
Model	SRT2-DA02
Output points	2 or 1 points (switchable using DIP switch) (2 or 1 words are allocated to the Master.)
Power supply type	Network power supply
Communications power supply voltage	14 to 26.4 V DC (Power cannot be supplied from the communications cable)
Current consumption	Communications power: 170 mA max.
Noise immunity	±1.5 kVp-p with a pulse width of 0.1 to 1 μs and a rise time of 1 ns (via impulse noise simulator)
Vibration resistance	10 to 55 Hz, 1.0-mm double amplitude
Shock resistance	200 m/s ²
Dielectric strength	500 V AC (between insulated circuits)
Insulation resistance	20 MΩ min. at 250 V DC (between insulated circuits)
Ambient temperature	Operating: -10 to 55°C Storage: -25 to 65°C
Ambient humidity	Operating: 25% to 85% (with no condensation) Storage: 25% to 85% (with no condensation)
Operating environment	No corrosive gases
Mounting method	M4 screws or 35-mm DIN track mounting
Mounting strength	50 N Track direction: 10 N
Terminal strength	Pulling: 50 N
Weight	Approx. 100 g

Output Specifications

Item	Specification	
	Voltage output	Current output
Output signal range	0 to 5 V 1 to 5 V 0 to 10 V -10 to 10 V	4 to 20 mA
	Output signal range is set separately for Output 0 and Output 1.	
Allowable load resistance of external output	5 k Ω min.	600 Ω max.
External output impedance	0.5 Ω max.	---
Resolution	1/6,000 (Full scale)	
General precision	25°C	±0.4%FS
	0 to 55°C	±0.8%FS
Conversion time	2 ms/2 points (2 outputs) or 2 ms/1 point (1 output)	
DA conversion input data	Binary data -10 to 10 V: Full scale F448 to 0 to 0BB8 Hex Other: Full scale 0000 to 1770 Hex	
Insulation method	Between analog output and communications line: Photo-coupler Between each analog output signal: Non-insulated	

Slave Components

The following diagram shows the main components of the SRT2-DA02 Analog Output Terminal. The functions of these components are described below.

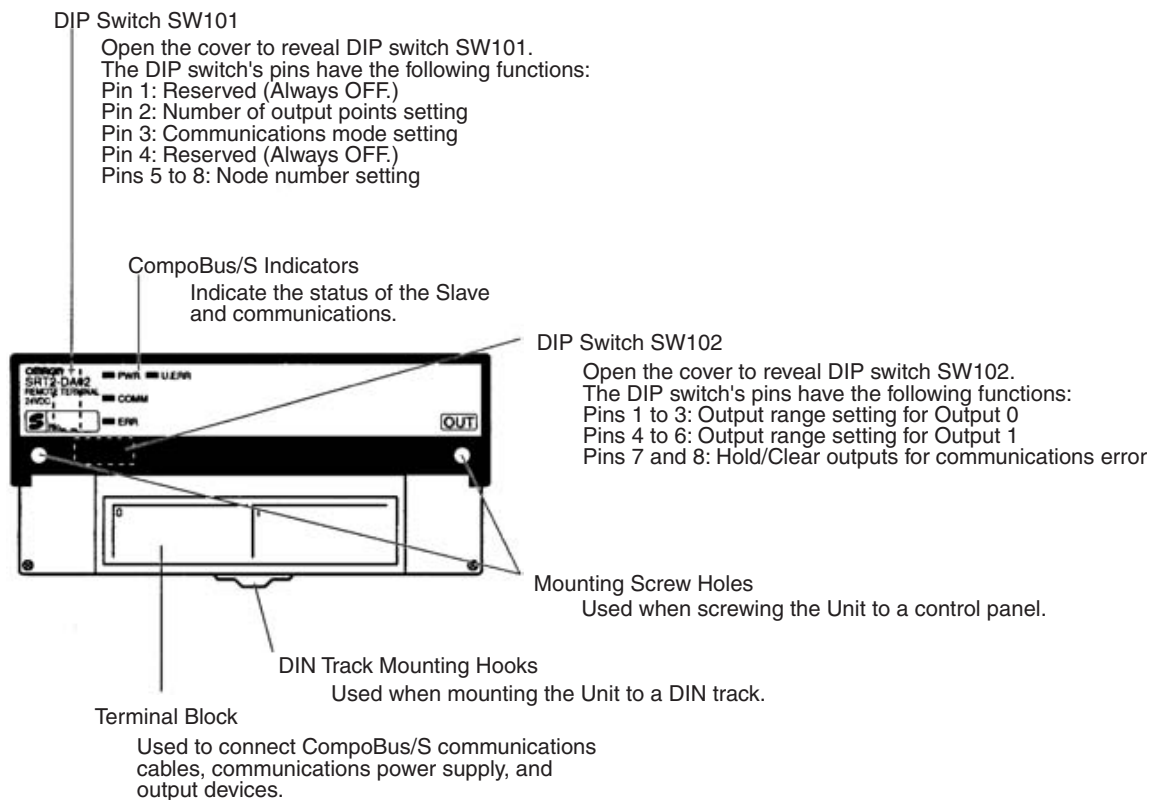

Indicators

The following table shows the meaning of the indicators.

Indicator	Status	Meaning
PWR (green)	ON	The communications power supply is ON.
	OFF	The communications power supply is OFF.
COMM (yellow)	ON	Normal communications
	OFF	A communications error has occurred or the Unit is in standby status.
ERR (red)	ON	A communications error has occurred.
	OFF	Normal communications or the Unit is in standby status.
U.ERR (red)	ON	An error has occurred in the Unit.
	OFF	Normal communications or the Unit is in standby status.

DIP Switches

Always turn OFF the Slave before changing DIP switch settings.

SW101

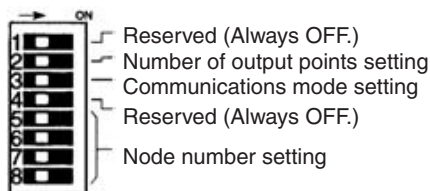

Pin 1	Always set to OFF.
--------------	--------------------

Pin 2	Number of output points setting
OFF	2 points (Factory setting)
ON	1 point (Output 0 valid)

Pin 3	Communications mode setting
OFF	High-speed Communications Mode (Factory setting)
ON	Long-distance Communications Mode

Pin 4	Always set to OFF.

Note Make sure that the communications mode of the Slave is the same as that of the Master Unit. If the communications modes are not the same, normal communications with the Master Unit will not be possible. The operating status of the Slave can be verified with LED indicators. Refer to 6-5-1 *Indicators* for details.

Node Number Setting

Set the node number with pins 5 through 8, as shown in the following table.

Node number	Pin 5 (8)	Pin 6 (4)	Pin 7 (2)	Pin 8 (1)
0	OFF	OFF	OFF	OFF
1	OFF	OFF	OFF	ON
2	OFF	OFF	ON	OFF
3	OFF	OFF	ON	ON
4	OFF	ON	OFF	OFF
5	OFF	ON	OFF	ON
6	OFF	ON	ON	OFF
7	OFF	ON	ON	ON
8	ON	OFF	OFF	OFF
9	ON	OFF	OFF	ON
10	ON	OFF	ON	OFF
11	ON	OFF	ON	ON
12	ON	ON	OFF	OFF
13	ON	ON	OFF	ON
14	ON	ON	ON	OFF
15	ON	ON	ON	ON

A single Analog Output Terminal is allocated either 32 points or 16 points. Points are assigned as shown in the following table. Note that when CQM1 Master Unit is used in 4-point mode, an Analog Output Terminal cannot be connected.

Allocated points	Node number setting	Node number actually used
32 points (2 outputs)	Odd	Node number setting – 1 to node number setting + 2
	Even	Node number setting to node number setting + 3
16 points (1 output)	Odd	Node number setting – 1 to node number setting
	Even	Node number setting to node number setting + 1

SW102



Output range setting Output setting for communications error

Pin 1	Pin 2	Pin 3	Range setting for Output 0
Pin 4	Pin 5	Pin 6	Range setting for Output 1
OFF	OFF	OFF	0 to 5 V (Factory setting)
ON	OFF	OFF	1 to 5 V
OFF	ON	OFF	0 to 10 V
ON	ON	OFF	-10 to 10 V
OFF	OFF	ON	4 to 20 mA
Do not set to any values but those given above.			

Pin 7	Pin 8	Output setting for communications error
OFF	OFF	Clear to lower output limit (Factory setting)
OFF	ON	Clear to upper output limit
ON	OFF	0 V output (When output range is -10 to 10 V.) Clear to lower output limit (Any other time.)
ON	ON	Hold output

Note Output range is set separately for Output 0 and Output 1. An example is shown below.

Output 0: 4 to 20 mA (Pins 1, 2, 3 = OFF, OFF, ON)
 Output 1: 1 to 5 V (Pins 4, 5, 6 = ON, OFF, OFF)

Internal Circuits

The following diagram shows the internal circuits for the SRT2-DA02.

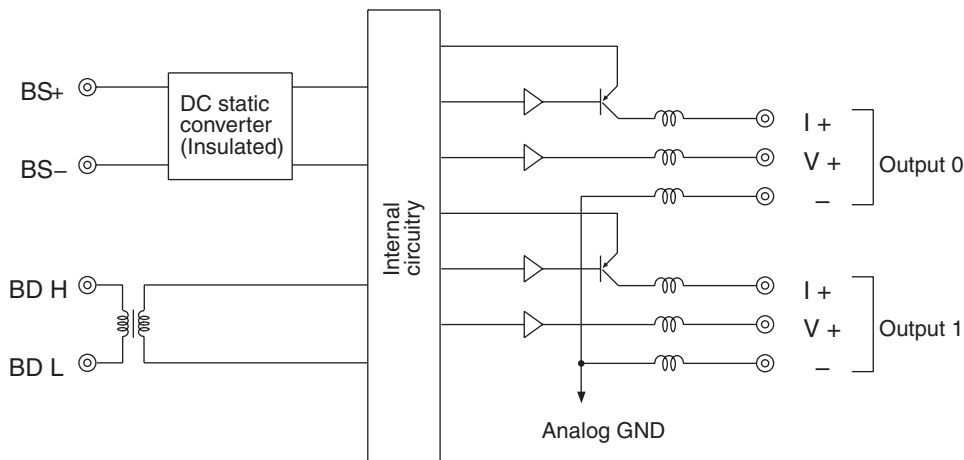

Terminal Block

Install the following M3 crimp terminals on the signal wires and connect them to the terminal block.



Note Tighten the terminal block screws to the specified tightening torque of 0.5 N·m.

The following diagram shows the terminal block for the SRT2-DA02.

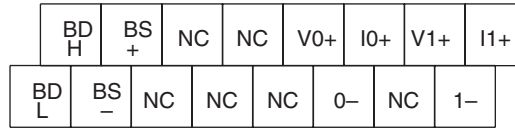

Wiring

Wire the connector terminals of the Analog Output Terminal as shown below according to voltage output or current output.

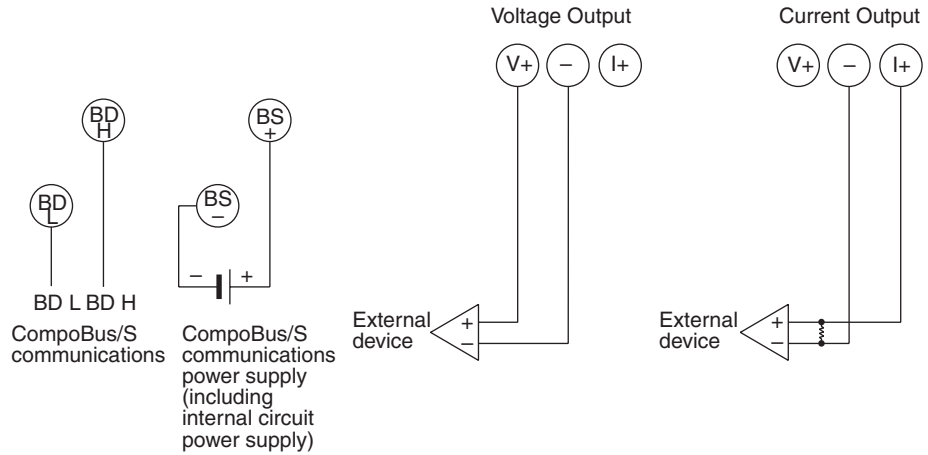

Output Range and Conversion Data

The digital values that are input are converted to analog data according to the output range.

1 to 5 V

Values 0000 to 1770 Hex (0 to 6000) correspond to voltages between 1 and 5 V. The output range is 0.8 to 5.2 V.

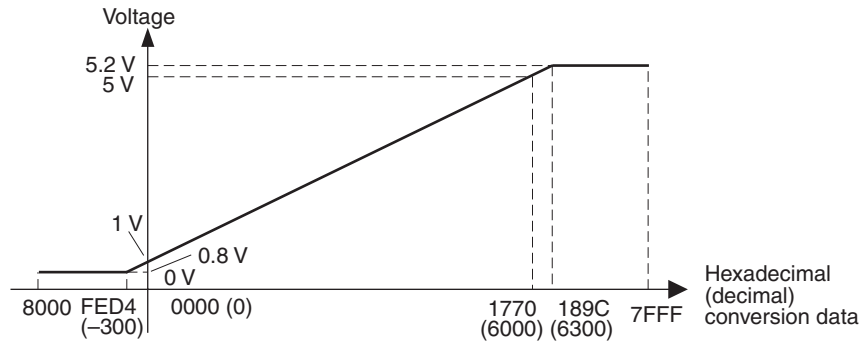

0 to 5 V

Values 0000 to 1770 Hex (0 to 6000) correspond to voltages between 0 and 5 V. The output range is -0.25 to 5.25 V.

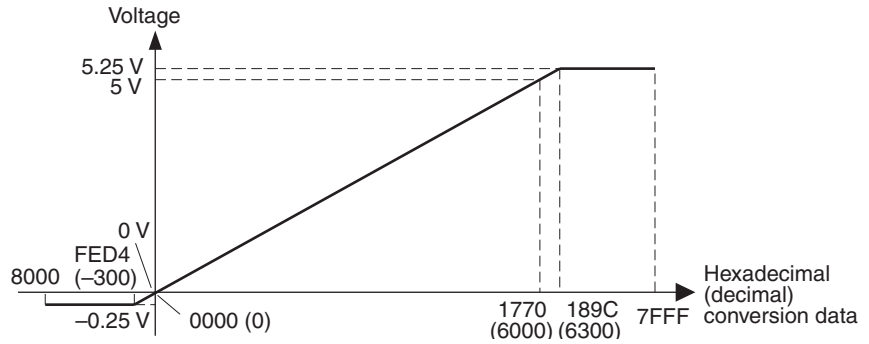

0 to 10 V

Values 0000 to 1770 Hex (0 to 6000) correspond to voltages between 0 and 10 V. The output range is -0.5 to 10.5 V.

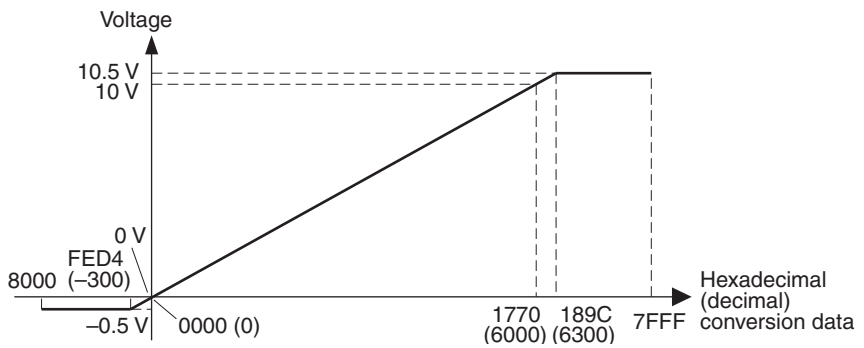

-10 to 10 V

Values F448 to 0BB8 Hex (-3000 to 3000) correspond to voltages between -10 and 10 V. The output range is -11 to 11 V. Negative voltages are specified as 2's complement (16 bits).

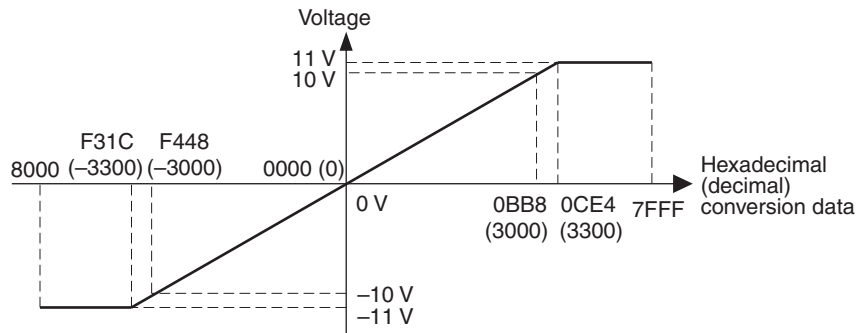

4 to 20 mA

Values 0000 to 1770 Hex (0 to 6000) correspond to currents between 4 and 20 mA. The output range is 3.2 to 20.8 mA.

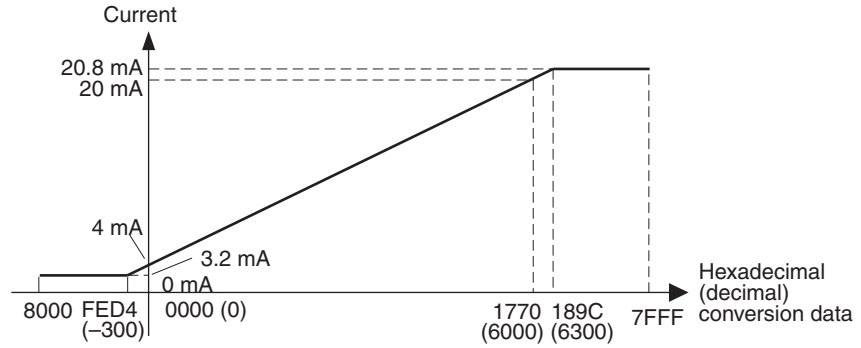

Switching between 2 and 1 Outputs

It is possible to restrict the number of outputs with pin 2 of DIP switch SW101. In accordance with the number of outputs, the number of words allocated to the Analog Output Terminal in the PLC for the Master Unit will also be set to 2 words/2 points or 1 word/1 point. When the number of outputs is 2, Outputs 0 and 1 will be used; and when the number of outputs is 1, Output 0 will be used.

Output Data During Communications Error

Pins 7 and 8 of DIP switch SW102 are used to select one of the following methods for processing output data when a communications error occurs in the CompoBus/S System.

Pin 7 OFF, Pin 8 OFF: Clear to lower limit value

Pin 7 OFF, Pin 8 ON: Clear to upper limit value

Pin 7 ON, Pin 8 OFF: Clear to 0 V (when voltage range is -10 to 10 V.)
Clear to lower limit value (All other times.)

Pin 7 ON, Pin 8 ON: Hold the value immediately preceding error

When the pins are set at Low Clear, High Clear, or 0 V, output data will become as shown in the following table.

Output range	Pin 7 OFF, Pin 8 OFF	Pin 7 OFF, Pin 8 ON	Pin 7 ON, Pin 8 OFF
0 to 5 V	-0.25 V	5.25 V	-0.25 V
1 to 5 V	0.8 V	5.2 V	0.8 V
0 to 10 V	-0.5 V	10.5 V	-0.5 V
-10 to 10 V	-11 V	11 V	0 V
4 to 20 mA	3.2 mA	20.8 mA	3.2 mA

DA Conversion Data

In the Master Unit, DA conversion data should be output as shown in the following diagram.

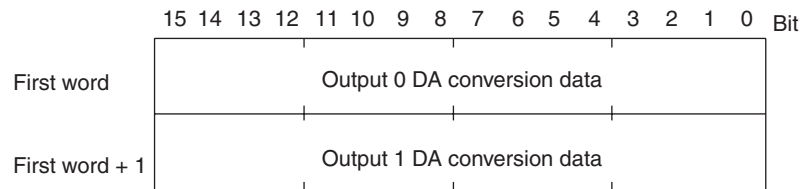

To output a negative voltage is output, specify DA conversion data as 2's complement. The NEG instruction can be used to obtain the 2's complement from the absolute value.

Conversion Time

DA conversion data is updated every 2 ms irrespective of the number of output points.

SRT2-DA02 Dimensions

The following diagram shows the dimensions for the SRT2-DA02. All dimensions are in mm.

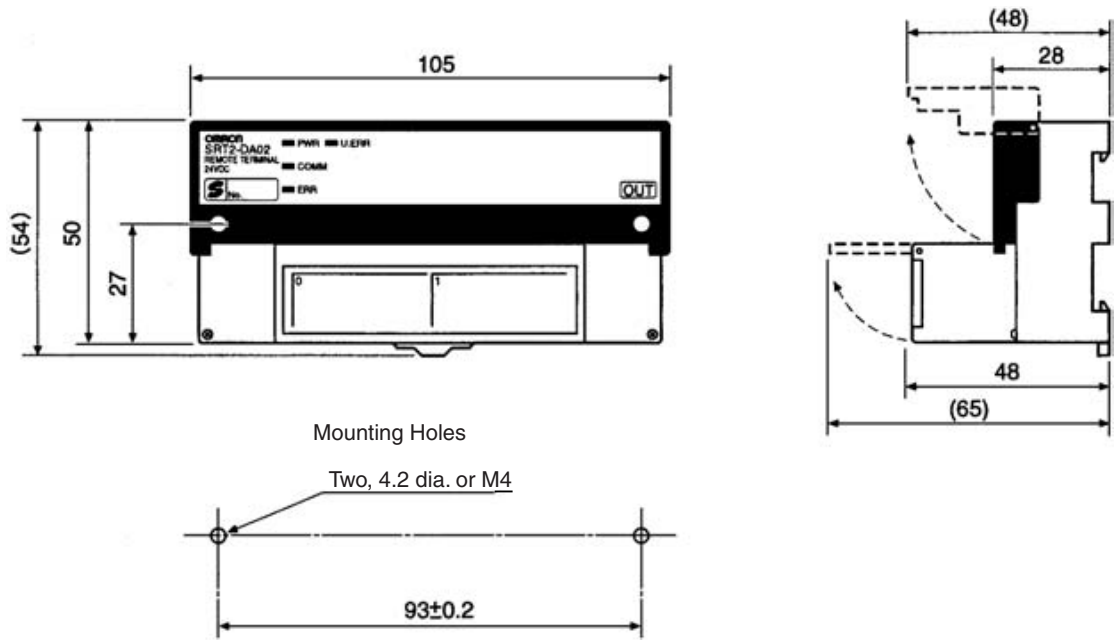

Note To prevent damage from static electricity, mount the Unit where it cannot be touched accidentally.

5-9 I/O Link Units for CPM1A and CPM2A

5-9-1 CPM1A-SRT21 I/O Link Unit for CPM1A and CPM2A

Specifications

The following table shows the ratings and I/O specifications for the CPM1A-SRT21.

Ratings

Item	Specification
Model	CPM1A-SRT21
I/O points	8 input points, 8 output points (All the I/O points use the same node number. I/O is performed only with I/O memory of CPM1A/CPM2A, not with external devices.)
Connection to CPM1A/CPM2A	Connect expansion I/O connecting cable to the expansion connector of the CPU Unit or the Expansion Unit.
Power supply type	---
Communications power supply and internal circuits power supply	Supplied from CPM1A or CPM2A CPU Unit. (See note.)
Vibration resistance	Conforming to JIS C0911 10 to 57 Hz with single-amplitude of 0.075 mm 57 to 150 Hz with fixed acceleration of 9.8 m/s ² 80 minutes each in X, Y, and Z directions (8 minutes per sweep × 10 sweeps = 80 minutes)
Shock resistance	Conforming to JIS C0912 Peak acceleration of 147 m/s ² 3 times each in X, Y, and Z directions
Ambient temperature	Operating: 0 to 55°C (with no icing or condensation) Storage: -20 to 75°C (with no icing or condensation)
Ambient humidity	Operating: 10% to 90% (with no condensation) Storage: 10% to 90% (with no condensation)
Operating environment	No corrosive gases
Node number settings	The node number is set on a DIP switch. (Set the node number before turning ON the CPM1A or CPM2A CPU Unit.)
Weight	Approx. 200 g

Note CompoBus/S communications and common I/O terminals are not used.

Slave Components

The following diagram shows the main components of the CPM1A-SRT21 I/O Link Unit for CPM1A/CPM2A. The functions of these components are described below.

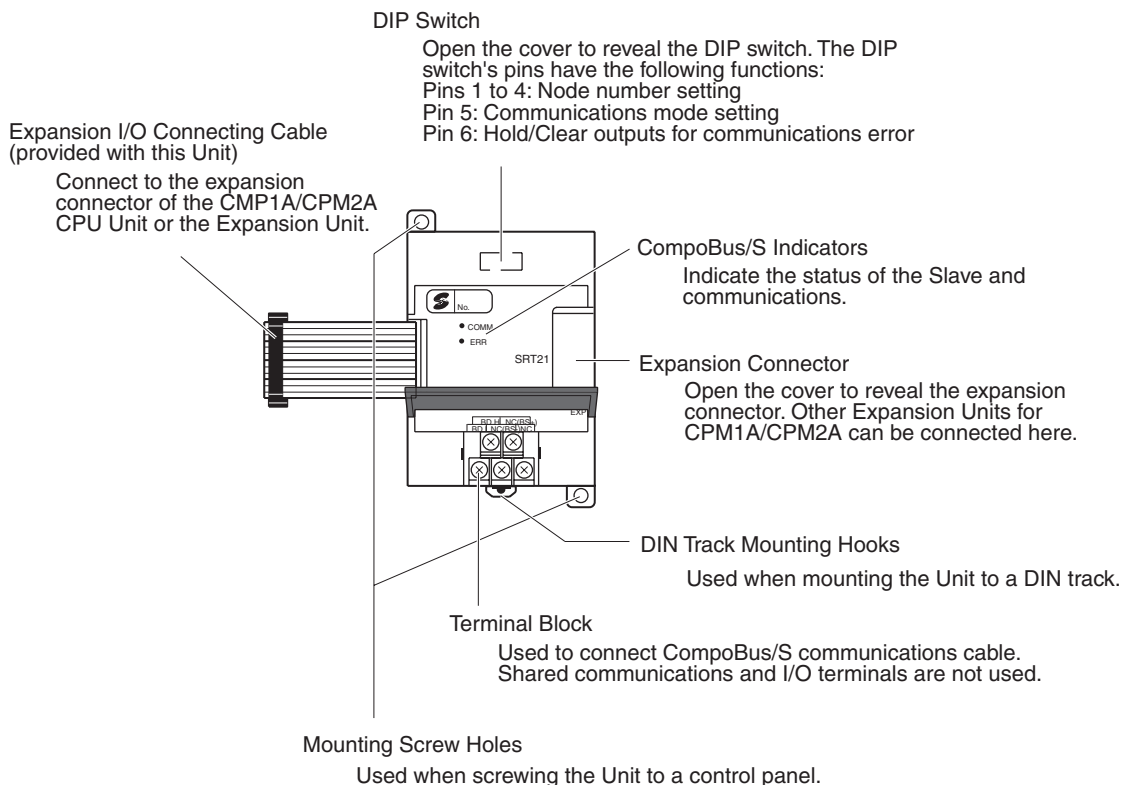

Indicators

The following table shows the meaning of the indicators.

Indicator	Name	Status	Meaning
COMM (yellow)	Communications	ON	Normal communications.
		OFF	A communications error has occurred or the Unit is in standby status.
ERR (red)	Communications error	ON	A communications error has occurred.
		OFF	Normal communications or the Unit is in standby status.

DIP Switch

Always turn OFF the CPM1A or CPM2A CPU Unit before changing DIP switch settings.

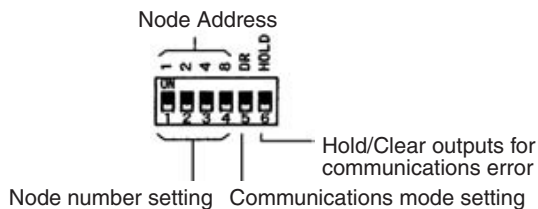

Node Number Setting

Set the node number with pins 1 through 4, as shown in the following table.

Node number	Pin 4 (8)	Pin 3 (4)	Pin 2 (2)	Pin 1 (1)
0	OFF	OFF	OFF	OFF
1	OFF	OFF	OFF	ON
2	OFF	OFF	ON	OFF

Node number	Pin 4 (8)	Pin 3 (4)	Pin 2 (2)	Pin 1 (1)
3	OFF	OFF	ON	ON
4	OFF	ON	OFF	OFF
5	OFF	ON	OFF	ON
6	OFF	ON	ON	OFF
7	OFF	ON	ON	ON
8	ON	OFF	OFF	OFF
9	ON	OFF	OFF	ON
10	ON	OFF	ON	OFF
11	ON	OFF	ON	ON
12	ON	ON	OFF	OFF
13	ON	ON	OFF	ON
14	ON	ON	ON	OFF
15	ON	ON	ON	ON

- Note**
1. All the 8 input and 8 output points use the same node number.
 2. The actual node number setting range depends on the type of PLC in which the Master is mounted as well as the Master's settings. Refer to 2-1 *Communications Specifications* for details.

Communications Mode Settings

The following communications modes are set with pin 5.

Pin 5 (DR)	Communica- tions mode	Communica- tions distance	Communica- tions baud rate	Communica- tions cycle time
OFF	High-speed Com- munications Mode	100 m max.	750 kbps	0.5 or 0.8 ms
ON	Long-distance Communications Mode (see note 1)	500 m max.	93.75 kbps	4.0 or 6.0 ms

- Note**
1. Only the C200HW-SRM21-V1, CQM1-SRM21-V1, CPM2C-S, and SRM1-C0□-V2 Master Units can use Long-distance Communications Mode.
 2. Make sure that the communications mode of the Slave is the same as that of the Master Unit. If the communications modes are not the same, normal communications with the Master Unit will not be possible. The operating status of the Slave can be verified with LED indicators. Refer to 6-5-1 *Indicators* for details.

Hold/Clear Outputs for Communications Error

Pin 6 is used to set the output data status when a communications error occurs, as shown in the following table.

Pin 6 (HOLD)	Setting
OFF	Clear output status.
ON	Maintain output status.

Terminal Arrangement and Wiring

The following diagram shows the terminal arrangement and wiring for the CPM1A-SRT21.

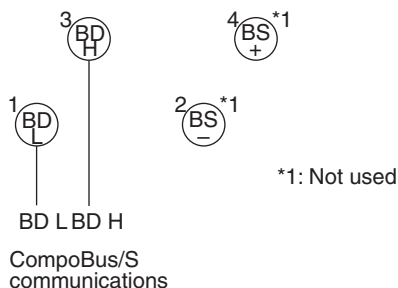

When viewed from the CPM1A or CPM2A CPU Unit, the 8 input and 8 output points under the CompoBus/S I/O Link Unit are allocated to the I/O memory (input and output bits) of the CPU Unit, as is the case with Expansion I/O Units. However, actual I/O operation is not performed for the I/O memory of the CPM1A or CPM2A CPU Unit, but it is performed for the I/O memory of the CPU Unit in which the CompoBus/S Master Unit is mounted.

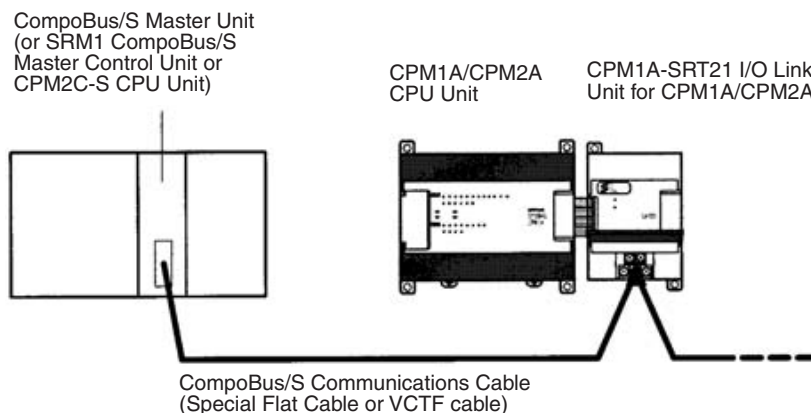

Allocation to CPM1A/CPM2A I/O Bits

As with other Expansion I/O Units for the CPM1A and CPM2A, both input and output bits for the I/O Link Unit start with the word following the last word allocated to the CPM1A or CPM2A CPU Unit or the previous Expansion I/O Unit to which it is connected. If the last input word allocated to the CPM1A/CPM2A CPU Unit or the previous Expansion Unit is word m, and the last output word allocated to that Unit is word n, word allocations are as shown in the following figure.

I/O Link Unit for CPM1A/CPM2A

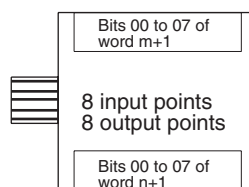

For example, an I/O Link Unit for CPM1A/CPM2A can be connected to the first 30-point I/O CPM2A CPU Unit as shown in the following figure.

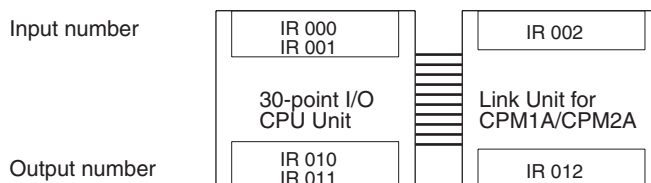

Allocation to Master CPU Unit

The 8 input and 8 output points allocated to the I/O memory of the CPM1A or CPM2A CPU Unit are allocated to the Special I/O Unit data area of the Master CPU Unit according to the node number.

Both 8 input and 8 output points use the same node number.

For example, if the range of node numbers IN0 to IN7 and OUT0 to OUT7 is set, and node number 0 is used, data will be input from bits 00 to 07 of word n (Output Slave 0) and data will be output to bits 00 to 07 of word n + 4 (Input Slave 0).

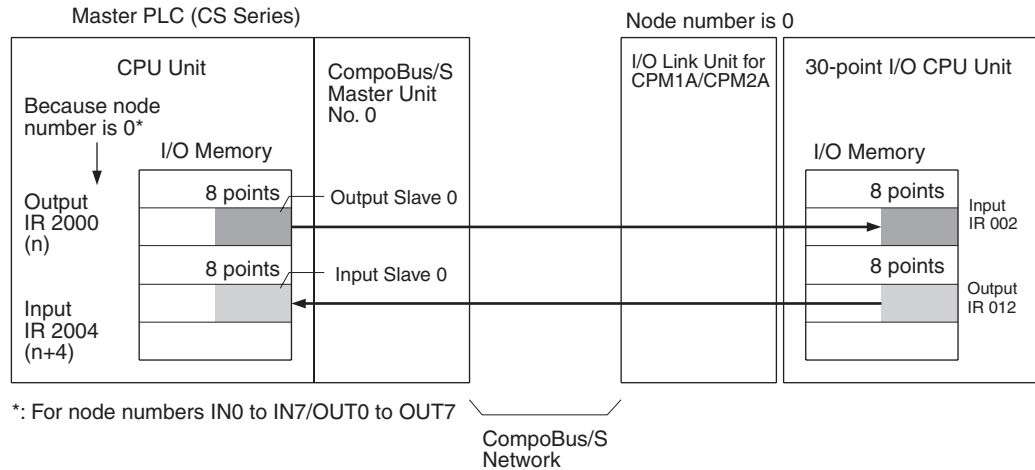

5-10 I/O Link Units for CPM2C

5-10-1 CPM2C-SRT21 I/O Link Unit for CPM2C

Specifications

The following table shows the ratings and I/O specifications for the CPM2C-SRT21.

Ratings

Item	Specification
Model	CPM2C-SRT21
I/O points	8 input points, 8 output points (All the I/O points use the same node number. I/O is performed only with I/O memory of CPM2C, not with external devices. One input word and output word of CPM2C are allocated.)
Connection to CPM2C	Connect expansion I/O connecting cable to the expansion connector of the CPU Unit or the Expansion Unit. (Up to 5 Units are connectable.)
Power supply type	---
Communications power supply and internal circuits power supply	Supplied from CPM2C CPU Unit. (See note.)
Node number settings	The node number is set on a DIP switch. (Set the node number before turning ON the CPM2C CPU Unit.)
Weight	Approx. 150 g

Note CompoBus/S communications power supply is not connected.

Standard Specifications

Conform to standard CPM2C specifications.

Slave Components

The following diagram shows the main components of the CPM2C-SRT21 I/O Link Unit. The functions of these components are described below.

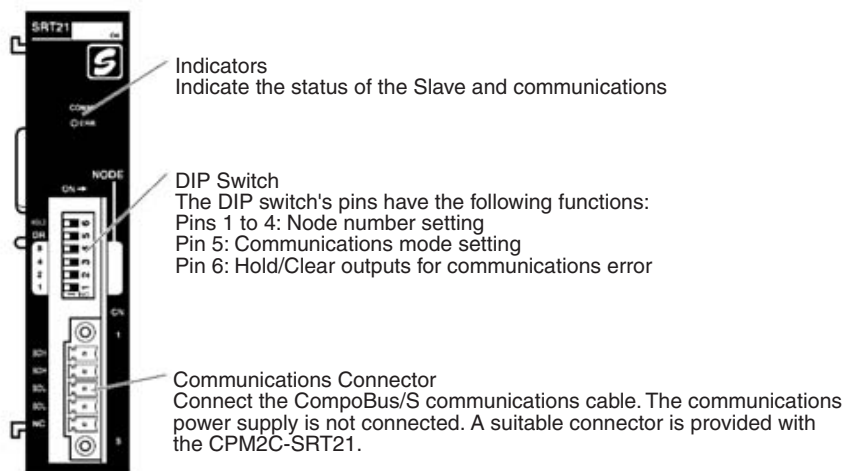

Indicators

The following table shows the meaning of the indicators.

Indicator	Name	Status	Meaning
COMM (yellow)	Communications	ON	Normal communications
		OFF	A communications error has occurred or the Unit is in standby status.
ERR (red)	Communications error	ON	A communications error has occurred.
		OFF	Normal communications or the Unit is in standby status.

DIP Switch

Always turn OFF the CPM2C CPU Unit before changing DIP switch settings.

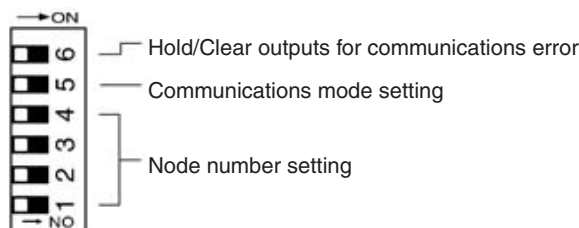

Note Always turn OFF the power supply to the CPM2C before setting the DIP switch.

Node Number Setting

Set the node number with 1 through 4, as shown in the following table.

Node number	SW4 (8)	SW3 (4)	SW2 (2)	SW1 (1)	Node number	SW 4 (8)	SW 3 (4)	SW2 (2)	SW1 (1)
0	OFF	OFF	OFF	OFF	8	ON	OFF	OFF	OFF
1	OFF	OFF	OFF	ON	9	ON	OFF	OFF	ON
2	OFF	OFF	ON	OFF	10	ON	OFF	ON	OFF
3	OFF	OFF	ON	ON	11	ON	OFF	ON	ON
4	OFF	ON	OFF	OFF	12	ON	ON	OFF	OFF
5	OFF	ON	OFF	ON	13	ON	ON	OFF	ON
6	OFF	ON	ON	OFF	14	ON	ON	ON	OFF
7	OFF	ON	ON	ON	15	ON	ON	ON	ON

- Note**
1. All 8 input and 8 output points use the same node number.
 2. The actual node number setting range depends on the PLC model in which the Master is mounted as well as the Master's settings. Refer to 2-1 Communications Specifications for details.

Communications Mode Settings

The following communications modes are set with pin 5 of the DIP switch.

Pin 5 (DR)	Communications mode	Communications distance	Communications baud rate	Communications cycle time
OFF	High-speed Communications Mode	100 m max.	750 kbps	0.5 or 0.8 ms
ON	Long-distance Communications Mode	500 m max.	93.75 kbps	4.0 or 6.0 ms

- Note**
1. Only the C200HW-SRM21-V1, CQM1-SRM21-V1, SRM1-CO□-V2, and CPM2C-S Master Units can be Long-distance Communications Mode.
 2. Make sure that the communications mode of the Slave is the same as that of the Master Unit. If the communications modes are not the same, normal communications with the Master Unit will not be possible. The operating status of the Slave can be verified with LED indicators. Refer to 6-5-1 Indicators for details.

Hold/Clear Outputs for Communications Error

Pin 6 is used to set the output data status when a communications error occurs, as shown in the following table.

Pin 6 (HOLD)	Setting
OFF	Clear output status
ON	Maintain output status

Terminal Arrangement and Wiring

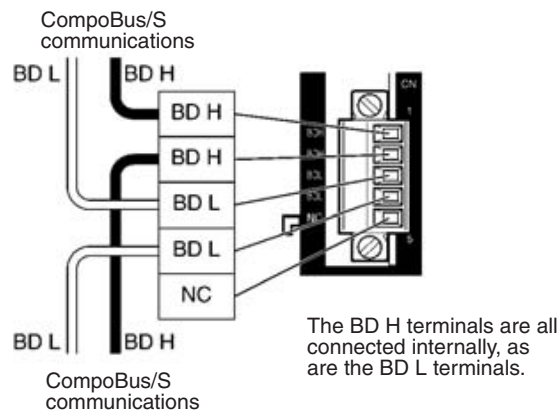

When viewed from the CPM2C CPU Unit, the 8 input and 8 output points under the CompoBus/S I/O Link Unit are allocated to the I/O memory (input and output bits) of the CPU Unit, as is the case with Expansion I/O Units. One input and one output words are allocated. Actual I/O operations are not performed for the I/O memory of the CPM2C CPU Unit, but it is performed for the

I/O Memory of the CPU Unit in which the CompoBus/S Master Unit is mounted.

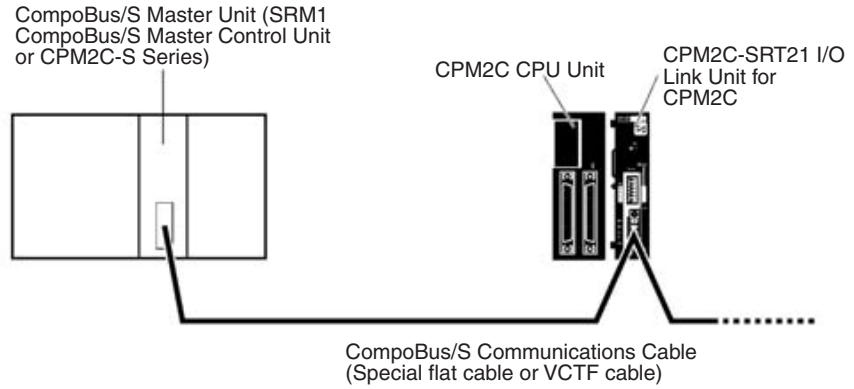

Allocation to CPM2C I/O Bits

As with other Expansion I/O Units for the CPM2C, both input and output bits for the I/O Link Unit start with the word following the last word allocated to the CPM2C CPU Unit or the previous Expansion I/O Unit to which it is connected. If the last input word allocated to the CPM2C CPU Unit or the previous Expansion Unit is word *m*, and the last output word allocated to that Unit is word *n*, word allocations are as shown in the following figure.

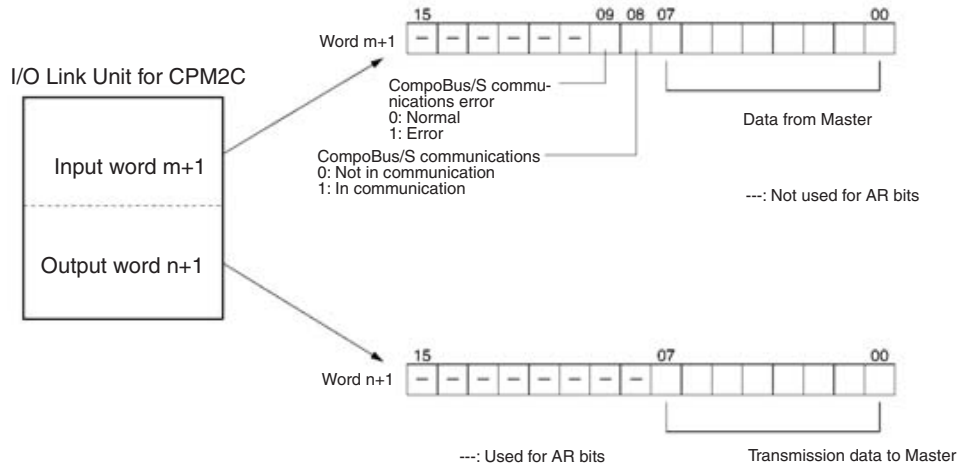

An I/O Link Unit for the CPM2C Series can be connected to the first 20-point I/O CPM2C CPU Unit as shown in the following figure.

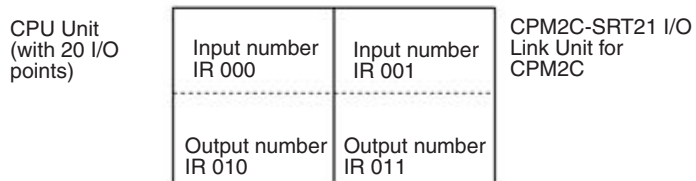

- Note**
1. Data transmissions are not synchronized for all 8 I/O points. Eight-point data simultaneously output from the Master CPU will not always reach the CPM2C CPU Unit simultaneously. Eight-point data simultaneously output from the CPM2C CPU Unit will not always reach the CPU Unit of the Master simultaneously. If 8-point data needs synchronization, write the ladder

program to read the data twice consecutively on the input side and treat the data as valid data only if the same data is read both times.

2. Output bits allocated to the I/O Link Unit for CPM2C but not used for data output can be used as work bits.
3. Allocated input bits cannot be used as work bits regardless of the input bits are used for data input or not.

Allocation to Master CPU Unit

The 8 input and 8 output points allocated to the I/O memory of the CPM2C CPU Unit will be allocated in the Special I/O Unit data area of the Master CPU Unit according to the node number. Both 8 input and 8 output points use the same node number. For example, if the range of node numbers IN0 to IN7 and OUT0 to OUT7 is set, and node number 0 is used, data will be input from bits 00 to 07 of word n (Output Slave 0) and output to bits 00 to 07 of word n + 4 (Input Slave 0).

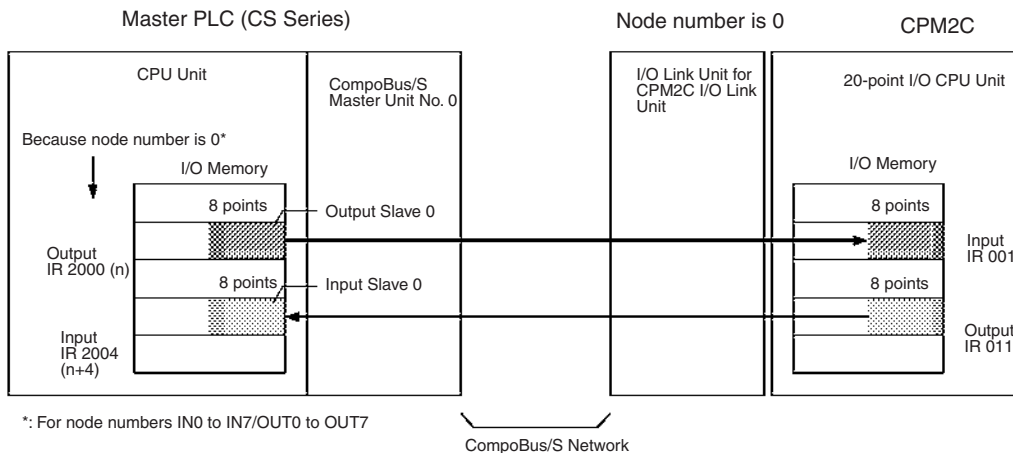

Note Input word bits 08 and 09 of the CPM2C CPU Unit are used by the I/O Link Unit for CPM2C. As an Output Slave of the Master CPU Unit, only 8 points are allocated.

5-11 Sensor Amplifier Terminals

5-11-1 SRT1-T□D04S Sensor Amplifier Terminals

Combinations

Sensor Amplifier Communications Terminals

Input	Model
4 input points (1 channel × 4 units)	SRT1-TID04S
4 input points (4 channels × 1 unit)	SRT1-TKD04S

+

Sensor Amplifier Expansion Terminals

Input	Model
4 input points (1 channel × 4 units)	SRT1-XID04S
4 input points (4 channels × 1 unit)	SRT1-XKD04S

Connector Units (1 Channel Input)

Input	Specifications	Model
E3X-N Connector	General-purpose, 1 channel	E3X-NT16
	Multi-function, 1 channel	E3X-NT26
Terminal Block Unit	1 input point	E39-JID01

Connecting Unit (4 Channels Input)

Input	Specifications	Model
E3X-N Connector	Multi-function, 1 channel	E3X-NM16

Specifications

The following tables show the ratings and specifications for the SRT1-T□D04S.

Sensor Amplifier Terminals

Item	Specification			
	SRT1-TID04S	SRT1-TKD04S	SRT1-XID04S	SRT1-XKD04S
Classification	Communications		Expansion	
Connected Sensors	Total of four E3X-NT□6 or E39-JID01 (see note 1)	One E3X-NM16 (see note 1)	Total of four E3X-NT□6 or E39-JID01	One E3X-NM16
Input points (see note 2)	4 points			
Communications mode	High-speed communications mode only		---	
Power supply type	Network power supply		---	
Communications power supply voltage	14 to 26.4 V DC (see note 3)		---	
Current consumption	60 mA max. (see note 4)		10 mA max. (see note 4)	
Noise immunity	±1.5 kVp-p with a pulse width of 0.1 to 1 μs and a rise time of 1 ns (via impulse noise simulator)			
Vibration resistance	10 to 55 Hz, 1.5-mm double amplitude			
Shock resistance	200 m/s ²			
Dielectric strength	500 V AC (between insulated circuits)			
Ambient temperature	Operating: 0 to 55°C (with no icing or condensation) Storage: -20 to 65°C (with no icing or condensation)			
Ambient humidity	Operating: 35% to 85% (with no condensation) Storage: 25% to 85% (with no condensation)			
Mounting method	M4 screws or 35-mm DIN track mounting			
Mounting strength	49 N in each direction. Track direction: 10 N			
Terminal strength	Pulling: 49 N Tightening: 0.6 to 1.18 N • m			
Node number settings	The node number is set on a DIP switch. (Set the node number before turning ON the Slave.)			
Weight	70 g max.	65 g max.	45 g max.	35 g max.

- Note**
1. When adding Connector Units, use SRT1-XID04S or SRT1-XKD04S.
 2. The Sensor Amplifier Terminal is treated as a Slave with four input points if the Sensor Amplifier Communications Terminal is used alone. The combination of Sensor Amplifier Communications Terminal and Sensor Amplifier Expansion Terminal are treated as a Slave with eight input points.
 3. The communications power supply voltage must be 20.4 to 26.4 V DC if the Terminal is connected to 2-wired proximity sensors.
 4. The value doesn't include the current consumption of Connector Units.

Connector Units

E3X-N Connector Unit

Item	Specification		
	E3X-NT16	E3X-NT26	E3X-NM16
Amplifier	General-purpose	Multi-function	
Number of fiber inputs	1 channel		4 channels
Current consumption	50 mA max.		150 mA max.
Response time	500 μs max. (2.0 ms max. when connected to the SRT1-□□D04S)		

Item	Specification		
	E3X-NT16	E3X-NT26	E3X-NM16
Timer function	Not available	OFF-delay timer (fixed to 40 ms)	
Indicators	Orange LED: Lit during output operation Green LED: Lit with stable light reception or no light		
Teaching confirmation function	Indicators (red/green LED) and buzzer		
Output	Light ON and Dark ON (switch selectable)		
Ambient illumination	Sunlight: 10,000 lux max.; incandescent lamp: 3,000 lux max.		
Insulation resistance	20 M Ω min. at 500 V DC		
Dielectric strength	1,000 V AC at 50/60 Hz		
Vibration resistance	Destruction: 10 to 55 Hz, 1.5-mm double amplitude		
Shock resistance	Destruction: 500 m/s ²		
Ambient temperature	Operating: 0 to 55°C (with no icing or condensation) Storage: -20 to 65°C (with no icing or condensation)		
Ambient humidity	Operating: 35% to 85% (with no condensation) Storage: 25% to 85% (with no condensation)		
Mounting method	Connected to SRT1-□□D04S		
Mounting strength	49 N in each direction.		
Weight	30 g max.	30 g max.	60 g max.

Terminal Block Unit

Item	Specification
Model	E39-JID01
Input points	1 point
Input current	10 mA max.
ON voltage	12 V DC min. (between input terminal and external sensor power supply)
OFF voltage	4 V DC max. (between input terminal and external sensor power supply)
OFF current	1 mA max.
ON delay time	1 ms max. (connected to SRT□-□□D04S)
OFF delay time	1.5 ms max. (connected to SRT□-□□D04S)
Input indicators	LED (orange)
External sensor current capacity	50 mA max.
Vibration resistance	10 to 55 Hz, 1.0-mm double amplitude
Shock resistance	200 m/s ² (approx. 20G)
Ambient temperature	Operating: 0 to 55°C (with no icing or condensation) Storage: -20 to 65°C (with no icing or condensation)
Ambient humidity	Operating: 35% to 85% (with no condensation) Storage: 25% to 85% (with no condensation)
Mounting method	M4 screws or 35-mm DIN track mounting
Mounting strength	49 N in each direction. (But only 10 N in direction of track.)
Terminal strength	Pulling: 49 N Tightening: 0.6 to 1.18 N • m
Weight	25 g max.

Slave Components

The following diagram shows the main components of the Sensor Amplifier Terminals. The functions of these components are described below.

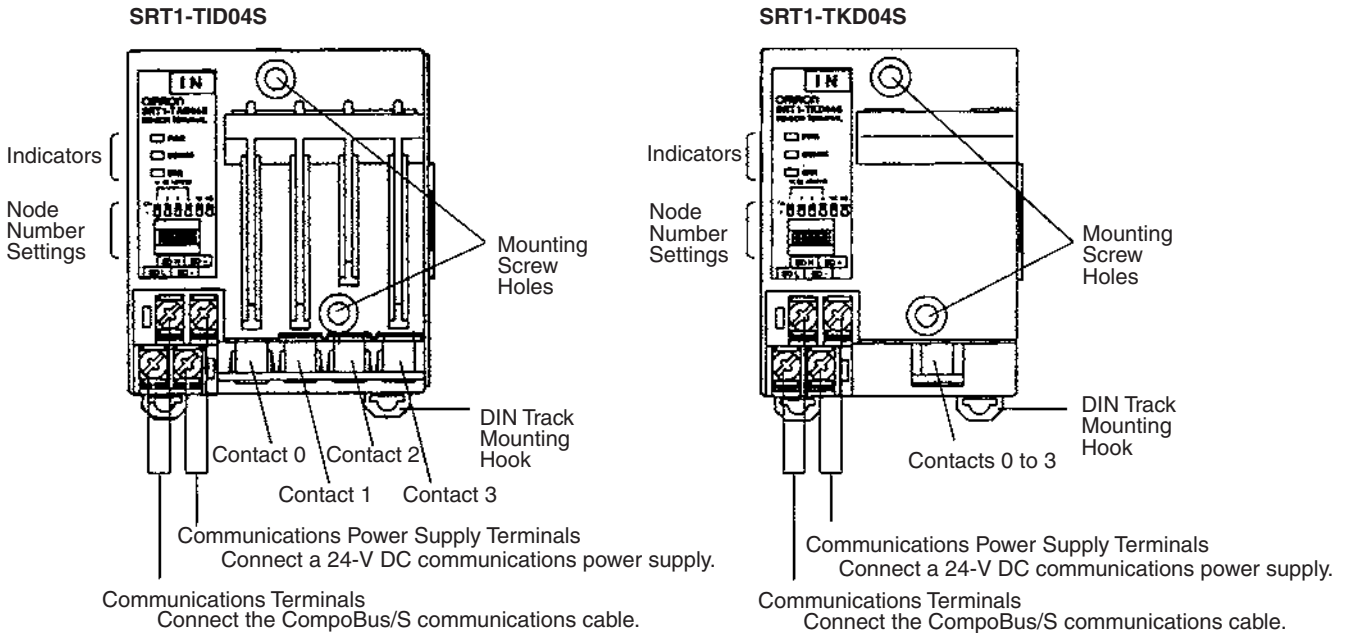

Indicators

The following table shows the meaning of the indicators.

Indicator	Name	Status	Meaning
PWR (green)	Power	ON	The communications power supply is ON.
		OFF	The communications power supply is OFF.
COMM (yellow)	Communications	ON	Normal communications.
		OFF	A communications error has occurred or the Unit is in standby status.
ERR (red)	Communications error	ON	A communications error has occurred.
		OFF	Normal communications or the Unit is in standby status.

DIP Switch

Always turn OFF the Slave before changing DIP switch settings.

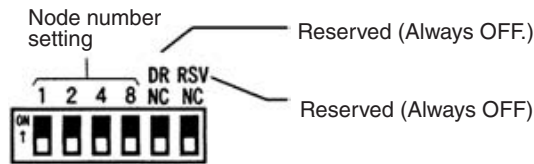

- Note**
1. Always turn OFF the Slave before changing DIP switch settings.
 2. Pins 5 and 6 must always be left OFF. Otherwise, the Unit may not function correctly.

Node Number Settings

Set the node number with pins 1 through 8, as shown in the following table.

Node number	Pin 1 (1)	Pin 2 (2)	Pin 4 (4)	Pin 8 (8)
0	OFF	OFF	OFF	OFF
1	ON	OFF	OFF	OFF
2	OFF	ON	OFF	OFF

Node number	Pin 1 (1)	Pin 2 (2)	Pin 4 (4)	Pin 8 (8)
3	ON	ON	OFF	OFF
4	OFF	OFF	ON	OFF
5	ON	OFF	ON	OFF
6	OFF	ON	ON	OFF
7	ON	ON	ON	OFF
8	OFF	OFF	OFF	ON
9	ON	OFF	OFF	ON
10	OFF	ON	OFF	ON
11	ON	ON	OFF	ON
12	OFF	OFF	ON	ON
13	ON	OFF	ON	ON
14	OFF	ON	ON	ON
15	ON	ON	ON	ON

Note The actual node number setting range depends on the type of PLC in which the Master is mounted as well as the Master's settings. Refer to *2-1 Communications Specifications* for details.

Internal Circuits

The following diagram shows the internal circuits for the E39-JID01.

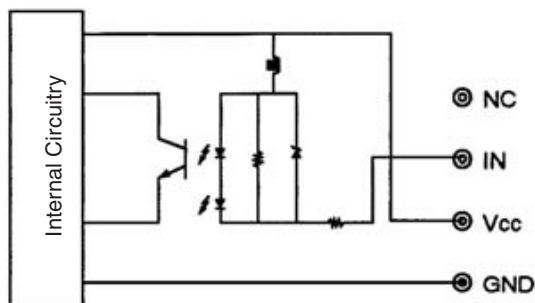

Terminal Arrangement and Wiring

The following diagram shows the terminal arrangement and wiring for the E39-JID01.

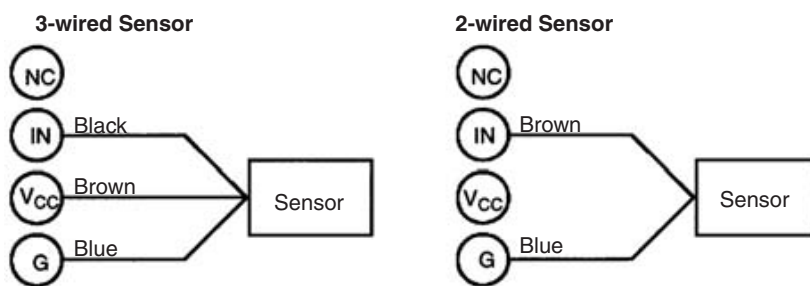

Dimensions

Sensor Amplifier Terminals

- SRT1-TID04S Sensor Amplifier Terminals (1 Channel × 4 Units)
All dimensions are in mm.

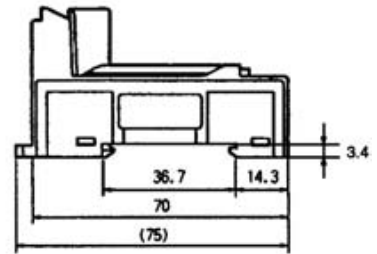
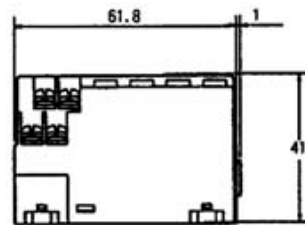
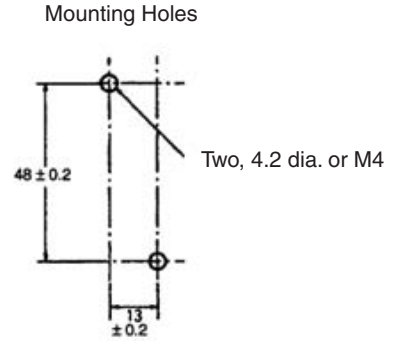
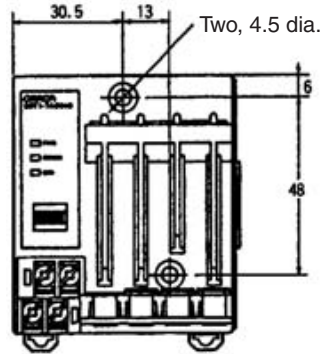

- SRT1-XID04S Sensor Amplifier Expansion Terminal (1 Channel × 4 Units)
All dimensions are in mm.

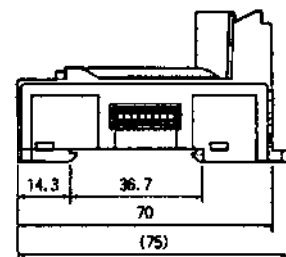
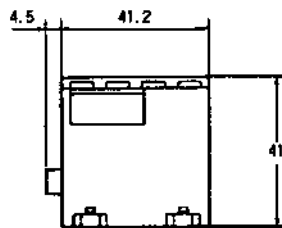
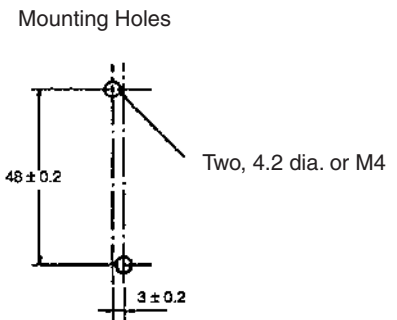
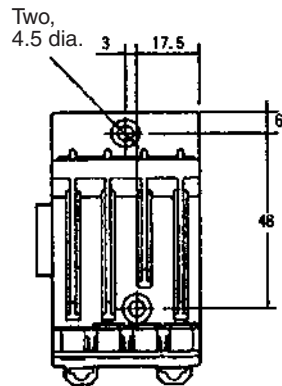

- SRT1-TKD04S Sensor Amplifier Terminal (4 Channels × 1 Unit)
All dimensions are in mm.

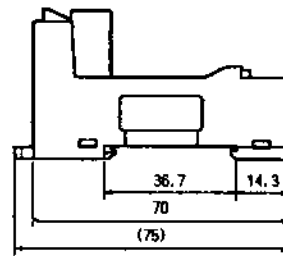
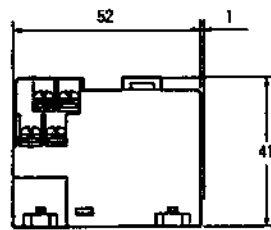
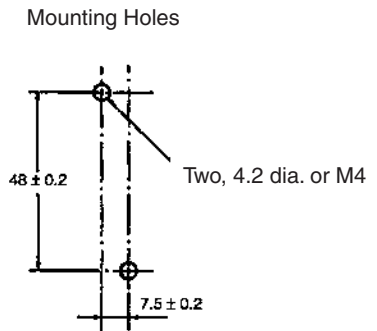
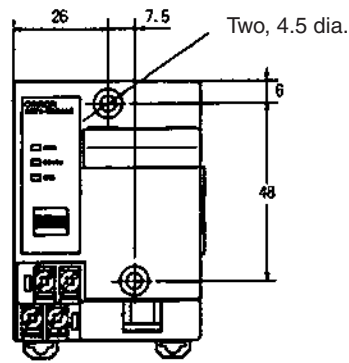

- SRT1-XKD04S Sensor Amplifier Expansion Terminal (4 Channels × 1 Unit)
All dimensions are in mm.

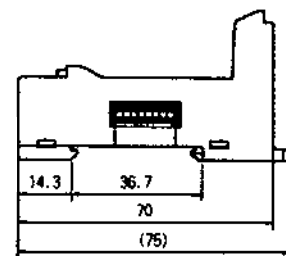
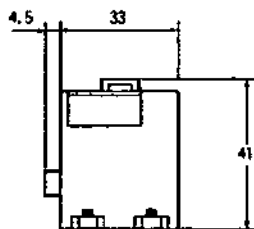
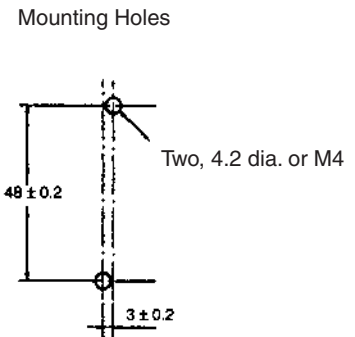
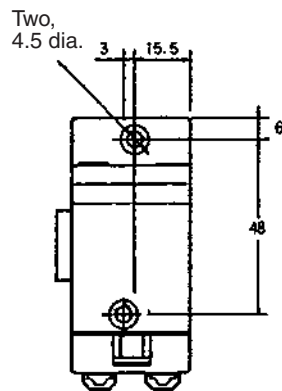

Connector Units

- E3X-NT□6 Connector (General-purpose or Multi-function, 1 Channel)
All dimensions are in mm.

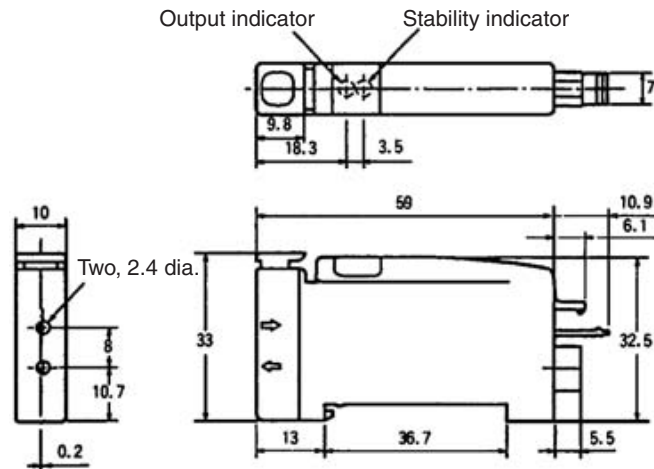

- E3X-NM16 Connector (Multi-function, 4 Channels)
All dimensions are in mm.

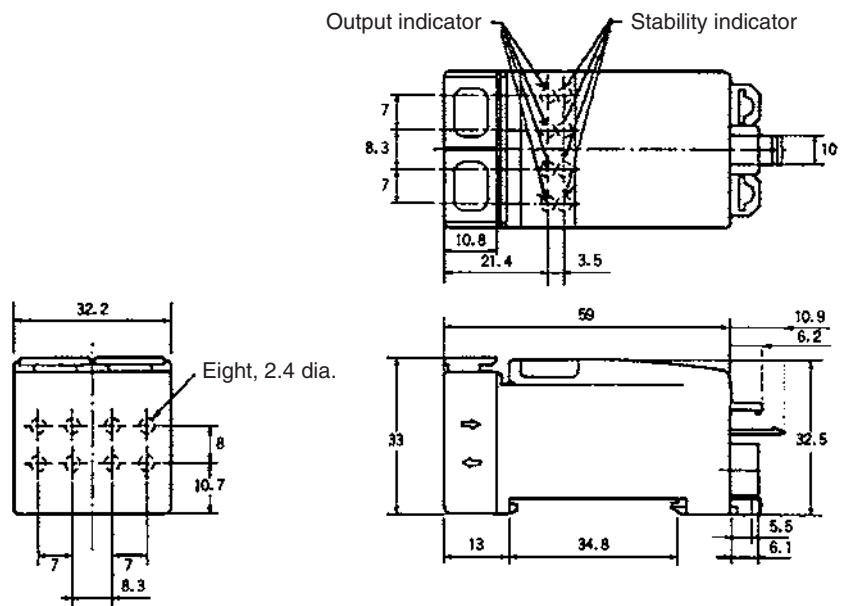

- E39-JID01 Terminal Block Unit (1 Input Point)
All dimensions are in mm.

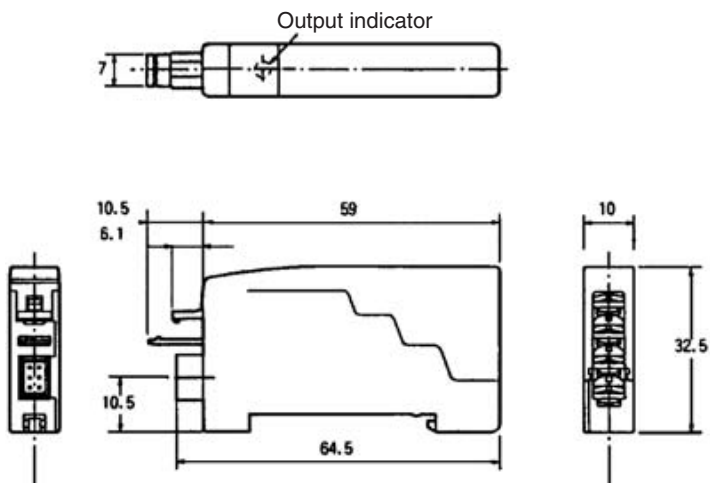

5-11-2 Sensor Amplifier Terminals

Attaching and Removing Connector Units

1 Channel × 4 Units

Sensor Amplifier Terminal	Connector Unit
SRT1/SRT2-TID04S	E3X-NT16
SRT1/SRT2-XID04S	E3X-NT26
	E39-JID01

Attaching Connector Units:

- 1,2,3...**
1. Hook Section A of the Connector Unit onto Section B of the Sensor Amplifier Terminal.
 2. Push in the Connector Unit until Section C locks inside Section D of the Sensor Amplifier Terminal.

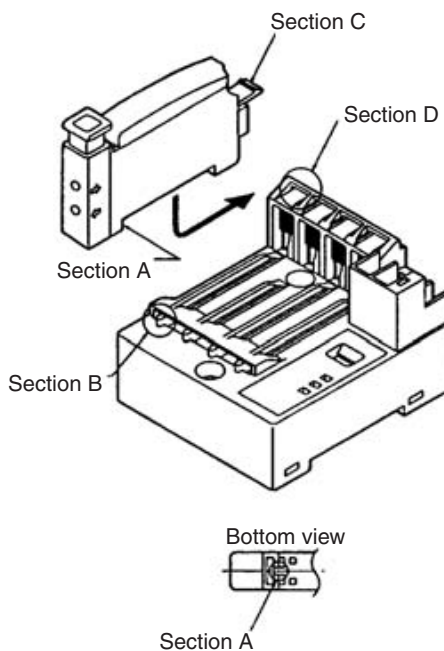

Removing Connector Units:

- 1,2,3... 1. While pushing Section D, pull the Connector Unit in direction E.
 2. When Section D releases from the lock, the Connector Unit can be removed.

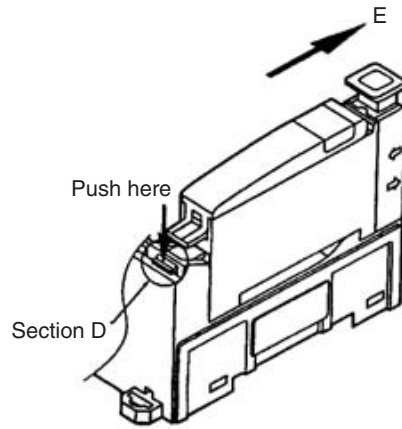

4 Channels × 1 Unit

Sensor Amplifier Terminal	Connector Unit
SRT1/SRT2-TKD04S SRT1/SRT2-XKD04S	E3X-NM16

Attaching Connector Unit:

- 1,2,3... 1. Hook Section A of the Connector Unit onto Section B of the Sensor Amplifier Terminal.
 2. Push in the Connector Unit until Section C locks inside Section D of the Sensor Amplifier Terminal.

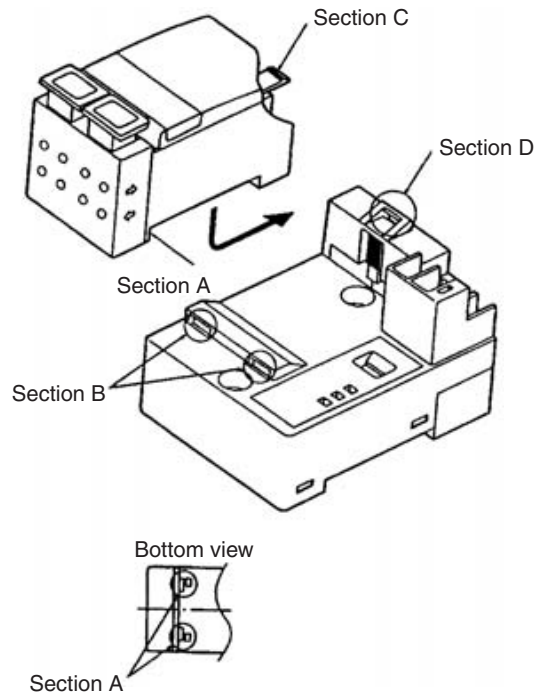

Removing Connector Unit:

- 1,2,3... 1. While pushing Section D, pull the Connector Unit in direction E.

- When Section D releases from the lock, the Connector Unit can be removed.

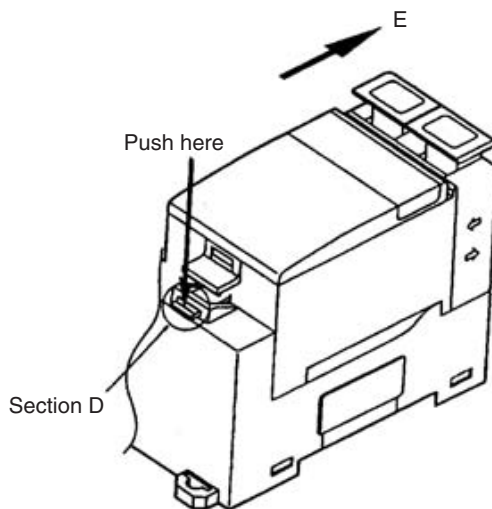

Expanding Sensor Amplifier Terminals

- 1,2,3...** 1. Remove the cover from the side of the SRT□-T□D04S. When the cover is removed, the expansion connector can be seen inside.



2. Connect this expansion connector to the connector located on the side of the SRT□-X□D04S.

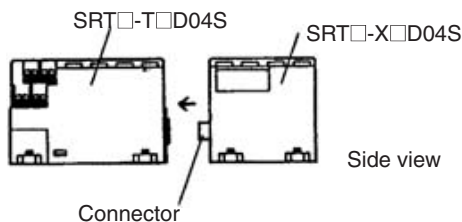

Removing Contact Connector Cover

Contacts 1 through 3 of the SRT□-TID04S are covered with a contact connector cover. When using these contacts, refer to the following figure and pull out and remove Section A of the contact connector cover in the direction of its end.

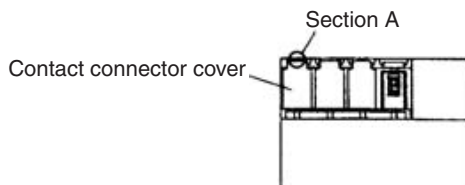

E3X-N Connectors

Nomenclature

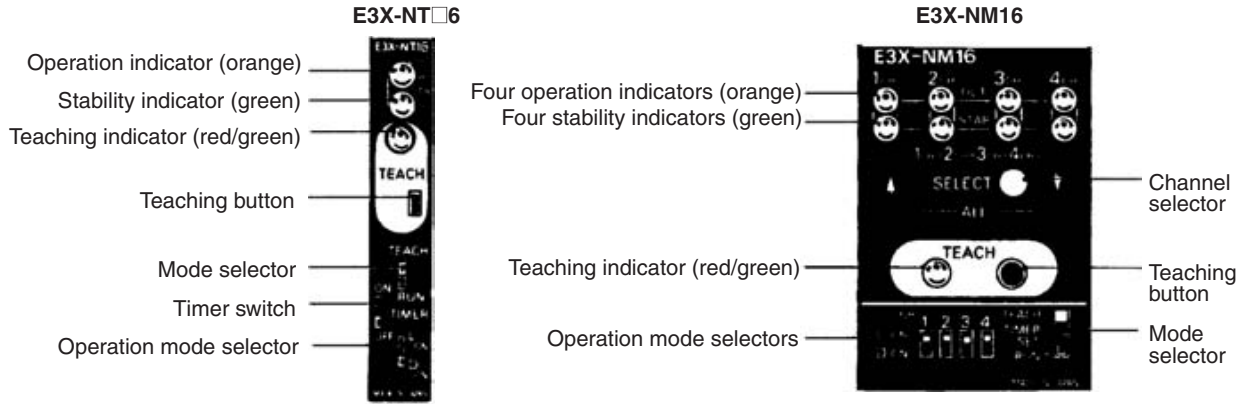

Note The E3X-NT16 does not have a timer function.

Optical Axis Adjustment (Super-flashing Function)



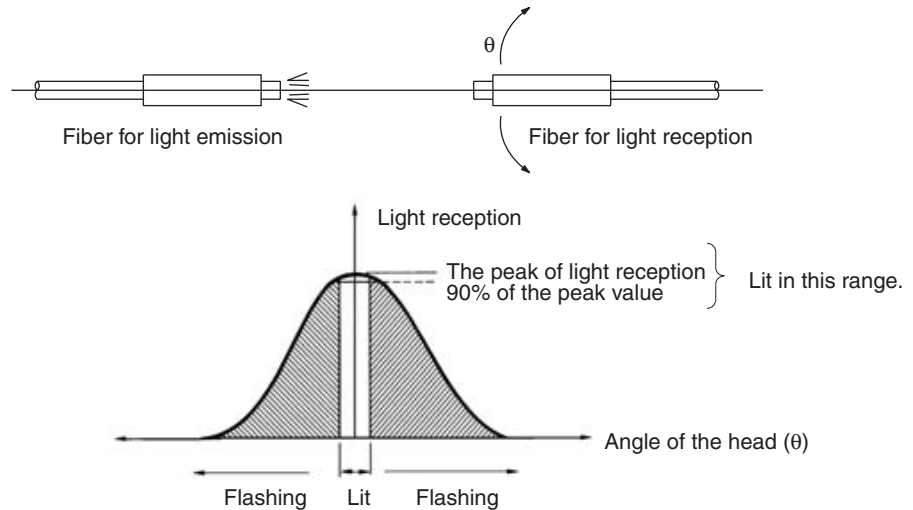

Set the mode selector of the E3X-N□ to TEACH. The super-flashing function of the E3X-N□ will be activated. When the optical axes of the fiber heads are divergent and the light value decreases by approximately 10% of the maximum value, the tip of the emitting fiber will start flashing and the built-in buzzer will beep. At this time, if the optical axes are divergent, adjust the axes. The peak light value will be memorized by the E3X-N□. Do not press the teaching button before or while adjusting the optical axes, otherwise, the super-flashing function will not operate.





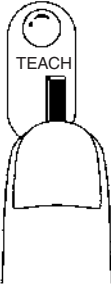
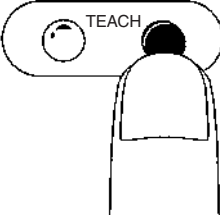



Sensitivity Settings

Maximum Sensitivity Setting

Procedure	Operation	E3X-NT	E3X-NM
1	Locate the sensor head within the rated sensing range with the E3X-N□.		
2	Set the mode selector to TEACH.		
3	The super-flashing function of the E3X-N□ will be activated. Therefore, adjust the optical axes so that the tip of the emitting fiber will be lit. If the optical axes are divergent, the tip of the emitting fiber will flash and the built-in buzzer of the E3X-N□ will beep.	---	

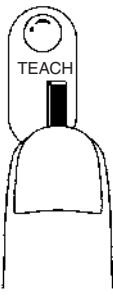
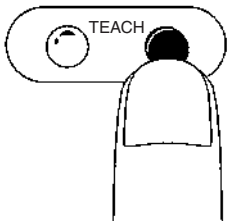

Procedure	Operation	E3X-NT	E3X-NM
4	<p>Press the teaching button for three seconds minimum with or without a sensing object. In the case of the E3X-NM, select a channel with the channel selector, at which time the stability indicator for the selected channel will flash.</p> <p>The teaching indicator (red) turns green.</p> <p>The built-in buzzer beeps once when the color of the teaching indicator is red.</p> <p>The built-in buzzer beeps continuously when the color of the teaching indicator is green.</p> <p>Note: The built-in buzzer will stop beeping when the teaching button is no longer being pressed.</p>	 <p>A vertical rectangular button with a circular indicator at the top labeled 'TEACH' and a larger, rounded rectangular area below it.</p>	 <p>A horizontal button with a circular indicator on the left labeled 'TEACH' and a larger, rounded rectangular area on the right. A vertical slider is positioned on the right side of the button.</p>
5	<p>Set the mode selector to RUN to complete the sensitivity setting.</p> <p>The teaching indicator is OFF.</p> <p>Note: When the sensitivity is set to maximum, the sensitivity will be automatically adjusted regardless of the set distances of the fibers or light.</p>	 <p>A vertical slider with 'TEACH' at the top and 'RUN' at the bottom, with a downward arrow indicating the selected position.</p>	 <p>A vertical slider with 'TEACH', 'TIMER', 'SET', and 'RUN' labels, with a downward arrow indicating the selected position.</p>
6	<p>Select the logical output required with the operation mode selector.</p>	 <p>A vertical slider with 'L ON' at the top and 'D ON' at the bottom, with a double-headed vertical arrow indicating the range of selection.</p>	 <p>A horizontal row of four sliders labeled 'CH 1', '2', '3', and '4'. Below them are labels 'L ON' and 'D ON' with a double-headed vertical arrow indicating the range of selection.</p>





No-object Teaching

Procedure	Operation	E3X-NT	E3X-NM
1	Locate the sensor head within the rated sensing range with the E3X-N□.		
2	Set the mode selector to TEACH.		
3	The super-flashing function of the E3X-N□ will be activated. Therefore, adjust the optical axes so that the tip of the emitting fiber will be lit. If the optical axes are divergent, the tip of the emitting fiber will flash and the built-in buzzer of the E3X-N□ will beep.	---	
4	Press the teaching button for 0.5 to 2.5 seconds without a sensing object. In the case of the E3X-NM, select a channel with the channel selector and press the teaching button, at which time the stability indicator for the selected channel will flash. The teaching indicator (red) is lit. The built-in buzzer beeps once.		
5	Set the mode selector to RUN. No-object teaching will be set when the first sensing object passes through the sensing area. The teaching indicator (red) turns green (automatically turned off in one second).		
6	Select the logical output required with the operation mode selector.		

- Note**
1. After no-object teaching is performed, the first to fifth incident with the corresponding sensing objects will be sampled to adjust the sensitivity.
 2. The E3X-N□ will be ready to detect objects in approximately one second after the mode selector is set to RUN.

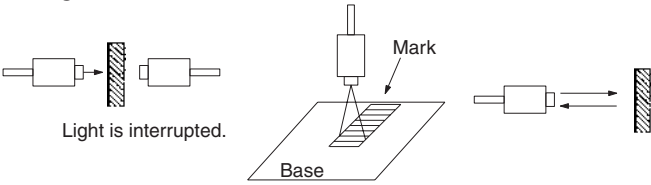
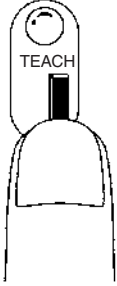
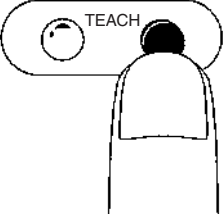
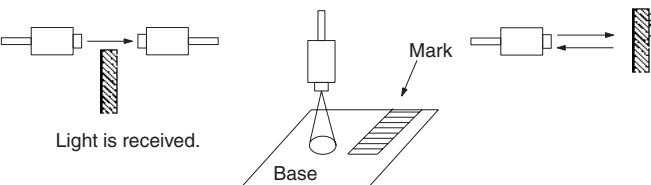
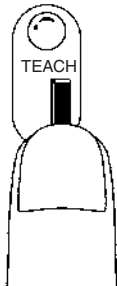
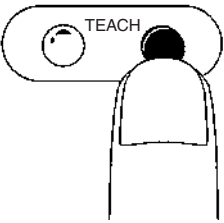
With/Without-object Teaching

Procedure	Operation	E3X-NT	E3X-NM
1	Locate the sensor head within the rated sensing range with the E3X-N□.	---	
2	Set the mode selector to TEACH.		
3	The super-flashing function of the E3X-N□ will be activated. Therefore, adjust the optical axes so that the tip of the emitting fiber will be lit. If the optical axes are divergent, the tip of the emitting fiber will flash and the built-in buzzer of the E3X-N□ will beep.	---	

Procedure	Operation	E3X-NT	E3X-NM
4	<p>Locate a sensing object in the sensing area and press the teaching button once. In the case of the E3X-NM, select a channel with the channel selector and press the teaching button, at which time the stability indicator for the selected channel will flash.</p> <p>Through-beam Model Reflective Model Reflective Model</p>  <p>Light is interrupted.</p> <p>Base</p> <p>Mark</p> <p>The teaching indicator (red) is lit. The built-in buzzer beeps once.</p>		
5	<p>Move the object and press the teaching button.</p> <p>Through-beam Model Reflective Model Reflective Model</p>  <p>Light is received.</p> <p>Base</p> <p>Mark</p> <p>If teaching is OK: The teaching indicator (red) turns green. The built-in buzzer beeps once.</p> <p>If teaching is NG: The teaching indicator (red) starts flashing. The operation indicator also starts flashing. (E3X-NM) The built-in buzzer beeps 3 times.</p> <p>Change the position of the object and the sensing distance that have been set and repeat from the beginning.</p>		
6	<p>Set the mode selector to RUN to complete the sensitivity setting.</p> <p>The teaching indicator (green) is OFF.</p>		
7	<p>Select the logical output required with the operation mode selector.</p>		

5-12 Application Precautions

5-12-1 Two-wire DC Sensor Connections

When connecting a Unit with transistor inputs to a 2-wire DC sensor, check that the following conditions are satisfied, or otherwise the Unit may malfunction.

Relationship between ON Voltage of Unit with Transistor Inputs and Residual Voltage of Sensor

$$V_{ON} \leq V_{CC} - V_R$$

V_{CC} : I/O power supply voltage (calculated at 20.4 V in consideration of the worst condition through the power supply voltage range is between 20.4 and 26.4 V.)

V_{ON} : ON voltage of Unit with transistor inputs (Refer to page 351 for specifications for each Slave.)

V_R : Output residual voltage of sensor

The above formula can be satisfied by setting the I/O power supply voltage (V_{CC}) to 26.4 V.

Relationship between ON Current of Unit with Transistor Inputs and Control Output (Load current) of Sensor

$$I_{OUT} (\text{min}) \leq I_{ON} \leq I_{OUT} (\text{max})$$

I_{OUT} : Sensor control output (Load current)

I_{ON} : ON current of Unit with transistor inputs

I_{ON} is obtained from the following formula.

$$I_{ON} = (V_{CC} - V_R - V_F) / R_{IN}$$

V_F : Residual voltage of Transistor Input (Refer to page 351 for specifications for each Slave.)

R_{IN} : Input impedance of Unit with transistor inputs (Refer to page 351 for specifications for each Slave.)

If I_{ON} is smaller than $I_{OUT} (\text{min})$, connect the bleeder resistance R obtained from the following formula.

$$R \leq (V_{CC} - V_R) / (I_{OUT} (\text{min}) - I_{ON})$$

$$\text{Power } W \geq (V_{CC} - V_R)^2 / R \times 4 \text{ (Excess gain)}$$

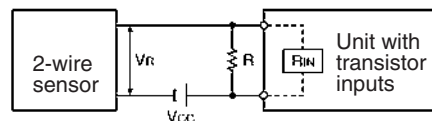

Relationship between OFF Current of Unit with Transistor Inputs and Current Leakage of Sensor

$$I_{OFF} \geq I_{leak}$$

I_{OUT} : OFF current of Unit with transistor inputs (Refer to page 351 for specifications for each Slave.)

I_{leak} : Current leakage of sensor

If I_{leak} is smaller than I_{OUT} , connect the bleeder resistance R obtained from the following formula.

$$R \leq (I_{OFF} \times R_{IN} + V_F) / (I_{leak} - I_{OFF})$$

$$\text{Power } W \geq (V_{CC} - V_R)^2 / R \times 4 \text{ (Excess gain)}$$

Specifications of each Slave

The following table shows specifications of each Slave: The ON voltage, residual voltage, input impedance, and OFF current.

Model	ON voltage (V _{ON})	Residual voltage (V _F)	Input impedance (R _{IN})	OFF current (I _{OUT})
SRT□-ID04/08/16 (-1)	15 V	2.5 V (See note.)	4.7 kΩ	1.0 mA
SRT□-ID16T/MD16T (-1)	15 V	1.5 V	4.4 kΩ	1.0 mA
SRT2-VID08S (-1)	15 V	1.5 V	4.4 kΩ	1.0 mA
SRT2-VID16ML (-1)	15 V	1.5 V	4.4 kΩ	1.0 mA
SRT2-ID32ML (-1)	15 V	1.5 V	4.4 kΩ	1.0 mA
SRT2-MD32ML (-1)	15 V	1.5 V	4.4 kΩ	1.0 mA
SRT□-ID08S	12 V	4.5 V (See note.)	2.7 kΩ	1.0 mA
SRT□-ND08S	12 V	4.5 V (See note.)	2.7 kΩ	1.0 mA
SRT2-ID04CL (-1)	15 V	1.5 V	4.4 kΩ	1.0 mA
SRT2-ID08CL (-1)	15 V	1.5 V	4.4 kΩ	1.0 mA

Note The value includes the voltage drop resulting from the LEDs and diodes.

5-12-2 Sensor Inrush Current

When the sensor ready to input is turned ON after the PLC is turned ON and the internal power supply of a Slave is turned ON, the wrong signal may be input from the sensor due to the inrush current of the sensor. Check the period between the moment the sensor is turned ON and the moment the operation of the sensor has become stable. Then program a timer delay after the sensor is turned ON.

Program example

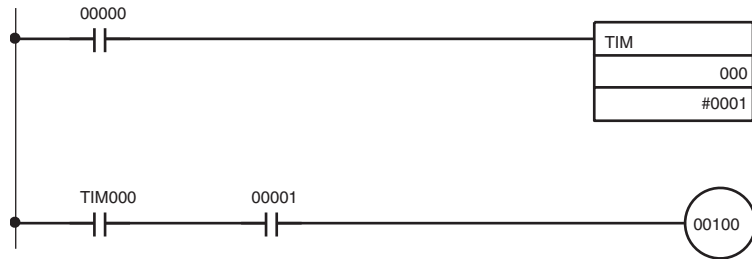

- 1,2,3...**
1. Set input bit IR 00000 to the sensor power supply voltage.
 2. Insert a timer delay for the stabilization of the sensor. The delay will be 100 ms if OMRON's Proximity Sensor is used.
 3. After the timer is ON, sensor input to input bit IR 00001 is accepted and output bit IR 00100 will be ON.

SECTION 6

Starting Communications

This section provides information on error processing, periodic maintenance operations, and troubleshooting procedures needed to keep the CompoBus/S System operating properly.

6-1	Turning the Power ON	354
6-1-1	Power-up Checklist	355
6-2	Checking Operations for CS-series, C200HX/C200HG/C200HE-(Z)E, and C200HS Master Units	356
6-2-1	Indicators	356
6-2-2	Checking Status Using Status Information	357
6-2-3	Checking Normal Operations Using Ladder Programs	359
6-2-4	Troubleshooting	360
6-3	Checking Operations of CS-series and CJ-series Master Units	365
6-3-1	Indicators	365
6-3-2	Checking Status Using Status Information	365
6-3-3	Checking Status Using Special I/O Unit DM Area	367
6-3-4	Checking Normal Operations Using Ladder Programming	371
6-3-5	Troubleshooting	373
6-4	Checking Operations of CQM1 Master Units	377
6-4-1	Indicators	377
6-4-2	Error Detection with the Alarm Output (CQM1 Only)	378
6-4-3	Checking Normal Operations Using Ladder Programming	379
6-4-4	Troubleshooting	379
6-5	Checking Slave Operations	382
6-5-1	Indicators	382
6-6	Cleaning and Inspection	384
6-6-1	Cleaning	384
6-6-2	Inspection	384
6-7	Precautions for Replacement of Units or Parts	385
6-7-1	Precautions for Unit Replacement	385
6-7-2	Settings after Unit Replacement	385
6-7-3	Replacing Relays	385

6-1 Turning the Power ON

Once all of the connections and settings have been made, power can be supplied to all of the Units in the CompoBus/S System and communications can be started.

Caution Power Connections

Be sure to check the power supply connections carefully before turning the power ON. Incorrect wiring can damage the Units in the system or cause them to malfunction.

Required Settings

The settings required for CompoBus/S I/O data communications are the Master Unit switch settings, the node number setting, and the communications mode setting on each Slave Unit. Depending on the Slaves being used, other settings such as holding or clearing outputs for communications errors may be required. Refer to *SECTION 4 Master Unit Specifications and Operations* and *SECTION 5 Slave Specifications and Operations* for details.

Before turning ON the power, check the settings and wiring, referring to *3-5 Operations Checklist*.

Turning the Power ON

The Units in a CompoBus/S System can be turned ON in any order. Turn ON the power to the Slaves first, however, to enable communications to start at the same time that the Master Unit is started up. The following table shows which Units are supplied by each power supply.

Unit	Required power supply
Master	PLC's power supply
Network power supply Slave	Communications power supply (including the I/O power supply)
Dual power supply Slave	Communications power supply and I/O power supply
Local power supply Slave	Slave power supply

CompoBus/S communications will start up automatically once the required power has been supplied to all of the Units.

- Note**
1. An error will not occur if the Slave has the same node number setting as another Unit. Use the status area in the Master Unit to detect for Slaves that have the same node number.
 2. When the Slave registration function is used with a CS-series or CJ-series Master Unit, the Slaves start to be checked after the Master has been started up and the registered Slave input monitoring time has lapsed. When Slaves are slow to power up, a verification error (Slave missing) may occur, so check the power-up timing
 3. When using a CS-series or CJ-series Master Unit, if the Slave registration function is used and the system is started up after being connected and set, incorrect node number settings and Slaves that are missing from the network can be easily checked

6-1-1 Power-up Checklist

After turning the power ON, use the following checklist to verify the CompoBus/S communications have started properly.

Unit	Check	Answer
Master	Are the RUN, SD, and RD indicators lit?	Yes No
	With CS-series, C200HX/C200HG/C200HE-(Z)E, and C200HS Master Units, is the ERC indicator OFF?	Yes No
	With CS-series Master Units, are the ERH and ERC indicators OFF?	Yes No
	With CJ-series Master Units, are the ERH and ERC indicators OFF?	Yes No
	With a CS-series, C200HX/C200HG/C200HE-(Z)E, and C200HS Master Unit, CS-series Master Unit, or CJ-series Master Unit, are the Active Node Flags ON for all of the Slaves connected to the system?	Yes No
	With CQM1 Masters, are the ERS and ERC indicators OFF?	Yes No
Slave	Are the PWR and COMM indicators lit?	Yes No
	Is the ERR indicator OFF?	Yes No
	Is the U.ERR indicator OFF? (For SRT2-AD04 and SRT2-DA02 Analog Terminals only)	Yes No

- Note**
1. If any questions are answered "No," refer to *6-2 Checking Operations for CS-series, C200HX/C200HG/C200HE-(Z)E, and C200HS Master Units* to *6-5 Checking Slave Operations* for instructions on identifying and clearing the cause of the error.
 2. For SRM1 and CPM2C-S Master Units, refer to the *SRM1 Operation Manual* and *CPM2C-S Operation Manual*.

6-2 Checking Operations for CS-series, C200HX/C200HG/C200HE-(Z)E, and C200HS Master Units

6-2-1 Indicators

Errors and Troubleshooting

Situation	Indicator status				Probable cause	Possible remedy
	RUN	ERC	SD	RD		
Normal communications	ON	OFF	ON	ON	---	---
PLC's power OFF	OFF	OFF	OFF	OFF	The PLC's power is OFF.	Turn the PLC's power supply ON.
Not connected to Backplane	OFF	OFF	OFF	OFF	The Master is not completely connected to the Backplane.	Mount the Master properly.
CPU Unit standby status	OFF	OFF	OFF	OFF	One of the Special I/O Units is faulty.	Replace the faulty Unit, which will be indicated by a "\$" in the I/O table.
Special I/O Unit error	OFF	OFF	OFF	OFF	Refreshing between the PLC and Master Unit is not being performed properly.	After correcting the cause, toggle the Unit's restart bit in the AR Area. Replace the Unit if it doesn't reset when the restart bit is toggled.
I/O UNIT OVER error	OFF	OFF	OFF	OFF	The same unit number has been set on two or more Special I/O Units. An out-of-range unit number has been set.	Set unique unit numbers. If the usable node numbers are within IN0 to IN15 and OUT0 to OUT15, 9 or F cannot be set. node numbers A to F cannot be used with C200HX-CPU3□-(Z)E/ -CPU4□-(Z)E, C200HG-CPU3□-(Z)E/ -CPU4□-(Z)E, or C200HS PLCs.
I/O BUS error	OFF	OFF	OFF	OFF	The I/O bus is not connected correctly. (In CS-series PLCs, an I/O BUS error may have occurred in another Unit.)	Check the I/O connecting cables between all Racks. Clear the error after the connection is fixed.
Slave not connected	ON	OFF	ON	OFF	No Slaves are connected, or the communications mode of each Slave does not match that of the Master Unit.	Use a Slave that can communicate properly, or make the communications mode of each Slave match that of the Master Unit.
Communications error with a Slave	ON	ON	ON	---	An error has occurred with a Slave during communications and it is withdrawn from the system.	Check the Communications Error Flags or indicators and clear the cause of the communications error. See <i>Communications Error Node Number Indicators</i> below.

Note Check the system's operation with just one Slave connected (one Slave at a time) if the CompoBus system does not operate but the Master's indicator status does not match any of those in the table.

Communications Error Node Number Indicators (C200HW-SRM21-V1 Only)

When a communications error occurs with a Slave during communications and the ERC indicator lights, the other indicators will show the node number of the Slave where the error occurred in binary.

When several communications errors occur simultaneously, the node number of the Slave with the first recognized communications error will be displayed. The display will not be changed if another communications error occurs while a node number is already being displayed. A new node number can be displayed after the first communications error is cleared.

When a communications error occurs in a 16-point or greater Slave, any of the node numbers currently used by that Slave may be displayed.

The following table shows some examples of node number displays.

Situation	Indicator status						Possible remedy
	ERC	I/O	8	4	2	1	
Communications error in the Input Slave with node number 13	ON	OFF	ON	ON	OFF	ON	Check the communications cable to Input Slave 13 and the status of the Slave itself.
Communications error in the Output Slave with node number 6	ON	ON	OFF	ON	ON	OFF	Check the communications cable to Output Slave 6 and the status of the Slave itself.
Communications error in the Input Slave with node number 0	ON	OFF	OFF	OFF	OFF	OFF	Check the communications cable to Input Slave 0 and the status of the Slave itself.
A communications error occurs in the Output Slave with node number 11 after an error occurs in the Input Slave with node number 3.	ON	OFF	OFF	OFF	ON	ON	First, check the communications cable to Input Slave 3 and the status of the Slave itself. Once the error in Input Slave 3 is cleared, the display will show the error in Output Slave 11 and this error can be cleared.

6-2-2 Checking Status Using Status Information

When using CS-series, C200HX/C200HG/C200HE-(Z)E, or C200HS Master Units, information on active Slave status and communications error status is stored for each Slave in the status area of the PLC's Special I/O Unit Area.

Status Area Location and Configuration

The location and configuration of the status area is shown in the following table.

Usable Node Number is IN0 to IN7 and OUT0 to OUT7

Two words are used for flags when the max. number of Slaves setting is 16.

PLC	Location of Status Area
CS-series PLCs	First word = $2000 + \text{unit number} \times 10$
C200HX/C200HG/ C200HE-(Z)E, and C200HS PLCs	Unit numbers 0 to 9: First word = $100 + \text{unit number} \times 10$ Unit numbers A to F (10 to 15): First word = $400 + (\text{unit number} - 10) \times 10$

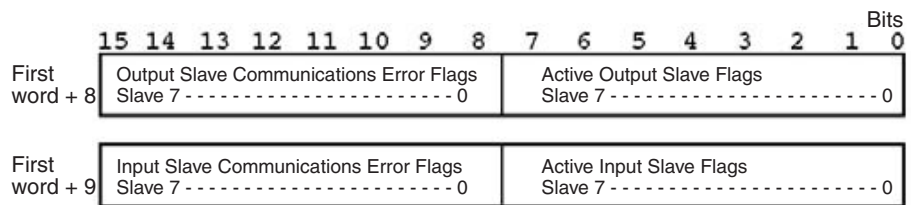

Usable Node Number is IN0 to IN15 and OUT0 to OUT15

Four words are used for flags when the max. number of Slaves setting is 32.

PLC	Location of Special I/O Unit Area
CS-series PLCs	First word = $2000 + \text{unit number} \times 10$
C200HX/C200HG/ C200HE-(Z)E, and C200HS PLCs	Unit numbers 0 to 8: First word = $100 + \text{unit number} \times 10$ Unit numbers A to E (10 to 14): First word = $400 + (\text{unit number} - 10) \times 10$

	15	14	13	12	11	10	9	8	7	6	5	4	3	2	1	0	Bits
First word + 16	Output Slave Communications Error Flags Slave 7 ----- 0								Active Output Slave Flags Slave 7 ----- 0								
First word + 17	Input Slave Communications Error Flags Slave 7 ----- 0								Active Input Slave Flags Slave 7 ----- 0								
First word + 18	Output Slave Communications Error Flags Slave 15 ----- 8								Active Output Slave Flags Slave 15 ----- 8								
First word + 19	Input Slave Communications Error Flags Slave 15 ----- 8								Active Input Slave Flags Slave 15 ----- 8								

Status Flag Functions

The status flags have the following functions. These flags are automatically cleared to 0 when the power is turned ON or the system is restarted.

Active Output Slave Flags

These flags indicate whether the corresponding Output Slaves are active nodes in the CompoBus/S communications.

Flag status	Meaning
0 (OFF)	The corresponding Slave is not participating in communications. (OFF if the Slave didn't participate even one time.)
1 (ON)	The corresponding Slave is participating in communications. (Not changed even if the Slave is withdrawn from communications.)

Active Input Slave Flags

These flags indicate whether the corresponding Input Slaves are active nodes in the CompoBus/S communications.

Flag status	Meaning
0 (OFF)	The corresponding Slave is not participating in communications. (OFF if the Slave didn't participate even one time.)
1 (ON)	The corresponding Slave is participating in communications. (Not changed even if the Slave is withdrawn from communications.)

Output Slave Communications Error Flags

These flags indicate whether a communications error has occurred with the corresponding Output Slaves.

Flag status	Meaning
0 (OFF)	Normal communications or the Slave is not participating in communications.
1 (ON)	Withdrawn from communications (communications error)

Input Slave Communications Error Flags

These flags indicate whether a communications error has occurred with the corresponding Input Slaves.

Flag status	Meaning
0 (OFF)	Normal communications or the Slave is not participating in communications.
1 (ON)	Withdrawn from communications (communications error)

Note Input from Input Slaves and output to Output Slaves are enabled when the CompoBus/S System is started up and the Active Node Flag corresponding to the Slave turns ON. During actual operation, it is recommended to create ladder programming that processes Slave I/O after checking that Active Node Flags are ON and Communications Error Flags are OFF.

6-2-3 Checking Normal Operations Using Ladder Programs

This section provides information on how to write a ladder program to monitor the operation of the CompoBus/S System and prohibit using the I/O data of the Slaves in the system when an error occurs.

To write a ladder program for CompoBus/S remote I/O communications for the CS-series, C200HX, C200HG, C200HE-(Z)E, or C200HS Master Unit, it is recommended to write I/O data on condition that the Active Node Flags and Communications Error Flags in the status area are monitored to check the operation of the CompoBus/S System.

The CompoBus/S status area has the following flags. (Refer to page 81.)

Active Node Flags:

Once a Slave joins the CompoBus/S network after the Slave is turned ON, the Active Node Flag corresponding to the Slave will be ON.

Communications Error Flags:

If a Slave in the network fails to communicate with the Master, the Communications Error Flag corresponding to the Slave will be ON. After the Communications Error Flag is ON, the previous input data from the input Slave will be kept on hold. While the Communications Error Flag is ON, the input data of the input Slave is not reliable. (The program will be executed with the previous data.)

The following ladder program example uses I/O data after checking the normal operation of the CompoBus/S System. In this example, the C200HX Master with unit number 0 is used and usable node numbers are IN0 to IN7 and OUT0 to OUT7.

Wrong

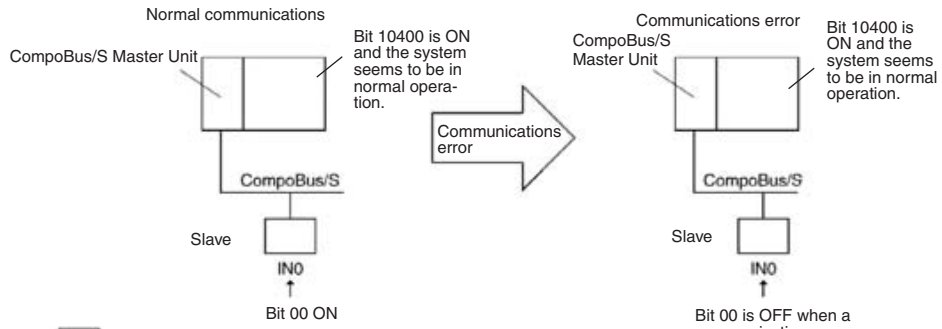
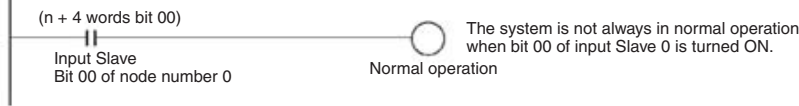

Correct

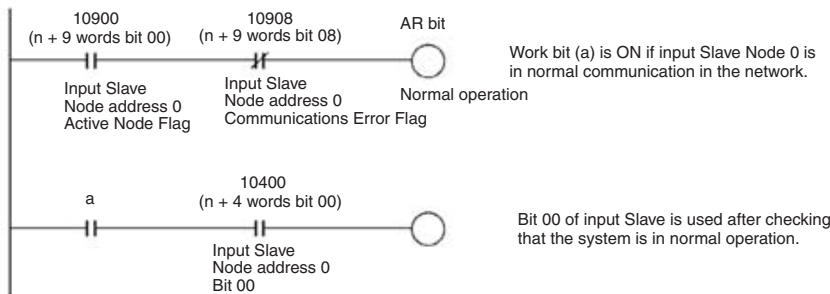

It is possible to write a ladder program that confirms normal operation when a work bit (a) turns OFF.

A ladder program that checks all the Active Node Flags and Communications Error Flags in a batch, checks the overall CompoBus/S System operations, and then performs I/O processing for the Slaves in a batch can also be written. For details, refer to the section for CJ-series Master Units under 6-3-4 *Checking Normal Operations Using Ladder Programming*.

6-2-4 Troubleshooting

When an error occurs, the indicators of a Master Unit connected to a CS-series, C2missing00HX/C200HG/C200HE-(Z)E, or C200HS PLC will indicate the error. Check the Master Unit's indicators and perform the error processing described in the following table.

When an error occurs in a Slave, the Slave can be identified from the status of the Master's indicators or from the status flags in the PLC's Special I/O Unit Area.

Error	Probable cause	Possible remedy
The Master Unit's RUN indicator is OFF	The PLC's power is OFF.	Turn the PLC's power supply ON.
	The same unit number has been set on another Special I/O Unit, causing an I/O UNIT OVER error in the PLC.	Check that the same unit number is not used by more than one Special I/O Unit and restart the PLC. In particular, when the usable node number setting is IN0 to IN15 and OUT0 to OUT15, check that the next unit number after the one set on the Master Unit is not set on another Special I/O Unit.
	The unit number has been set outside the specified range, causing an I/O UNIT OVER error in the PLC.	Check that the unit number is set within the range specified for Special I/O Units and restart the PLC. CS-series: Unit numbers 0 to F can be set when the maximum number of Slaves setting is 16 (pin 1 OFF); Mountable number of Master Units is 16 when using 10 words as a Special I/O Unit; Usable node number setting is IN0 to IN7 and OUT0 to OUT7 Unit numbers 0 to E can be set when the maximum number of Slaves setting is 32 (pin 1 ON); Mountable number of Master Units is 8 when using 20 words as a Special I/O Unit; Usable node number setting is IN0 to IN15 and OUT0 to OUT15 C200HX-CPU3□-(Z)E/-CPU4□-(Z)E, C200HX-CPU3□-(Z)E/-CPU4□-(Z)E, C200HE, and C200HS PLCs: Unit numbers 0 to 9 can be set when the maximum number of Slaves setting is 16 (pin 1 OFF); Mountable number of Master Units is 10 when using 10 words as a Special I/O Unit; Usable node number setting is IN0 to IN7 and OUT0 to OUT7 Unit numbers 0 to 8 can be set when the maximum number of Slaves setting is 32 (pin 1 ON); Mountable number of Master Units is 5 when using 20 words as a Special I/O Unit; Usable node number setting is IN0 to IN15 and OUT0 to OUT15 C200HX-CPU5□-(Z)E/-CPU6□-(Z)E/-CPU8□-(Z)E and C200HG-CPU5□-(Z)E/-CPU6□-(Z)E PLCs: Unit numbers 0 to 9 or A to F can be set when the maximum number of Slaves setting is 16 (pin 1 OFF); Mountable number of Master Units is 16 (when using 10 words as a Special I/O Unit; Usable node number setting is IN0 to IN7 and OUT0 to OUT7 Unit numbers 0 to 8 or A to E can be set when the maximum number of Slaves setting is 32 (pin 1 ON); Mountable number of Master Units is 8 (when using 20 words as a Special I/O Unit; Usable node number setting is IN0 to IN15 and OUT0 to OUT15
The Master Unit's RUN indicator is OFF	A Special I/O Unit error occurred in the PLC because the usable node number setting was changed with the PLC power ON, but just the Master Unit was restarted.	Turn the PLC OFF and then ON again.
	A Special I/O Unit error occurred in the PLC because the Master Unit is not connected securely.	Turn the PLC OFF, make sure that the Master Unit is mounted correctly, and then turn the PLC ON again. Replace the Master Unit if the error recurs.
	An input-output I/O table error occurred in the PLC because the Master Unit's unit number or usable node number setting was changed after the I/O table was registered.	Register the I/O table again.
	The Master Unit is faulty.	Replace the Master Unit.

Error	Probable cause	Possible remedy
The Master Unit's SD indicator is OFF	---	Either reset the Master Unit with the PLC's Restart Bit or turn the PLC OFF and then ON again. Replace the Master Unit if the error recurs.
The Master Unit's RD indicator is OFF	The communications cable is not connected to the Master.	Connect the communications cable correctly.
	A Slave's number has been set to 8 to 15 even though the usable node address setting is IN0 to IN7 and OUT0 to OUT7.	Either change the Input and Output Slave's node number settings so that they are 0 to 7 or change the usable node number setting to IN0 to IN15 and OUT0 to OUT15.
	One of the Slaves is not turned ON. (The Slave's PWR indicator is OFF.)	Turn ON the Slave's power supply.
	There is a problem with the Slaves' power supply.	Check the power supply cable connections and connect the cables to the Slaves correctly.
	The Slaves' power supply is inadequate.	Check the power supply capacity. If it is inadequate, either change the system configuration or change the power supply so that sufficient power is provided.
	There is a problem with the communication cable connection or the cable itself.	Check the connections and cable. Replace the communications cable if it is faulty.
	Communications modes of Master Unit and Slave do not match.	Set the communications mode so that it is the same as that of the Master Unit.
	A common system mistake has been made. (Refer to the table on page 364 for a list of common mistakes.)	Refer to the table on page 364 for common mistakes and their remedies.
	The Master Unit is faulty.	Replace the Master Unit.
The Master Unit's ERC indicator is ON	Power is not being supplied to the Slaves.	Turn ON the Slave's power supply.
	There is a problem with the Slaves' power supply.	Check the power supply cable connections and connect the cables to the Slaves correctly.
	The Slaves' power supply is inadequate.	Check the power supply capacity. If it is inadequate, either change the system configuration or change the power supply so that sufficient power is provided.
	There is a problem with the communication cable connection or the cable itself.	Check the connections and cable. Replace the communications cable if it is faulty.
	There is a non-existent node number because a Slave's node number was changed after communications were established.	Either reset the Master Unit with the PLC's Restart Bit or turn the PLC OFF and then ON again.
	The same node number is used on two Slaves.	Change the Slaves' node number settings to eliminate the duplication and then turn the Slaves ON again. Either reset the Master Unit with the PLC's Restart Bit or turn the PLC OFF and then ON again.
	A common system mistake has been made. (Refer to the table on page 364 for a list of common mistakes.)	Refer to the table on page 364 for common mistakes and their remedies.
	A Slave Unit is faulty.	Replace the faulty Slave Unit.

Error	Probable cause	Possible remedy
A Slave Unit's COMM indicator is OFF or its ERR indicator is ON	An error has occurred at the Master Unit.	Check the Master Unit's indicators and follow the procedures listed above.
	The Slave cannot participate in communications because its power supply is OFF. (The Slave's PWR indicator is OFF.)	Turn ON the Slave's power supply.
	The Slave cannot participate in communications because there is a problem with the Slaves' power supply.	Check the power supply cable connections and connect the cables to the Slaves correctly.
	The Slave cannot participate in communications because its power supply is inadequate.	Check the power supply capacity. If it is inadequate, either change the system configuration or change the power supply so that sufficient power is provided.
	The Slave cannot participate in communications because there is a problem with the communication cable connection or the cable itself.	Check the connections and cable. Replace the communications cable if it is faulty.
	The same node number is used on another Slave.	Change one of the Slave's node number settings to eliminate the duplication and then turn the Slaves ON again. Either reset the Master Unit with the PLC's Restart Bit or turn the PLC OFF and then ON again.
	A Slave's number has been set to 8 to 15 even though the usable node number setting is IN0 to IN7 and OUT0 to OUT7.	Either change the Input and Output Slave's node number settings so that they are 0 to 7 or change the usable node number setting to IN0 to IN15 and OUT0 to OUT15.
	Communications modes of Master Unit and Slave do not match.	Set the communications mode so that it is the same as that of the Master Unit.
	A common system mistake has been made. (Refer to the table on page 364 for a list of common mistakes.)	Refer to the table on page 364 for common mistakes and their remedies.
	The Slave Unit is faulty.	Replace the Slave Unit.
	The area used by the Analog Terminal or 32-point Connector Terminal exceeds the range of the Master Unit I/O Area.	Change to node numbers that do not exceed the I/O Area range, then turn ON the PLC again.
The indicators on the Master and Slaves are normal, but there are errors in the communications data	The same node number is set on two or more Input Slaves or Output Slaves.	Check the Active Node Flags for the Master and see whether the flags are ON for all of the connected Slaves. If two Slaves have the same node number, change the Slaves' node number settings.
	The PLC's Output OFF Bit is ON, so the Output Slave outputs are always OFF.	Turn OFF the PLC's Output OFF Bit.
	The communications power supply to the Slaves is ON, but the I/O power supply is OFF, so the Output Slave outputs and Input Slave inputs are always OFF.	Provide an I/O power supply to the Slaves.
	There is a problem with the communication cable connection or the cable itself.	Check the connections and cable. Replace the communications cable if it is faulty.
	Usable node numbers setting is incorrect.	Refer to 4-1-3 I/O Allocations in CS-series, C200HX/C200HG/C200HE-(Z)E, and C200HS PLCs and reset the usable node numbers to correct values.
	The Analog Terminal is connected to a C200HW-SRM21 (without V1).	Change the Master Unit to a C200HW-SRM21-V1.
	A common system mistake has been made. (Refer to the table on page 364 for a list of common mistakes.)	Refer to the table on page 364 for common mistakes and their remedies.
	The Master or a Slave Unit is faulty.	Replace the Slave Unit. Replace the Master Unit if the problem recurs.

Common Mistakes

The following table shows common connection mistakes and their remedies.

Mistake	Remedy
A terminator is not connected.	Connect a terminator (connector or terminal-block) at the end of the cable farthest from the Master.
The terminator is not connected at the end of the cable farthest from the Master.	Connect the terminator at the end of the cable farthest from the Master.
The master is not connected at one end of the main line in a system in which the main line must be distinguished from the branch lines.	Connect the Master at one end of the main line.
The length of the main line, a branch line, or the total length of the branch lines of the system in which the main line must be distinguished from the branch lines is not within specifications.	Make sure that the lengths of the cables in the system are within the specifications listed in <i>2-2-2 Maximum Cable Length</i> , or change the communications mode to Long-distance Communications Mode so that the length of the cables in the system will be within specifications.
The total communications cable in the system in which the main line does not need to be distinguished from the branch lines is not within specifications.	Refer to <i>2-2-2 Maximum Cable Length</i> and change the configuration so that the length of the total communications cable length will be within specifications.
2-conductor VCTF cable, 4-conductor VCTF cable, and Special Flat Cable are used together in the same system.	Use just one kind of cable in the system.
There is a break in the communications cable.	Reconnect or replace the communications cable.
When 4-conductor VCTF cable or Special Flat Cable is being used, a connector is not attached securely to the cable.	Make sure that the connectors are crimped correctly on the cable.
A connector is faulty.	Replace the faulty connector.

6-3 Checking Operations of CS-series and CJ-series Master Units

6-3-1 Indicators

Errors and Troubleshooting

Situation	Indicator status					Probable cause	Possible remedy
	RUN	ERH	ERC	SD	RD		
Normal communications	ON	OFF	OFF	ON	ON	---	---
PLC's power OFF	OFF	OFF	OFF	OFF	OFF	The PLC's power is OFF.	Turn the PLC's power supply ON.
						The correct voltage is not being supplied to the PLC.	Supply the correct voltage to the PLC.
						The Master Unit is faulty.	Replace the Master Unit.
						The PLC is faulty.	Replace the PLC (CPU Unit, Power Supply Unit).
Unit number setting error	OFF	ON	OFF	OFF	OFF	The same unit number is set on another Special I/O Unit, or the unit number is not within the specified range for Special I/O Units.	Set unit numbers that are unique and within the specified range.
						The Master Unit was restarted after changing the usable node number setting switch (DIP switch pin 1).	Restart the PLC and set to automatically create I/O tables.
						The CPU Unit is faulty.	Restart the PLC. If the same error occurs, replace the CPU Unit.
Master Unit error	OFF	OFF	ON	OFF	OFF	The Master Unit is faulty.	Replace the Master Unit.
CPU Unit error	---	ON	---	---	---	An error has occurred in the CPU Unit.	Remove the cause of the error, and restart the PLC. If the same error occurs, replace the CPU Unit.
Communications error	ON	---	ON	---	---	A Slave disconnection has been detected.	Remove the cause of the error. In communications stop mode, turn ON the power or restart the Unit after removing the cause of the error. In normal communications mode, the Unit will restart automatically.
						The Master Unit is faulty.	Restart the Master Unit. If the same error occurs, replace the Master Unit.
Verification error	ON	---	ON	ON	---	When the Slave registration function is used indicates detection of a Slave that is missing in the network or an unregistered Slave that is in the network.	When a Slave is missing, the Unit will restart automatically when the missing Slave is connected to the network. When an unregistered Slave is detected, restart the Master Unit after removing the unregistered Slave.

Note Check the system's operation with just one Slave connected (one Slave at a time) if the CompoBus system does not operate but the Master's indicator status does not match any of those in the table.

6-3-2 Checking Status Using Status Information

When using a CS-series or CJ-series Master Unit, information on active Slave status and communications error status is stored for each Slave in the status area of the PLC's Special I/O Unit Area.

This status can be read out using a Programming Device (such as the CX-Programmer) to monitor Slave status.

Status Area Location and Configuration

The location and configuration of the status area is shown in the following table.

PLC	Location of Status Area
CS-series and CJ-series PLCs	First word = 2000 + unit number × 10

Usable Node Number is IN0 to IN7 and OUT0 to OUT7

	15	14	13	12	11	10	9	8	7	6	5	4	3	2	1	0	Bits
First word	Output Slave Communications Error Flags Slave 7								Active Output Slave Flags Slave 7								0
+ 8	-----								-----								0
First word	Input Slave Communications Error Flags Slave 7								Active Input Slave Flags Slave 7								0
+ 9	-----								-----								0

Usable Node Number is IN0 to IN15 and OUT0 to OUT15

	15	14	13	12	11	10	9	8	7	6	5	4	3	2	1	0	Bits
First word	Output Slave Communications Error Flags Slave 7								Active Output Slave Flags Slave 7								0
+ 16	-----								-----								0
First word	Input Slave Communications Error Flags Slave 7								Active Input Slave Flags Slave 7								0
+ 17	-----								-----								0
First word	Output Slave Communications Error Flags Slave 15								Active Output Slave Flags Slave 15								8
+ 18	-----								-----								8
First word	Input Slave Communications Error Flags Slave 15								Active Input Slave Flags Slave 15								8
+ 19	-----								-----								8

Status Flag Functions

The status flags have the following functions. These flags are automatically cleared to 0 when the power is turned ON or the system is restarted.

Active Output Slave Flags

These flags indicate whether the corresponding Output Slaves are active nodes in the CompoBus/S communications.

Flag status	Meaning
0 (OFF)	The corresponding Slave is not participating in communications. (OFF if the Slave didn't participate even one time.)
1 (ON)	The corresponding Slave is participating in communications. (Not changed even if the Slave is withdrawn from communications.)

Active Input Slave Flags

These flags indicate whether the corresponding Input Slaves are active nodes in the CompoBus/S communications.

Flag status	Meaning
0 (OFF)	The corresponding Slave is not participating in communications. (OFF if the Slave didn't participate even one time.)
1 (ON)	The corresponding Slave is participating in communications. (Not changed even if the Slave is withdrawn from communications.)

Output Slave Communications Error Flags

These flags indicate whether a communications error has occurred with the corresponding Output Slaves.

Flag status	Meaning
0 (OFF)	Normal communications or the Slave is not participating in communications.
1 (ON)	Withdrawn from communications (communications error) (This flag turns OFF automatically when the Slave rejoins communications.)

Input Slave Communications Error Flags

These flags indicate whether a communications error has occurred with the corresponding Input Slaves.

Flag status	Meaning
0 (OFF)	Normal communications or the Slave is not participating in communications.
1 (ON)	Withdrawn from communications (communications error) (This flag turns OFF automatically when the Slave rejoins communications.)

- Note**
1. Input from Input Slaves and output to Output Slaves is enabled when the CompoBus/S System is started up and the Active Node Flag corresponding to the Slave is turned ON. During actual operation, it is recommended to create a ladder program that processes Slave I/O after checking that Active Node Flags are turned ON and Communications Error Flags are OFF.
 2. When a CS-series or CJ-series Master Unit is set to communications stop mode, communications will stop when the Output Slave Communications Error Flag or Input Slave Communications Error Flag turns ON.

6-3-3 Checking Status Using Special I/O Unit DM Area

A CS-series and CJ-series Master Unit is allocated an area in the PLC's Special I/O Unit DM Area for setting and information storage for the Slave registration function and communications stop mode. Use a Programming Device (such as the CX-Programmer) to read the area and check the communications status and which Slave the error occurred in.

Master Unit's DM Area Words and Configuration

The following table shows the location and configuration of the Special I/O Unit DM Area words used by a CS-series and CJ-series Master Unit.

PLC	Location of Status Area
CS-series and CJ-series PLCs	First word = D20000 + unit number × 100

First word = D20000 + (unit number × 100)

	15	14	13	12	11	10	9	8	7	6	5	4	3	2	1	0	Bits
First word	Output Slave Registration Table (Used only when Slave registration function is enabled.)																CPU Unit-to-Master Unit (The contents of this area is transferred to the Master Unit from the CPU Unit when the power is turned ON. When the contents has changed, turn ON the power again.)
First word + 1	Input Slave Registration Table (Used only when Slave registration function is enabled.)																
First word + 2	Registered Slave Participation Monitoring Time (Used only when Slave registration function is enabled.)																
First word + 3	Reserved for system use. (Cannot be used.)																
First word + 4	Status Flags (Used when Slave registration or communications stop mode are enabled.)																Master Unit-to-CPU Unit
First word + 5	Communications Stopped Node Number and Slave Type (Used only when communications stop mode is enabled.)																
First word + 6	Output Slave Verification Error: Slave Missing (Used only when Slave registration function is enabled.)																
First word + 7	Input Slave Verification Error: Slave Missing (Used only when Slave registration function is enabled.)																
First word + 8	Output Slave Verification Error: Unregistered Slave in Network (Used only when Slave registration function is enabled.)																
First word + 9	Input Slave Verification Error: Unregistered Slave in Network (Used only when Slave registration function is enabled.)																
First word + 10 to First word + 99	Not used. (Can be used as work bits/words.)																

The contents from the first word to the first word +9 cannot be used for any other purpose. These words can be used, however, if the Slave registration function and communications stop mode are not enabled.

Checking Operations Using DM Area Words

The following table shows the functions of the words in the Master Unit's Special I/O Unit DM Area that are used to check operations.

For details on the words used to set the Slave registration function, refer to 4-3-5 Slave Registration Function and Communications Stop Mode.

Word	Bit	Name	Function
+4	00	Registration Completed Flag	This flag is turned ON when all registered Slaves have joined the network. If all the registered Slaves have joined the network within the registered Slave participation monitoring time this flag will turn ON even if unregistered Slaves have also joined. The flag will not turn ON, however, if there are no Slaves set in the Slave registration table. The flag will remain ON until the power is turned OFF and ON again or the Unit is restarted.
	08	Verification Error Flag: Slave Missing	This flag is turned ON under the following conditions. Registered Slaves do not join the network within the registered Slave participation monitoring time. When the Slave that caused the verification error is joined in the network, the flag will automatically be turned OFF. Check which Slave caused the error in the bit for verification error (Slave missing) in Output Slave (first word + 6) or verification error (Slave missing) in Input Slave (first word + 7).
	09	Verification Error Flag: Unregistered Slave in Network	This flag is turned ON when an unregistered Slave has joined the network. The flag will remain ON until the power is turned OFF and ON again or the Unit is restarted, even if the Slave that caused the verification error is removed from the network. Check which Slave caused the error in the bit for Output Slave verification error (unregistered Slave in network) (first word + 8) or Input Slave verification error (unregistered Slave in network) (first word + 9).
	10	Communications Stopped Flag	This flag is turned ON when the Master Unit is set to communications stop mode and remote I/O communications stop due to a communications error,. Once the flag has turned ON, the status remains until the power is turned OFF and ON again or the Unit is restarted. Check which Slave caused the error in the bits for communications stopped node number (bits 00 to 07 of first word + 5) and communications stopped Slave type (bit 15 of first word + 5).
	15	Error Flag	This flag is turned ON when any of the bits 08 to 10 are set to 1(ON). The flag is automatically turned OFF when all the bits 08 to 10 are turned OFF.
+5	00 to 07	Communications Stopped Node Number	When the Master Unit is set to communications stop mode and remote I/O communications stop due to a communications error, the node number of the Slave that caused the error is stored as a 2-digit hexadecimal (00 to 0F: 1 to 15). Check the Slave type (Output or Input) in the word for communications stopped Slave type (bit 15 of first word + 5). The node address stored will be held until the power is turned OFF and ON again or the Unit is restarted.
	15	Communications Stopped Slave Type	When the Master Unit is set to communications stop mode and remote I/O communications stop due to a communications error, the Slave type of the Slave that caused the error is stored as follows: 0 (OFF): Output Slave 1 (ON): Input Slave Check which Slave caused the error in the bits for communications stopped node number (bits 00 to 07 of first word + 5) When communications have stopped, the bit status is held until the power is turned OFF and ON again or the Unit is restarted.

Word	Bit	Name	Function		
+6	00	Output Slave Verification Error: Slave Missing	OUT0	When the Slave registration function is enabled, the bit corresponding to the node number of the Output Slave that caused the verification error (Slave missing) will be turned ON. Bits 00 to 15 correspond to Output Slave node numbers 1 to 15. When the Slave that caused the verification error joins the network, the bit will automatically turned OFF.	The bits in the Special I/O Unit Area correspond to the node numbers actually used by the Slaves. Therefore, for Slaves with 16 points or higher, the bits other than those set for the node number may also be turned ON. For example, the two consecutive bits used by a 16-point Slave or the four consecutive bits used by a 32-point Slave may be turned ON at the same time.
	01		OUT1		
	02		OUT2		
	to		to		
	13		OUT13		
	14		OUT14		
	15		OUT15		
+7	00	Input Slave Verification Error: Slave Missing	IN0	When the Slave registration function is enabled, the bit corresponding to the node number of the Input Slave that caused the verification error (Slave missing) will be turned ON. Bits 00 to 15 correspond to Input Slave node numbers 1 to 15. When the Slave that caused the verification error joins the network, the bit will automatically turned OFF.	
	01		IN1		
	02		IN2		
	to		to		
	13		IN13		
	14		IN14		
	15		IN15		
+8	00	Output Slave Verification Error: Unregistered Slave in Network	OUT0	When the Slave registration function is enabled, the bit corresponding to the node number of the Output Slave where a verification error (unregistered Slave in network) will be turned ON. Bits 00 to 15 correspond to Output Slave node numbers 1 to 15. Once a bit has been turned ON the status will be held until the power is turned OFF and ON again or the Unit is restarted.	
	01		OUT1		
	02		OUT2		
	to		to		
	13		OUT13		
	14		OUT14		
	15		OUT15		
+9	00	Input Slave Verification Error: Unregistered Slave in Network	IN0	When the Slave registration function is enabled, the bit corresponding to the node number of the Input Slave where a verification error (unregistered Slave in network) will be turned ON. Bits 00 to 15 correspond to Input Slave node numbers 1 to 15. Once a bit has been turned ON the status will be held until the power is turned OFF and ON again or the Unit is restarted.	
	01		IN1		
	02		IN2		
	to		to		
	13		IN13		
	14		IN14		
	15		IN15		

6-3-4 Checking Normal Operations Using Ladder Programming

This section provides information on how to write a ladder program to monitor the operation of the CompoBus/S System and prohibit using the I/O data of the Slaves in the system when an error occurs or the Slaves are not participating in the network correctly.

Master Unit Settings

The following table shows the Master Unit settings used in the programming example (when all Slaves OUT0 to OUT15 and IN0 to IN15 are connected).

Master's unit number	0
Usable node numbers	IN0 to IN15 and OUT0 to OUT15

Example 1

Communications will be performed only when the Communications Error Flags of all Slaves are OFF, and the Active Node Flags correspond to the configuration of connected Slaves.

Status Area

(Refer to *Status Flag Functions* on page 97 and page 119 for details.)

	15	14	13	12	11	10	9	8	7	6	5	4	3	2	1	0	Bits
CIO 2016	Output Slave Communications Error Flags Slave 7 ----- 0								Active Output Slave Flags Slave 7 ----- 0								
CIO 2017	Input Slave Communications Error Flags Slave 7 ----- 0								Active Input Slave Flags Slave 7 ----- 0								
CIO 2018	Output Slave Communications Error Flags Slave 15 ----- 8								Active Output Slave Flags Slave 15 ----- 8								
CIO 2019	Input Slave Communications Error Flags Slave 15 ----- 8								Active Input Slave Flags Slave 15 ----- 8								

Active Node Flags:

Once a Slave joins the CompoBus/S network after the Slave is turned ON, the Active Node Flag corresponding to the Slave will be ON.

Communications Error Flags:

If a Slave in the network fails to communicate with the Master, the Communications Error Flag corresponding to the Slave will be ON. After the Communications Error Flag is ON, the previous input data from the input Slave will be kept on hold. While the Communications Error Flag is ON, the input data of the input Slave is not reliable. (The program will be executed with the previous data.)

Operations

The input conditions require the Input Slave and Output Slave Active Node Flags to match the network configuration and that the Output Slave or Input Slave Communications Error Flags are OFF.

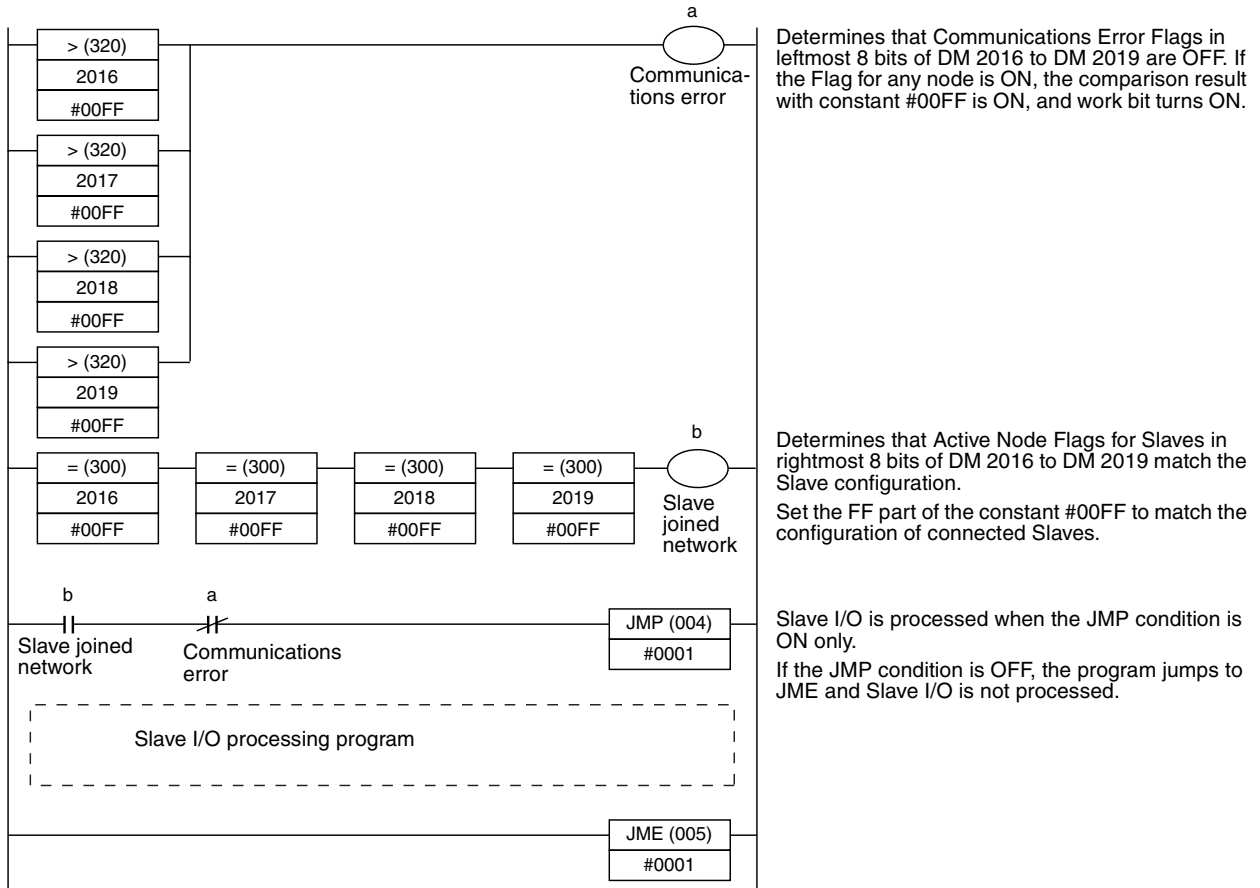

Example 2

The input conditions can be set according to the following table when the Slave registration table and communications stop mode are used (DIP switch pins 3 and 4 both set to ON).

DM Area Contents

(Refer to *Slave Registration Function and Communications Stop Mode* on page 98 and page 120 for details.)

DM address	Bit	Name	Function
D20004	00	Registration Completed Flag	ON when all registered Slaves have joined network.
	08	Verification Error Flag: Slave Missing	ON when a Slave are not present in network.
	09	Verification Error Flag: Unregistered Slave in Network	ON when an unregistered Slave is in the network.
	10	Communications Stopped Flag	ON when communications have stopped due to a communications error.
	15	Error Flag	ON when any of the flags 08 to 10 are ON.

Operations

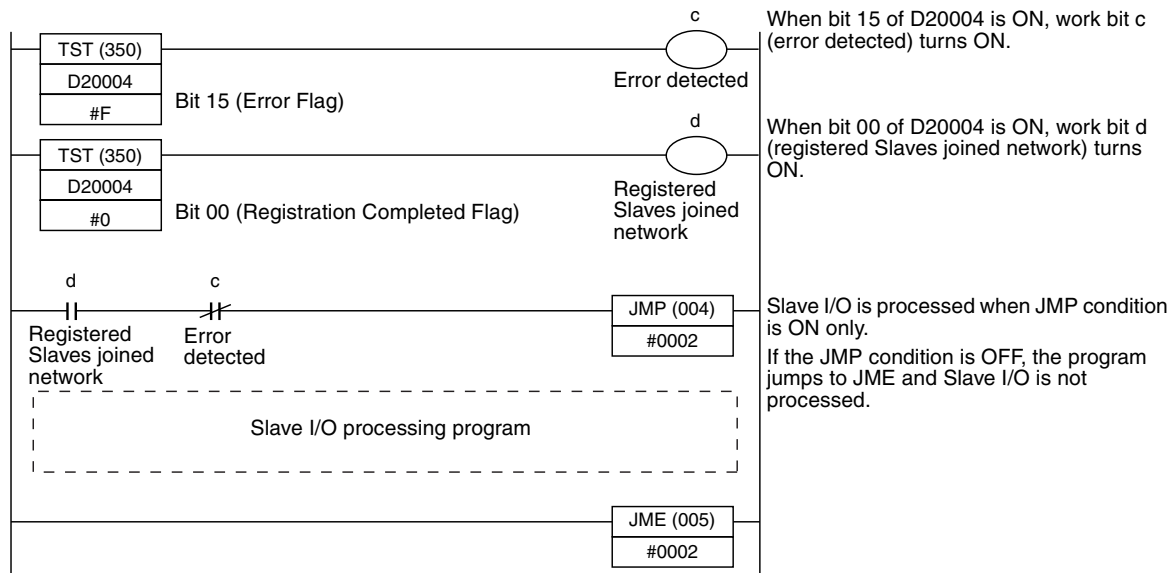

6-3-5 Troubleshooting

When an error occurs, the indicators of the Master Unit connected to a CS-series or CJ-series PLC will indicate the error. Check the Master Unit's indicators and perform the error processing described in the following table.

When an error occurs in a Slave, the Slave can be identified from the status of the Master's indicators (refer to page 76) or from the status flags (refer to page 365) in the PLC's Special I/O Unit Area.

Error	Probable cause	Possible remedy
The Master Unit's RUN indicator is OFF	The PLC's power is OFF.	Turn the PLC's power supply ON.
	The same unit number has been set on another Special I/O Unit, causing an area overlap error in the PLC.	Check that the same unit number is not used by more than one Special I/O Unit and restart the PLC. In particular, when the usable node number setting is IN0 to IN15 and OUT0 to OUT15, check that the next unit number after the one set on the Master Unit is not set on another Special I/O Unit.
	The unit number has been set outside the specified range, causing an area overlap error in the PLC.	Check that the unit number is set within the range specified for Special I/O Units and restart the PLC. CS-series and CJ-series PLCs Unit numbers 0 to 95 can be set when the Master Unit is using 10 words as a single Special I/O Unit and the usable node number setting is IN0 to IN7 and OUT0 to OUT7 (DIP switch pin 1 OFF). Unit numbers 0 to 94 can be set when the Master Unit is using 20 words as two Special I/O Units and the usable node number setting is IN0 to IN15 and OUT0 to OUT15 (DIP switch pin 1 ON).
	The usable node number setting was changed with the PLC power ON, and the Master Unit was restarted only.	Turn the PLC OFF and then ON again, and recreate the I/O tables.
	A Special I/O Unit error occurred in the PLC because the Master Unit is not connected securely.	Turn the PLC OFF, make sure that the Master Unit is mounted correctly, and then turn the PLC ON again. Replace the Master Unit if the error recurs.
	The Master Unit is faulty.	Replace the Master Unit.
	Communications stop mode is set.	Communications stop when a communications error occurs in communications stop mode. Remove the cause of the error, and then reset the Master Unit using the PLC's Restart Bit or turn the PLC OFF and then ON again.

Error	Probable cause	Possible remedy
The Master Unit's SD indicator is OFF (when communications stop mode is not enabled)	---	Either reset the Master Unit with the PLC's Restart Bit or turn the PLC OFF and then ON again. Replace the Master Unit if the error recurs.
The Master Unit's RD indicator is OFF	The communications cable is not connected to the Master.	Connect the communications cable correctly.
	A Slave's number has been set to 8 to 15 even though the usable node address setting is IN0 to IN7 and OUT0 to OUT7.	Either change the Input and Output Slave's node number settings so that they are 0 to 7 or change the usable node number setting to IN0 to IN15 and OUT0 to OUT15.
	One of the Slaves is not turned ON. (The Slave's PWR indicator is OFF.)	Turn ON the Slave's power supply.
	There is a problem with the Slaves' power supply.	Check the power supply cable connections and connect the cables to the Slaves correctly.
	The Slaves' power supply is inadequate.	Check the power supply capacity. If it is inadequate, either change the system configuration or change the power supply so that sufficient power is provided.
	There is a problem with the communication cable connection or the cable itself.	Check the connections and cable. Replace the communications cable if it is faulty.
	Communications modes of Master Unit and Slave do not match.	Set the communications mode so that it is the same as that of the Master Unit.
	A common system mistake has been made. (Refer to the table on page 364 for a list of common mistakes.)	Refer to the table on page 364 for common mistakes and their remedies.
	The Master Unit is faulty.	Replace the Master Unit.
The Master Unit's ERC indicator is ON	Power is not being supplied to the Slaves.	Turn ON the Slave's power supply.
	There is a problem with the Slaves' power supply.	Check the power supply cable connections and connect the cables to the Slaves correctly.
	The Slaves' power supply is inadequate.	Check the power supply capacity. If it is inadequate, either change the system configuration or change the power supply so that sufficient power is provided.
	There is a problem with the communication cable connection or the cable itself.	Check the connections and cable. Replace the communications cable if it is faulty.
	There is a non-existent node number because a Slave's node number was changed after communications were established.	Either reset the Master Unit with the PLC's Restart Bit or turn the PLC OFF and then ON again.
	The same node number is used on two Slaves.	Change the Slaves' node number settings to eliminate the duplication and then turn the Slaves ON again. Either reset the Master Unit with the PLC's Restart Bit or turn the PLC OFF and then ON again.
	A registered Slave has not joined the network (when Slave registration function is enabled).	Check the Slave registration table and the node number setting for each Slave.
	An unregistered Slave is in the network (when Slave registration function is enabled).	
	A common system error has occurred. (Refer to the table on page 364 for a list of common errors.)	Refer to the table on page 364 for common errors and their remedies.
	The Master Unit is faulty.	Replace the Master Unit.
	A Slave Unit is faulty.	Replace the faulty Slave Unit.

Error	Probable cause	Possible remedy
The Master Unit's ERH indicator is ON	The I/O table is not registered.	Recreate the I/O tables.
	The same unit number has been set on another Special I/O Unit.	Check that the same unit number is not used by more than one Special I/O Unit and turn the PLC OFF and ON again. In particular, when the usable node number setting is IN0 to IN15 and OUT0 to OUT15, check that the next unit number after the one set on the Master Unit is not set on another Special I/O Unit.
	The unit number has been set outside the specified range.	Check that the unit number is set within the range specified for Special I/O Units and turn the PLC OFF and ON again. CS-series and CJ-series PLCs Unit numbers 0 to 95 can be set when the Master Unit is using 10 words as a single Special I/O Unit and the usable node number setting is IN0 to IN7 and OUT0 to OUT7 (DIP switch pin 1 OFF). Unit numbers 0 to 94 can be set when the Master Unit is using 20 words as two Special I/O Units and the usable node number setting is IN0 to IN15 and OUT0 to OUT15 (DIP switch pin 1 ON).
	The CPU Unit is faulty.	Replace the CPU Unit.
A Slave Unit's COMM indicator is OFF or its ERR indicator is ON	An error has occurred at the Master Unit.	Check the Master Unit's indicators and follow the procedures listed above.
	The Slave cannot participate in communications because its power supply is OFF. (The Slave's PWR indicator is OFF.)	Turn ON the Slave's power supply.
	The Slave cannot participate in communications because there is a problem with the Slaves' power supply.	Check the power supply cable connections and connect the cables to the Slaves correctly.
	The Slave cannot participate in communications because its power supply is inadequate.	Check the power supply capacity. If it is inadequate, either change the system configuration or change the power supply so that sufficient power is provided.
	The Slave cannot participate in communications because there is a problem with the communication cable connection or the cable itself.	Check the connections and cable. Replace the communications cable if it is faulty.
	The same node number is used on another Slave between inputs Slaves or between output Slaves.	Change one of the Slave's node number settings to eliminate the duplication and then turn the Slaves ON again. Either reset the Master Unit with the PLC's Restart Bit or turn the PLC OFF and then ON again.
	A Slave's number has been set to 8 to 15 even though the usable node number setting is IN0 to IN7 and OUT0 to OUT7.	Either change the Input and Output Slave's node number settings so that they are 0 to 7 or change the usable node number setting to IN0 to IN15 and OUT0 to OUT15.
	Communications modes of Master Unit and Slave do not match.	Set the communications mode so that it is the same as that of the Master Unit.
	A common system mistake has been made. (Refer to the table on page 376 for a list of common mistakes.)	Refer to the table on page 376 for common mistakes and their remedies.
	The Slave Unit is faulty.	Replace the Slave Unit.
The area used by the Analog Terminal or 32-point Connector Terminal exceeds the range of the Master Unit I/O Area.	Change to node numbers that do not exceed the I/O Area range, then turn ON the PLC again.	

Error	Probable cause	Possible remedy
The indicators on the Master and Slaves are normal, but there are errors in the communications data	The same node number is set on two or more Input Slaves or Output Slaves.	Check the Active Node Flags for the Master and see whether the flags are ON for all of the connected Slaves. If there is a duplication, change the Slaves' node number settings.
	The PLC's Output OFF Bit is ON, so the Output Slave outputs are always OFF.	Turn OFF the PLC's Output OFF Bit.
	The communications power supply to the Slaves is ON, but the I/O power supply is OFF, so the Output Slave outputs and Input Slave inputs are always OFF.	Provide an I/O power supply to the Slaves.
	There is a problem with the communication cable connection or the cable itself.	Check the connections and cable. Replace the communication cable if it is faulty.
	Usable node numbers setting is incorrect.	Refer to 4-2-3 I/O Allocations or 4-3-4 I/O Allocations and reset the usable node numbers to correct values.
	A common system mistake has been made. (Refer to the table on page 376 for a list of common mistakes.)	Refer to the table on page 376 for common mistakes and their remedies.
	The Master or a Slave Unit is faulty.	Replace the Slave Unit. Replace the Master Unit if the problem recurs.

Common Mistakes

The following table shows common connection mistakes and their remedies.

Mistake	Remedy
A terminator is not connected.	Connect a terminator (connector or terminal-block) at the end of the cable farthest from the Master.
The terminator is not connected at the end of the cable farthest from the Master.	Connect the terminator at the end of the cable farthest from the Master.
The master is not connected at one end of the main line in a system in which the main line must be distinguished from the branch lines.	Connect the Master at one end of the main line.
The length of the main line, a branch line, or the total length of the branch lines of the system in which the main line must be distinguished from the branch lines is not within specifications.	Make sure that the lengths of the cables in the system are within the specifications listed in 2-2-2 <i>Maximum Cable Length</i> , or change the communications mode to Long-distance Communications Mode so that the length of the cables in the system will be within specifications.
The total communications cable in the system in which the main line does not need to be distinguished from the branch lines is not within specifications.	Refer to 2-2-2 <i>Maximum Cable Length</i> and change the configuration so that the length of the total communications cable length will be within specifications.
2-conductor VCTF cable, 4-conductor VCTF cable, and Special Flat Cable are used together in the same system.	Use just one kind of cable in the system.
There is a break in the communications cable.	Reconnect or replace the communications cable.
When 4-conductor VCTF cable or Special Flat Cable is being used, a connector is not attached securely to the cable.	Make sure that the connectors are crimped correctly on the cable.
A connector is faulty.	Replace the faulty connector.

6-4 Checking Operations of CQM1 Master Units

6-4-1 Indicators

Error Status

The Master Unit's indicators can indicate operating errors.

Situation	Indicator status					ALM Output	Probable cause	Possible remedy
	RUN	ERC	ERS	SD	RD			
Normal communications	ON	OFF	OFF	ON	ON	OFF	---	---
PLC's power OFF	OFF	OFF	OFF	OFF	OFF	OFF	The PLC's power is OFF.	Turn the PLC's power supply ON.
I/O UNIT OVER error	OFF	OFF	OFF	OFF	OFF	OFF	The PLC's limit on I/O points was exceeded by the CompoBus/S Master Unit.	Reduce the PLC word allocation setting or remove one of the other Units.
I/O BUS error	ON/OFF	OFF	OFF	OFF	OFF	OFF	The connection between the CPU Unit and I/O bus is not correct.	Check the mounting of each I/O Unit and the End Cover. Turn the PLC ON again after correcting the cause of the error.
Slave not connected	ON	OFF	OFF	ON	OFF	OFF	No Slaves are connected, or the communications mode of each Slave does not match that of the Master Unit.	Use a Slave that can communicate properly, or make the communications mode of each Slave match that of the Master Unit.
Data area overlap	ON	---	ON	OFF	OFF	ON	When the "number of points/node number" setting is set to 4, this status indicates that the same area is allocated to more than one Slave. Communications will be stopped.	Check the area allocated to the 8-point Slave where the error occurred, eliminate the area overlap, and then restart the PLC. See <i>Communications Error Node Number Indicators</i> below.
Address over error	ON	---	Flashing	ON	ON	OFF	When the "PLC word allocation" setting is 2 or 4 words, this status indicates that an out-of-range node number from 0 to 7 has been set.	Check the indicators and set the node number to an acceptable value. See <i>Communications Error Node Number Indicators</i> below.
Communications error with a Slave	ON	ON	---	ON	---	ON	An error has occurred with a Slave during communications and it is withdrawn from the system.	Check the indicators and clear the cause of the communications error. See <i>Communications Error Node Number Indicators</i> below.

Note Check the system's operation with just one Slave connected (one Slave at a time) if the CompoBus system doesn't operate but the Master's indicator status doesn't match any of those in the following table.

Communications Error Node Number Indicators

When a communications error occurs with a Slave during communications and the ERC indicator lights or the ERS indicator lights or flashes, the other indicators will show the node number of the Slave where the error occurred in binary.

When several communications errors occur simultaneously, the node number with the highest priority error will be displayed. The priority is as follows:

- 1,2,3...**
1. Area overlap error (ERS lit)
 2. Address over error (ERS flashing)
 3. Communications error (ERC lit)

When the same error occurs in two or more Slaves, the node number of the Slave with the first recognized error will be displayed. The display will not be changed if the same error occurs in another Slave while a node number is already being displayed for that error. The new node number can be displayed after the first error is cleared.

When a communications error occurs in a 16-point Slave, either one of the node numbers used by the Slave may be displayed.

The following table shows some examples of node number displays.

Situation	Indicator status							Possible remedy
	ERC	ERS	I/O	8	4	2	1	
Area overlap in Output Slaves with node numbers 4 and 5	---	ON	ON	OFF	ON	OFF	OFF	Change the node number for Output Slave 4 or 5. Alternatively, change the "number of points/node number" setting to 8. Restart the PLC afterwards.
Address over error in the Input Slave with node number 7	---	Flashing	OFF	OFF	ON	ON	ON	Change the node number for Input Slave 7. Alternatively, change the "PLC word allocation" and "number of points/node number" settings.
Communications error in the Input Slave with node number 13	ON	OFF	OFF	ON	ON	OFF	ON	Check the communications cable to Input Slave 13 and the status of the Slave itself.
Communications error in the Output Slave with node number 6	ON	OFF	ON	OFF	ON	ON	OFF	Check the communications cable to Output Slave 6 and the status of the Slave itself.
Communications error in the Input Slave with node number 0	ON	OFF	OFF	OFF	OFF	OFF	OFF	Check the communications cable to Input Slave 0 and the status of the Slave itself.
A communications error occurs in the Output Slave with node number 11 after a communications error occurs in the Input Slave with node number 3.	ON	OFF	OFF	OFF	OFF	ON	ON	First, check the communications cable to Input Slave 3 and the status of the Slave itself. Once the error in Input Slave 3 is cleared, the display will show the error in Output Slave 11 and this error can be cleared.

6-4-2 Error Detection with the Alarm Output (CQM1 Only)

The CompoBus/S Master Unit for CQM1 PLCs is equipped with an alarm output terminal (ALM) which is shorted by an internal relay when an error occurs. The alarm output is shorted when there is an area overlap error (ERS indicator ON) or a communications error (ERC indicator ON).

The alarm output can be used to speed the response to an error by connecting the output to a warning device such as a buzzer or using the alarm output as an input to the PLC to trigger an error subroutine.

The following table shows the specifications for the alarm output terminal (ALM). Use these specifications for reference when wiring the alarm output.

Item	Specification
Maximum switching capacity	2 A (24 V DC)
Minimum switching capacity	10 mA (5 V DC)
Relay model	G6D-1A
Minimum ON time	100 ms (Outputs are ON at least 100 ms.)
Circuits configuration	

6-4-3 Checking Normal Operations Using Ladder Programming

This section provides information on how to write a ladder program to monitor the operation of the CompoBus/S System and prohibit using the I/O data of the Slaves in the system when an error occurs or the Slaves are not participating in the network correctly.

The CQM1 Master Unit does not have a status area but an alarm output terminal (ALM) instead. The alarm output terminal is short-circuited if either of the following errors occur. (Refer to page 117.)

- Area duplication error (ERS indicator is lit)
- Communications error (ERC indicator is lit)

It is recommended to write a program that enables the Input Unit to accept alarm output and the I/O data of the Slaves in the network is used only when the alarm output terminal is OFF.

6-4-4 Troubleshooting

The indicators of a Master Unit connected to a CQM1 PLC will indicate when an error has occurred. Check the Master Unit's indicators and perform the error processing described in the following table.

When an error occurs in a Slave, the Slave can be identified from the status of the Master's indicators (refer to page 128) or from the status flags in the PLC's Special I/O Unit Area.

The alarm output can also be used to determine when an error has occurred. Refer to *6-4-2 Error Detection with the Alarm Output (CQM1 Only)* for details.

Error	Probable cause	Possible remedy
The Master Unit's RUN indicator is OFF	The PLC's power is OFF.	Turn the PLC's power supply ON.
	An I/O UNIT OVER error occurred in the PLC.	Either change the PLC word allocation setting on pins 1 and 2 of the DIP switch or remove another I/O Unit.
	An I/O BUS error occurred in the PLC because the Master Unit is not connected securely.	Turn the PLC OFF, make sure that the Master Unit is mounted correctly, and then turn the PLC ON again. Replace the Master Unit if the error recurs.
	An I/O BUS error occurred in the PLC because the PLC's End Cover is not connected securely.	Turn the PLC OFF, make sure that the End Cover is mounted correctly, and then turn the PLC ON again. Replace the Master Unit if the error recurs.
	An I/O BUS error occurred in the PLC because the PLC word allocation setting (pins 1 and 2) was changed after communications were established.	Turn the PLC OFF and then ON again.
	The Master Unit is faulty.	Replace the Master Unit.
The Master Unit's SD indicator is OFF	The same area may be allocated to more than one Slave. (The Master Unit's ERS indicator will be ON at the same time.)	See the explanation under "The Master Unit's ERS indicator is ON.," below.
	The Master Unit is faulty.	Replace the Master Unit.

Error	Probable cause	Possible remedy
The Master Unit's RD indicator is OFF	The communications cable is not connected to the Master.	Connect the communications cable correctly.
	One of the Slaves is not turned ON. (The Slave's PWR indicator is OFF.)	Turn ON the Slave's power supply.
	There is a problem with the Slaves' power supply.	Check the power supply cable connections and connect the cables to the Slaves correctly.
	The Slaves' power supply is inadequate.	Check the power supply capacity. If it is inadequate, either change the system configuration or change the power supply so that sufficient power is provided.
	There is a problem with the communication cable connection or the cable itself.	Check the connections and cable. Replace the communications cable if it is faulty.
	Communications modes of Master Unit and Slave do not match.	Set the communications mode so that it is the same as that of the Master Unit.
	A common system mistake has been made. (Refer to the table on page 382 for a list of common mistakes.)	Refer to the table on page 382 for common mistakes and their remedies.
	The Master Unit or a Slave Unit is faulty.	Replace the Master Unit. Replace the Slave Units if the problem recurs.
The Master Unit's ERS indicator is ON	The same area may be allocated to more than one Slave.	Either change the Slaves' node number settings to eliminate the I/O Area overlap or change the Master Unit's "number of points/node number" setting to 8-point mode by turning pin 3 of the DIP switch OFF. Turn the PLC ON again after making the necessary changes.
	The PLC's data area has been exceeded.	Either change the node number setting of the Slave that exceeded the PLC's I/O Area or change the Master Unit's "number of points/node number" setting to 8-point mode by turning pin 3 of the DIP switch OFF. Turn the PLC ON again after making the necessary changes.
	A 16-point or greater Slave has been connected even though the Master Unit's number of points/node number setting is 4-point mode. (Pin 3 of the DIP switch is ON.)	Either remove the 16-point or greater Slave or change the Master Unit's number of points/node number setting to 8-point mode by turning pin 3 of the DIP switch OFF. Turn the PLC ON again after making the necessary changes.
	There is a problem with the communication cable connection or the cable itself.	Check the connections and cable. Replace the communications cable if it is faulty.
	A Slave Unit is faulty.	Replace the faulty Slave Unit.
The Master Unit's ERS indicator is flashing	The "PLC word allocation" setting is 2 or 4 words, but an out-of-range node number from 0 to 7 has been set. (An address over error occurred.)	Either remove the Slave where the error occurred or change the Master's PLC word allocation setting (pins 1 and 2) and max. number of Slaves setting (pin 3) so that the Slave's node number is acceptable. Refer to 4-4-2 Switch Settings for a table showing all of the possible DIP switch settings.
	A Slave Unit is faulty.	Replace the faulty Slave Unit.

Error	Probable cause	Possible remedy
The Master Unit's ERC indicator is ON	Power is not being supplied to the Slaves.	Turn ON the Slave's power supply.
	There is a problem with the Slaves' power supply.	Check the power supply cable connections and connect the cables to the Slaves correctly.
	The Slaves' power supply is inadequate.	Check the power supply capacity. If it is inadequate, either change the system configuration or change the power supply so that sufficient power is provided.
	There is a problem with the communication cable connection or the cable itself.	Check the connections and cable. Replace the communications cable if it is faulty.
	There is a non-existent node number because a Slave's node number was changed after communications were established.	Either reset the Master Unit with the PLC's Restart Bit or turn the PLC OFF and then ON again.
	The same node number is set on two or more Input Slaves or Output Slaves.	After changing the Slaves' node number settings to eliminate the duplication, turn the Slaves ON again and then turn the PLC ON again.
	A common system mistake has been made. (Refer to the table on page 382 for a list of common mistakes.)	Refer to the table on page 382 for common mistakes and their remedies.
	A Slave Unit is faulty.	Replace the faulty Slave Unit.
A Slave Unit's COMM indicator is OFF or its ERR indicator is ON	An error has occurred at the Master Unit.	Check the Master Unit's indicators and follow the procedures listed above.
	The Slave cannot participate in communications because its power supply is OFF. (The Slave's PWR indicator is OFF.)	Turn ON the Slave's power supply.
	The Slave cannot participate in communications because there is a problem with the Slaves' power supply.	Check the power supply cable connections and connect the cables to the Slaves correctly.
	The Slave cannot participate in communications because its power supply is inadequate.	Check the power supply capacity. If it is inadequate, either change the system configuration or change the power supply so that sufficient power is provided.
	The Slave cannot participate in communications because there is a problem with the communication cable connection or the cable itself.	Check the connections and cable. Replace the communications cable if it is faulty.
	The node address set for the Slave is outside the setting range. When outside the setting range with the node addresses 0 to 7: ERS indicator of the Master Unit flashes When outside the setting range with the node address 8 to 15: ERS indicator of the Master Unit goes OFF	Change the node address of the Slave that caused the address over or change the Master Unit's PLC word allocation setting (pins 1 and 2) and max. number of Slaves setting (pin 3) so that the Slave's node number is acceptable. Refer to <i>4-4-2 Switch Settings</i> for a table showing all of the possible DIP switch settings.
	The same node number is set on two or more Input Slaves or Output Slaves.	Change one of the Slave's node number settings to eliminate the duplication, turn the Slave ON again, and then turn the PLC ON again.
	Communications modes of Master Unit and Slave do not match.	Set the communications mode so that it is the same as that of the Master Unit.
	A common system mistake has been made. (Refer to the table on page 382 for a list of common mistakes.)	Refer to the table on page 382 for common mistakes and their remedies.
	The Slave Unit is faulty.	Replace the Slave Unit.

Error	Probable cause	Possible remedy
The indicators on the Master and Slaves are normal, but there are errors in the communications data	The same node number is set on two or more Input Slaves or Output Slaves.	Change one of the Slave's node number settings to eliminate the duplication, turn the Slave ON again, and then turn the PLC ON again.
	The PLC's Output OFF Bit is ON, so the Output Slave outputs are always OFF.	Turn OFF the PLC's Output OFF Bit.
	The communications power supply to the Slaves is ON, but the I/O power supply is OFF, so the Output Slave outputs and Input Slave inputs are always OFF.	Provide an I/O power supply to the Slaves.
	There is a problem with the communication cable connection or the cable itself.	Check the connections and cable. Replace the communications cable if it is faulty.
	The setting of the number of words allocated to the PLC, or the number of points allocated to a single node number is incorrect.	Refer to 4-4-3 I/O Allocations in CQM1 PLCs and correct the number of words allocated to the PLC or the number of points allocated to a single node number.
	An Analog Terminal is connected to a CQM1-SRM21 (without V1).	Change the Master Unit to a CQM1-SRM21-V1.
	A common system mistake has occurred. (Refer to the table on page 382 for a list of common mistakes.)	Refer to the table on page 382 for common mistakes and their remedies.
	The Master or a Slave Unit is faulty.	Replace the Slave Unit. Replace the Master Unit if the problem recurs.

Common Mistakes The following table shows common connection mistakes and their remedies.

Mistake	Remedy
A terminator is not connected.	Connect a terminator (connector or terminal-block) at the end of the cable farthest from the Master.
The terminator is not connected at the end of the cable farthest from the Master.	Connect the terminator at the end of the cable farthest from the Master.
The master is not connected at one end of the main line of the system that has the main line distinguishable from the branch lines.	Connect the Master at one end of the main line.
The length of the main line, a branch line, or the total length of the branch lines of the system in which the main line must be distinguished from the branch lines is not within specifications.	Make sure that the lengths of the cables in the system are within the specifications listed in 2-2-2 <i>Maximum Cable Length</i> , or change the communications mode to Long-distance Communications Mode so that the length of the cables in the system will be within specifications.
The total communications cable in the system in which the main line does not need to be distinguished from the branch lines is not within specifications.	Refer to 2-2-2 <i>Maximum Cable Length</i> and change the configuration so that the length of the total communications cable length will be within specifications.
2-conductor VCTF cable, 4-conductor VCTF cable, and Special Flat Cable are used together in the same system.	Use just one kind of cable in the system.
There is a break in the communications cable.	Reconnect or replace the communications cable.
When 4-conductor VCTF cable or Special Flat Cable is being used, a connector is not attached securely to the cable.	Make sure that the connectors are crimped correctly on the cable.
A connector is faulty.	Replace the faulty connector.

6-5 Checking Slave Operations

6-5-1 Indicators

This section explains the indicators common to all of the Slave Units. In addition to these common indicators, Slaves have other indicators, such as indicators that reflect the status of the Slave's I/O point. Refer to *SECTION 5 Slave Specifications and Operations* for details on the indicators specific to each Slave.

Indicator Meanings

The following table shows the meaning of the common indicators.

Indicator	Color	Status	Meaning
PWR (POWER OUT)	Green	ON	The communications power supply is ON.
		OFF	The communications power supply is OFF.
COMM	Yellow	ON	Normal communications
		OFF	A communications error has occurred or the Unit is in standby status.
ERR (BUS/S ERR)	Red	ON	A communications error has occurred.
		OFF	Normal communications or the Unit is in standby status.

Indicator Status for Errors

The following table shows the status of the common indicators when an error occurs. Check the Master's indicators to determine the node number of the Slave in which the error occurred. The Slave's node number will also be indicated in the status area (not provided in CQM1 Master Units) allocated in the Special I/O Unit Area of the Master Unit.

Situation	Indicator status			Probable cause	Possible remedy
	PWR	COMM	ERR		
Slave's power OFF	OFF	OFF	OFF	The Slave's power is OFF.	Turn the Slave's power supply ON.
Data area overlap	ON	OFF	ON	With a CQM1 Master that's "number of points/node number" setting is set to 4, the same area may be allocated to more than one Slave. Communications will be stopped.	Check the area allocated to the 8-point Slave where the error occurred, eliminate the area overlap, and then restart the PLC.
Address over error	ON	ON	OFF	With a CQM1 Master that's "PLC word allocation" setting is 2 or 4 words, an out-of-range node number from 0 to 7 may have been set.	Check the Master's indicators to determine the node number and set the node number within the specified range.
Node number out-of-range error	ON	OFF	OFF	With a CQM1 Master, an out-of-range node number from 8 to 15 may have been set. When a CS-series, C200HX/C200HG/C200HE-(Z)E, and C200HS Master Unit, CS-series Master Unit, or CJ-series Master Unit is used and the range of usable node numbers is from 0 to 7, there are Slaves whose node numbers are set between 8 and 15.	Check the Master's indicators to determine the node number and set the node number within the specified range.
Communications mode conflict	ON	OFF	OFF	The communications mode setting of the Master Unit does not match that of the Slave.	Make the communications mode of the Master Unit and Slave agree, then power-up the Master Unit again.
Communications error	ON	OFF	ON	An error has occurred with a Slave during communications and it is withdrawn from the system.	Check the Master's indicators and clear the cause of the communications error.
Master's power OFF	ON	OFF	---	The Master's power is OFF.	Turn ON the Master's power supply.

Errors Limited to Analog Terminals

Situation	Indicator status				Probable cause	Possible remedy
	RUN	COMM	ERR	U.ERR		
Analog Terminal Error	ON	OFF	OFF	ON	An error has occurred in internal circuits of the CPU, analog-digital converter or digital-analog converter, etc.	Power-up the Slave again. If the Slave does not return to normal, replace it.

6-6 Cleaning and Inspection

This section describes the routine cleaning and inspection recommended as regular maintenance.

6-6-1 Cleaning

Clean the CompoBus/S regularly as described below in order to keep it in its optimal operating condition.

- Wipe the Unit with a dry, soft cloth for regular cleaning.
- When a spot cannot be removed with a dry cloth, dampen the cloth with a neutral cleanser, wring out the cloth, and wipe the Unit.
- A smudge may remain on the Unit from gum, vinyl, or tape that was left on for a long time. Remove the smudge when cleaning.

 **Caution** Never use volatile solvents such as paint thinner or benzene or chemical wipes. These substances could damage the surface of the Unit.

6-6-2 Inspection

Be sure to inspect the system periodically to keep it in optimal operating condition. In general, inspect the system once every 6 to 12 months, but inspect more frequently if the system is used with high temperature or humidity or under dirty/dusty conditions.

Inspection Equipment

Prepare the following equipment before inspecting the system.

Required Equipment

Have a standard and phillips screwdriver, multimeter, alcohol, and a clean cloth.

Equipment that Could be Needed

Depending on the system conditions, you might need a synchroscope, oscilloscope, thermometer, or hygrometer (to measure humidity).

Inspection Procedure

Check the items in the following table and correct any items that are below standard.

	Item	Standard	Equipment
Environmental conditions	Ambient and cabinet temperature	See below.	Thermometer
	Ambient and cabinet humidity	See below.	Hygrometer
	Dust/dirt accumulation	None	Visual inspection
Installation	Are the Units mounted securely?	No looseness	Phillips screwdriver
	Are the connecting cable connectors fully inserted?	No looseness	Phillips screwdriver
	Are the external wiring screws tight?	No looseness	Phillips screwdriver
	Are the connecting cables undamaged?	No damage	Visual inspection

The following table shows the acceptable operating temperature and operating humidity ranges for CompoBus/S Units.

Unit	Acceptable temperature	Acceptable humidity*
Master Unit	0 to 55°C	10% to 90%
Remote Terminal	0 to 55°C	35% to 85%
Remote I/O Module	0 to 55°C	35% to 85%
Sensor Amplifier Terminal	0 to 55°C	35% to 85%

Unit	Acceptable temperature	Acceptable humidity*
Sensor Terminal	0 to 55°C	35% to 85%
Fiber Amplifier Communications Unit	-20 to 55°C	35% to 85%
Connector Terminal	-10 to 55°C	25% to 85%
Water-resistant Terminal	-10 to 55°C	25% to 85%
Analog Terminal	-10 to 55°C	25% to 85%
CPM1A/CPM2A I/O Link Unit	0 to 55°C	10% to 90%
CPM2C I/O Link Unit	0 to 55°C	10% to 90%

Note Acceptable humidity range with no condensation or frost.

6-7 Precautions for Replacement of Units or Parts

The CompoBus/S Master Unit and Slave Units make up the system. The entire system is affected when a Unit is faulty, so a faulty Unit must be repaired or replaced quickly. We recommend having spare Units available to restore operation as quickly as possible.

6-7-1 Precautions for Unit Replacement

Observe the following precautions when replacing a faulty Unit.

- After replacement make sure that there are no errors with the new Unit.
- When a Unit is being returned for repair, attach a sheet of paper detailing the problem and return the Unit to your OMRON dealer.
- If there is a faulty contact, try wiping the contact with a clean, lint-free cloth dampened with alcohol. Re-mount the Unit after cleaning off any lint.

 **Caution** To prevent electric shock when replacing a Unit, be sure to turn OFF the power supplies to all of the nodes (Master and Slaves) before removing the faulty Unit.

6-7-2 Settings after Unit Replacement

After replacing a Unit, set the new Unit's switches to the same settings that were on the old Unit.

 **Caution** When the CPU Unit has been replaced, transfer any required DM Area or HR Area data to the new CPU Unit before restarting operation.

6-7-3 Replacing Relays

Faulty relays or power MOSFET relays in Remote Terminals can be removed and replaced.

 **Caution** Be sure to turn OFF the Slave's power supply before removing the faulty relay to prevent electric shock.
The relay's pins often bend or break when the relay is removed, so remove faulty relays only.

Remote Terminal Relays Use the following procedure to replace a relay in an Remote Terminal.

- 1,2,3...**
1. The relay removal tool attached to the Remote Terminal is used to remove the relay. Align the relay removal tool so that it squeezes the old relay, push it all the way in, and pull it out to remove the relay.

2. Check the orientation of the new relay carefully and insert it to the same depth as the other relays.

Appendix

Standard Models

Masters

Master Units

Model	Applicable PLCs
C200HW-SRM21-V1	CS-series, C200HX/C200HG/C200HE-(Z)E, and C200HS
CS1W-SRM21	CS-series
CJ1W-SRM21	CJ-series
CQM1-SRM21-V1	CQM1

SRM1 Master Control Units

Model	Specifications
SRM1-C01-V2	Dedicated CompoBus/S controller without RS-232C connector
SRM1-C02-V2	Dedicated CompoBus/S controller with RS-232C connector

CPM2C-S Programmable Controllers

Model	Specifications
CPM2C-S100C	CPU Unit with CompoBus/S Master functions, 6 transistor inputs, 4 transistor outputs (NPN)
CPM2C-S110C	CPU Unit with CompoBus/S Master functions, 6 transistor inputs, 4 transistor outputs (PNP)
CPM2C-S100C-DRT	CPU Unit with CompoBus/S Master functions, DeviceNet Slave functions, 6 transistor inputs, 4 transistor outputs (NPN)
CPM2C-S110C-DRT	CPU Unit with CompoBus/S Master functions, DeviceNet Slave functions, 6 transistor inputs, 4 transistor outputs (PNP)

Other Masters

Model	Specifications
3G8B3-SRM□1	CompoBus/S VME Board
C200PC-ISA□2-SRM	SYSMAC Board
SDD-CS1	Uniline CompoBus/S Send Unit, manufactured by NKE

Slaves

Remote Terminals

Model		Specifications
Compatible with High-speed Communications Mode	Compatible with High-speed and Long-distance Communications Modes	
SRT1-ID04	SRT2-ID04	4 transistor inputs, two independent power supplies (NPN)
SRT1-ID04-1	SRT2-ID04-1	4 transistor inputs, two independent power supplies (PNP)
SRT1-ID08	SRT2-ID08	8 transistor inputs, two independent power supplies (NPN)
SRT1-ID08-1	SRT2-ID08-1	8 transistor inputs, two independent power supplies (PNP)
SRT1-ID16	SRT2-ID16	16 transistor inputs, two independent power supplies (NPN)

Model		Specifications
Compatible with High-speed Communications Mode	Compatible with High-speed and Long-distance Communications Modes	
SRT1-ID16-1	SRT2-ID16-1	16 transistor inputs, two independent power supplies (PNP)
SRT1-ID16T	SRT2-ID16T	3-tier terminal block, 16 transistor inputs, two independent power supplies (NPN)
SRT1-ID16T-1	SRT2-ID16T-1	3-tier terminal block, 16 transistor inputs, two independent power supplies (NPN)
SRT1-OD04	SRT2-OD04	4 transistor outputs, two independent power supplies (NPN)
SRT1-OD04-1	SRT2-OD04-1	4 transistor outputs, two independent power supplies (PNP)
SRT1-OD08	SRT2-OD08	8 transistor outputs, two independent power supplies (NPN)
SRT1-OD08-1	SRT2-OD08-1	8 transistor outputs, two independent power supplies (PNP)
SRT1-OD16	SRT2-OD16	16 transistor outputs, two independent power supplies (NPN)
SRT1-OD16-1	SRT2-OD16-1	16 transistor outputs, two independent power supplies (PNP)
SRT1-OD16T	SRT2-OD16T	3-tier terminal block, 16 transistor outputs, two independent power supplies (NPN)
SRT1-OD16T-1	SRT2-OD16T-1	3-tier terminal block, 16 transistor outputs, two independent power supplies (NPN)
SRT1-MD16T	SRT2-MD16T	3-tier terminal block, 8 transistor inputs, 8 transistor outputs, two independent power supplies (NPN)
SRT1-MD16T-1	SRT2-MD16T-1	3-tier terminal block, 8 transistor inputs, 8 transistor outputs, two independent power supplies (NPN)
SRT1-ROC08	SRT2-ROC08	8 relay outputs, local power supply
SRT1-ROC16	SRT2-ROC16	16 relay outputs, local power supply
SRT1-ROF08	SRT2-ROF08	8 power MOS FET outputs, local power supply
SRT1-ROF16	SRT2-ROF16	16 power MOS FET outputs, local power supply

Connector Terminals

Model	Specifications
SRT2-VID08S	Connection with sensor connector (for cable connection), 8 transistor inputs, multiple power supplies (NPN)
SRT2-VID08S-1	Connection with sensor connector (for cable connection), 8 transistor inputs, multiple power supplies (PNP)
SRT2-VID16ML	Connection with MIL connector, 16 transistor inputs, multiple power supplies (NPN)
SRT2-VID16ML-1	Connection with MIL connector, 16 transistor inputs, multiple power supplies (PNP)
SRT2-ID32ML	Connection with MIL connector, 32 transistor inputs, multiple power supplies (NPN)
SRT2-ID32ML-1	Connection with MIL connector, 32 transistor inputs, multiple power supplies (PNP)
SRT2-MD32ML	Connection with MIL connector, 16 transistor inputs, 16 transistor outputs, multiple power supplies (NPN)
SRT2-MD32ML-1	Connection with MIL connector, 16 transistor inputs, 16 transistor outputs, multiple power supplies (PNP)
SRT2-VOD08S	Connection with sensor connector (for cable connection), 8 transistor outputs, multiple power supplies (NPN)
SRT2-VOD08S-1	Connection with sensor connector (for cable connection), 8 transistor outputs, multiple power supplies (PNP)
SRT2-VOD16ML	Connection with MIL connector, 16 transistor outputs, multiple power supplies (NPN)
SRT2-VOD16ML-1	Connection with MIL connector, 16 transistor outputs, multiple power supplies (PNP)
SRT2-OD32ML	Connection with MIL connector, 32 transistor outputs, multiple power supplies (NPN)
SRT2-OD32ML-1	Connection with MIL connector, 32 transistor outputs, multiple power supplies (PNP)

All models are compatible with both High-speed and Long-distance Communications Modes.

Remote I/O Modules

Model		Specifications
Compatible with High-speed Communications Mode	Compatible with High-speed and Long-distance Communications Mode	
SRT1-ID16P	SRT2-ID16P	Mounted to PCB, 16 inputs (NPN)
SRT1-OD16P	SRT2-OD16P	Mounted to PCB, 16 outputs (NPN)

Not compatible with Long-distance Communications Mode.

Sensor Amplifier Terminals

Model	Specifications
Compatible with High-speed Communications Mode	
SRT1-TID04S	4 inputs (1 channel × 4 units), Communications Terminal, network power supply
SRT1-TKD04S	4 inputs (4 channels × 1 unit), Communications Terminal, network power supply
SRT1-XID04S	4 inputs (1 channel × 4 units), Expansion Terminal
SRT1-XKD04S	4 inputs (4 channels × 1 unit), Expansion Terminal

Not compatible with Long-distance Communications Mode.

Fiber Amplifier Communications Unit

Model	Specifications
E3X-SRT21	8 inputs or 16 inputs (includes 2 status points) from Fiber Amplifier Unit, network power supply

This model is compatible with both High-speed and Long-distance Communications Modes.

Analog Terminals

Model	Specifications
SRT2-AD04	4 analog inputs (switchable between 4, 3, 2, and 1 points), network power supply
SRT2-DA02	2 analog outputs (switchable between 2 and 1 points), network power supply

Both models are compatible with both High-speed and Long-distance Communications Modes.

Sensor Terminals

Model		Specifications
Compatible with High-speed Communications Mode	Compatible with High-speed and Long-distance Communications Modes	
SRT1-ID08S	SRT2-ID08S	8 inputs, network power supply
SRT1-ND08S	SRT2-ND08S	4 inputs/4 outputs, network power supply
SRT1-OD08S	SRT2-OD08S	8 outputs, local power supply

Water-resistant Terminals

Model	Specifications
SRT2-ID04CL	Connection with shielded connector (round water-resistant connector), 4 transistor inputs (NPN), multiple power supplies, IP67 enclosure ratings
SRT2-ID04CL-1	Connection with shielded connector (round water-resistant connector), 4 transistor inputs (PNP), multiple power supplies, IP67 enclosure ratings
SRT2-ID08CL	Connection with shielded connector (round water-resistant connector), 8 transistor inputs (NPN), multiple power supplies, IP67 enclosure ratings
SRT2-ID08CL-1	Connection with shielded connector (round water-resistant connector), 8 transistor inputs (PNP), multiple power supplies, IP67 enclosure ratings
SRT2-OD04CL	Connection with shielded connector (round water-resistant connector), 4 transistor outputs (NPN), multiple power supplies, IP67 enclosure ratings
SRT2-OD04CL-1	Connection with shielded connector (round water-resistant connector), 4 transistor outputs (PNP), multiple power supplies, IP67 enclosure ratings
SRT2-OD08CL	Connection with shielded connector (round water-resistant connector), 8 transistor outputs (NPN), multiple power supplies, IP67 enclosure ratings
SRT2-OD08CL-1	Connection with shielded connector (round water-resistant connector), 8 transistor outputs (PNP), multiple power supplies, IP67 enclosure ratings

All models are compatible with both High-speed and Long-distance Communications Modes.

Bit Chain Terminal (Manufacturing Discontinued)

Model	Specifications
SRT1-B1T	8 inputs, 8 outputs (switchable between inputs and outputs in a batch), local power supply

Not compatible with Long-distance Communications Mode.

I/O Link Unit for CPM1A/CPM2A

Model	Specifications
CPM1A-SRT21	8 inputs, 8 outputs, data exchange with CPM1A/CPM2A CPU Units

This model is compatible with both High-speed and Long-distance Communications Modes.

I/O Link Unit for CPM2C

Model	Specifications
CPM2C-SRT21	8 inputs, 8 outputs, data exchange with CPM2C CPU Unit

This model is compatible with both High-speed and Long-distance Communications Modes.

Other Slaves

Model	Specifications
FND-X06H-SRT	Position Driver, 200-VAC input, 6 A
FND-X12H-SRT	Position Driver, 200-VAC input, 12 A
FND-X25H-SRT	Position Driver, 200-VAC input, 25 A
FND-X50H-SRT	Position Driver, 200-VAC input, 50 A
FND-X06L-SRT	Position Driver, 100-VAC input, 6 A
FND-X12L-SRT	Position Driver, 100-VAC input, 12 A

Not compatible with Long-distance Communications Mode.

• Slaves Manufactured by Other Companies

Model/Series	Specifications
VQ Series	SI manifold solenoid valve manufactured by SMC Corporation
SX Series	
SY Series	
MN4TB1 and MN4TB2 Series	Solenoid valve with reduced wiring manufactured by CKD Corporation
M4TB3 and M4TB4 Series	
M4G Series	
MN4S0 Series	
YS1A1, A2	Valve with reduced wiring manufactured by KOGANEI Corporation
YS2A1, A2	

Contact the manufacturer for details.

Standard Connection Devices

Communications Cables

Manufacturer	Model	Remarks
Commercially available		VCTF cable (JIS C3306), 2 conductors (0.75 mm ² each)
		VCTF cable (JIS C3306), 4 conductors (0.75 mm ² each)
OMRON	SCA1-4F10	OMRON Flat Cable, 100 m, 4 conductors (0.75 mm ² each)
Belden (U.S.A.)	#9409	Designated communications cable. (See note 1.)
Belden (U.S.A.)	#8489	Designated communications cable. (See note 2.)

- Note**
1. Electrical characteristics of the #9409 Belden communications cable are the same as those for the commercially available 2-conductor VCTF cable.
 2. Electrical characteristics of the #8489 Belden communications cable are the same as those for the commercially available 4-conductor VCTF cable.

Connectors

Model		Specifications
Branch Connector	SCN1-TH4	Use this connector to branch a cable. (Used with OMRON Flat Cable only.)
Extension Connector	SCN1-TH4E	Use this connector to extend the OMRON Flat Cable.
Connector Terminator	SCN1-TH4T	This connector has a built-in terminator. (Used with OMRON Flat Cable only.)
Round Water-resistant Connectors with Cable (socket and plug)	XS2W-D42□-□81-□	Use this connector to connect Water-resistant Terminals and T-joints. Can be used as a power supply cable (with the female socket connected to the Water-resistant Terminal). Can be used as an I/O cable for sensors that have connectors (with the male plug connected to the Water-resistant Terminal, if the product has a model number suffix "A").
Connector with Cable (female socket on one end)	XS2F-D42□-□80-□	A connector with cable used to connect Water-resistant Terminals to T-branch connectors. Can be used as a power supply cable (with the female socket connected to the Water-resistant Terminal) and the other end wired to a commercially available terminal block.
Connector with Cable (male plug on one end)	XS2H-D421-□80-A	A connector with cable used to connect Water-resistant Terminals to I/O devices. Can be used as an I/O cable (with the male plug connected to the Water-resistant Terminal) and the other end wired to the I/O device with loose wires.
Connector Socket Assembly (female) (Crimp terminals/Solder terminals)	XS2C-D4S7	A connector used to connect to the communications connectors or external power supply connectors of Water-resistant Terminals or T-joint plugs. Applicable cable dia.: 3 to 6 mm Applicable conductor size: 0.18 to 0.75 mm ²
	XS2C-D4□□	A connector used to connect to the external power supply connectors of Water-resistant Terminals or T-joint plugs. Applicable cable dia.: 3 to 6 mm Applicable conductor size: 0.18 to 0.3 or 0.5 to 0.75 mm ²
Connector Plug Assembly (male) (Crimp terminals/Solder terminals)	XS2G-D4S7	A connector used to connect to T-joint sockets. Applicable cable dia.: 6 to 8 mm Applicable conductor size: 0.18 to 0.75 mm ²
	XS2G-D4□□	A connector used to connect to I/O connectors of Water-resistant Terminals or T-joint sockets. Applicable cable dia.: 3 to 6 mm Applicable conductor size: 0.18 to 0.3 or 0.5 to 0.75 mm ²
T-joint	XS2R-D427-5	A joint used to T-branch a VCTF cable (e.g., a communications cable or power supply cable).
Communications Connector (6-pin)	FK-MCP1.5/6-STF-3.81	A communications connector for connecting CJ-series Master Units. Communications cables (BD H, BD L, BS+, BS-) and communications power lines (BS +, BS-) can be connected simultaneously. This connector has screwless terminals for signal lines and connector lock screws.
	MC1.5/6-STF-3.81	A communications connector for connecting CJ-series Master Units. Communications cables (BD H, BD L, BS+, BS-) and communications power lines (BS +, BS-) can be connected simultaneously. This connector has screw terminals for signal lines and connector lock screws.
Communications Connector (Connector Terminals)	BL3.5/6F (Product No. 160668)	Communications cables, communications power supply and I/O power supply connectors manufactured by Weidmuller Co., Ltd.
Shielded Terminator Plug (Male)	SRS2-1	A shielded terminator plug used to connect to T-joints.
Terminal-block Terminator	SRS1-T	This terminal block has a built-in terminator. (Can be used with 2- or 4-conductor VCTF cable and OMRON's Special Flat Cable.)

Other Products

Connector Terminal Mounting Brackets

SRT2-ATT01 Mounting Bracket A

SRT2-ATT02 Mounting Bracket B

Related Slaves: Connector Terminals

Cable Connectors

Related Slaves: Connector Terminals with Sensor Connectors, Remote Terminals with Connector Output Transistors, Sensor Terminals

Model	Marking	Applicable wire size
XS8A-0441	XS8-1	0.3 to 0.5 mm ²
XS8A-0442	XS8-2	0.14 to 0.2 mm ²

MIL Connectors

Related Slaves: Connector Terminals with MIL Connectors

Model	Remarks
XG4M-2030-T	MIL Connector for SRT2-V□D16ML (-1)
XG4M-4030-T	MIL Connector for SRT2-□D32ML (-1)

MIL Connector Cables for SRT2-V□D16ML(-1)

Slave model number	Connecting cable	Compatible product
SRT2-VID16ML	G79-150C (50 cm) G79-125C (25 cm)	G7TC-IA16/ID16
	G79-050C (50 cm) G79-025C (25 cm)	XW2D-20G6 XW2B-20G5/20G4
SRT2-VID16ML-1	G79-050C (50 cm) G79-025C (25 cm)	XW2D-20G6 XW2B-20G5/20G4
	SRT2-VOD16ML	G79-050C (50 cm) G79-025C (25 cm)
G70D Series		
G70R-SOC08		
G70A-ZOC16-3 and Relays		
XW2D-20G6 XW2B-20G5/20G4		
SRT2-VOD16ML-1	G79-150C (50 cm) G79-125C (25 cm)	G7TC-OC16-1
		G79-050C (50 cm) G79-025C (25 cm)
	G70A-ZOC16-4 and Relays	
	XW2D-20G6 XW2B-20G5/20G4	

MIL-compatible Cables for SRT2-□D32ML(-1)

Slave	MIL-compatible cable	Applicable models	Remarks
SRT2-ID32ML	G79-I50-25D1 (50 cm) G79-I75-50-D1 (75 cm)	G7TC-ID16 G7TC-IA16	
SRT2-OD32ML	G79-O50-25-D1 (50 cm) G79-O75-50-D1 (75 cm)	G7TC-OC16/OC08 G70D-SOC16/VSOC16 G70A-ZOC16-3	
SRT2-MD32ML	G79-M50-25-D1 (50 cm) G79-M75-50-D1 (75 cm)	Input: G7TC-ID16/-IA16 Output: G7TC-OC08/OC16 G70D-SOC16/VSOC16 G70A-ZOC16-3	I/O can be distinguished by color Input tubes: Red Output tubes: Yellow
SRT2-ID32ML-1	G79-I50-25-D2 (50 cm) G79-I75-50-D2 (75 cm)	G70A-ZIM16-5	
SRT2-OD32ML-1	G79-O50-25-D1 (50 cm) G79-O75-50-D1 (75 cm)	G70A-ZOC16-4 G70D-SOC16-1	
	G79-I50-25-D1 (50 cm) G79-I75-50-D1 (75 cm)	G7TC-OC16-4 M7F	
SRT2-MD32ML-1	G79-M50-25-D2 (50 cm) G79-M75-50-D2 (75 cm)	Input: G70A-ZIM16-5 Output: G70A-ZOC16-4 G70D-SOC16-1	I/O can be distinguished by color Input tubes: Red Output tubes: Yellow

I/O Connectors for External Power Supplies (Shield Round Water-resistant Connector for Water-resistant Terminals)

• Connectors for External Power Supplies

Connectors	Model
Connectors with Cable (female socket and plug)	XS2W-D42□-□81-□
Connector with Cable (socket on one end)	XS2F-D42□-□80-□
Connector Socket Assembly (female) (Crimp terminals/Solder terminals)	XS2C-D4□□

• I/O Connectors

Connector	Model
Connector with Cable (male plug on one end)	XS2H-D421-□80-A
Connectors with Cable (socket and plug)	XS2W-D42□-□81-A
Connector Plug Assembly (male) (Crimp terminals/Solder terminals)	XS2C-D4□□

Replaceable Relays

Relay	Model number	Units
Relay	G6D-1A	SRT2-ROC08 and SRT1-ROC16 Remote Terminals
Power MOS FET relay	G3DZ-2R6PL	SRT2-ROF08 and SRT1-ROF16 Remote Terminals

Fiber Amplifier Units

Model	Remarks
E3X-DA6 E3X-DAB6 E3X-DAG6 E3X-DA6TW E3X-DA8 E3X-DAB8 E3X-DAG8 E3X-DA8TW E39-TM1 E3X-DA6-P	Fiber Amplifier Units with Connectors: Note: Models with retractable cords (such as E3X-DA11/21/41/51-N and E3X-DAB11-N) and water-resistant models cannot be connected. Fiber Amplifier Units from specified lot numbers can also not be connected. Refer to the <i>Fiber Amplifier Unit Operation Manual</i> (Cat. No. Z152)

Index

A

- alarm output
 - CQM1, 378
- Analog Input Terminals
 - AD conversion data, 317
 - averaging function, 316
 - burnout detection function, 316
 - components, 309
 - dimensions, 318
 - DIP switch, 310
 - indicators, 310
 - input range, 313
 - internal circuitry, 312
 - models, 16, 389
 - node numbers, 311
 - used in CompoBus/S System, 8
 - wiring, 313
- Analog Output Terminals
 - components, 320
 - DA conversion data, 325
 - dimensions, 326
 - DIP switch, 320
 - models, 16, 389
 - node numbers, 321
 - output range, 323
 - specifications, 319, 320
 - used in CompoBus/S System, 8
 - wiring, 323
- averaging function, 316

B

- Branch Connector, 28
 - installation, 56
 - specifications, 19
- burnout detection function, 316

C

- C200HX, C200HG, C200HE, and C200HS PLCs, 78
 - I/O allocation, 78
 - Slave I/O status, 46, 50
- cables, 16
 - allowable current, 35
 - Cable Assemblies, 41, 64
 - connectors
 - assembling, 68
 - model numbers, 68
 - wiring and assembly, 67
 - details, 16
 - length, 29, 30, 37
 - models, 391
 - special flat cable, 24, 34
 - used in CompoBus/S System, 9, 10
 - VCTF, 24, 27, 33, 34
- checklists
 - operation, 70
- cleaning, 384

- communications
 - baud rate, 5
 - cable assembly, 64
 - cycle time, 5
 - errors, 377
 - modes, 3, 5, 13, 14, 29
 - Connector Terminals, 199, 217, 229, 239, 250
 - CPM2C-S Series, 144
 - Remote I/O Modules, 262
 - Remote Terminals, 189
 - Sensor Terminals, 271, 280
 - SRM1 Master Control Units, 140
 - SRT2 Series, 149, 160, 165, 176, 182, 262
 - power supply, 32
 - settings, 354
- CompoBus/S System
 - cables, 16, 37
 - communications, 24, 25
 - configuration, 6
 - connection example, 34
 - connection methods, 9, 27
 - main/branch line connections, 25
 - multidrop connections, 28
 - operations checklist, 70
 - power supply, 354
 - Slave Units, 7
 - startup checklist, 355
 - terminator connections, 31
 - with distinct main and branch lines, 8, 26, 27, 29, 31
 - with no distinction between main and branch lines, 9, 26, 27, 29, 31
- connections
 - Sensor Amplifier Terminals, 343
- Connector Terminals
 - communications mode settings, 199
 - components, 197
 - dimensions, 207
 - Mounting Brackets, 211, 235
 - indicators, 198
 - input devices and cables, 204
 - models, 15, 388
 - Mounting Brackets, 393
 - mounting, 208, 235
 - Mounting Brackets, 212
 - node numbers, 199
 - specifications, 194
 - transistor input
 - communications mode settings, 229
 - components, 227
 - dimensions, 234
 - DIP switch, 228
 - indicators, 228
 - input devices and cables, 233
 - internal circuitry, 229
 - node numbers, 228
 - specifications, 225
 - switch settings, 228
 - wiring, 230
 - transistor input and output
 - communications mode settings, 250
 - components, 248

- DIP switch, 249
 - indicators, 249
 - input devices and cables, 253
 - internal circuitry, 200
 - wiring, 251
 - transistor output
 - communications mode settings, 217, 239
 - components, 215, 237
 - dimensions, 225, 245, 255
 - DIP switch, 216, 238
 - indicators, 216, 238
 - input devices and cables, 222, 243
 - internal circuitry, 218, 240, 250
 - node numbers, 217, 238, 249
 - specifications, 213, 236, 246
 - switch settings, 238, 249
 - wiring, 220, 241
 - used in CompoBus/S System, 7
 - wiring, 202
 - Connector Terminator
 - installation, 62
 - specifications, 19
 - Connector Units
 - dimensions, 342
 - connectors
 - Branch Connector, 17
 - Connector Terminator, 17
 - details, 16, 41
 - Extension Connector, 17
 - installation, 55
 - models, 392
 - Terminal-block Terminator, 18
 - CPM2C-S Series
 - Master Unit dimensions, 142
 - setting node numbers, 144
 - setting the communications mode, 144
 - specifications, 140
 - CQM1
 - error detection with alarm output, 378
 - I/O allocation example, 134
 - I/O allocation in PLCs, 130, 136
 - Slave I/O status, 46, 50
- D**
- dimensions
 - Analog Input Terminals, 318
 - Analog Output Terminals, 326
 - Connector Terminals, 207, 234
 - Mounting Brackets, 211, 235
 - transistor input, 234
 - transistor input and output, 255
 - transistor output, 225, 245
 - Connector Units, 342
 - CPM2C-S Master Units, 142
 - Master Units
 - C200HX, C200HG, C200HE, and C200HS, 75
 - CQM1, 127
 - Remote I/O Modules, 268
 - Remote Terminals
 - relay/power MOS FET, 193, 194
 - transistor input, 156, 162
 - transistor input and output, 185
 - transistor output, 172, 178
 - Sensor Amplifier Terminals, 340
 - Sensor Terminals, 294, 301
 - SRM1 Master Control Units, 138
 - Water-resistant Terminals, 274, 283
- DIP switch
 - Analog Input Terminals, 310
 - Analog Output Terminals, 320
 - Connector Terminals
 - transistor input, 228
 - transistor output, 216, 238, 249
 - I/O Link Units, 328, 332
 - Master Units
 - C200HX, C200HG, C200HE, and C200HS, 77, 90, 107
 - CQM1, 129
 - Remote Terminals
 - relay/power MOS FET, 189
 - transistor input, 149
 - transistor input and output, 182
 - transistor output, 165
 - Sensor Amplifier Terminals, 338
 - Sensor Terminals, 290, 297
 - Water-resistant Terminals, 270, 279
- E**
- E3X-N Connectors
 - no-object teaching, 348
 - optical axis adjustment, 346
 - sensitivity settings, 346
 - with/without-object teaching, 348
 - EC Directives, xxi
 - errors
 - detection
 - CQM1, 378
 - Master Units
 - CQM1, 377
 - Slave Units, 383
 - Extension Connector
 - allowable current, 36
 - installation, 59
 - specifications, 19
- F**
- flags
 - status, 84, 97, 119, 358, 366
 - flat cables, 34
 - installation, 55
 - limitations, 35
- H**
- High-speed Communications Mode, 3, 5
 - used in CompoBus/S System, 8

I

I/O allocation
 Analog Terminals, 84, 97, 119
 C200HX, C200HG, C200HE, and C200HS PLCs, 78
 Connector Terminals, 232, 243
 CQM1
 example, 134

I/O Link Units
 communications mode settings, 329
 components, 328, 332
 DIP switch, 328, 332
 indicators, 328, 332
 models, 16, 390
 node numbers, 328, 332
 specifications, 327, 331
 terminal arrangement, 330, 333
 used in CompoBus/S System, 8
 wiring, 330, 333

I/O response times, 41
 characteristics, 41, 50
 maximum, 44, 48
 minimum, 42, 46

indicators
 Analog Input Terminals, 310
 Analog Output Terminals, 320
 Connector Terminals, 198
 transistor input, 228
 transistor input and output, 249
 transistor output, 216, 238
 I/O Link Units, 328, 332
 Master Units
 C200HX, C200HG, C200HE, and C200HS, 76, 89,
 106
 CQM1, 128
 Remote I/O Modules, 261
 Remote Terminals
 relay/power MOS FET, 189
 transistor input, 149
 transistor input and output, 181
 transistor output, 165, 175
 Sensor Amplifier Terminals, 338
 Sensor Terminals, 289, 296
 SRM1 Master Control Units, 139
 Water-resistant Terminals, 270, 279, 304

input range
 Analog Input Terminals, 313

inspecting, 384

installation
 Branch Connector, 56
 Connector Terminator, 62
 Extension Connector, 59
 flat cables, 55
 solderless connector, 66

intended audience, xvi

internal circuitry
 Analog Input Terminals, 312
 Connector Terminals
 transistor input, 229

 transistor input and output, 200, 250
 transistor output, 218, 240

Remote I/O Modules, 263

Remote Terminals
 relay/power MOS FET, 191
 transistor input, 150
 transistor input and output, 183
 transistor output, 166, 176

Sensor Amplifier Terminals, 339

Sensor Terminals, 291, 299

Water-resistant Terminals, 271, 280

L

Long-distance Communications Mode, 3, 5
 used in CompoBus/S System, 9

M

main line, 25

Master Units, 78
 communications modes, 13
 compatibility, 10
 components
 C200HX, C200HG, C200HE, and C200HS, 75
 CQM1, 128
 dimensions
 C200HX, C200HG, C200HE, and C200HS, 75
 CQM1, 127
 DIP switch
 C200HX, C200HG, C200HE, and C200HS, 77, 90,
 107
 CQM1, 129
 errors
 CQM1, 377

I/O allocation
 C200HX, C200HG, C200HE, and C200HS, 78
 CQM1, 130

in CompoBus/S System, 8, 9

indicators
 C200HX, C200HG, C200HE, and C200HS, 76, 89,
 106
 CQM1, 128

models, 13, 387

mounting, 54

node numbers, 131

number of points, 131

PLC word allocation, 131

rotary switch
 C200HX, C200HG, C200HE, and C200HS, 76, 90,
 107

settings, 78, 92, 114, 131

specifications
 C200HX, C200HG, C200HE, and C200HS, 74
 used in CompoBus/S System, 10

maximum switching capacity, xix

MIL connectors
 models, 393
 wiring and assembly, 258

models

Analog Input Terminals, 16, 389
Analog Output Terminals, 16, 389
cable connectors, 68, 393
communications cables, 391
Connector Terminals, 15, 388
 Mounting Brackets, 393
connectors, 392
I/O Link Units, 16, 390
list of standard models, 387
Master Units, 13, 387
MIL connectors, 393
Remote I/O Modules, 15, 389
Remote Terminals with Power MOS FETs, 15
Remote Terminals with Relays, 15
Remote Terminals with Transistors, 14
replaceable relays, 394
Sensor Amplifier Terminals, 389
Sensor Terminals, 15, 389
Slave Units, 14
SRM1 Master Control Units, 387
Water-resistant Terminals, 15, 390
mounting
 Connector Terminals, 208, 212, 235, 245, 255
 Mounting Brackets, 212
 Master Units, 54
 Slave Units, 54
multi-drop method, 28

N

node numbers
 Analog Input Terminals, 311
 Analog Output Terminals, 321
 Connector Terminals
 transistor input and output, 249
 transistor output, 238
display, 4
I/O Link Units, 328, 332
Remote I/O Modules, 262
Remote Terminals
 relay/power MOS FET, 190
Sensor Amplifier Terminals, 338
Sensor Terminals, 298
setting, 140, 144, 166, 175, 182, 199, 217, 228
noise protection
 Sensor Terminals, 266

P

power ON, 354
power supply
 arrangement, 39
 common, 33
 communications, 32
 for Slave Units, 31, 32, 38, 39
 independent, 33
 local, 32
 multiple power supplies for Slaves, 32
 network power supply, 32

 required for each Unit, 354
precautions
 application, xviii
 communications cables, xx
 general, xv, xvi
 operating environment, xvii
 safety, xvi

R

reference values, 187
 relay, 187
Remote I/O Modules
 components, 261
 dimensions, 268
 indicators, 261
 internal circuitry, 263
 models, 15, 389
 node numbers, 262
 specifications, 260
 terminal arrangement, 264
 used in CompoBus/S System, 7
 wiring, 264
Remote Terminals
 models, 14, 15
 relay/power MOS FET
 components, 188
 dimensions, 193, 194
 DIP switch, 189
 indicators, 189
 internal circuitry, 191
 node numbers, 190
 specifications, 185
 transistor input
 communications mode settings, 149
 components, 148
 dimensions, 156, 162
 DIP switch, 149
 indicators, 149
 internal circuitry, 150
 specifications, 147, 156
 terminal arrangement, 153
 wiring, 153
 transistor input and output
 components, 181
 DIP switch, 182
 indicators, 181
 internal circuitry, 183
 node numbers, 182
 specifications, 179, 180
 switch settings, 182
 terminal arrangement, 184
 wiring, 184
 transistor output
 components, 164, 174
 dimensions, 172, 178, 185
 DIP switch, 165, 175
 indicators, 165, 175
 internal circuitry, 166, 176
 node numbers, 166, 175

- specifications, 163, 173
- switch settings, 175
- terminal arrangement, 169
- wiring, 169
- used in CompoBus/S System, 7

replacing, 385

- relays, 385
- Units, 385

rotary switch

- Master Units
 - C200HX, C200HG, C200HE, and C200HS, 76, 90, 107

S

safety precautions, xvi

Sensor Amplifier Terminals

- components, 338
- connections, 343
- dimensions, 340
- DIP switch, 338
- E3X-N Connectors, 346
- indicators, 338
- internal circuitry, 339
- models, 389
- node numbers, 338
- specifications, 336
- terminal arrangement, 339
- wiring, 339

Sensor Terminals

- allowable voltage range, 38
- combinations, 335
- communications mode settings, 271, 280
- compatibility, 291
- components, 289, 296
- dimensions, 294, 301
- DIP switch, 290, 297
- external devices and cables, 298
- indicators, 289, 296
- internal circuitry, 291, 299
- models, 15, 389
- node numbers, 298
- noise protection, 266
- specifications, 287, 295
- terminal arrangement, 292
- used in CompoBus/S System, 7
- wiring, 292

shielded connectors

- wiring and assembly, 284

Slave Analog Terminals, 13

Slave Units

- allowable current, 36
- characteristics, 7
- errors, 383
- I/O response times, 42, 46
- I/O status at startup, 46, 50
- in CompoBus/S System, 8, 9
- local power supply, 16, 32
- models, 14

- mounting, 54

- multiple power supplies, 16, 32

- network power supply, 16, 32

solderless connector

- installation, 66

special flat cable, 24, 34

- allowable current, 35

- used for Slave Unit power supply, 34

specifications, 24

- Analog Output Terminals, 319

- Branch Connector, 19

- communications, 24

- Connector Terminals

- transistor input, 225

- transistor input and output, 246

- transistor input or output, 194

- transistor output, 213, 236

- Connector Terminator, 19

- CPM2C-S Series, 140

- Extension Connector, 19

- I/O Link Units, 327, 331

- Master Units

- C200HX, C200HG, C200HE, and C200HS, 74

- with built-in CPU, 12

- with communications functions, 10

- Remote I/O Modules, 260

- Remote Terminals

- relay/power MOS FET, 185

- transistor input, 147, 157

- transistor input and output, 179, 180

- transistor output, 163, 173

- Sensor Amplifier Terminals, 336

- Sensor Terminals, 287, 295

- SRM1 Master Control Units, 12, 136

- Terminal-block Terminator, 20

- Water-resistant Terminals, 268, 272, 277, 281

SRM1 Master Control Units

- dimensions, 138

- indicators, 139

- models, 387

- setting the communications mode, 140

- setting usable node numbers, 140

- specifications, 12, 136

status flags, 84, 97, 119, 358, 366

system configuration, 6

T

T-branch method, 27

terminal arrangement

- I/O Link Units, 330, 333

- Remote I/O Modules, 264

- Remote Terminals

- transistor input, 153, 161

- transistor input and output, 184

- transistor output, 169

- Sensor Amplifier Terminals, 339

- Sensor Terminals, 292

Terminal Block Connector, 28

Terminal-block Terminator
specifications, 20

terminators, 31
in CompoBus/S System, 9, 10

T-joints
allowable current, 36
used for CompoBus/S connections, 28

troubleshooting
Master Units, 360, 373

V

VCTF cable, 24, 27, 33
allowable current, 35
limitations, 35
used for Slave Unit power supply, 34
used in CompoBus/S System, 9, 10, 26

W

Water-resistant Terminals, 3
components, 270, 278, 303
dimensions, 274, 283
DIP switch, 270, 279
indicators, 270, 279, 304
internal circuitry, 271, 280
models, 15, 390
specifications, 268, 277
switch settings, 270, 279
used in CompoBus/S System, 7
wiring, 272, 281
wiring example, 41

wiring
Analog Input Terminals, 313
Analog Output Terminals, 323
Connector Terminals, 202
transistor input, 230
transistor input and output, 251
transistor output, 220, 241
I/O Link Units, 330, 333
Remote I/O Modules, 264
Remote Terminals
transistor input, 153
transistor input and output, 184
transistor output, 169
Sensor Amplifier Terminals, 339
Sensor Terminals, 292

Revision History

A manual revision code appears as a suffix to the catalog number on the front cover of the manual.

Cat. No. W266-E1-09

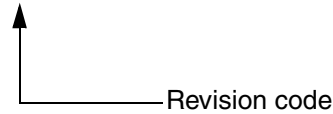

The following table outlines the changes made to the manual during each revision. Page numbers refer to the previous version.

Revision code	Date	Revised content
01	August 1996	Original production
02	June 1997	<p>Major revision mainly based on the addition of Slave Units (16-point Remote Terminals, Sensor Amplifier Terminals, Remote I/O Modules), changes in indication of the number of connectable Slaves (node number indication), etc.</p> <p>Pages xiii, xiv: Precautions added. <i>6 Conformance to EC Directives</i> added.</p> <p>Page 6: <i>1-2-2 System Configuration</i> added.</p> <p>Pages 6, 8, 60: Note 2 added.</p> <p>Page 7: Information on the new SRM1 Master Control Unit added. CQM1-CPU41-E/42-E/43-E/44-E changed to CQM1-CPU41-EV1/42-EV1/43-EV1/44-EV1 respectively.</p> <p>Page 10: Usable node number information added to the table.</p> <p>Page 12: Models added to the table.</p> <p>Pages 16 to 21, 32, 33: Node number information added.</p> <p>Page 31: Caution on EC Directives added.</p> <p>Page 32: Cautions added.</p> <p>Pages 35 to 44: Changes to the specifications made.</p> <p>Page 52: Remote I/O Module and Sensor Amplifier Terminal specifications added.</p> <p>Page 66: Table added to <i>C200HX, C200HG, C200HE, and C200HS Master Unit Installation</i>.</p> <p>Page 79: Remote I/O Module and Sensor Amplifier Terminal connection information added.</p> <p>Page 101: Models lists updated. <i>Communications Cable</i> added.</p>
03	June 1998	Pages 9, 14, 36, 39, 40, 42, 45, 47, 125: Information on PNP-type Remote Terminals added.
04	June 1999	Overall revision accompanying Master Unit version upgrade (supporting long-distance communications), Slave version upgrade (supporting long-distance communications), and the addition of Slave models (Remote Terminals, 3-tier Terminal Blocks, Connector Terminals, Analog Terminals, CPM1A/CPM2A I/O Link Unit).
05	February 2001	<p>Overall revision based on the following changes.</p> <p>Special Flat Cable for long-distance communications.</p> <p>Use of 4-conductor VCTF cable.</p> <p>CPM2C-S Master Unit added.</p> <p>Slaves added, including 32-point Connector Terminals, Water-resistant Terminals, and CPM2C I/O Link Units.</p>
06	November 2001	<p>Overall revision based on restructuring the manual and the following changes.</p> <p>CJ1W-SRM21 Master Unit added supporting new functions (Slave registration function and communications stop mode).</p> <p>Slaves added, including Fiber Amplifier Communications Units and Position Drivers.</p>

Revision History

Revision code	Date	Revised content
07	October 2003	<p>Additions and changes were made on the following pages:</p> <p>Page xvii: Note added under table.</p> <p>Page 2: Diagram changed to remove one of the terminators.</p> <p>Page 3: Corrected "CIO 2000" to "CIO 2002" in third row of table for OUT data.</p> <p>Page 6: Changed "CIO Area" to "I/O Area" in master characteristics.</p> <p>Page 31: Moved diagram to preceding subheading.</p> <p>Page 37: Changed order of symbol definitions for equations.</p> <p>Page 53: Added information and diagram on mounting direction</p> <p>Page 160: Swapped "V" and "G" terminals in specification for residual voltage, and removed information on leakage current for specific models.</p> <p>Page 172: Changed notes on COM terminals.</p> <p>Pages 173, 174: Corrected dimension from "50" to "51" in diagram.</p> <p>Page 193: Corrected "14" to "20.4" for I/O power supply voltage.</p> <p>Page 215: Changed diagram for horizontal panel mounting.</p> <p>Pages 254, 263, 264: Corrected dimension from "20" to "10" in diagram.</p>
08	October 2005	<p>"PC" was globally changed to "PLC" in the sense of "Programmable Controller."</p> <p>Page xiv: Precaution added toward bottom of page.</p> <p>Page xv: Precaution added toward top of page and precaution changed in middle of page.</p> <p>Page xvi: First indented bulleted text changed.</p> <p>Page 138 and 160: Input currents changed in table.</p> <p>Page 157: New note 2 added.</p>
09	August 2007	<p>Added information on the CS1W-SRM21 Master Unit for CS-series PLCs to relevant sections throughout the manual.</p> <p>Deleted information on Bit Chain Terminals due to discontinuation of manufacturing.</p>

Данный компонент на территории Российской Федерации

Вы можете приобрести в компании MosChip.

Для оперативного оформления запроса Вам необходимо перейти по данной ссылке:

<http://moschip.ru/get-element>

Вы можете разместить у нас заказ для любого Вашего проекта, будь то серийное производство или разработка единичного прибора.

В нашем ассортименте представлены ведущие мировые производители активных и пассивных электронных компонентов.

Нашей специализацией является поставка электронной компонентной базы двойного назначения, продукции таких производителей как XILINX, Intel (ex.ALTERA), Vicor, Microchip, Texas Instruments, Analog Devices, Mini-Circuits, Amphenol, Glenair.

Сотрудничество с глобальными дистрибьюторами электронных компонентов, предоставляет возможность заказывать и получать с международных складов практически любой перечень компонентов в оптимальные для Вас сроки.

На всех этапах разработки и производства наши партнеры могут получить квалифицированную поддержку опытных инженеров.

Система менеджмента качества компании отвечает требованиям в соответствии с ГОСТ Р ИСО 9001, ГОСТ РВ 0015-002 и ЭС РД 009

Офис по работе с юридическими лицами:

105318, г.Москва, ул.Щербаковская д.3, офис 1107, 1118, ДЦ «Щербаковский»

Телефон: +7 495 668-12-70 (многоканальный)

Факс: +7 495 668-12-70 (доб.304)

E-mail: info@moschip.ru

Skype отдела продаж:

moschip.ru

moschip.ru_4

moschip.ru_6

moschip.ru_9