



Features

- Broadband 50MHz to 1000MHz Operation
- 6-Bit Digital Step Attenuator
- Parallel Mode Gain Programming
- Max Gain=38.8dB at 140MHz
- Gain Control Range=31.5dB (0.5dB Step Size)
- High OIP3/P1dB=+42/20dBm at 140MHz
- Single +5V Supply
- 3V or 5V Logic Level Compatible
- Small 32-Pin, 5.2mmx5.2mm, MCM
- Footprint Compatible with 5mmx5mm 32-Pin QFN

Applications

- Linear IF Applications
- Cellular, 3G Infrastructure
- WiBro, WiMAX, LTE
- Microwave Radio
- High Linearity Power Control

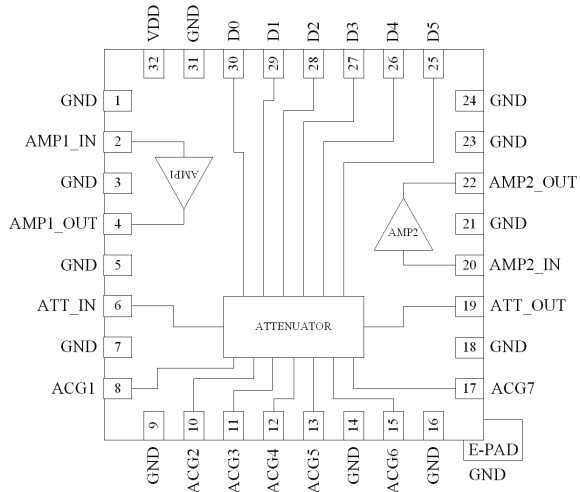

Functional Block Diagram

RFMD's RDA2032Z is a digital controlled variable gain amplifier (DVGA) featuring high linearity over the entire gain control range. The attenuation of the 6-bit digital step attenuator is programmed with a parallel mode control interface. The RDA2032Z has two amplifier stages packaged in a small 5.2mmx5.2mm leadless laminate MCM containing plated through thermal vias for ultra low thermal resistance. The footprint for this module is directly compatible with a 5mmx5mm 32-pin QFN. This module is easy to use with no external matching components required.

Optimum Technology Matching® Applied

- | | | | |
|---|--------------------------------------|--|------------------------------------|
| <input type="checkbox"/> GaAs HBT | <input type="checkbox"/> SiGe BiCMOS | <input checked="" type="checkbox"/> GaAs pHEMT | <input type="checkbox"/> GaN HEMT |
| <input type="checkbox"/> GaAs MESFET | <input type="checkbox"/> Si BiCMOS | <input type="checkbox"/> Si CMOS | <input type="checkbox"/> BiFET HBT |
| <input checked="" type="checkbox"/> InGaP HBT | <input type="checkbox"/> SiGe HBT | <input type="checkbox"/> Si BJT | <input type="checkbox"/> LDMOS |

RF MICRO DEVICES®, RFMD®, Optimum Technology Matching®, Enabling Wireless Connectivity™, PowerStar®, POLARIS™ TOTAL RADIO™ and UltimateBlue™ are trademarks of RFMD, LLC. BLUETOOTH is a trademark owned by Bluetooth SIG, Inc., U.S.A. and licensed for use by RFMD. All other trade names, trademarks and registered trademarks are the property of their respective owners. ©2006, RF Micro Devices, Inc.

Absolute Maximum Ratings

Parameter	Rating	Unit
Supply Voltage	5.5	V
DC Supply Current	228	mA
Power Dissipation	1054	mW
Max Input RF Power	+24	dBm
Operating Temperature	-40 to +85	°C
Storage Temperature	-40 to +150	°C
Junction Temperature (T _J)	+150	°C
ESD Rating (HBM)	500 (Class 1B)	V
Moisture Sensitivity Level (MSL)	3	



Caution! ESD sensitive device.

Exceeding any one or a combination of the Absolute Maximum Rating conditions may cause permanent damage to the device. Extended application of Absolute Maximum Rating conditions to the device may reduce device reliability. Specified typical performance or functional operation of the device under Absolute Maximum Rating conditions is not implied.

RoHS status based on EU Directive 2002/95/EC (at time of this document revision).

The information in this publication is believed to be accurate and reliable. However, no responsibility is assumed by RF Micro Devices, Inc. ("RFMD") for its use, nor for any infringement of patents, or other rights of third parties, resulting from its use. No license is granted by implication or otherwise under any patent or patent rights of RFMD. RFMD reserves the right to change component circuitry, recommended application circuitry and specifications at any time without prior notice.

Parameter	Specification			Unit	Condition
	Min.	Typ.	Max.		
Overall					Temp=25 °C, V _{CC} =V _{DD} =5V, V _{CTL} =TTL Logic, Tested With Evaluation Circuit
Frequency Range	50		1000	MHz	
Gain Max at 140MHz		38.8		dBm	Attenuation=0dB
Gain Control Range		31.5		dB	0.5dB step
Step Accuracy	±(0.15 + 3% attenuation setting)			dB	Major state max error up to 1000MHz
OP1dB at 140MHz		20		dBm	Attenuation=0dB
OIP3 at 140MHz		42		dBm	P _{OUT} =0dBm/tone, 1MHz spacing
Control Interface		6			Parallel mode 6-bit
Settling Time		220		ns	t _{ON} , t _{OFF} (10%/90% RF)
NF at 140MHz		3.2		dB	Attenuation=0dB
Input Return Loss at 140MHz		-30		dB	50Ω system
Output Return Loss at 140MHz		-25		dB	50Ω system
Amplifier Supply Voltage (V _{CC})	4.75	5.0	5.25	V	
Attenuator Supply Voltage (V _{DD})	3.0	5	5.25	V	
Total Supply Current	164	182	204	mA	Sum of currents from V _{DD} and V _{CC}
Thermal Resistance		39		°C/W	

Typical RF Performance at Key Operating Frequencies

Parameter	Unit	50MHz	140MHz	280MHz	500MHz	850MHz	1000MHz
Max Small Signal Gain	dB	39.5	38.8	38.5	37.8	36.5	36.0
OP1dB	dBm	19.5	20.0	20.0	20.0	19.8	19.6
OIP3	dBm	40.0	42.0	42.0	39.5	36.0	35.0
Input Return Loss	dB	-20	-30	-20	-19	-16	-15
Output Return Loss	dB	-30	-28	-23	-20	-11.5	-10
NF	dB	3.1	3.2	3.3	3.3	3.3	3.3

Typical Performance

Max Gain

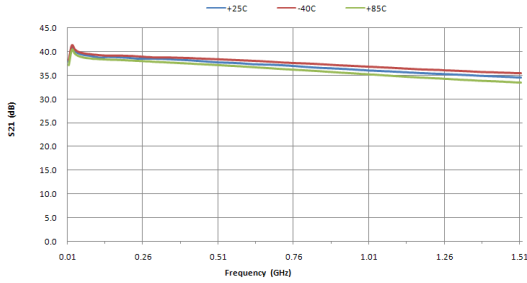

Normalized Attenuation

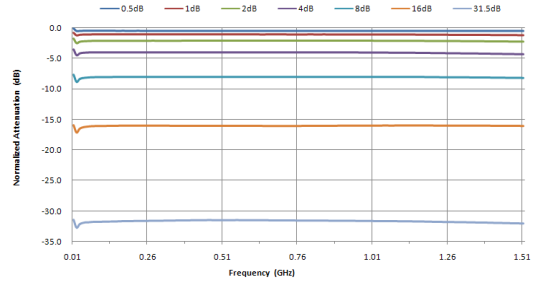

Input Return Loss

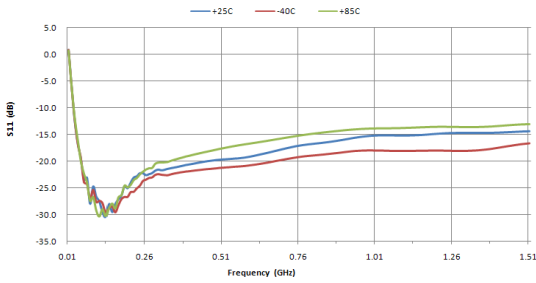

Input Return Loss at Major Gain Steps

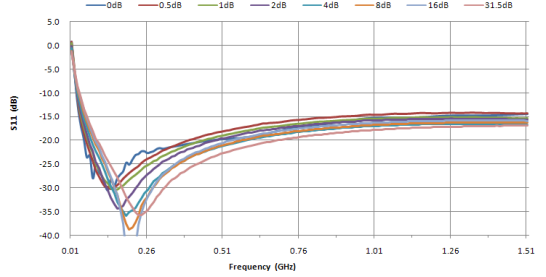

Output Return Loss at Major Gain Steps

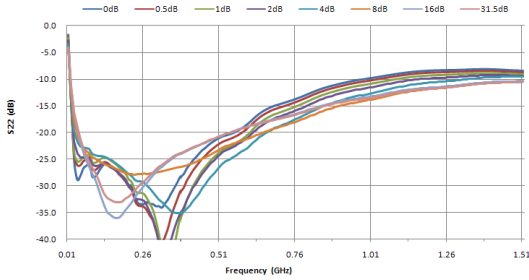

Output Return Loss

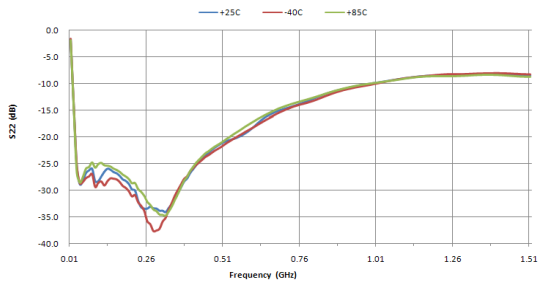

Typical Performance

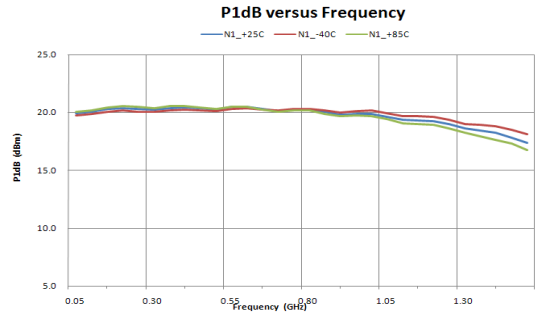
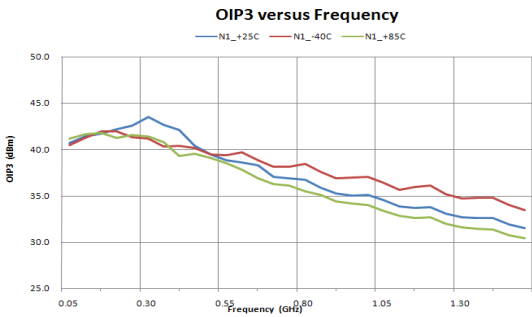
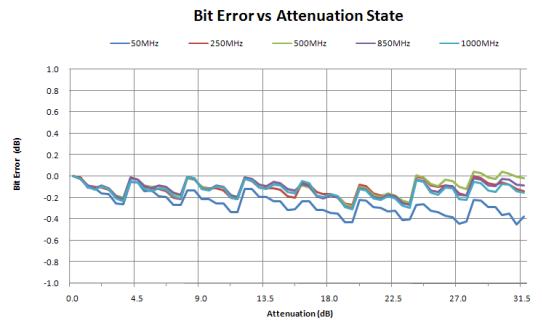
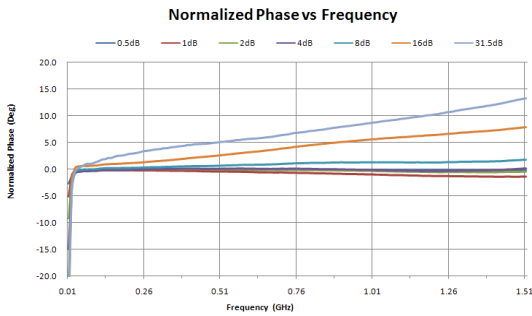
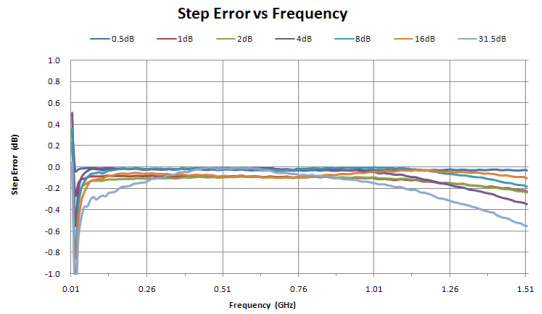
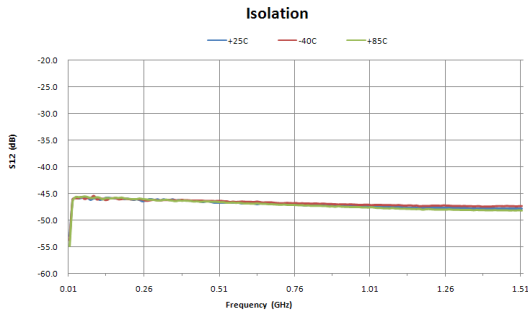

Typical Performance

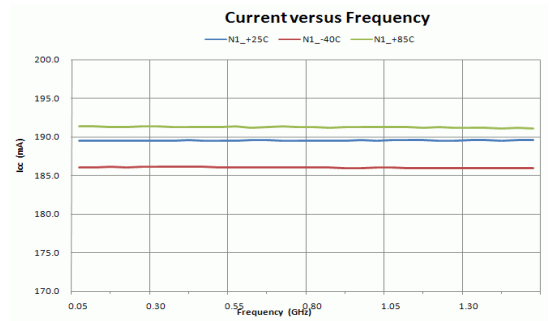
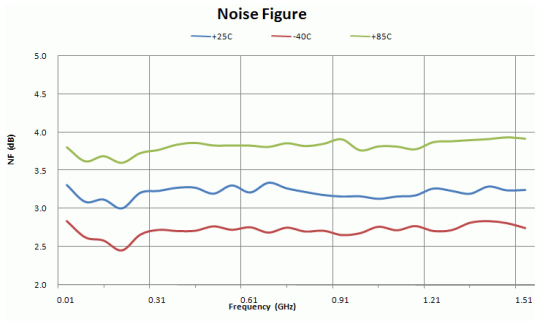

Truth Table

Control Bit						Gain Relative to Maximum Gain
D5	D4	D3	D2	D1	D0	
1	1	1	1	1	1	0dB
1	1	1	1	1	0	-0.5dB
1	1	1	1	0	1	-1dB
1	1	1	0	1	1	-2dB
1	1	0	1	1	1	-4dB
1	0	1	1	1	1	-8dB
0	1	1	1	1	1	-16dB
0	0	0	0	0	0	-31.5dB

Logic Voltage Levels		
State	V _{DD} =+3.3V	V _{DD} =+5V
Low	0V to 0.8V	0V to 0.8V
High	2.0V to V _{DD}	2.0 to V _{DD}

Functional Block Diagram

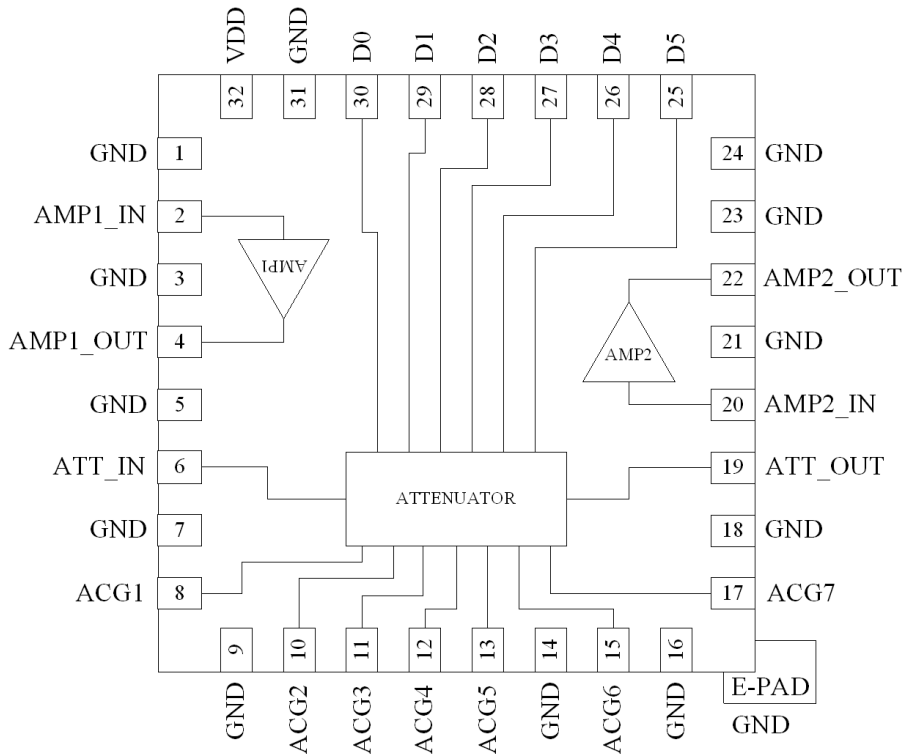

Pin	Function	Description
1	GND	RF/DC Ground Connection.
2	AMP1_IN	RF Amplifier 1 Input. DC block required.
3	GND	RF/DC Ground Connection.
4	AMP1_OUT	RF Amplifier 1 Output. DC block required.
5	GND	RF/DC Ground Connection.
6	ATT_IN	Digital Attenuator Input. DC block required.
7	GND	RF/DC Ground Connection.
8	ACG1	Place external capacitor to ground.
9	GND	RF/DC Ground Connection.
10	ACG2	Place external capacitor to ground.
11	ACG3	Place external capacitor to ground.
12	ACG4	Place external capacitor to ground.
13	ACG5	Place external capacitor to ground.
14	GND	RF/DC Ground Connection.
15	ACG6	Place external capacitor to ground.
16	GND	RF/DC Ground Connection.
17	ACG7	Place external capacitor to ground.
18	GND	RF/DC Ground Connection.
19	ATT_OUT	Digital Attenuator Output. DC block required.
20	AMP2_IN	RF Amplifier 2 Input. DC block required.
21	GND	RF/DC Ground Connection.
22	AMP2_OUT	RF Amplifier 2 Output. DC block required.
23	GND	RF/DC Ground Connection.
24	GND	RF/DC Ground Connection.
25	D5	Digital attenuator parallel control line: 16dB bit.
26	D4	Digital attenuator parallel control line: 8dB bit.
27	D3	Digital attenuator parallel control line: 4dB bit
28	D2	Digital attenuator parallel control line: 2dB bit.
29	D1	Digital attenuator parallel control line: 1dB bit.
30	D0	Digital attenuator parallel control line: 0.5dB bit.
31	GND	RF/DC Ground Connection.
32	VDD	Digital attenuator supply Voltage.

Package Drawing

5.2mmx5.2mm Laminate Module

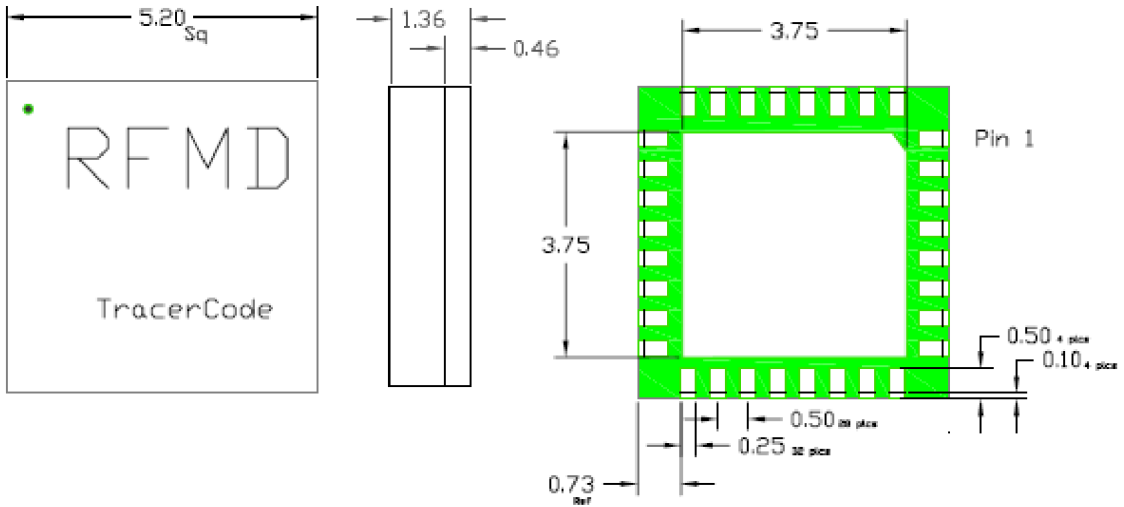

Note: Module thickness tolerance = ± 0.04 mm. Other dimension tolerances = ± 0.075 mm.

Branding Diagram

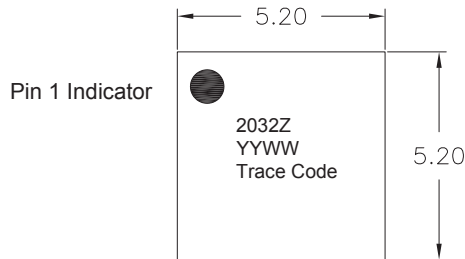

Evaluation PCB

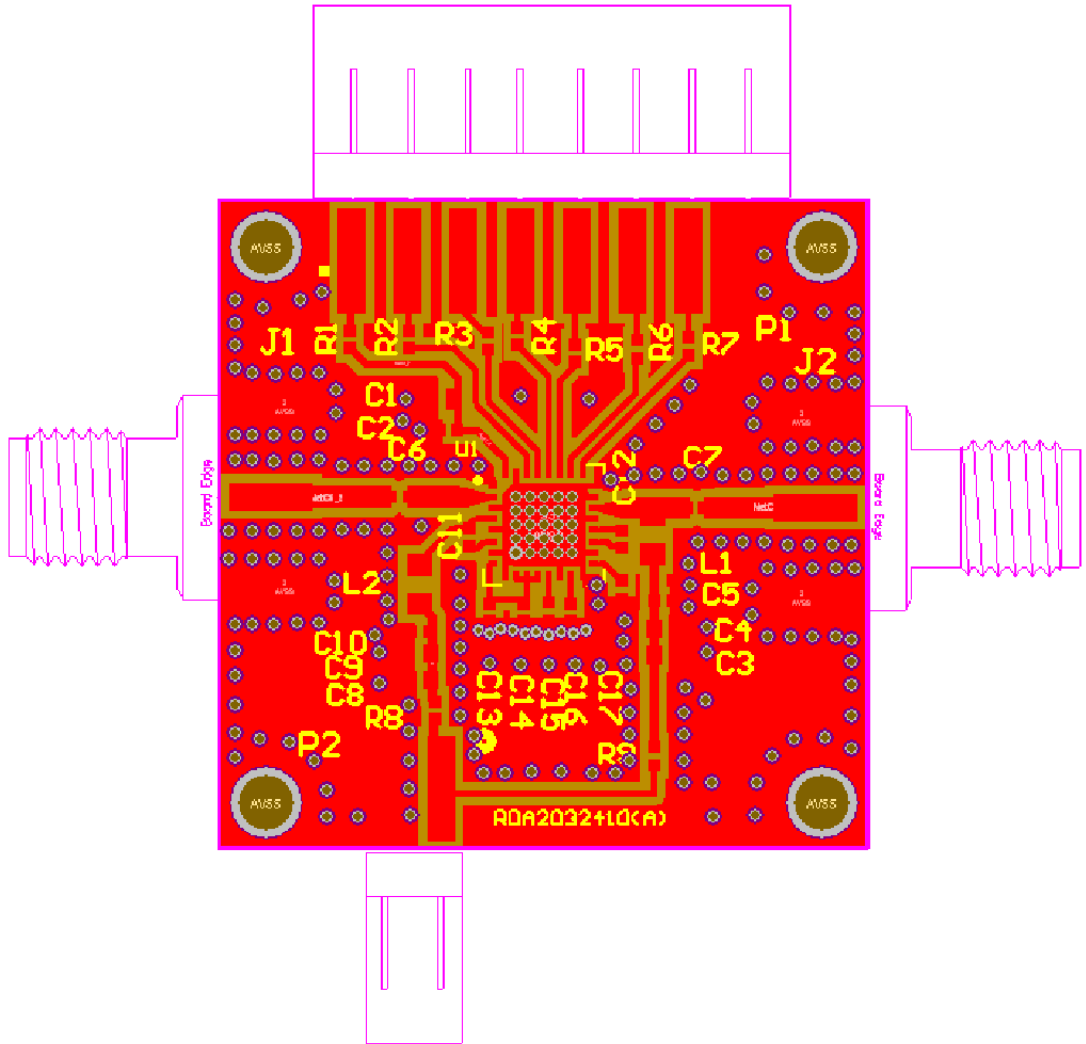

Evaluation Board Schematic

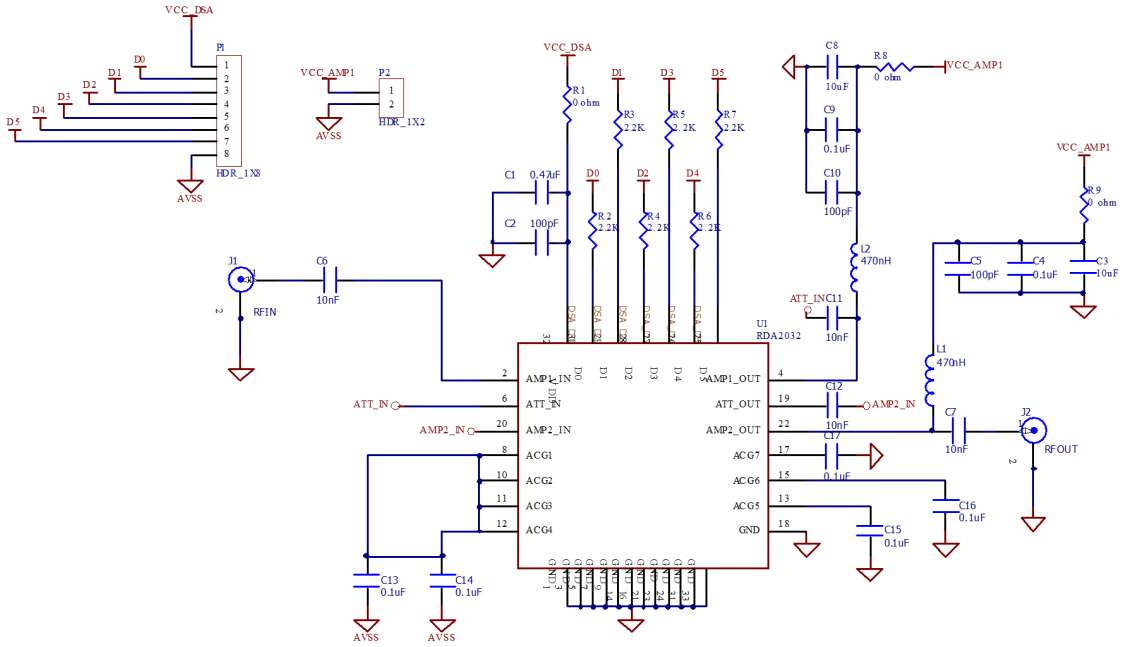

Bill of Materials

Quantity	Description	Reference Designator	Manufacturer	Manufacturer's Part Number
1	CAP, 0.47uF, 10%, 10V, X5R, 0603	C1	Murata Electronics	GRM188R61A47K61D
2	CAP, 10uF, 20%, 6.3V, X5R, 0603	C3, C8	Murata Electronics	GRM188R60J106ME47D
2	CAP, 0.1uF, 10%, 16V, X7R, 0603	C4, C9	Murata Electronics	GRM188R71C104KA01D
3	CAP, 100pF, 5%, 50V, C0G, 0402	C2, C10, C5	Panasonic	ECJ-OEC1H101J
5	CAP, 0.1uF, 10%, 10V, X5R, 0402	C13, C14, C15, C16, C17	Taiyo Yuden	RM LMK105BJ104KV
4	CAP, 10000pF, 10%, 16V, X7R, 0402	C6, C7, C11, C12	Taiyo Yuden	RM EMK105BJ103KV-F
2	IND, 470nH, 10%, W/W, 0805	L1, L2	Coilcraft	0805LS-471XSLB
2	JMPR, 0 OHM, 0402	R1, R8, R9	Panasonic	ERJ-2GE0R00
6	RES, 2.2K, 5%, 1/16W, 0402	R2, R3, R4, R5, R6, R7	Panasonic	ERJ-2GEJ222

Ordering Information

Ordering Code	Description
RDA2032ZSQ	Sample bag with 25 pieces
RDA2032ZSR	7" Reel with 100 pieces
RDA2032ZTR7	7" Reel with 750 pieces
RDA2032ZTR13	13" Reel with 2500 pieces
RDA2032ZPCK-410	50MHz to 1000MHz PCBA with 5-piece sample bag

Данный компонент на территории Российской Федерации

Вы можете приобрести в компании MosChip.

Для оперативного оформления запроса Вам необходимо перейти по данной ссылке:

<http://moschip.ru/get-element>

Вы можете разместить у нас заказ для любого Вашего проекта, будь то серийное производство или разработка единичного прибора.

В нашем ассортименте представлены ведущие мировые производители активных и пассивных электронных компонентов.

Нашей специализацией является поставка электронной компонентной базы двойного назначения, продукции таких производителей как XILINX, Intel (ex.ALTERA), Vicor, Microchip, Texas Instruments, Analog Devices, Mini-Circuits, Amphenol, Glenair.

Сотрудничество с глобальными дистрибьюторами электронных компонентов, предоставляет возможность заказывать и получать с международных складов практически любой перечень компонентов в оптимальные для Вас сроки.

На всех этапах разработки и производства наши партнеры могут получить квалифицированную поддержку опытных инженеров.

Система менеджмента качества компании отвечает требованиям в соответствии с ГОСТ Р ИСО 9001, ГОСТ РВ 0015-002 и ЭС РД 009

Офис по работе с юридическими лицами:

105318, г.Москва, ул.Щербаковская д.3, офис 1107, 1118, ДЦ «Щербаковский»

Телефон: +7 495 668-12-70 (многоканальный)

Факс: +7 495 668-12-70 (доб.304)

E-mail: info@moschip.ru

Skype отдела продаж:

moschip.ru

moschip.ru_4

moschip.ru_6

moschip.ru_9