

LOW VOLTAGE OPERATION DUAL H BRIDGE DRIVER

■ GENERAL DESCRIPTION

The NJU7381A is a dual H-bridge driver IC that features low voltage operation and low quiescent current.

The control method is 2 logic Inputs (2-IN) that includes standby mode.

The independent comparator circuit can be used for position sensing signal processing and the others.

Small package makes the NJU7381A suitable for small stepper motor and DC motor, such as portable applications.

■ PACKAGE OUTLINE

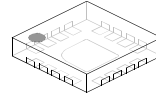

NJU7381AMJE
(EQFN16-JE)

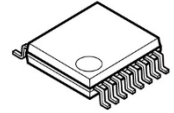

NJU7381AV
(SSOP16)

■ FEATURES

- Supply Voltage : $V_{DD}=1.8V$ to $5.5V$
- Output Current : $I_O=200mA$ (Continuous)
 $I_O=400mA$ (Peak)
- Output ON Resistance : $R_{O(H+L)}=1.25\Omega$ typ. at $V_{DD}=3.3V$
 $R_{O(H+L)}=1.95\Omega$ typ. at $V_{DD}=1.8V$
- Low Quiescent Current : $60\mu A$ typ. at $V_{DD}=3.3V$
- 2 Logic Inputs Control (2-IN)
- Stand-by Function (At no-input signal)
- Built-in Comparator Circuit
- Protection Circuit : Thermal Shutdown Circuit (TSD)
- Package Outline : EQFN16-JE, SSOP16

■ BLOCK DIAGRAM

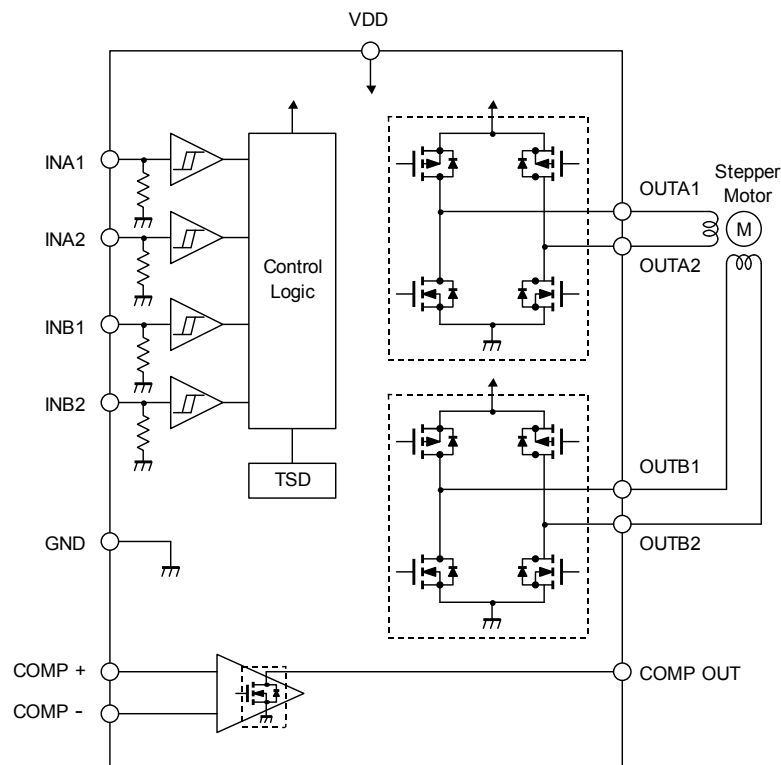

NJU7381A

■ PIN CONFIGURATION

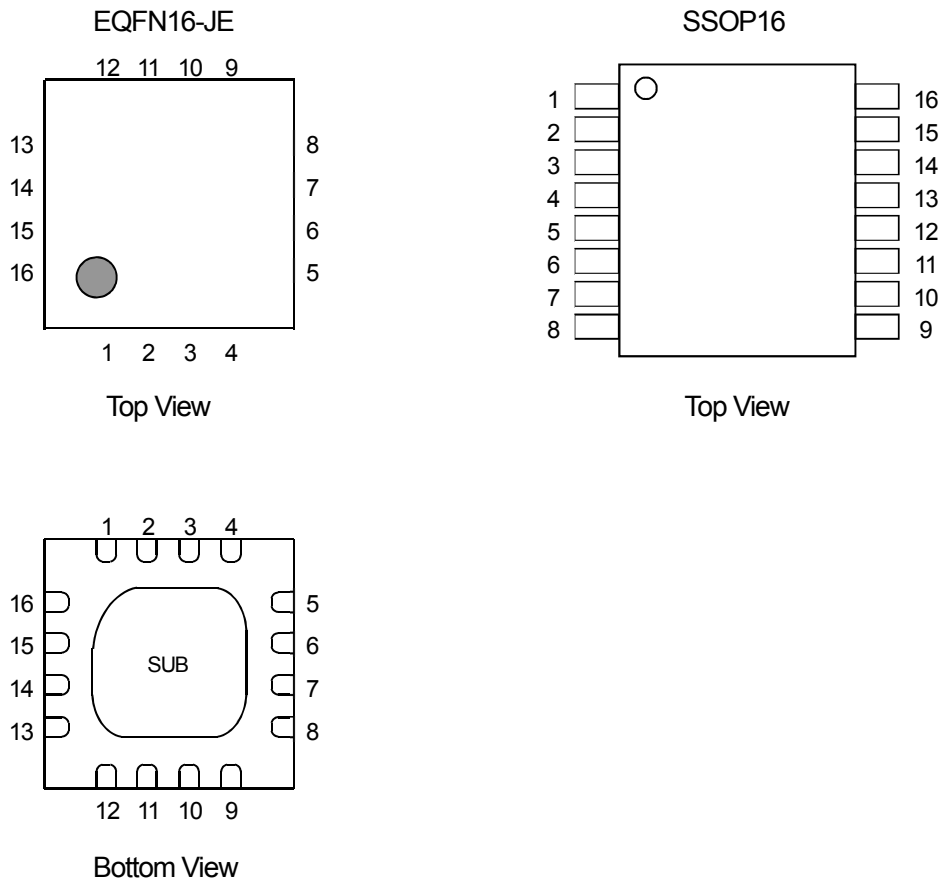

■ PIN DESCRIPTION

PIN No.		PIN NAME	FUNCTION	NOTES
EQFN16	SSOP16			
1	2	INB1	Bch Logic Input Pin 1	-
2	3	INB2	Bch Logic Input Pin 2	-
3,11	4,12	VDD	Power Supply Pin	Both pins must be connected together externally.
4	5	INA2	Ach Logic Input Pin 2	-
5	6	INA1	Ach Logic Input Pin 1	-
6	7	OUTA2	Ach Output Pin 2	-
7,15	8,16	GND	Ground Pin	Both pins must be connected together externally.
8	9	OUTA1	Ach Output Pin 1	-
9	11	COMP OUT	Comparator Output Pin	When not using, it should be set to open.
10	10	NC	No Connection	Not Internally Connected
12	13	COMP+	Comparator Non-inverted Input Pin	When not using, it should be connected to VDD.
13	14	COMP-	Comparator Inverted Input Pin	When not using, it should be connected to GND.
14	15	OUTB1	Bch Output Pin 1	-
16	1	OUTB2	Bch Output Pin 2	-
SUB	-	SUB	Back Side Thermal PAD (SUB)	The PAD is connected with the internal VDD. It must be set to open or connected to VDD.

■ ABSOLUTE MAXIMUM RATINGS

(Ta=25°C)

PARAMETER	SYMBOL	RATINGS	UNIT	NOTES
Supply Voltage	V _{DD}	7	V	-
Logic Input Voltage	V _{ID}	-0.3 to V _{DD} +0.3	V	-
Motor Output Current (Peak)	I _{OPEAK}	400	mA	Per channel
		800	mA	Ach & Bch parallel connection
Comparator Output Current	I _{CO}	10	mA	-
Comparator Output Voltage	V _{CO}	7	V	-
Operating Ambient Temperature	T _{opr}	-40 to +85	°C	-
Junction Temperature	T _j	-40 to +150	°C	-
Storage Temperature	T _{stg}	-50 to +150	°C	-
Power Dissipation (EQFN16-JE)	P _D	720	mW	2 Layers on PCB (*1)
		1800		4 Layers on PCB (*2)
Power Dissipation (SSOP16)	P _D	300	mW	Device itself
		610		2 Layers on PCB (*3)
		780		4 Layers on PCB (*4)

*1: Mounted on glass epoxy board based on EIA/JEDEC. (101.5×114.5×1.6mm, FR-4, 2Layers, connected exposed PAD)

*2: Mounted on glass epoxy board on EIA/JEDEC. (101.5×114.5×1.6mm, FR-4, 4Layers, Inner Cu area : 99.5×99.5mm, In addition thermal via holes, connected exposed PAD)

*3: Mounted on glass epoxy board based on EIA/JEDEC. (76.2×114.3×1.6mm, FR-4, 2Layers)

*4: Mounted on glass epoxy board based on EIA/JEDEC. (76.2×114.3×1.6mm, FR-4, 4Layers, Inner Cu area : 74.2×74.2mm)

■ RECOMMENDED OPERATING CONDITIONS

(V_{DD}=3.3V, Ta=25°C)

PARAMETER	SYMBOL	TEST CONDITIONS	MIN.	TYP.	MAX.	UNIT
Supply Voltage 1	V _{DD1}	Not using comparator block (*5)	1.8	-	5.5	V
Supply Voltage 2	V _{DD1}	Using comparator block (*5)	2.0	-	5.5	V
Motor Output Current (Continuous)	I _o	Per channel	-	-	200	mA
		Ach & Bch parallel connection	-	-	400	mA

*5: Output voltage may not be provided enough depending on output current level, please review output ON resistance spec.

NJU7381A

■ ELECTRICAL CHARACTERISTICS

($V_{DD}=3.3V$, $T_a=25^{\circ}C$)

PARAMETER	SYMBOL	TEST CONDITIONS	MIN.	TYP.	MAX.	UNIT
■ GENERAL						
Quiescent Current 1	I_{DD1}		-	60	120	μA
Quiescent Current 2	I_{DD2}	$V_{DD}=1.8V$	-	50	100	μA
Quiescent Current at Stand-by	I_{STB}		-	1	3	μA
Thermal Shutdown Temperature	T_{TSD}		-	190	-	$^{\circ}C$
Thermal Shutdown Hysteresis	T_{HYS}		-	40	-	$^{\circ}C$
■ LOGIC BLOCK						
H Level Input Voltage 1	V_{IH1}		2.4	-	V_{DD}	V
H Level Input Voltage 2	V_{IH2}	$V_{DD}=1.8V$	1.4	-	V_{DD}	V
L Level Input Voltage 1	V_{IL1}		0	-	0.8	V
L Level Input Voltage 2	V_{IL2}	$V_{DD}=1.8V$	0	-	0.4	V
Input Hysteresis Width	V_{IHYS}		-	0.2	-	V
H Level Input Current	I_{IH}	Per 1 Input	22	33	55	μA
L Level Input Current	I_{IL}	Per 1 Input	-	-	200	nA
Input Pull Down Resistance	R_{IN}		60	100	150	k Ω
Input Pulse Width	tp		2	-	-	μs
■ DRIVER BLOCK						
High Side Output ON Resistance 1	R_{ONH1}	$I_O=200mA$	-	0.75	1.0	Ω
High Side Output ON Resistance 2	R_{ONH2}	$V_{DD}=2.1V$, $I_O=200mA$	-	1.0	1.35	Ω
High Side Output ON Resistance 3	R_{ONH3}	$V_{DD}=1.8V$, $I_O=200mA$	-	1.2	1.6	Ω
Low Side Output ON Resistance 1	R_{ONL1}	$I_O=200mA$	-	0.5	0.7	Ω
Low Side Output ON Resistance 2	R_{ONL2}	$V_{DD}=2.1V$, $I_O=200mA$	-	0.65	0.9	Ω
Low Side Output ON Resistance 3	R_{ONL3}	$V_{DD}=1.8V$, $I_O=200mA$	-	0.75	1.05	Ω
Parallel Connection High Side Output ON Resistance 1	R_{PONH1}	Ach & Bch Parallel Connection, $I_O=400mA$	-	0.38	0.5	Ω
Parallel Connection High Side Output ON Resistance 2	R_{PONH2}	Ach & Bch Parallel Connection, $V_{DD}=2.1V$, $I_O=400mA$	-	0.5	0.68	Ω
Parallel Connection High Side Output ON Resistance 3	R_{PONH3}	Ach & Bch Parallel Connection, $V_{DD}=1.8V$, $I_O=400mA$	-	0.6	0.8	Ω
Parallel Connection Low Side Output ON Resistance 1	R_{PONL1}	Ach & Bch Parallel Connection, $I_O=400mA$	-	0.25	0.35	Ω
Parallel Connection Low Side Output ON Resistance 2	R_{PONL2}	Ach & Bch Parallel Connection, $V_{DD}=2.1V$, $I_O=400mA$	-	0.33	0.45	Ω
Parallel Connection Low Side Output ON Resistance 3	R_{PONL3}	Ach & Bch Parallel Connection, $V_{DD}=1.8V$, $I_O=400mA$	-	0.38	0.53	Ω
R_{ONH} Temperature Coefficient	$\Delta R_{ONH}/\Delta T_j$	$T_j=40\sim 125^{\circ}C$, $I_O=200mA$	-	4.0	-	m $\Omega/^{\circ}C$
R_{ONL} Temperature Coefficient	$\Delta R_{ONL}/\Delta T_j$	$T_j=40\sim 125^{\circ}C$, $I_O=200mA$	-	3.0	-	m $\Omega/^{\circ}C$
High Side Reverse Voltage	V_{ORH}	$I_O=-200mA$	-	0.85	1.0	V
Low Side Reverse Voltage	V_{ORL}	$I_O=-200mA$	-	0.75	0.9	V
High Side Leak Current	I_{OLEAKH}	$V_{DD}=7.0V$	-	-	1	μA
Low Side Leak Current	I_{OLEAKL}	$V_{DD}=7.0V$	-	-	1	μA
Output Turn ON Time	t_{ON}		200	400	600	ns
Output Turn OFF Time	t_{OFF}		5	40	80	ns
Dead Time	td		195	360	520	ns
■ COMPARATOR BLOCK						
Input Offset Voltage	V_{IO}		-12	-	+12	mV
Input Bias Current	I_{IB}		-	1	-	pA
Common Mode Input Voltage Range	V_{ICM}		0	-	$V_{DD}-0.5$	V
Output Voltage	V_{sat}	$R_L=10k\Omega$	-	0.1	-	V
Output Leak Current	I_{COLEAK}	$V_{CO}=5.5V$	-	-	1	μA

■ THERMAL RESISTANCE

● EQFN16-JE

PARAMETER	SYMBOL	TEST CONDITIONS	MIN.	TYP.	MAX.	UNIT
Junction - Ambient Thermal Resistance 1	θ_{ja_1}	Mounted on glass epoxy board based on EIA/JEDEC. (101.5×114.5×1.6mm, FR-4, 2Layers, connected exposed PAD)	-	-	173	°C/W
Junction - Case Surface Thermal Resistance 1	ψ_{jc_1}		-	21	-	°C/W
Junction - Ambient Thermal Resistance 2	θ_{ja_2}	Mounted on glass epoxy board based on EIA/JEDEC. (101.5×114.5×1.6mm, FR-4, 4Layers, Inner Cu area : 99.5×99.5mm, In addition thermal via holes, connected exposed PAD)	-	-	69	°C/W
Junction - Case Surface Thermal Resistance 2	ψ_{jc_2}		-	11	-	°C/W

● SSOP16

PARAMETER	SYMBOL	TEST CONDITIONS	MIN.	TYP.	MAX.	UNIT
Junction - Ambient Thermal Resistance 1	θ_{ja_1}	Mounted on glass epoxy board based on EIA/JEDEC. (76.2×114.3×1.6mm, FR-4, 2Layers)	-	-	204	°C/W
Junction - Case Surface Thermal Resistance 1	ψ_{jc_1}		-	35	-	°C/W
Junction - Ambient Thermal Resistance 2	θ_{ja_2}	Mounted on glass epoxy board based on EIA/JEDEC. (76.2×114.3×1.6mm, FR-4, 4Layers, Inner Cu area : 74.2×74.2mm)	-	-	160	°C/W
Junction - Case Surface Thermal Resistance 2	ψ_{jc_2}		-	26	-	°C/W

■ POWER DISSIPATION vs. AMBIENT TEMPERATURE

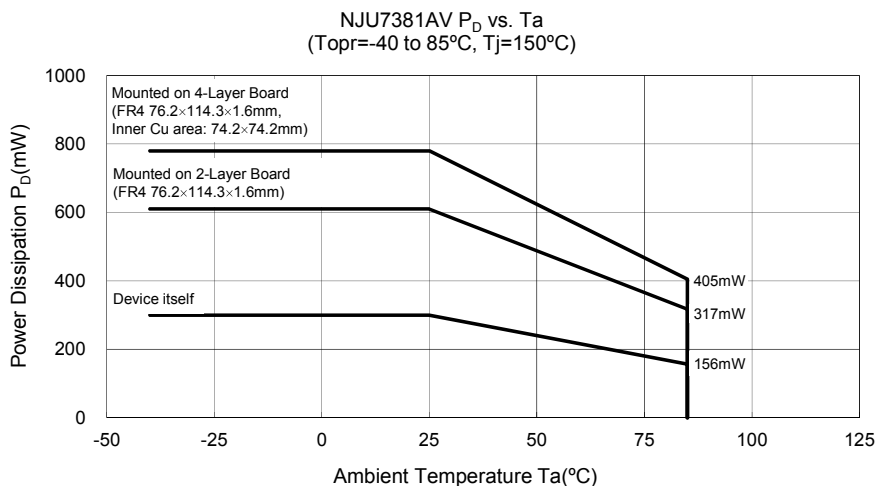
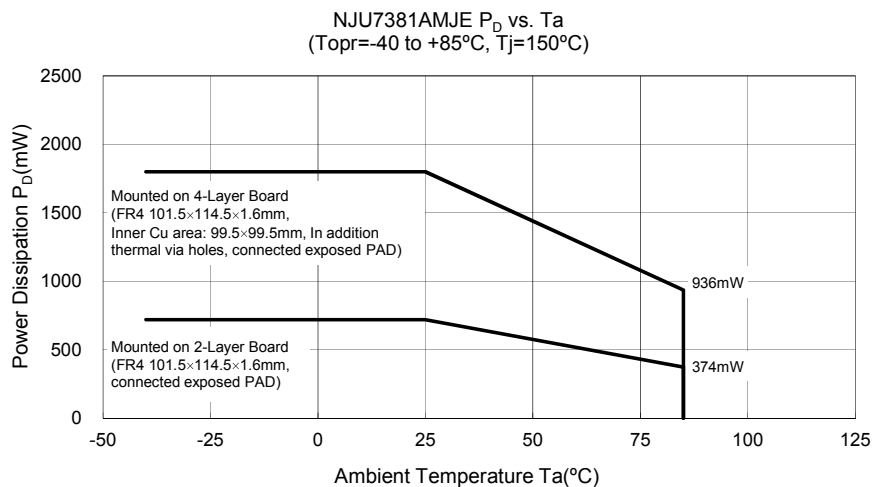

NJU7381A

INPUT - OUTPUT TRUTH TABLE

INPUT				OUTPUT				Comparator Circuit	NOTES	
INA1	INA2	INB1	INB2	OUTA1	OUTA2	OUTB1	OUTB2			
ALL L				OFF	OFF	OFF	OFF	STOP (Output OFF)	Standby	
L	L	-		OFF	OFF	-		Normal Operation	Ach	OFF(Fast Decay)
H	L			H	L					CW
L	H			L	H					CCW
H	H			H	H					Brake(Slow Decay)
-		L	L	OFF	OFF	Bch	OFF(Fast Decay)			
		H	L	H	L		CW			
		L	H	L	H		CCW			
		H	H	H	H		Brake(Slow Decay)			
Don't Care				OFF	OFF		OFF		OFF	TSD

*OFF=Hi-Z

COMPARATOR TRUTH TABLE (Normal Operation)

INPUT		OUTPUT	NOTES
COMP+	COMP-	COMPOUT	
H	L	OFF	FET: OFF Operation
L	H	L	FET: ON Operation

*OFF=Hi-Z

BASIC OPERATION TIMING CHART

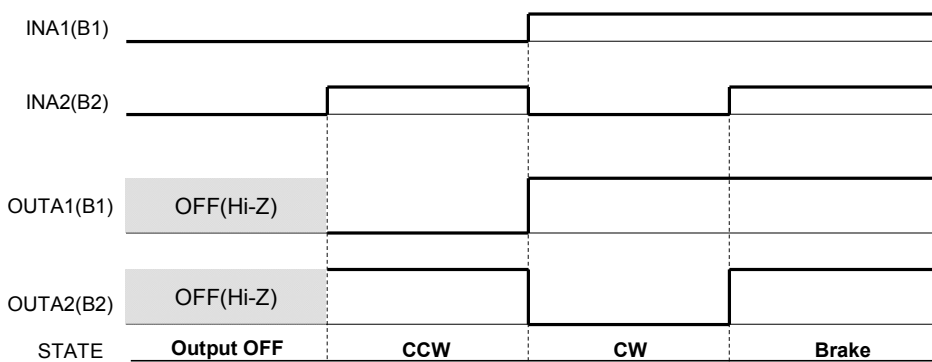

BASIC OUTPUT OPERATION PATTERN

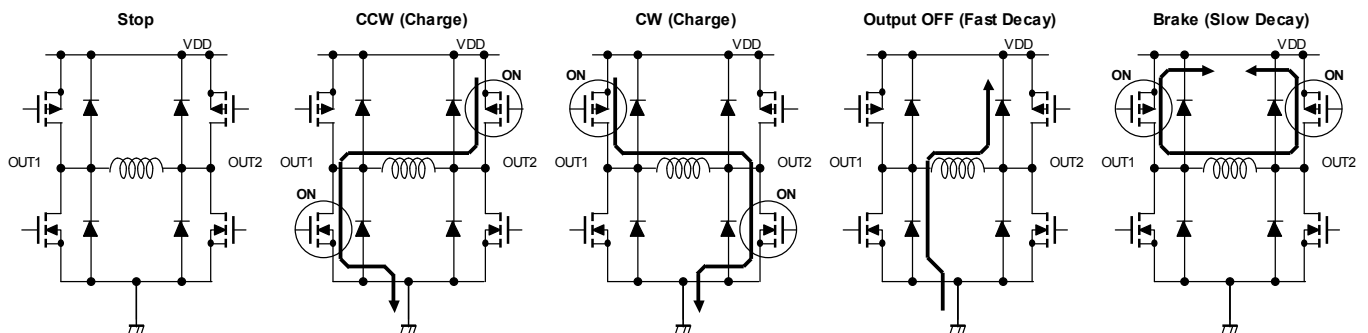

■ TYPICAL APPLICATIONS

• STANDARD

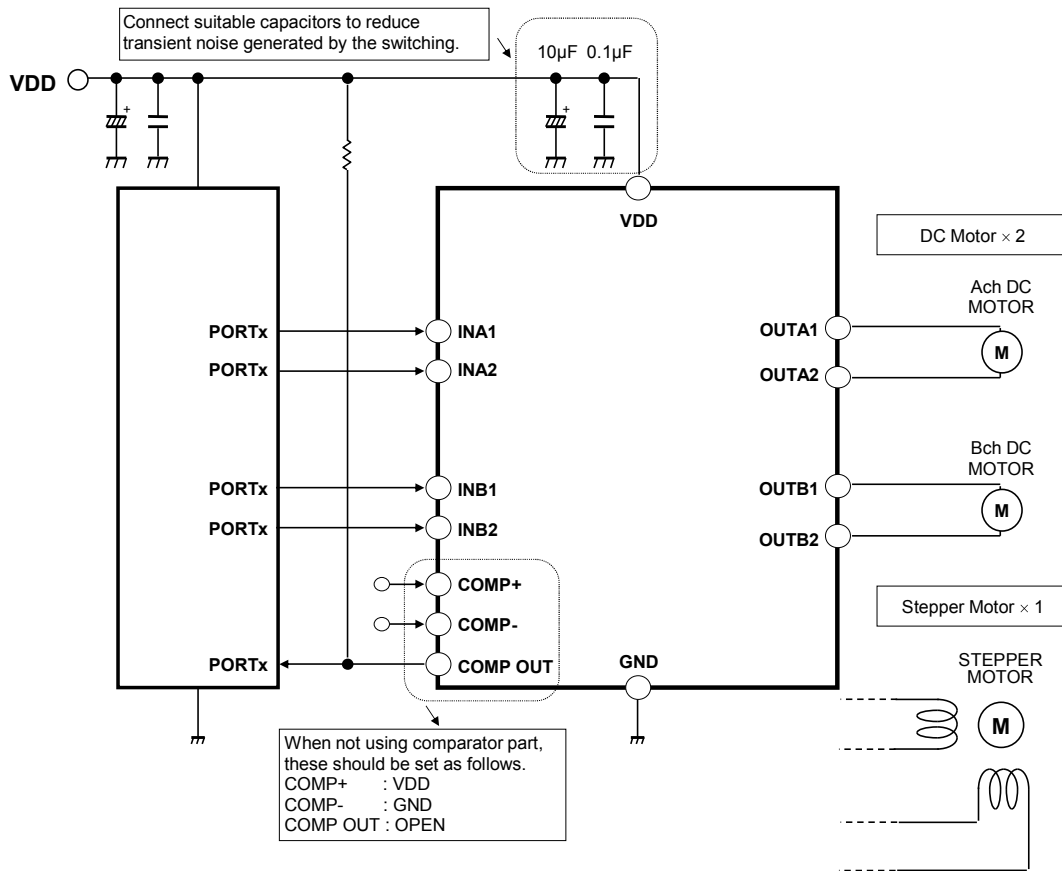

• PARALLEL CONNECTION (Boost Output Current)

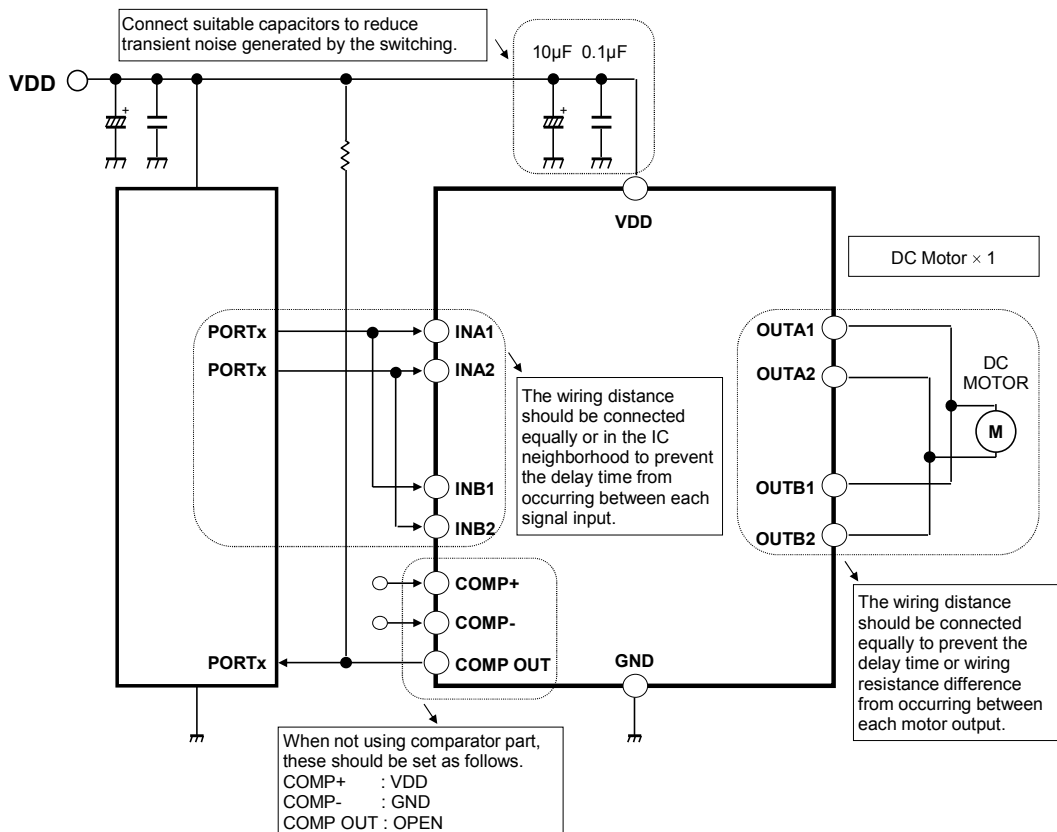

NJU7381A

■ STEPPER MOTOR DRIVE APPLICATION

• TIMING CHART

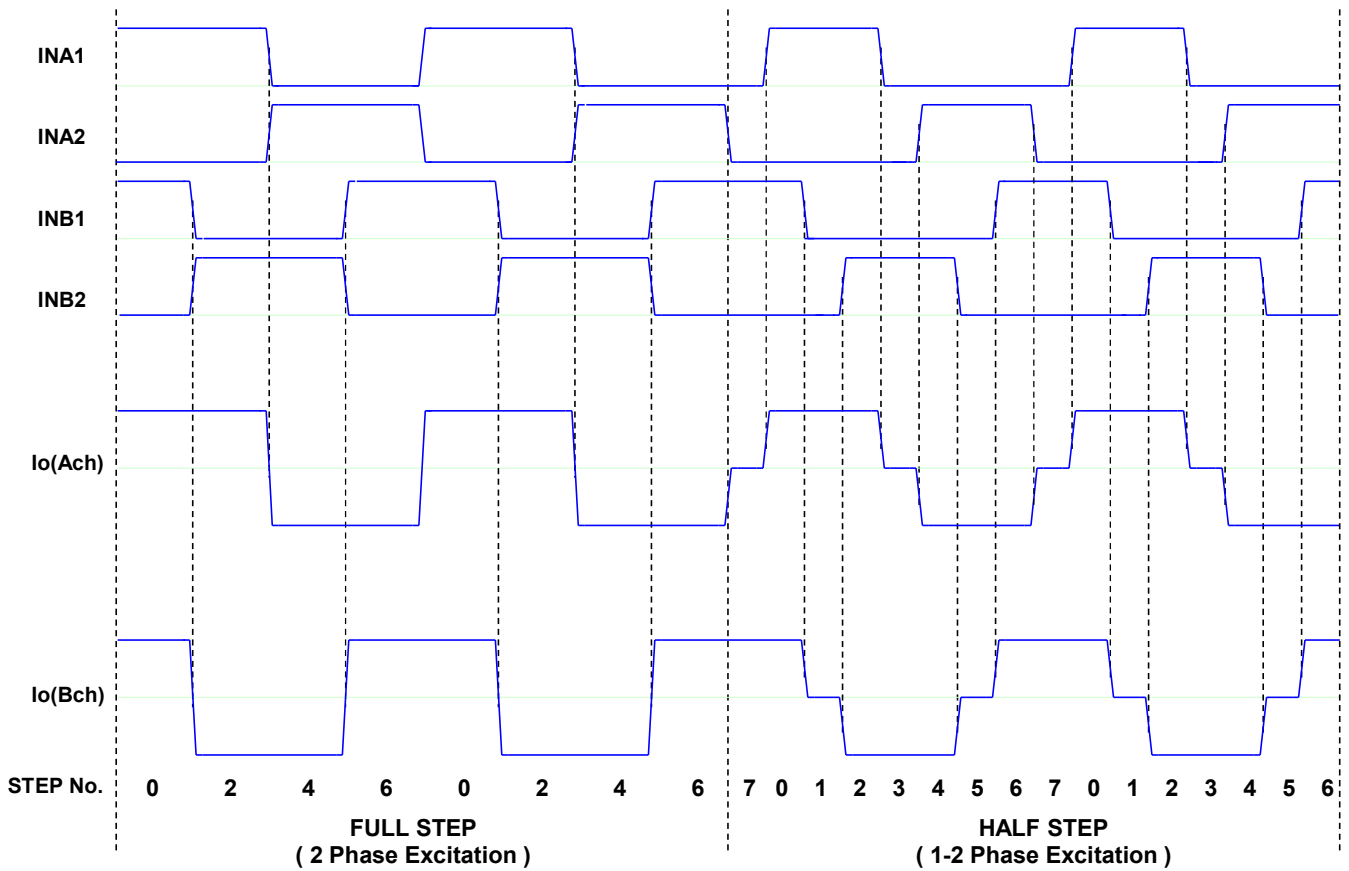

• ROTER POSITION (STEP No.)

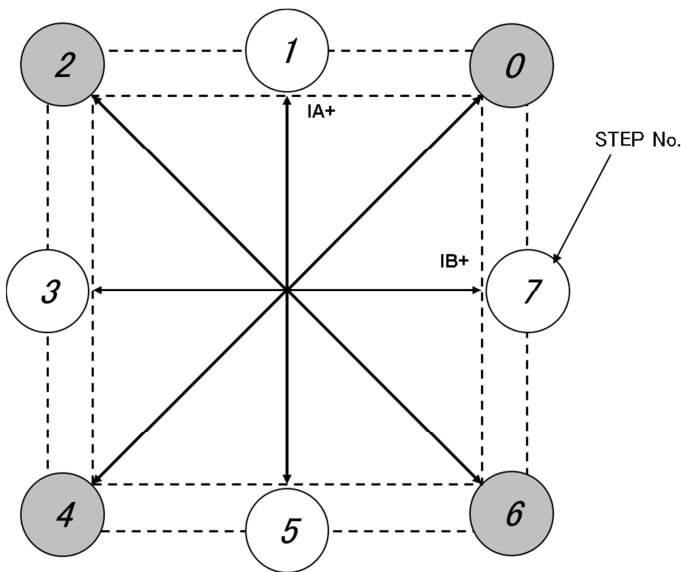

■ TYPICAL CHARACTERISTICS

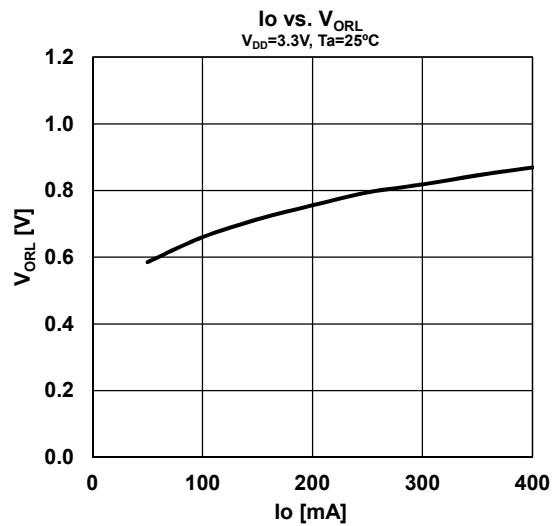
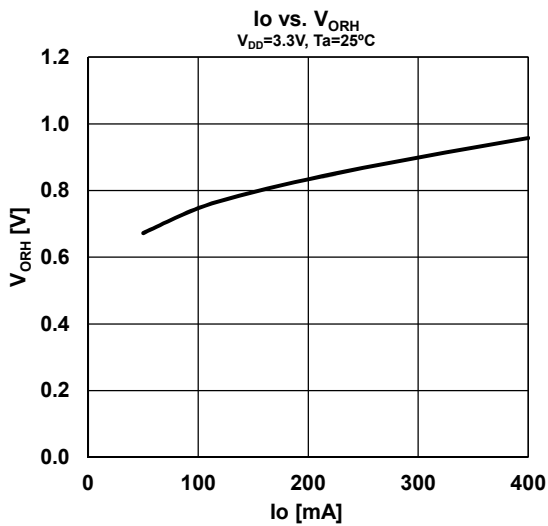
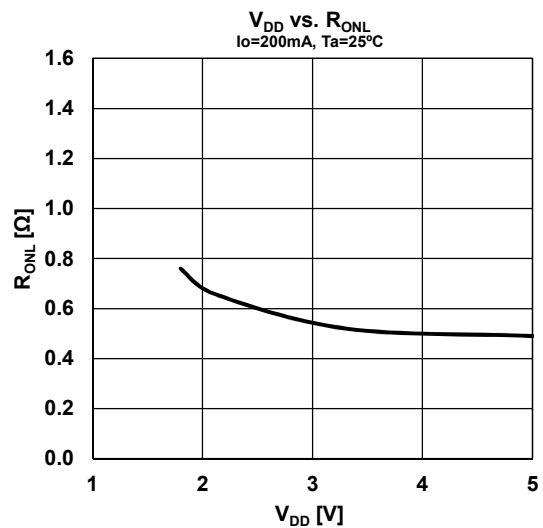
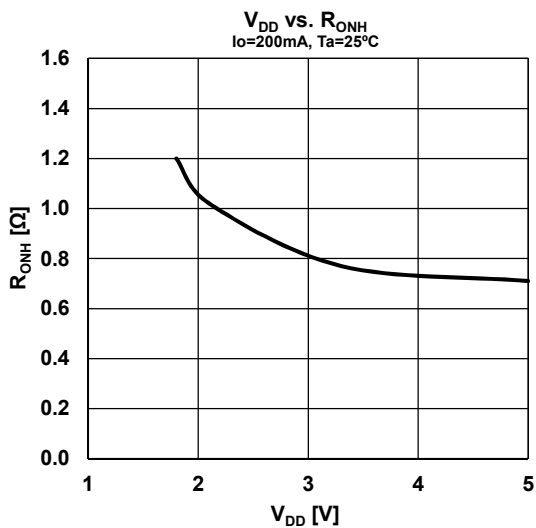
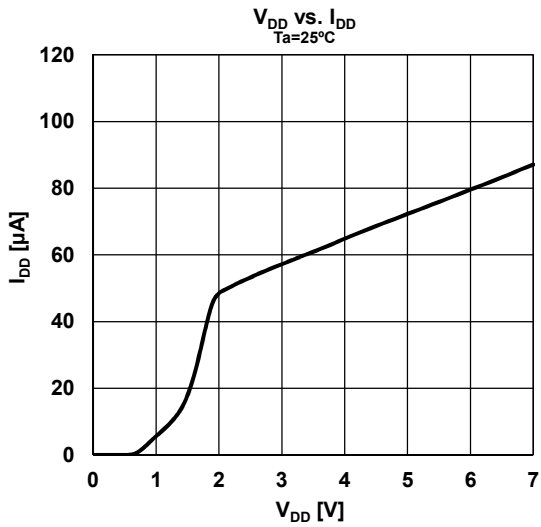

■ TYPICAL CHARACTERISTICS

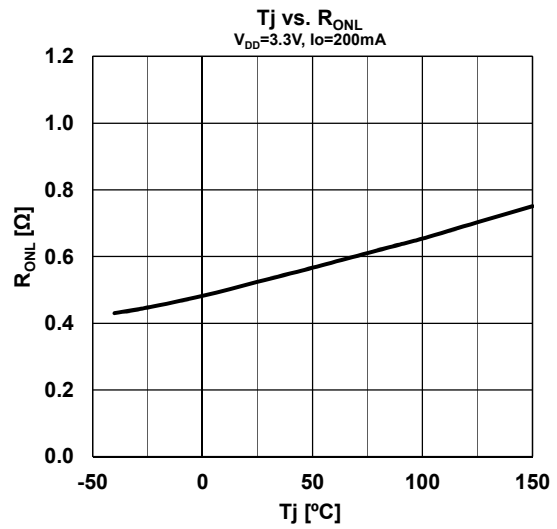
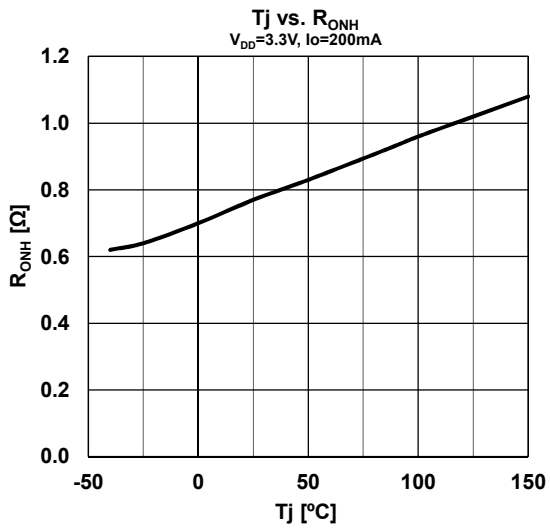
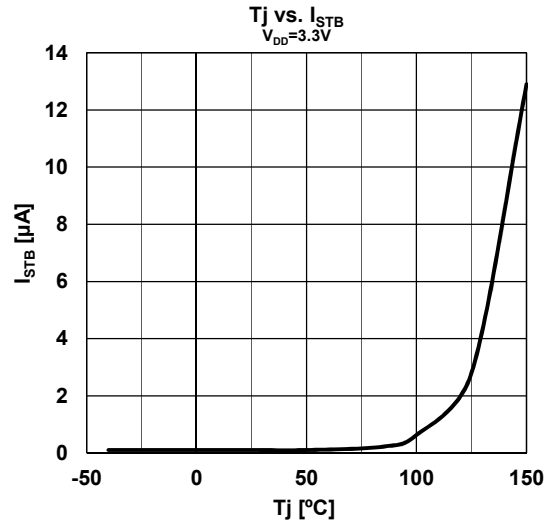
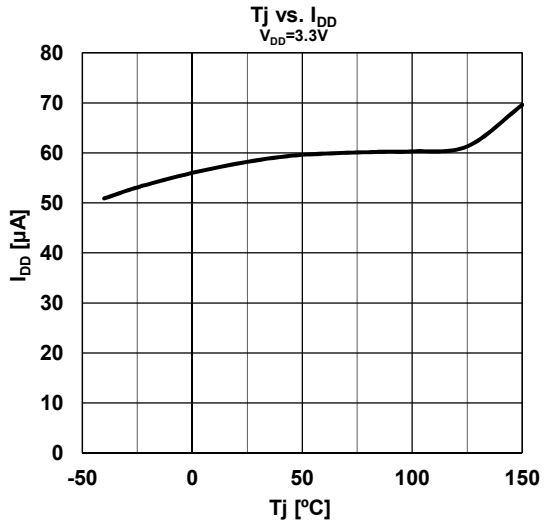

[CAUTION]

The specifications on this databook are only given for information, without any guarantee as regards either mistakes or omissions. The application circuits in this databook are described only to show representative usages of the product and not intended for the guarantee or permission of any right including the industrial rights.

Mouser Electronics

Authorized Distributor

Click to View Pricing, Inventory, Delivery & Lifecycle Information:

[NJR:](#)

[NJU7381AMJE-TE3](#) [NJU7381AV-TE1](#)

Данный компонент на территории Российской Федерации

Вы можете приобрести в компании MosChip.

Для оперативного оформления запроса Вам необходимо перейти по данной ссылке:

<http://moschip.ru/get-element>

Вы можете разместить у нас заказ для любого Вашего проекта, будь то серийное производство или разработка единичного прибора.

В нашем ассортименте представлены ведущие мировые производители активных и пассивных электронных компонентов.

Нашей специализацией является поставка электронной компонентной базы двойного назначения, продукции таких производителей как XILINX, Intel (ex.ALTERA), Vicor, Microchip, Texas Instruments, Analog Devices, Mini-Circuits, Amphenol, Glenair.

Сотрудничество с глобальными дистрибьюторами электронных компонентов, предоставляет возможность заказывать и получать с международных складов практически любой перечень компонентов в оптимальные для Вас сроки.

На всех этапах разработки и производства наши партнеры могут получить квалифицированную поддержку опытных инженеров.

Система менеджмента качества компании отвечает требованиям в соответствии с ГОСТ Р ИСО 9001, ГОСТ РВ 0015-002 и ЭС РД 009

Офис по работе с юридическими лицами:

105318, г.Москва, ул.Щербаковская д.3, офис 1107, 1118, ДЦ «Щербаковский»

Телефон: +7 495 668-12-70 (многоканальный)

Факс: +7 495 668-12-70 (доб.304)

E-mail: info@moschip.ru

Skype отдела продаж:

moschip.ru

moschip.ru_4

moschip.ru_6

moschip.ru_9