

Board-description: Demoboard 1x54W T5 - VM - 180VAC to 270VAC - ICB2FL03G

	Demoboard 1x54W T5
Design	Voltage Mode preheating
IC Type	ICB2FL03G

Name	short	rated value	unit	comment
Input voltage	V_{IN_AC}	230	V_{RMS}	180 V_{AC} to 270 V_{AC}
Input current	I_{IN}	257	mA_{RMS}	@230 V_{AC}
Input Power	P_{IN}	59,1	W	@230 V_{AC}
Power factor	PF	> 0,99		@230 V_{AC}
A_{THD}	Athd	< 4	%	@230 V_{AC}
efficiency		> 93	%	@230 V_{AC}
Bus voltage	V_{BUS}	410	V_{RMS}	Elko voltage
Preheating frequency	f_{PH}	106	kHz	
Run frequency	f_{RUN}	45,5	kHz	
preheating time	t_{PH}	1000	ms	
Lamp voltage	V_{Lamp}	118	V_{RMS}	
Lamp current	I_{Lamp}	460	mA_{RMS}	
Ignition voltage	V_{IGN}	> 620	V_{RMS}	
EOL1 threshold	V_{EOL1}	500	V_{PP}	Factor: 1,5 of V_{Lamp}
EOL2 threshold	P_{EOL2}	5	W	

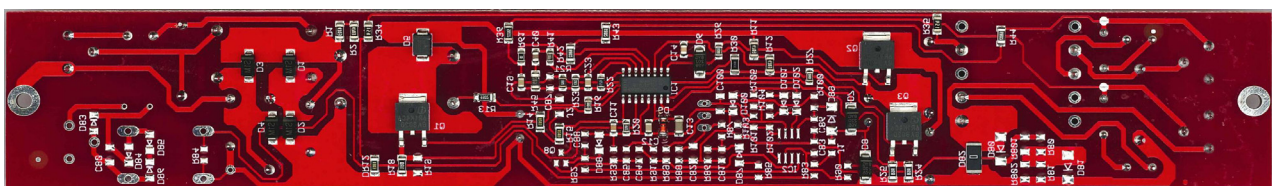

More information:

<http://www.infineon.com/smartlighting>

<http://www.infineon.com/CoolMOS>

Schematic: Demoboard 1x54W T5 - VM - 180VAC to 270VAC - ICB2FL03G

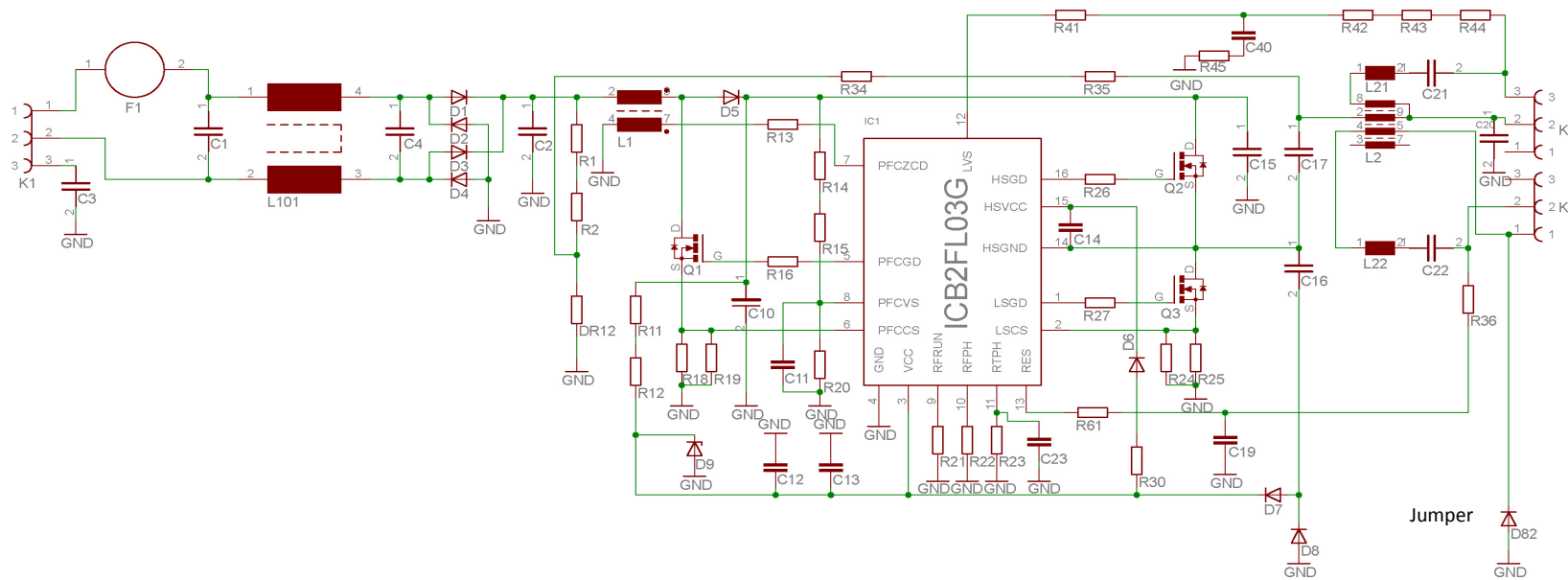

BOM: Demoboard 1x54W T5 - VM - 180VAC to 270VAC - ICB2FL03G

					ICB2FL03G	
Input voltage = 180VAC to 270VAC					VBUS = 410 VRMS	
Package					Package	
F1	Fuse 1A fast	Wickmann	Typ 370		R1	470kΩ .1206
K1/1	AC Input	WAGO 250-203			R2	470kΩ .1206
K1/2	AC Input					
K1/3	PE					
K2/1	not connected	WAGO 250-203			R11	470kΩ .1206
K2/2	High Side Filament					
K2/3	High Side Filament					
K3/1	Low Side Filament	WAGO 250-203			R12	470kΩ .1206
K3/2	Low Side Filament					
K3/3	not connected					
IC1	ICB2FL03G	Infineon		SO-16	R13	33kΩ .1206
Q1	IPD60R1k4C6	Infineon		D-Pack	R14	820kΩ .1206
Q2	IPD60R1k4C6	Infineon		D-Pack	R15	820kΩ .1206
Q3	IPD60R1k4C6	Infineon		D-Pack	R16	10Ω .0805
D1...4	S1M	Fairchild	(1000V/1A/2μs)	DO-214AC	R18	1Ω .1206
D5	MURS160T3	ON Semi	(600V/1A/75ns)	SMB	R19	not assembled .1206
D6	BYG20J	Philips	(600V/1,5A/75ns)	SOD124	R20	10kΩ .0805
D7	BYG22D	Philips	(200V/1A/25ns)	DO214	R21	11kΩ .0805
D8	BYG22D	Philips	(200V/1A/25ns)	DO214	R22	8.2kΩ .0805
D9	BZV55-C16	NXP		SOD-80C	R23	10kΩ .0805
DR12	110kΩ				R24	0.68Ω .1206
D82	0Ω				R25	0.68Ω .1206
L101	2x68mH/0.6A	Epcos	B82732F2601B001		R26	10Ω .0805
L1 PFC	1.58mH	Wuerth	750315271	EFD25/13/9	R27	10Ω .0805
L 2	1.46mH	Wuerth	750315259	EFD25/13/9	R30	33Ω .1206
L 21	100μH/760mA	Epcos	B82144B1104J000	RM5	R34	150kΩ .1206
L 22	100μH/760mA	Epcos	B82144B1104J000	RM5	R35	150kΩ .1206
C1	220nF/X2/305V	Epcos	B32922C3224M000	RM15	R36	56kΩ .1206
C2	33nF/630V/MKT	Epcos	B32521N8333K000	RM10	R41	68kΩ .0805
C3	3,3nF/Y2/300V	Epcos	B32021A3332K000	RM10	R42	68kΩ .1206
C4	220nF/X2/305V	Epcos	B32922C3224M000	RM15	R43	68kΩ .1206
C10	10μF/450V	Epcos	B43888C5106M000	single ended	R44	68kΩ .1206
C11	2,2nF/50V	X7R		.0805	R45	6,8kΩ .1206
C12	100nF/50V	X7R		.0805	R61	0Ω .0805
C13	1μF/25V	X7R		.1206		
C14	68nF/50V	X7R		.0805		
C15	22nF/630V/MKT	Epcos	B32621A6223K000	RM10		
C16	1nF/630V/MKT	Epcos	B32529C8102K000	RM5		
C17	100nF/630V/MKP	Epcos	B32612A6104K008	RM15		
C19	22nF/50V	X7R		.0805		
C20	4,7nF/1600V/MKP	Epcos	B32612-J1472J008	RM15		
C21	22nF/400V/MKP	Epcos	B32620A4223J000	RM7,5		
C22	22nF/400V/MKP	Epcos	B32620A4223J000	RM7,5		
C23	10nF/50V	X7R		.0805		
C40	220nF/50V	X7R		.0805		

More information:
<http://www.infineon.com/smartlighting>
<http://www.infineon.com/CoolMOS>

L-Design - Inverter: Demoboard 1x54W T5 - VM - 180VAC to 270VAC - ICB2FL03G

Coil former					Ordering code
Sections	A_N mm ²	l_N mm	A_R value $\mu\Omega$	Pins	
1	40,7	50	42,3	10	B66422-B1010-D1 B66422-W1010-D1
Yoke (ordering code per piece, 2 are required)					B66422-B2000

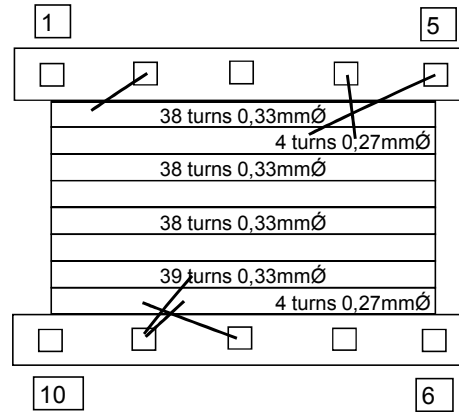
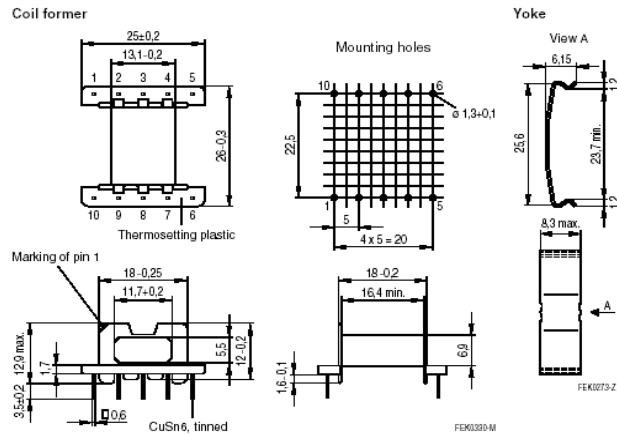

EFD 25/13/9; N87; (total gap= 2,0mm)
L=1,46mH
View at pin-side of the coil former

Wind windings (Pin 2 to Pin 9) first
then the others for preheating on top

Wuerth Part # 750315259

L-Design - PFC: Demoboard 1x54W T5 - VM - 180VAC to 270VAC - ICB2FL03G

Coil former					Ordering code
Sections	A_N mm ²	l_N mm	A_R value $\mu\Omega$	Pins	
1	40,7	50	42,3	10	B66422-B1010-D1 B66422-W1010-D1
Yoke (ordering code per piece, 2 are required)					B66422-B2000

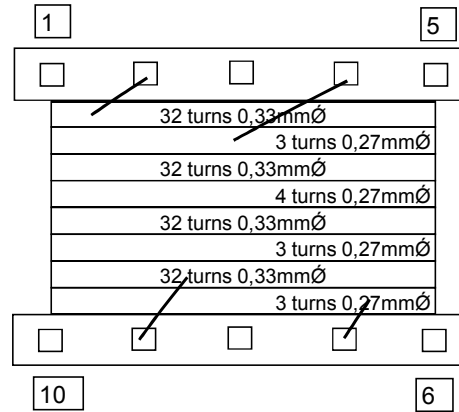
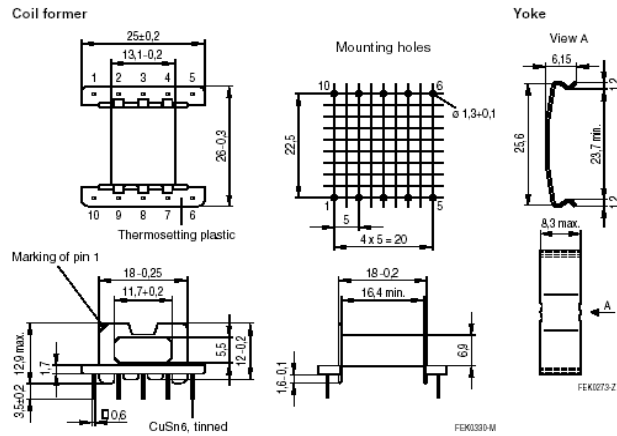

EFD 25/13/9; N87; (total gap= 1,1mm)
L=1,58mH
View at pin-side of the coil former

Wind windings (Pin 2 to Pin 9) first
then the others on top

Wuerth Part # 750315271

Данный компонент на территории Российской Федерации

Вы можете приобрести в компании MosChip.

Для оперативного оформления запроса Вам необходимо перейти по данной ссылке:

<http://moschip.ru/get-element>

Вы можете разместить у нас заказ для любого Вашего проекта, будь то серийное производство или разработка единичного прибора.

В нашем ассортименте представлены ведущие мировые производители активных и пассивных электронных компонентов.

Нашей специализацией является поставка электронной компонентной базы двойного назначения, продукции таких производителей как XILINX, Intel (ex.ALTERA), Vicor, Microchip, Texas Instruments, Analog Devices, Mini-Circuits, Amphenol, Glenair.

Сотрудничество с глобальными дистрибьюторами электронных компонентов, предоставляет возможность заказывать и получать с международных складов практически любой перечень компонентов в оптимальные для Вас сроки.

На всех этапах разработки и производства наши партнеры могут получить квалифицированную поддержку опытных инженеров.

Система менеджмента качества компании отвечает требованиям в соответствии с ГОСТ Р ИСО 9001, ГОСТ РВ 0015-002 и ЭС РД 009

Офис по работе с юридическими лицами:

105318, г.Москва, ул.Щербаковская д.3, офис 1107, 1118, ДЦ «Щербаковский»

Телефон: +7 495 668-12-70 (многоканальный)

Факс: +7 495 668-12-70 (доб.304)

E-mail: info@moschip.ru

Skype отдела продаж:

moschip.ru

moschip.ru_4

moschip.ru_6

moschip.ru_9