

## FEATURES

- 700MHz min. operating frequency
- Extended 100E VEE range of -4.2V to -5.5V
- 9 bits wide for byte-parity applications
- Asynchronous Master Reset
- Dual clocks
- Fully compatible with industry standard 10KH, 100K ECL levels
- Internal 75kΩ input pulldown resistors
- Fully compatible with Motorola MC10E/100E143
- Available in 28-pin PLCC package

## BLOCK DIAGRAM

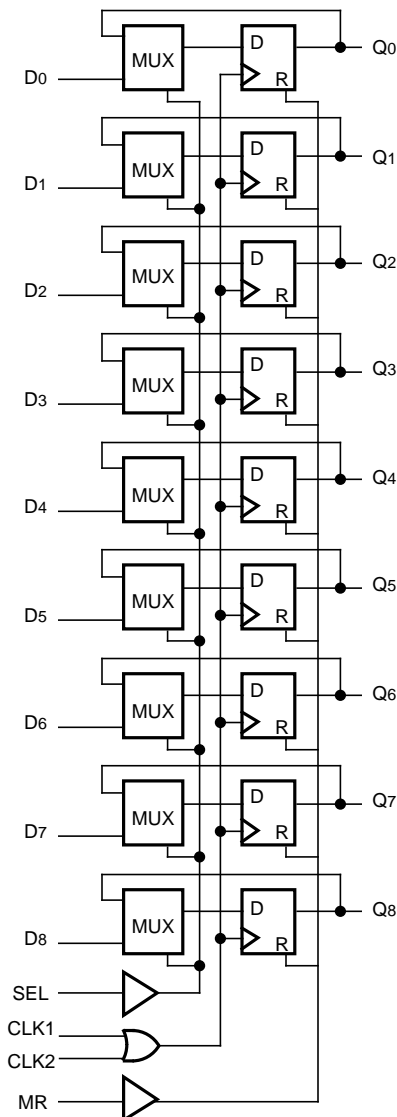

## DESCRIPTION

The SY10/100E143 are high-speed 9-bit hold registers designed for use in new, high-performance ECL systems. The E143 can hold current data or load new data. The nine inputs, D<sub>0</sub>-D<sub>8</sub>, accept parallel input data.

The SEL (Select) control pin serves to determine the mode of operation; either HOLD or LOAD. The input data has to meet the set-up time before being clocked into the nine input registers on the rising edge of CLK<sub>1</sub> or CLK<sub>2</sub>. The MR (Master Reset) control signal asynchronously resets all nine registers to a logic LOW when a logic HIGH is applied to MR.

The E143 is designed for applications requiring high-speed registers, pipeline registers, synchronous operation, and is also suitable for byte-wide parity.

## PIN NAMES

Pin	Function
D <sub>0</sub> -D <sub>8</sub>	Parallel Data Inputs
SEL	Mode Select Input
CLK <sub>1</sub> , CLK <sub>2</sub>	Clock Inputs
MR	Master Reset
Q <sub>0</sub> -Q <sub>8</sub>	Data Outputs
NC	No Connection
V <sub>CCO</sub>	V <sub>CC</sub> to Output

**PACKAGE/ORDERING INFORMATION**

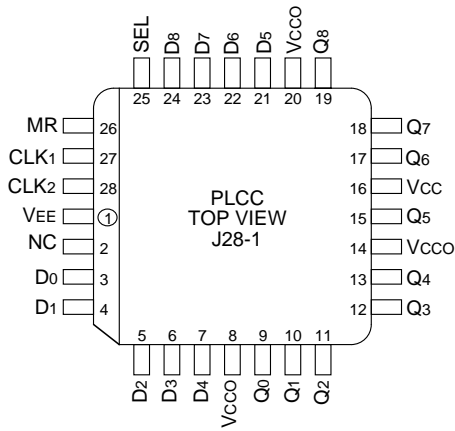

**28-Pin PLCC (J28-1)**

**Ordering Information<sup>(1)</sup>**

Part Number	Package Type	Operating Range	Package Marking	Lead Finish
SY10E143JC	J28-1	Commercial	SY10E143JC	Sn-Pb
SY10E143JCTR <sup>(2)</sup>	J28-1	Commercial	SY10E143JC	Sn-Pb
SY100E143JC	J28-1	Commercial	SY100E143JC	Sn-Pb
SY100E143JCTR <sup>(2)</sup>	J28-1	Commercial	SY100E143JC	Sn-Pb
SY10E143JZ <sup>(3)</sup>	J28-1	Commercial	SY10E143JZ with Pb-Free bar-line indicator	Matte-Sn
SY10E143JZTR <sup>(2, 3)</sup>	J28-1	Commercial	SY10E143JZ with Pb-Free bar-line indicator	Matte-Sn
SY100E143JZ <sup>(3)</sup>	J28-1	Commercial	SY100E143JZ with Pb-Free bar-line indicator	Matte-Sn
SY100E143JZTR <sup>(2, 3)</sup>	J28-1	Commercial	SY100E143JZ with Pb-Free bar-line indicator	Matte-Sn

**Notes:**

1. Contact factory for die availability. Dice are guaranteed at T<sub>A</sub> = 25°C, DC Electricals only.
2. Tape and Reel.
3. Pb-Free package is recommended for new designs.

**TRUTH TABLE**

SEL	MODE
L	LOAD
H	HOLD

**DC ELECTRICAL CHARACTERISTICS**

VEE = VEE (Min.) to VEE (Max.); VCC = VCCO = GND

Symbol	Parameter	TA = 0°C			TA = +25°C			TA = +85°C			Unit	Condition	
		Min.	Typ.	Max.	Min.	Typ.	Max.	Min.	Typ.	Max.			
I <sub>IH</sub>	Input HIGH Current	—	—	150	—	—	150	—	—	150	μA	—	
I <sub>EE</sub>	Power Supply Current	10E	—	120	145	—	120	145	—	120	145	mA	—
		100E	—	120	145	—	120	145	—	138	165		

**AC ELECTRICAL CHARACTERISTICS**

VEE = VEE (Min.) to VEE (Max.); VCC = VCCO = GND

Symbol	Parameter	TA = 0°C			TA = +25°C			TA = +85°C			Unit	Condition
		Min.	Typ.	Max.	Min.	Typ.	Max.	Min.	Typ.	Max.		
f <sub>MAX</sub>	Max. Toggle Frequency	700	900	—	700	900	—	700	900	—	MHz	—
t <sub>PD</sub>	Propagation Delay to Output CLK MR	600	800	1000	600	800	1000	600	800	1000	ps	—
		600	800	1000	600	800	1000	600	800	1000		
t <sub>S</sub>	Set-up Time D SEL	50	-100	—	50	-100	—	50	-100	—	ps	—
		300	150	—	300	150	—	300	150	—		
t <sub>H</sub>	Hold Time D SEL	300	100	—	300	100	—	300	100	—	ps	—
		75	-150	—	75	-150	—	75	-150	—		
t <sub>RR</sub>	Reset Recovery Time	900	700	—	900	700	—	900	700	—	ps	—
t <sub>PW</sub>	Minimum Pulse Width CLK, MR	400	—	—	400	—	—	400	—	—	ps	—
t <sub>skew</sub>	Within-Device Skew	—	75	—	—	75	—	—	75	—	ps	1
t <sub>r</sub> t <sub>f</sub>	Rise/Fall Time 20% to 80%	300	525	800	300	525	800	300	525	800	ps	—

**Note:**

1. Within-device skew is defined as identical transitions on similar paths through a device.

**28-PIN PLCC (J28-1)**



Rev. 03

**MICREL, INC. 2180 FORTUNE DRIVE SAN JOSE, CA 95131 USA**

TEL + 1 (408) 944-0800 FAX + 1 (408) 474-1000 WEB <http://www.micrel.com>

The information furnished by Micrel in this data sheet is believed to be accurate and reliable. However, no responsibility is assumed by Micrel for its use. Micrel reserves the right to change circuitry and specifications at any time without notification to the customer.

Micrel Products are not designed or authorized for use as components in life support appliances, devices or systems where malfunction of a product can reasonably be expected to result in personal injury. Life support devices or systems are devices or systems that (a) are intended for surgical implant into the body or (b) support or sustain life, and whose failure to perform can be reasonably expected to result in a significant injury to the user. A Purchaser's use or sale of Micrel Products for use in life support appliances, devices or systems is at Purchaser's own risk and Purchaser agrees to fully indemnify Micrel for any damages resulting from such use or sale.

© 2006 Micrel, Incorporated.

## Данный компонент на территории Российской Федерации

### Вы можете приобрести в компании MosChip.

Для оперативного оформления запроса Вам необходимо перейти по данной ссылке:

<http://moschip.ru/get-element>

Вы можете разместить у нас заказ для любого Вашего проекта, будь то серийное производство или разработка единичного прибора.

В нашем ассортименте представлены ведущие мировые производители активных и пассивных электронных компонентов.

Нашей специализацией является поставка электронной компонентной базы двойного назначения, продукции таких производителей как XILINX, Intel (ex.ALTERA), Vicor, Microchip, Texas Instruments, Analog Devices, Mini-Circuits, Amphenol, Glenair.

Сотрудничество с глобальными дистрибьюторами электронных компонентов, предоставляет возможность заказывать и получать с международных складов практически любой перечень компонентов в оптимальные для Вас сроки.

На всех этапах разработки и производства наши партнеры могут получить квалифицированную поддержку опытных инженеров.

Система менеджмента качества компании отвечает требованиям в соответствии с ГОСТ Р ИСО 9001, ГОСТ РВ 0015-002 и ЭС РД 009

### Офис по работе с юридическими лицами:

105318, г.Москва, ул.Щербаковская д.3, офис 1107, 1118, ДЦ «Щербаковский»

Телефон: +7 495 668-12-70 (многоканальный)

Факс: +7 495 668-12-70 (доб.304)

E-mail: [info@moschip.ru](mailto:info@moschip.ru)

Skype отдела продаж:

moschip.ru

moschip.ru\_4

moschip.ru\_6

moschip.ru\_9