

***TPA2008D2 Stereo  
Filter-Free Class-D  
Audio Power Amplifier  
Evaluation Module***

*User's Guide*

## IMPORTANT NOTICE

Texas Instruments Incorporated and its subsidiaries (TI) reserve the right to make corrections, modifications, enhancements, improvements, and other changes to its products and services at any time and to discontinue any product or service without notice. Customers should obtain the latest relevant information before placing orders and should verify that such information is current and complete. All products are sold subject to TI's terms and conditions of sale supplied at the time of order acknowledgment.

TI warrants performance of its hardware products to the specifications applicable at the time of sale in accordance with TI's standard warranty. Testing and other quality control techniques are used to the extent TI deems necessary to support this warranty. Except where mandated by government requirements, testing of all parameters of each product is not necessarily performed.

TI assumes no liability for applications assistance or customer product design. Customers are responsible for their products and applications using TI components. To minimize the risks associated with customer products and applications, customers should provide adequate design and operating safeguards.

TI does not warrant or represent that any license, either express or implied, is granted under any TI patent right, copyright, mask work right, or other TI intellectual property right relating to any combination, machine, or process in which TI products or services are used. Information published by TI regarding third-party products or services does not constitute a license from TI to use such products or services or a warranty or endorsement thereof. Use of such information may require a license from a third party under the patents or other intellectual property of the third party, or a license from TI under the patents or other intellectual property of TI.

Reproduction of information in TI data books or data sheets is permissible only if reproduction is without alteration and is accompanied by all associated warranties, conditions, limitations, and notices. Reproduction of this information with alteration is an unfair and deceptive business practice. TI is not responsible or liable for such altered documentation.

Resale of TI products or services with statements different from or beyond the parameters stated by TI for that product or service voids all express and any implied warranties for the associated TI product or service and is an unfair and deceptive business practice. TI is not responsible or liable for any such statements.

Following are URLs where you can obtain information on other Texas Instruments products and application solutions:

<b>Products</b>		<b>Applications</b>	
Amplifiers	<a href="http://amplifier.ti.com">amplifier.ti.com</a>	Audio	<a href="http://www.ti.com/audio">www.ti.com/audio</a>
Data Converters	<a href="http://dataconverter.ti.com">dataconverter.ti.com</a>	Automotive	<a href="http://www.ti.com/automotive">www.ti.com/automotive</a>
DSP	<a href="http://dsp.ti.com">dsp.ti.com</a>	Broadband	<a href="http://www.ti.com/broadband">www.ti.com/broadband</a>
Interface	<a href="http://interface.ti.com">interface.ti.com</a>	Digital Control	<a href="http://www.ti.com/digitalcontrol">www.ti.com/digitalcontrol</a>
Logic	<a href="http://logic.ti.com">logic.ti.com</a>	Military	<a href="http://www.ti.com/military">www.ti.com/military</a>
Power Mgmt	<a href="http://power.ti.com">power.ti.com</a>	Optical Networking	<a href="http://www.ti.com/opticalnetwork">www.ti.com/opticalnetwork</a>
Microcontrollers	<a href="http://microcontroller.ti.com">microcontroller.ti.com</a>	Security	<a href="http://www.ti.com/security">www.ti.com/security</a>
		Telephony	<a href="http://www.ti.com/telephony">www.ti.com/telephony</a>
		Video & Imaging	<a href="http://www.ti.com/video">www.ti.com/video</a>
		Wireless	<a href="http://www.ti.com/wireless">www.ti.com/wireless</a>

Mailing Address: Texas Instruments  
Post Office Box 655303 Dallas, Texas 75265

## EVM IMPORTANT NOTICE

Texas Instruments (TI) provides the enclosed product(s) under the following conditions:

This evaluation kit being sold by TI is intended for use for **ENGINEERING DEVELOPMENT OR EVALUATION PURPOSES ONLY** and is not considered by TI to be fit for commercial use. As such, the goods being provided may not be complete in terms of required design-, marketing-, and/or manufacturing-related protective considerations, including product safety measures typically found in the end product incorporating the goods. As a prototype, this product does not fall within the scope of the European Union directive on electromagnetic compatibility and therefore may not meet the technical requirements of the directive.

Should this evaluation kit not meet the specifications indicated in the EVM User's Guide, the kit may be returned within 30 days from the date of delivery for a full refund. **THE FOREGOING WARRANTY IS THE EXCLUSIVE WARRANTY MADE BY SELLER TO BUYER AND IS IN LIEU OF ALL OTHER WARRANTIES, EXPRESSED, IMPLIED, OR STATUTORY, INCLUDING ANY WARRANTY OF MERCHANTABILITY OR FITNESS FOR ANY PARTICULAR PURPOSE.**

The user assumes all responsibility and liability for proper and safe handling of the goods. Further, the user indemnifies TI from all claims arising from the handling or use of the goods. Please be aware that the products received may not be regulatory compliant or agency certified (FCC, UL, CE, etc.). Due to the open construction of the product, it is the user's responsibility to take any and all appropriate precautions with regard to electrostatic discharge.

**EXCEPT TO THE EXTENT OF THE INDEMNITY SET FORTH ABOVE, NEITHER PARTY SHALL BE LIABLE TO THE OTHER FOR ANY INDIRECT, SPECIAL, INCIDENTAL, OR CONSEQUENTIAL DAMAGES.**

TI currently deals with a variety of customers for products, and therefore our arrangement with the user **is not exclusive**.

TI assumes **no liability for applications assistance, customer product design, software performance, or infringement of patents or services described herein**.

Please read the EVM User's Guide and, specifically, the EVM Warnings and Restrictions notice in the EVM User's Guide prior to handling the product. This notice contains important safety information about temperatures and voltages. For further safety concerns, please contact the TI application engineer.

Persons handling the product must have electronics training and observe good laboratory practice standards.

No license is granted under any patent right or other intellectual property right of TI covering or relating to any machine, process, or combination in which such TI products or services might be or are used.

Mailing Address:

Texas Instruments  
Post Office Box 655303  
Dallas, Texas 75265

## EVM IMPORTANT NOTICE

Texas Instruments (TI) provides the enclosed product(s) under the following conditions:

This evaluation kit being sold by TI is intended for use for **ENGINEERING DEVELOPMENT OR EVALUATION PURPOSES ONLY** and is not considered by TI to be fit for commercial use. As such, the goods being provided may not be complete in terms of required design-, marketing-, and/or manufacturing-related protective considerations, including product safety measures typically found in the end product incorporating the goods. As a prototype, this product does not fall within the scope of the European Union directive on electromagnetic compatibility and therefore may not meet the technical requirements of the directive.

Should this evaluation kit not meet the specifications indicated in the EVM User's Guide, the kit may be returned within 30 days from the date of delivery for a full refund. **THE FOREGOING WARRANTY IS THE EXCLUSIVE WARRANTY MADE BY SELLER TO BUYER AND IS IN LIEU OF ALL OTHER WARRANTIES, EXPRESSED, IMPLIED, OR STATUTORY, INCLUDING ANY WARRANTY OF MERCHANTABILITY OR FITNESS FOR ANY PARTICULAR PURPOSE.**

The user assumes all responsibility and liability for proper and safe handling of the goods. Further, the user indemnifies TI from all claims arising from the handling or use of the goods. Please be aware that the products received may not be regulatory compliant or agency certified (FCC, UL, CE, etc.). Due to the open construction of the product, it is the user's responsibility to take any and all appropriate precautions with regard to electrostatic discharge.

**EXCEPT TO THE EXTENT OF THE INDEMNITY SET FORTH ABOVE, NEITHER PARTY SHALL BE LIABLE TO THE OTHER FOR ANY INDIRECT, SPECIAL, INCIDENTAL, OR CONSEQUENTIAL DAMAGES.**

TI currently deals with a variety of customers for products, and therefore our arrangement with the user **is not exclusive**.

TI assumes **no liability for applications assistance, customer product design, software performance, or infringement of patents or services described herein**.

Please read the EVM User's Guide and, specifically, the EVM Warnings and Restrictions notice in the EVM User's Guide prior to handling the product. This notice contains important safety information about temperatures and voltages. For further safety concerns, please contact the TI application engineer.

Persons handling the product must have electronics training and observe good laboratory practice standards.

No license is granted under any patent right or other intellectual property right of TI covering or relating to any machine, process, or combination in which such TI products or services might be or are used.

Mailing Address:

Texas Instruments  
Post Office Box 655303  
Dallas, Texas 75265

---

## EVM WARNINGS AND RESTRICTIONS

It is important to operate this EVM within the supply voltage range specified in the user's guide. The supply voltage range should be 4.5 V to 5.5 V.

Exceeding the specified input range may cause unexpected operation and/or irreversible damage to the EVM. If there are questions concerning the input range, please contact a TI field representative prior to connecting the input power.

Applying loads outside of the specified output range may result in unintended operation and/or possible permanent damage to the EVM. Please consult the EVM User's Guide prior to connecting any load to the EVM output. If there is uncertainty as to the load specification, please contact a TI field representative.

During normal operation, some circuit components may have case temperatures greater than 85°C. The EVM is designed to operate properly with certain components above 85°C as long as the input and output ranges are maintained. These components include but are not limited to linear regulators, switching transistors, pass transistors, and current sense resistors. These types of devices can be identified using the EVM schematic located in the EVM User's Guide. When placing measurement probes near these devices during operation, please be aware that these devices may be very warm to the touch.

Mailing Address:

Texas Instruments  
Post Office Box 655303  
Dallas, Texas 75265

Copyright © 2004, Texas Instruments Incorporated

# Preface

---

---

---

---

## ***How to Use This Manual***

This document contains the following chapters:

- Chapter 1—Introduction
- Chapter 2—Operation
- Chapter 3—Reference

## ***Information About Cautions and Warnings***

This book may contain cautions and warnings.

**This is an example of a caution statement.**  
**A caution statement describes a situation that could potentially damage your software or equipment.**

**This is an example of a warning statement.**  
**A warning statement describes a situation that could potentially cause harm to you.**

The information in a caution or a warning is provided for your protection. Please read each caution and warning carefully.

### **Related Documentation From Texas Instruments**

- **TI Plug-N-Play Audio Amplifier Evaluation Platform** (literature number SLOU011) provides detailed information on the evaluation platform and its use with TI audio evaluation modules.
  
- **TPA2008D2 3-W STEREO CLASS-D AUDIO POWER AMPLIFIER** (literature number SLOS413) This is the data sheet for the TPA2008D2 audio amplifier integrated circuit.

### **FCC Warning**

This equipment is intended for use in a laboratory test environment only. It generates, uses, and can radiate radio frequency energy and has not been tested for compliance with the limits of computing devices pursuant to subpart J of part 15 of FCC rules, which are designed to provide reasonable protection against radio frequency interference. Operation of this equipment in other environments may cause interference with radio communications, in which case the user at his own expense will be required to take whatever measures may be required to correct this interference.

# Contents

---

---

---

<b>1</b>	<b>Introduction</b> .....	<b>1-1</b>
1.1	Feature Highlights .....	1-2
1.2	Description .....	1-3
1.3	TPA2008D2 EVM Specifications .....	1-4
<b>2</b>	<b>Operation</b> .....	<b>2-1</b>
2.1	Precautions .....	2-2
2.2	Quick Start List for Platform .....	2-3
2.3	Quick Start List for Stand-Alone .....	2-4
2.4	Power Requirements .....	2-6
<b>3</b>	<b>Reference</b> .....	<b>3-1</b>
3.1	TPA2008D2 EVM Schematic .....	3-2
3.2	TPA2008D2 EVM PCB Layers .....	3-3
3.3	TPA2008D2 EVM Parts List .....	3-4
3.4	DC Volume Table .....	3-5

# Figures

---

---

---

1-1	TPA2008D2 Audio Power Amplifier EVM Without Output Filter — Top View . . . . .	1-3
1-2	TPA2008D2 Audio Power Amplifier EVM Without Output Filter — Bottom View . . . . .	1-3
2-1	Quick Start Platform Map . . . . .	2-2
2-2	Module Preparation . . . . .	2-4
2-3	Quick Start for Stand-Alone Operation . . . . .	2-5
3-1	TPA2008D2 Filter-Free Class-D EVM Schematic Diagram . . . . .	3-2
3-2	TPA2008D2 Filter-Free Class-D EVM Top Assembly . . . . .	3-3
3-3	TPA2008D2 Filter-Free Class-D EVM Bottom Assembly . . . . .	3-3

# Tables

---

---

---

2-1	Typical Texas Instruments Plug-N-Play Platform Jumper and Switch Settings for the TPA2008D2 . . . . .	2-1
2-2	Platform Jumper and Switch Settings for the TPA2008D2 . . . . .	2-3
3-1	TPA2008D2 EVM Parts List . . . . .	3-4
3-2	TPA2008D2 EVM Volume Settings . . . . .	3-5

# Introduction

---

---

---

---

This chapter provides an overview of the Texas Instruments (TI) TPA2008D2 stereo filter-free class-D audio amplifier evaluation module (SLOP392). It includes a list of EVM features, a brief illustrated description of the module, and a list of EVM specifications.

<b>Topic</b>	<b>Page</b>
1.1 Feature Highlights .....	1-2
1.2 Description .....	1-3
1.3 TPA2008D2 EVM Specifications .....	1-4

## 1.1 Feature Highlights

The TI TPA2008D2 audio amplifier evaluation module and the TI plug-n-play audio amplifier evaluation platform include the following features:

- TPA2008D2 Stereo 3-W Filter-Free Class-D Audio Power Amplifier Evaluation Module
  - Class-D without output filter
  - Internal depop circuitry to minimize transients in outputs
  - High efficiency
  - Low distortion
  - Low supply current (7 mA)
  - 3 W per channel output power into 3  $\Omega$  at 5 V
  - Low current consumption in shutdown mode
  - DC volume control from –38 dB to 20 dB
  - Differential stereo inputs
  - 24-pin TSSOP PWP package
- Quick and Easy Configuration With the TI Plug-N-Play Audio Amplifier Evaluation Platform
  - Evaluation module is designed to simply plug into the platform, automatically making all signal, control, and power connections
  - Platform provides flexible power options
  - Jumpers on the platform select power and module control options
  - Switches on the platform route signals
  - Platform provides quick and easy audio input and output connections
- Platform Power Options
  - External 5-V – 15-V dc  $V_{CC}$  supply inputs
  - External regulated  $V_{DD}$  supply input
  - Socket for onboard 5 V/3.3 V  $V_{DD}$  voltage regulator EVM
  - Onboard overvoltage and reverse polarity power protection
- Platform Audio Input and Output Connections
  - Left and right RCA phono jack inputs
  - Miniature stereo phone jack input
  - Left and right RCA phono jack outputs
  - Left and right compression speaker terminal outputs
  - Miniature stereo headphone jack output

## 1.2 Description

The TPA2008D2 filter-free class-D stereo audio power amplifier evaluation module is a complete, 3-W per channel class-D stereo audio power amplifier that can operate without an output filter. It consists of the TI TPA2008D2 class-D stereo 3-W audio power amplifier IC along with a small number of other parts mounted on a circuit board that measures approximately 2-1/4 inches by 1-1/2 inches.

Figure 1–1. TPA2008D2 Audio Power Amplifier EVM Without Output Filter—Top View

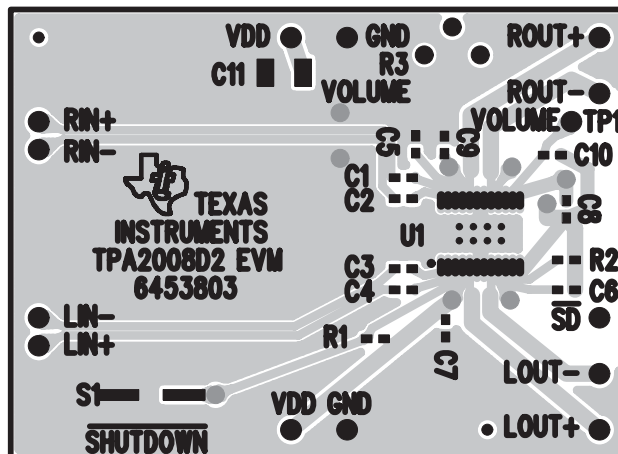
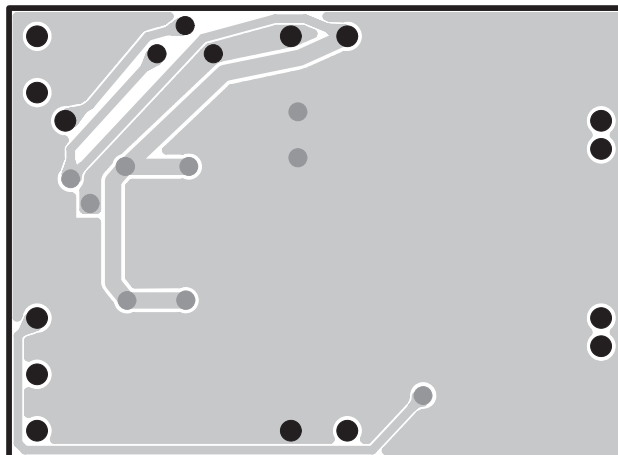

Figure 1–2. TPA2008D2 Audio Power Amplifier EVM Without Output Filter—Bottom View



Single in-line header pins extend from the underside of the module circuit board to allow the EVM to be plugged into the TI plug-n-play audio amplifier evaluation platform, or to be wired directly into existing circuits and equipment when used stand-alone.

The platform has room for a single TPA2008D2 evaluation module and is a convenient vehicle for demonstrating TI's audio power amplifier and related evaluation modules. The EVMs simply plug into the platform, which automatically provides power to the modules, interconnects them correctly, and connects them to a versatile array of standard audio input and output jacks and connectors. Easy-to-use configuration controls allow the platform and EVMs to quickly model many possible end-equipment configurations.

There is nothing to build, nothing to solder, and nothing but the speakers included with the platform to *hook up*.

### 1.3 TPA2008D2 EVM Specifications

Supply voltage range, $V_{DD}$ .....	4.5 V to 5.5 V
Supply current, $I_{DD}$ .....	2 A max
Continuous output power per channel, $P_O$ : $3 \Omega$ , $V_{DD} = 5 V$ .....	3 W
Minimum load impedance, $R_L$ .....	$3 \Omega$

## Operation

The steps in this chapter can be followed to quickly prepare the TPA2008D2 stereo filter-free class-D audio amplifier EVM for use. Using the TPA2008D2 with the TI plug-n-play audio amplifier evaluation platform is a quick and easy way to connect power, signal and control inputs, and signal outputs to the EVM using standard connectors. However, the audio amplifier evaluation module can be used stand-alone by making connections directly to the module pins, and can be wired directly into existing circuits or equipment.

The platform switch and jumper settings shown in Table 2–1 are typical for the TPA2008D2 EVM and causes the TPA2008D2 to shut down when a plug is inserted into platform headphone jack J10.

Table 2–1. Typical TI Plug-N-Play Platform Jumper and Switch Settings for the TPA2008D2

EVM	JP4	JP5	JP6	JP7	JP8	S2	S3
P-N-P Platform	X	ON	Mute	X	Lo	Note 2	U5

**Notes:** 1) ON = Jumper installed, OFF = Jumper **NOT** Installed, X = Don't care  
 2) Set S2 to ON when signal conditioning board is installed in U1; set S2 to OFF when no signal conditioning board is installed.

Topic	Page
2.1 Precautions .....	2–2
2.2 Quick Start List for Platform .....	2–3
2.3 Quick Start List for Stand-Alone .....	2–4
2.4 Power Requirements .....	2–6

## 2.1 Precautions

**Power Supply Input Polarity and Maximum Voltage**  
 Always ensure that the polarity and voltage of the external power connected to  $V_{CC}$  power input connector J1, J2, and/or  $V_{DD}$  power input connector J6 are correct. Overvoltage or reverse-polarity power applied to these terminals can open onboard soldered-in fuses and cause other damage to the platform, installed evaluation modules, and/or the power source.

**Inserting or Removing EVM Boards**  
 Do not insert or remove EVM boards with power applied—damage to the EVM board, the platform, or both may result.

Figure 2–1. Quick Start Platform Map

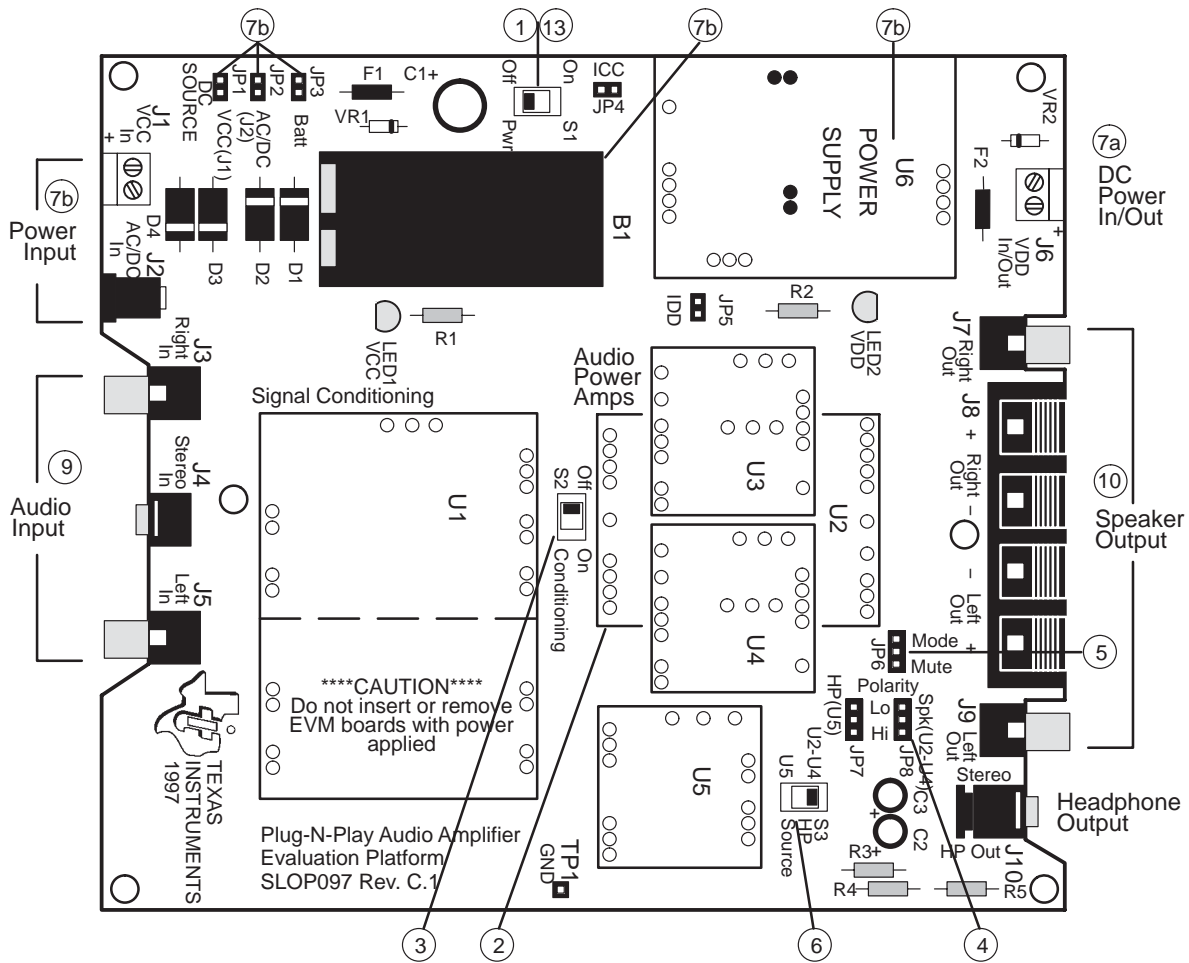

## 2.2 Quick Start List for Platform

Follow these steps when using the TPA2008D2 EVM with the TI plug-n-play audio amplifier evaluation platform (see the platform user's guide, literature number SLOU011, for additional details). Numbered callouts for selected steps are shown in Figure 2–2, and details appear in Chapter 3.

### Platform preparations

- 1) Ensure that all external power sources are set to OFF and that the platform power switch S1 is set to OFF.
- 2) Install a TPA2008D2 module in platform socket U2, taking care to align the module pins correctly.
- 3) Use switch S2 to select or bypass the signal conditioning EVM (U1).
- 4) Set control signal Polarity jumper JP8 to Lo.
- 5) Set jumper JP6 to select the Mute control input (causes the TPA2008D2 to shut down if a plug is inserted into platform headphone jack J10).
- 6) If a headphone amplifier will be installed in U5, set the headphone source switch S3 to U5.

Table 2–2. Platform Jumper and Switch Settings for the TPA2008D2

EVM	JP4	JP5	JP6	JP7	JP8	S2	S3
P-N-P Platform	X	ON	Mute	X	Lo	Note 2	U5

**Notes:** 1) ON = Jumper installed, OFF = Jumper NOT Installed, X = Don't care  
 2) Set S2 to ON when signal conditioning board is installed in U1; set S2 to OFF when no signal conditioning board is installed.

### Power supply

- 7) Select and connect the power supply (ensure power supply is set to OFF):
  - a) Connect an external regulated power supply set to 5 V to platform  $V_{DD}$  power input connector J6 taking care to observe marked polarity, or
  - b) Install a voltage regulator EVM (SLVP097 or equiv.) in platform socket U6. Connect a 7-V – 12-V power source to a platform  $V_{CC}$  power input J1 or J2 and jumper the appropriate power input (see platform user's guide). If using J1, J2, or B1, set S1 to ON to supply power to the EVM.

### Inputs and outputs

- 8) Ensure that the audio signal source level is set to minimum.
- 9) Connect the audio source to left and right RCA phono jacks J3 and J5 or stereo miniature phone jack J4.
- 10) Connect speakers to left and right RCA jacks J7 and J9 or to stripped wire speaker connectors J8.

**Evaluation Module Preparations**

- 11) Use potentiometer R3 to set the volume. Turning R3 in the clockwise direction will increase the volume. See Table 3–1 for voltage levels on the VOLUME pin and corresponding gain settings.
- 12) If using an external DAC, adjust R3 to the center position by placing a DMM across the VOLUME pin and ground and adjusting the potentiometer until 25 kΩ is measured across the leads. Apply the external source to the VOLUME pin. Be sure to use the board VDD as a reference for the DAC. Also connect the reference GND of the DAC to the GND terminal of the EVM.

Figure 2–2. Module Preparation

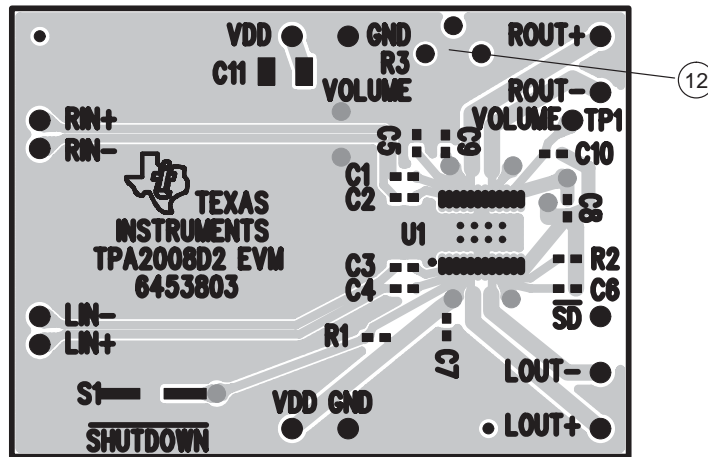

**Power Up**

- 13) Verify correct voltage and input polarity and set the external power supply to ON. If  $V_{CC}$  and an on-board regulator EVM are used to provide  $V_{DD}$ , set platform power switch S1 to ON.  
  
Platform LED2 should light indicating the presence of  $V_{DD}$ , and the evaluation modules installed on the platform should begin operation.
- 14) Adjust the signal source level and potentiometer R3 as needed.

**2.3 Quick Start List for Stand-Alone**

Follow these steps to use the TPA2008D2 EVM stand-alone or when connecting it into existing circuits or equipment. Connections to the TPA2008D2 module header pins can be made via individual sockets, wire-wrapping, or soldering to the pins, either on the top or the bottom of the module circuit board. Numbered callouts for selected steps are shown in Figure 2–3.

Figure 2–3. Quick Start for Stand-Alone

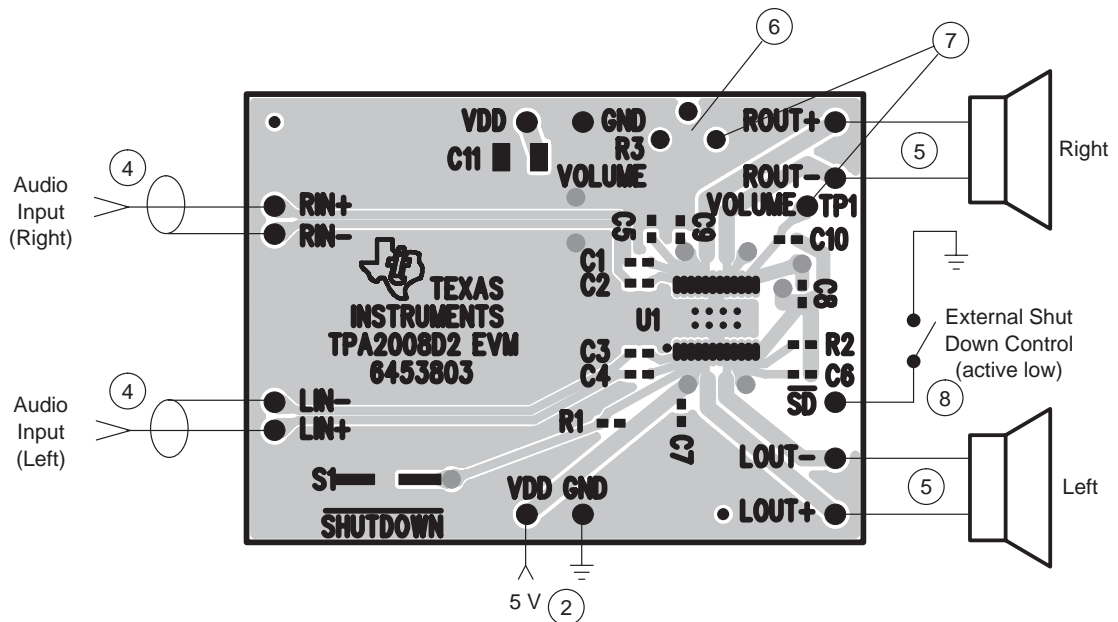

**Power supply**

- 1) Ensure that all external power sources are set to OFF.
- 2) Connect an external regulated power supply set to 5 V to the module VDD and GND pins taking care to observe marked polarity.

**Inputs and outputs**

- 3) Ensure that audio signal source level adjustments are set to minimum.
- 4) Connect the right (left) positive lead of the audio source to the module RIN+ (LIN+) pins and the negative lead to the RIN- (LIN-) pins.
- 5) Connect speakers to the left and right outputs.

**Evaluation module preparations**

- 6) Use potentiometer R3 to set the volume. Turning R3 in the clockwise direction will increase the volume. See Table 3–1 for voltage levels on the VOLUME pin and corresponding gain settings.
- 7) If using an external DAC, adjust R3 to the center position by placing a DMM across the VOLUME pin and ground and adjusting the potentiometer until 25 k $\Omega$  is measured across the leads. Apply the external source to the VOLUME pin. Be sure to use the board VDD as a reference for the DAC. Also connect the reference GND of the DAC to the GND terminal of the EVM.

**Control inputs**

- 8) **SHUTDOWN**: A low shuts down the amplifier IC on the module; a high or float allows normal operation.

**Power up**

- 9) Verify correct voltage and input polarity and set the external power supply to ON.

The EVM should begin operation.

10) Adjust the signal source level and potentiometer R3 as needed.

## 2.4 Power Requirements

The TPA2008D2 audio power amplifier evaluation module can operate from any voltage between approximately 4.5 V and 5.5 V; however, the TPA2008D2 amplifier IC on the module is characterized for operation at 5 V. For best performance (highest output power with lowest distortion), the module should be operated at 5 V.

The TI plug-n-play audio amplifier evaluation platform with a voltage regulator EVM installed on it can provide a regulated  $V_{DD}$  supply from a wide variety of unregulated  $V_{CC}$  voltage inputs between 5.5 V and 12 V, including an onboard 9-V battery. Alternatively, an external regulated power source can be used to supply  $V_{DD}$  voltage to the platform and the TPA2008D2 evaluation module installed on it.

Although the TPA2008D2 amplifier IC draws approximately 1 A from the power supply during continuous full power output, peak current draw can be as high as 2 A. Any power supply connected to the platform should be capable of providing 2 A of current to avoid clipping of the output signal during peaks. Current consumption driving speakers at normal listening levels is typically 0.1 A or less.

The platform is equipped with overvoltage and reverse-polarity supply voltage input protection in the form of fused crowbar circuits.

- $V_{DD}$  voltage applied to platform screw terminals J6 *MUST NOT* exceed the absolute maximum rating for the TPA2008D2 amplifier IC installed on the evaluation module (6 V) or damage to the IC may result. In no case should  $V_{DD}$  voltage of the incorrect polarity or in excess of 6.1 V be applied to screw terminals J6 of the platform, or the power protection circuit on the  $V_{DD}$  line will trip.
- $V_{CC}$  voltage applied to the platform *MUST NOT* exceed the maximum voltage input specified for the voltage regulator module installed in socket U6 (12 V for the SLVP097), or damage to the voltage regulator module may result. In no case should  $V_{CC}$  voltage applied to the platform exceed 15 V, or the overvoltage protection circuit on the  $V_{CC}$  bus will trip.

# Reference

---

---

---

---

This chapter contains the EVM schematic, PCB layers, parts list, and dc volume control table.

<b>Topic</b>	<b>Page</b>
3.1 TPA2008D2 EVM Schematic .....	3-2
3.2 TPA2008D2 EVM PCB Layers .....	3-3
3.3 TPA2008D2 EVM Parts List .....	3-4
3.4 DC Volume Table .....	3-5

### 3.1 TPA2008D2 EVM Schematic

Figure 3–1. TPA2008D2 Filter-Free Class-D EVM Schematic Diagram

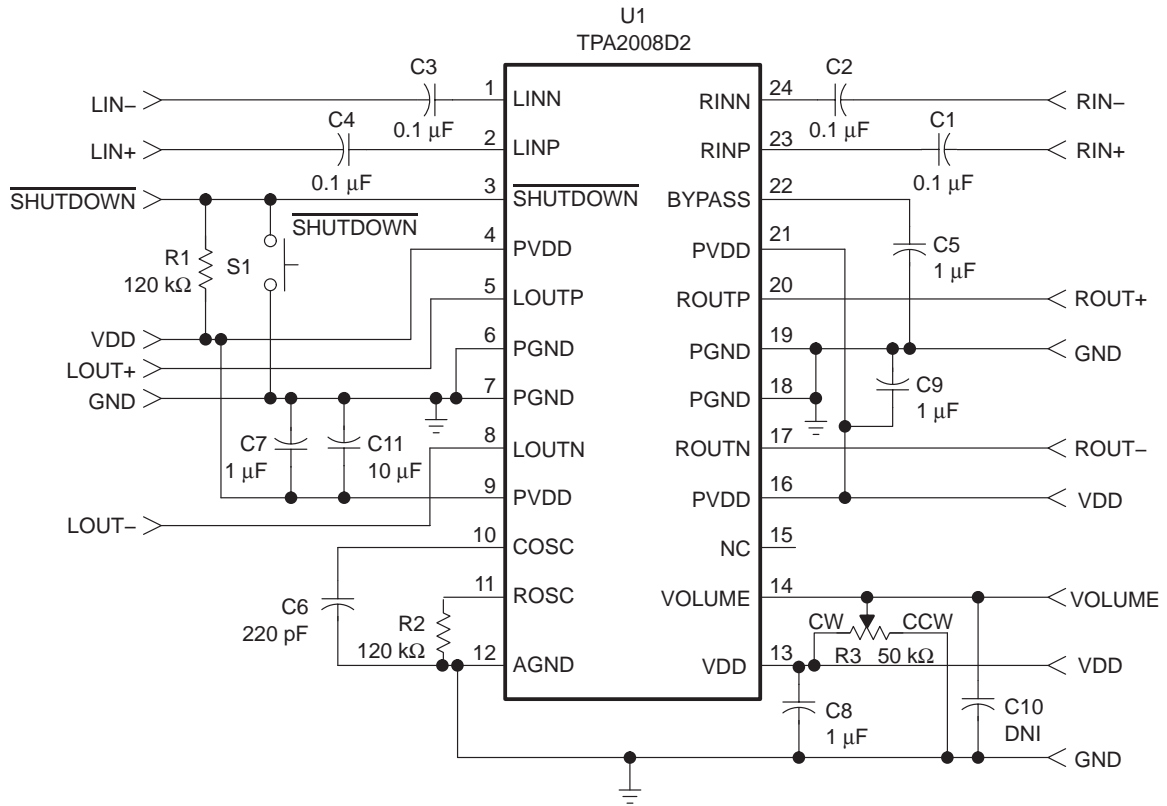

### 3.2 TPA2008D2 EVM PCB Layers

Figure 3–2 and Figure 3–3 depict the TPA2008D2 EVM PCB layers. These drawings are not to scale. Gerber plots can be obtained from any TI sales office.

Figure 3–2. TPA2008D2 EVM Top Assembly

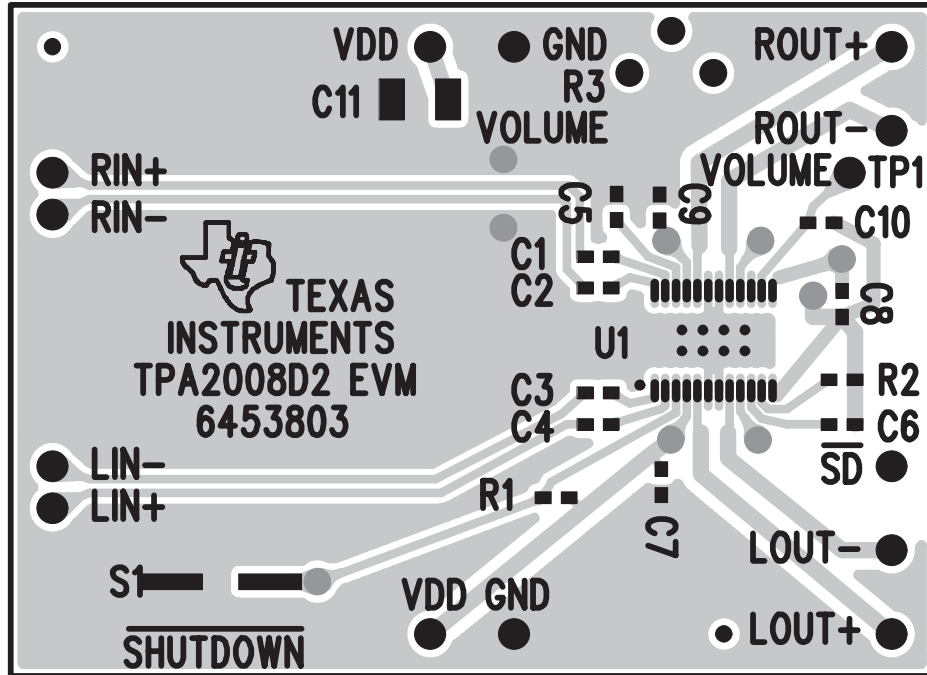
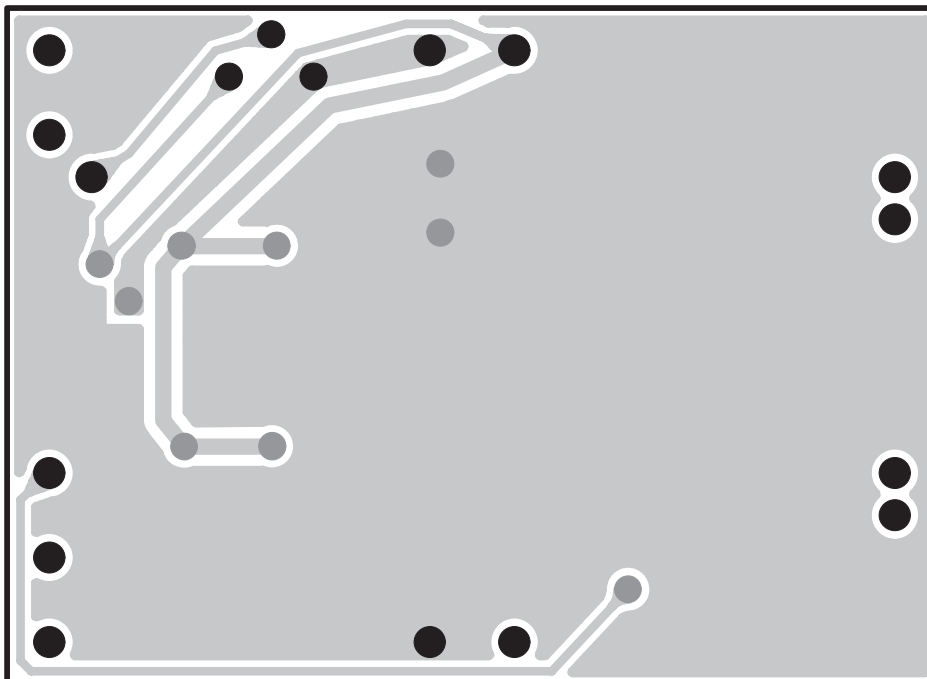

Figure 3–3. TPA2008D2 EVM Bottom Assembly



### 3.3 TPA2008D2 EVM Parts List

Table 3–1. TPA2008D2 EVM Parts List

Reference	Description	Size	EVM Qty.	Manufacturer/ Part Number	Vendor/ Part Number
C1, C2, C3, C4	Capacitor, 0.1 $\mu$ F, $\pm$ 5%, X7R, 16 V	603	4	Panasonic ECJ–1VB1C104K	Digi-Key PCC1762CT–ND
C5, C7, C8, C9	Capacitor, 1 $\mu$ F, 80%/–20%, Y5V, 10 V	603	4	Panasonic ECJ–1VF1A105Z	Digi-Key PCC1787CT–ND
C10	No not install				
C6	Capacitor, 220 pF, $\pm$ 5%, X7R, 50 V	603	1	Panasonic ECJ–1VC1h221J	Digi-Key PCC221ACVCT–ND
C11	Capacitor, 10 $\mu$ F, 80%/–20%, Y5V, 16 V	1210	1	Murata GRM23SY5V106Z016AK	Arrow GJ232NF51C106ZD 01
R1, R2	Resistor, 120 k $\Omega$ , 1/16 W, 5%	603	2	Panasonic ERJ–3GEYJ124V	Digi-Key P120K6CT–ND
R3	Potentiometer, 50 k $\Omega$ , Cermet ST SL, thru hole		1	Bourns 3362P–1–503	Digi-Key 3362P–503–ND
S1	Switch, momentary pushbutton, 12 V, 50 mA	SMD	1	Panasonic EVQ–PPBA25	Digi-Key P8086SCT–ND
	Headers, 0.1 in centers, 1/2 in long	0.5 X 0.25 X 0.1"	13	Sullin PTC36SABN	Digi-Key S1022–36–ND
TP1	Test point, 0.040" mounting hole		1	Farrell 240–345	
U1	IC, 3-W, stereo class-D audio power amplifier	24-pin TSSOP	1	TI TPA2008D2PWP	
PCB	PCB, 2 layer, fits U2 on PnP	2.25" X 1.25"	1	TI TPA2008D2EVM	

### 3.4 DC Volume Table

Table 3-2. DC Volume Control

Voltage on VOLUME Pin (V) (Increasing or Fixed Gain)	Voltage on VOLUME Pin (V) (Decreasing Gain)	Gain of Amplifier (dB) <sup>(1)</sup>
0–0.33	0.31–0	–38 <sup>(2)</sup>
0.34–0.42	0.43–0.32	–37
0.43–0.52	0.54–0.44	–35
0.53–0.63	0.64–0.55	–33
0.64–0.75	0.75–0.65	–31
0.76–0.86	0.86–0.76	–29
0.87–0.97	0.97–0.87	–27
0.98–1.07	1.08–0.98	–25
1.08–1.18	1.19–1.09	–23
1.19–1.30	1.32–1.20	–21
1.31–1.41	1.42–1.33	–19
1.42–1.52	1.53–1.43	–17
1.53–1.63	1.63–1.54	–15
1.64–1.75	1.75–1.64	–13
1.76–1.85	1.84–1.76	–12
1.86–1.96	1.96–1.85	–10
1.97–2.07	2.09–1.97	–8
2.08–2.18	2.19–2.10	–6
2.19–2.30	2.33–2.20	–4
2.31–2.40	2.43–2.34	–2
2.41–2.52	2.49–2.44	0 <sup>(2)</sup>
2.53–2.63	2.62–2.50	2
2.64–2.75	2.75–2.63	4
2.76–2.87	2.85–2.76	6
2.88–2.98	2.99–2.86	8
2.99–3.10	3.12–3.00	10
3.11–3.22	3.25–3.13	12
3.23–3.33	3.36–3.26	14
3.34–3.47	3.48–3.37	16
3.48–3.69	3.64–3.49	18
3.70–V <sub>DD</sub>	V <sub>DD</sub> –3.65	20 <sup>(2)</sup>

1) The Typical part-to-part variation can be as large as  $\pm 2$ dB (one gain step)

2) Tested in production



## Данный компонент на территории Российской Федерации

### Вы можете приобрести в компании MosChip.

Для оперативного оформления запроса Вам необходимо перейти по данной ссылке:

<http://moschip.ru/get-element>

Вы можете разместить у нас заказ для любого Вашего проекта, будь то серийное производство или разработка единичного прибора.

В нашем ассортименте представлены ведущие мировые производители активных и пассивных электронных компонентов.

Нашей специализацией является поставка электронной компонентной базы двойного назначения, продукции таких производителей как XILINX, Intel (ex.ALTERA), Vicor, Microchip, Texas Instruments, Analog Devices, Mini-Circuits, Amphenol, Glenair.

Сотрудничество с глобальными дистрибьюторами электронных компонентов, предоставляет возможность заказывать и получать с международных складов практически любой перечень компонентов в оптимальные для Вас сроки.

На всех этапах разработки и производства наши партнеры могут получить квалифицированную поддержку опытных инженеров.

Система менеджмента качества компании отвечает требованиям в соответствии с ГОСТ Р ИСО 9001, ГОСТ РВ 0015-002 и ЭС РД 009

### Офис по работе с юридическими лицами:

105318, г.Москва, ул.Щербаковская д.3, офис 1107, 1118, ДЦ «Щербаковский»

Телефон: +7 495 668-12-70 (многоканальный)

Факс: +7 495 668-12-70 (доб.304)

E-mail: [info@moschip.ru](mailto:info@moschip.ru)

Skype отдела продаж:

moschip.ru

moschip.ru\_4

moschip.ru\_6

moschip.ru\_9