



# BTA04 T/D/S/A BTB04 T/D/S/A

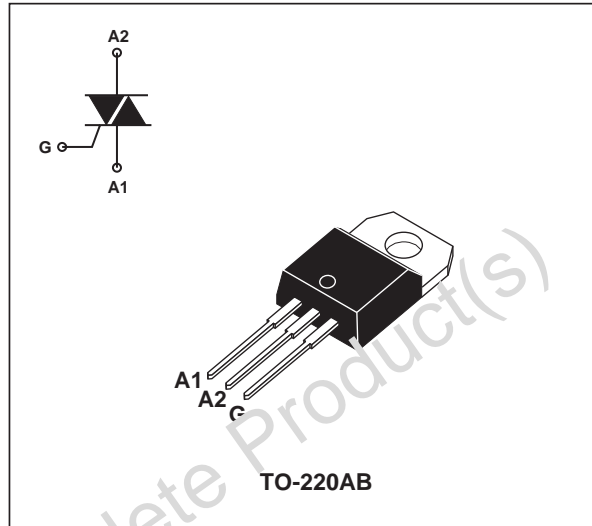
## SENSITIVE GATE TRIACS

### FEATURES

- Very low  $I_{GT} = 10\text{mA}$  max
- Low  $I_H = 15\text{mA}$  max
- BTA Family:  
Insulating voltage =  $2500V_{(RMS)}$   
(UL recognized: E81734)

### DESCRIPTION

The BTA/BTB04 T/D/S/A triac family are high performance glass passivated PNP devices. These parts are suitable for general purpose applications where gate high sensitivity is required. Application on 4Q such as phase control and static switching.



### ABSOLUTE RATINGS (limiting values)

Symbol	Parameter		Value	Unit	
$I_{T(RMS)}$	RMS on-state current (360° conduction angle)	BTA	$T_c = 90^\circ\text{C}$	4	A
		BTB	$T_c = 95^\circ\text{C}$		
$I_{TSM}$	Non repetitive surge peak on-state current ( $T_j$ initial = $25^\circ\text{C}$ )		$t_p = 8.3\text{ms}$	42	A
			$t_p = 10\text{ms}$		
$I^2t$	$I^2t$ value		$t_p = 10\text{ms}$	8	$\text{A}^2\text{s}$
$di/dt$	Critical rate of rise of on-state current Gate supply: $I_G = 50\text{mA}$ $di_G/dt = 0.1\text{A}/\mu\text{s}$		Repetitive $F = 50\text{Hz}$	10	$\text{A}/\mu\text{s}$
			Non repetitive	50	
$T_{stg}$ $T_j$	Storage and operating junction temperature range			-40 to +150 -40 to +110	$^\circ\text{C}$
$T_l$	Maximum lead soldering temperature during 10s at 4.5mm from case			260	$^\circ\text{C}$

Symbol	Parameter	BTA / BTB04-			Unit
		400 T/D/S/A	600 T/D/S/A	700 T/D/S/A	
$V_{DRM}$ $V_{RRM}$	Repetitive peak off-state voltage $T_j = 110^\circ\text{C}$	400	600	700	V

**THERMAL RESISTANCE**

Symbol	Parameter	Value	Unit
Rth (j-a)	Junction to ambient	60	°C/W
Rth (j-c) DC	Junction to case for DC	BTA	4.4
		BTB	3.2
Rth (j-c) AC	Junction to case for 360° conduction angle (F = 50Hz)	BTA	3.3
		BTB	2.4

**GATE CHARACTERISTICS (maximum values)**

$P_{G(AV)} = 1W$   $P_{GM} = 40W$  (tp = 20µs)  $I_{GM} = 4A$  (tp = 20µs)  $V_{GM} = 16V$  (tp = 20µs)

**ELECTRICAL CHARACTERISTICS**

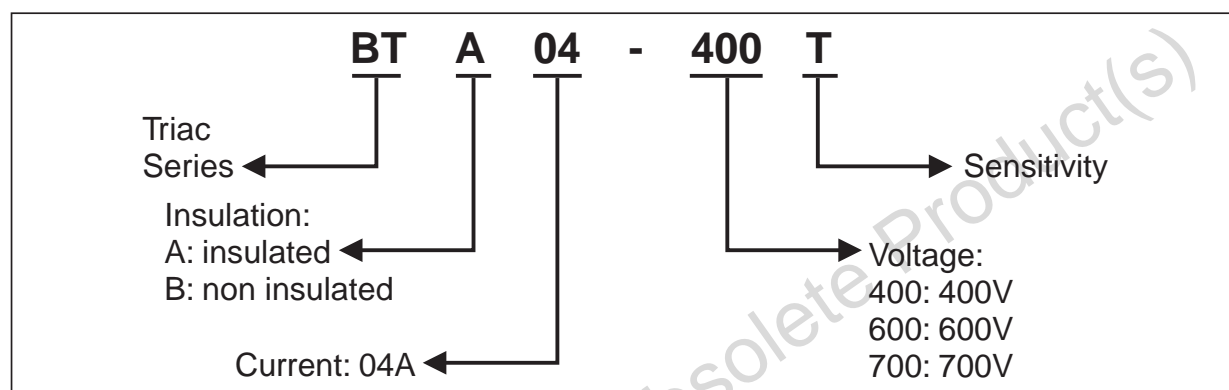
Symbol	Test conditions	Quadrant		BTA / BTB04				Unit
				T	D	S	A	
I <sub>GT</sub>	V <sub>D</sub> = 12V (DC) R <sub>L</sub> = 33Ω T <sub>j</sub> = 25°C	I - II - III	MAX.	5	5	10	10	mA
		IV	MAX.	5	10	10	25	
V <sub>GT</sub>	V <sub>D</sub> = 12V (DC) R <sub>L</sub> = 33Ω T <sub>j</sub> = 25°C	I - II - III - IV	MAX.	1.5				V
V <sub>GD</sub>	V <sub>D</sub> = V <sub>DRM</sub> R <sub>L</sub> = 3.3kΩ T <sub>j</sub> = 110°C	I - II - III - IV	MIN.	0.2				V
t <sub>gt</sub>	V <sub>D</sub> = V <sub>DRM</sub> I <sub>G</sub> = 40mA di <sub>G</sub> /dt = 0.5A/µs T <sub>j</sub> = 25°C	I - II - III - IV	TYP.	2				µs
I <sub>L</sub>	I <sub>G</sub> = 1.2I <sub>GT</sub> T <sub>j</sub> = 25°C	I - III - IV	TYP.	10	10	20	20	mA
		II		20	20	40	40	
I <sub>H</sub> *	I <sub>T</sub> = 100mA Gate open T <sub>j</sub> = 25°C		MAX.	15	15	25	25	mA
V <sub>TM</sub> *	I <sub>TM</sub> = 5.5A tp = 380µs T <sub>j</sub> = 25°C		MAX.	1.65				V
I <sub>DRM</sub> I <sub>RRM</sub>	V <sub>DRM</sub> rated V <sub>RRM</sub> rated T <sub>j</sub> = 25°C		MAX.	0.01				mA
			MAX.	0.75				
dV/dt*	Linear slope up to V <sub>D</sub> = 67% V <sub>DRM</sub> gate open T <sub>j</sub> = 110°C		TYP.	10	10	-	-	V/µs
			MIN.	-	-	10	10	
(di/dt) <sub>c</sub> *	(di/dt) <sub>c</sub> = 1.8A/ms T <sub>j</sub> = 110°C		TYP.	1	1	5	5	V/µs

\* For either polarity of electrode A<sub>2</sub> voltage with reference to electrode A<sub>1</sub>

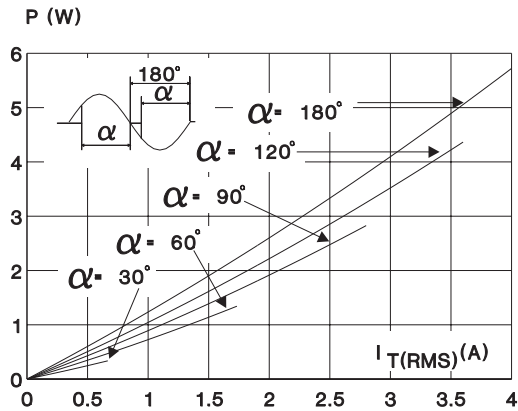
**PRODUCT INFORMATION**

Package	$I_{T(RMS)}$	$V_{DRM} / V_{RRM}$	Sensitivity Specification			
	A	V	T	D	S	A
BTA (Insulated)	4	400	X			X
		600	X	X		
		700	X		X	
BTB (Uninsulated)	4	400	X	X		
		600	X		X	

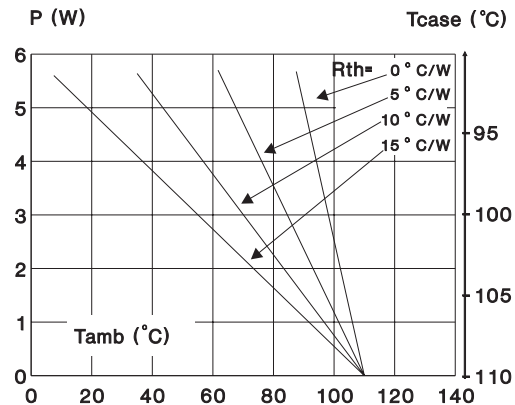
**ORDERING INFORMATION**



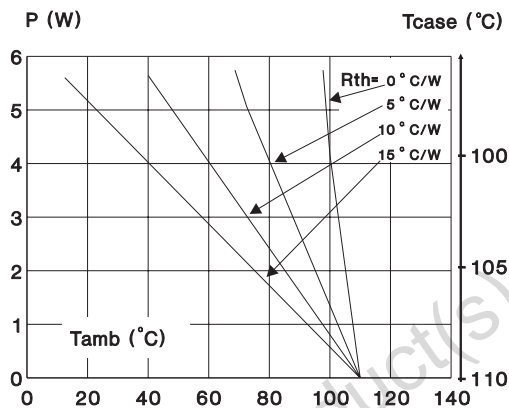
**Fig. 1:** Maximum RMS power dissipation versus RMS on-state current ( $F = 50\text{Hz}$ ). (Curves are cut off by  $(di/dt)_c$  limitation)



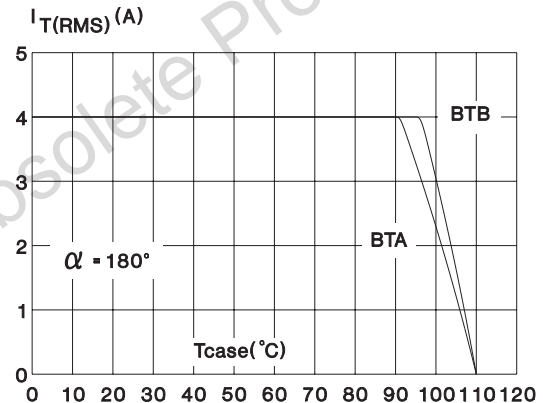
**Fig. 2:** Correlation between maximum RMS power dissipation and maximum allowable temperature ( $T_{amb}$  and  $T_{case}$ ) for different thermal resistances heatsink + contact (BTA).



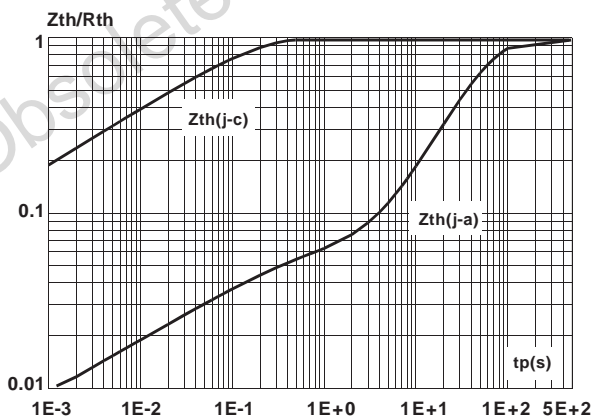
**Fig. 3:** Correlation between maximum RMS power dissipation and maximum allowable temperature ( $T_{amb}$  and  $T_{case}$ ) for different thermal resistances heatsink + contact (BTB).



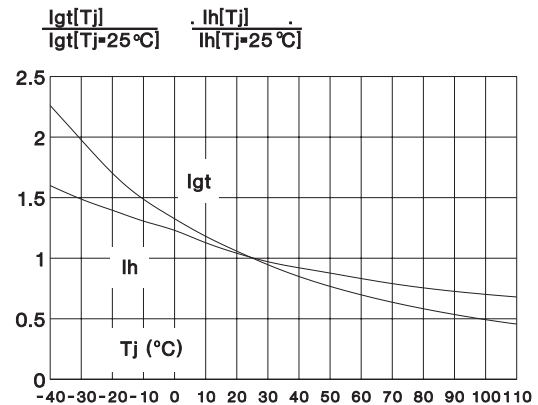
**Fig. 4:** RMS on-state current versus case temperature.



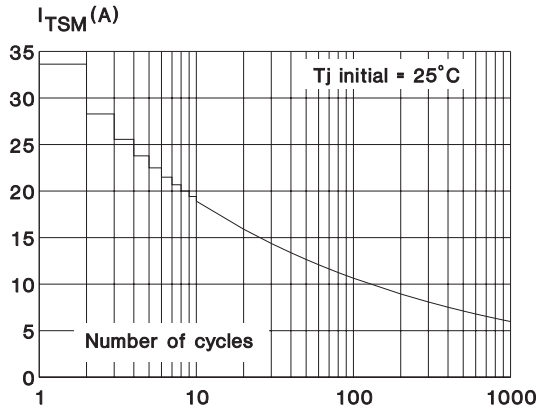
**Fig. 5:** Relative variation of thermal impedance versus pulse duration.



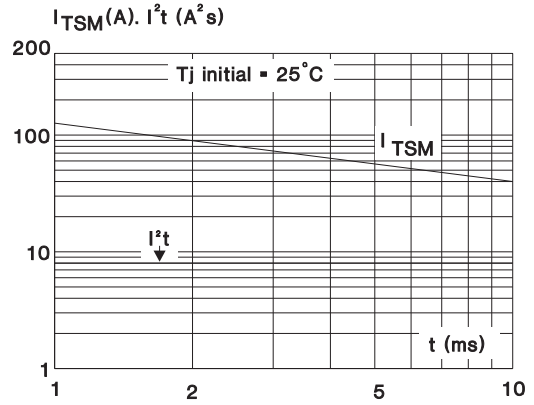
**Fig. 6:** Relative variation of gate trigger current and holding current versus junction temperature.



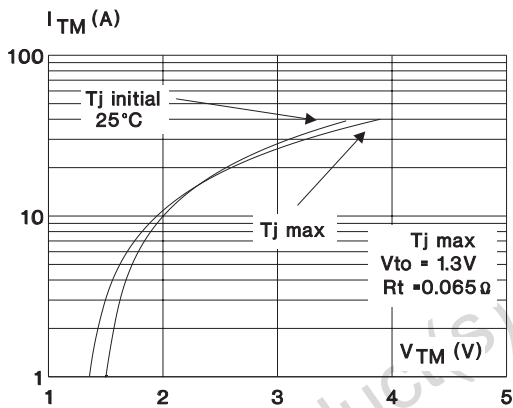
**Fig. 7:** Non repetitive surge peak on-state current versus number of cycles.



**Fig. 8:** Non repetitive surge peak on-state current for a sinusoidal pulse with width:  $t \leq 10\text{ms}$ , and corresponding value of  $I^2t$ .

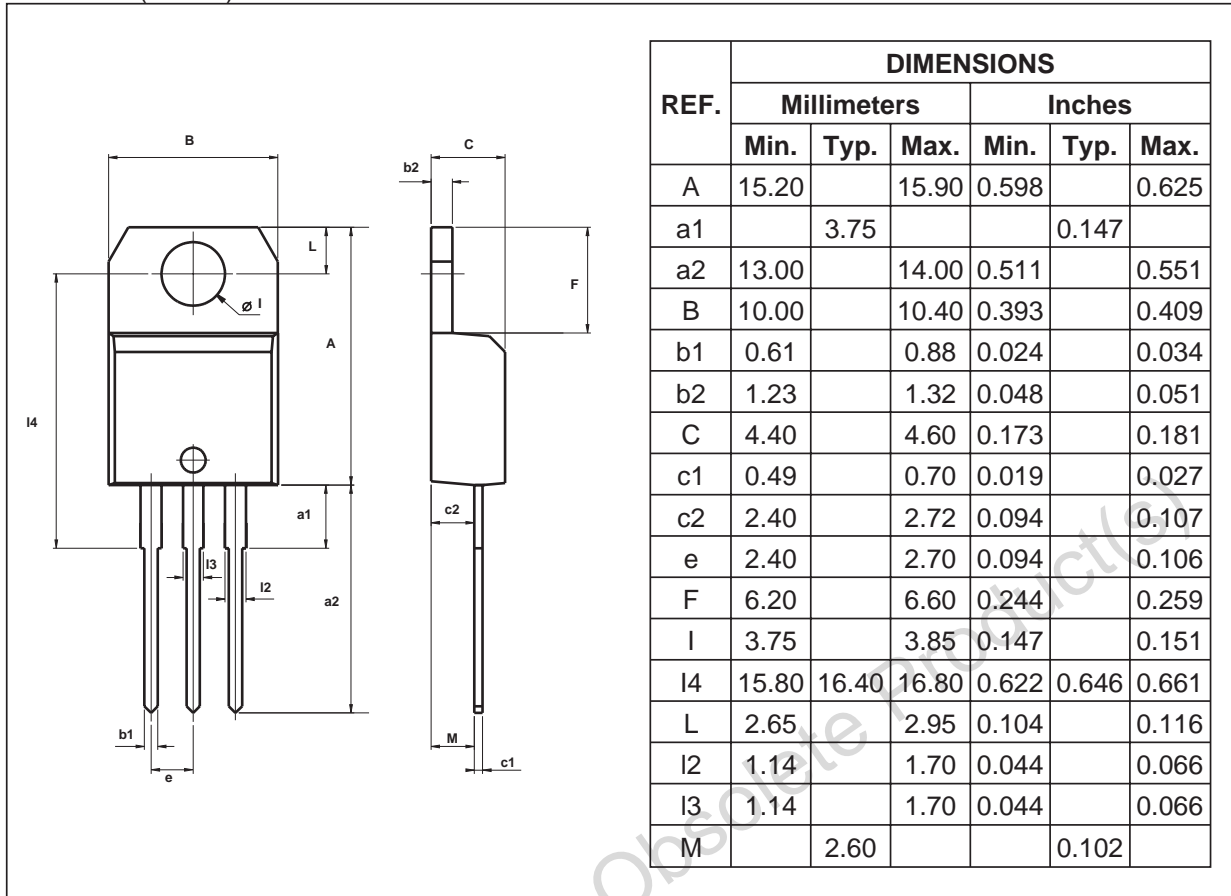


**Fig. 9:** On-state characteristics (maximum values).



Obsolete Product(s) - Obsolete Product(s)

**PACKAGE MECHANICAL DATA**  
TO-220AB (Plastic)



**OTHER INFORMATION**

Ordering type	Marking	Package	Weight	Base qty	Delivery mode
BTA/BTB04-xxxy	BTA/BTB04-xxxy	TO-220AB	2.3 g	250	Bulk

- Epoxy meets UL94,V0
- Cooling method: C
- Recommended torque value: 0.8 m.N.
- Maximum torque value: 1 m.N.

Information furnished is believed to be accurate and reliable. However, STMicroelectronics assumes no responsibility for the consequences of use of such information nor for any infringement of patents or other rights of third parties which may result from its use. No license is granted by implication or otherwise under any patent or patent rights of STMicroelectronics. Specifications mentioned in this publication are subject to change without notice. This publication supersedes and replaces all information previously supplied. STMicroelectronics products are not authorized for use as critical components in life support devices or systems without express written approval of STMicroelectronics.

The ST logo is a registered trademark of STMicroelectronics

© 2001 STMicroelectronics - Printed in Italy - All rights reserved.

STMicroelectronics GROUP OF COMPANIES

Australia - Brazil - China - Finland - France - Germany - Hong Kong - India - Italy - Japan - Malaysia  
Malta - Morocco - Singapore - Spain - Sweden - Switzerland - United Kingdom - U.S.A.

<http://www.st.com>

## Данный компонент на территории Российской Федерации

### Вы можете приобрести в компании MosChip.

Для оперативного оформления запроса Вам необходимо перейти по данной ссылке:

<http://moschip.ru/get-element>

Вы можете разместить у нас заказ для любого Вашего проекта, будь то серийное производство или разработка единичного прибора.

В нашем ассортименте представлены ведущие мировые производители активных и пассивных электронных компонентов.

Нашей специализацией является поставка электронной компонентной базы двойного назначения, продукции таких производителей как XILINX, Intel (ex.ALTERA), Vicor, Microchip, Texas Instruments, Analog Devices, Mini-Circuits, Amphenol, Glenair.

Сотрудничество с глобальными дистрибьюторами электронных компонентов, предоставляет возможность заказывать и получать с международных складов практически любой перечень компонентов в оптимальные для Вас сроки.

На всех этапах разработки и производства наши партнеры могут получить квалифицированную поддержку опытных инженеров.

Система менеджмента качества компании отвечает требованиям в соответствии с ГОСТ Р ИСО 9001, ГОСТ РВ 0015-002 и ЭС РД 009

### Офис по работе с юридическими лицами:

105318, г.Москва, ул.Щербаковская д.3, офис 1107, 1118, ДЦ «Щербаковский»

Телефон: +7 495 668-12-70 (многоканальный)

Факс: +7 495 668-12-70 (доб.304)

E-mail: [info@moschip.ru](mailto:info@moschip.ru)

Skype отдела продаж:

moschip.ru

moschip.ru\_4

moschip.ru\_6

moschip.ru\_9