

AEDB-9340 Series

1250/2500 CPR Commutation Encoder Modules
with Codewheel



Data Sheet



Description

The AEDB-9340 optical encoder series are six-channel optical incremental encoder modules with codewheel. The encoder is compliant to RoHS directive and had been declared as a lead free product. When used with codewheel, these modules detect rotary position. Each module consists of a collimated LED source and detector IC enclosed within a small plastic package. Due to highly collimated light source and unique photo detector array designs, these modules are extremely tolerant to mounting misalignment.

The AEDB-9340 optical encoder has integrated commutation output (U, V, W), two-channel quadrature outputs plus a third channel index output (A, B, I). This ungated index output is a positive index pulse that is generated once for each full rotation of the codewheel.

The AEDB-9340 series optical encoder is designed for use with a codewheel that has an optical radius of 15 mm (0.590 inch) for 1250/2500 CPR, 12.3 mm (0.484 inch) for 1024/2048 CPR and 12 mm (0.472 inch) for 1000/2000 CPR.

The quadrature, index, commutation signals and power supplied to encoder are accessed through eight 0.46 mm square male connector pins located on 1.27 mm (pitch).

The AEDB-9340 optical encoder provides advanced motion control detection with integrated commutation outputs (U, V, and W). It is equivalent to those produced by Hall Switches, thus making it ideal for servo motor application. With the AEDB-9340 solution, the system will be more compact, have reduced alignment time with usage of alignment jig, thus making assembly process much easier for housed encoder integration. It has superior switching accuracy due to much lower hysteresis when compared to a Hall Switches. The commutation signals can be generated for Brushless DC motor of different rotor pole-pairs by simply changing with matching pole-pair codewheel.

Features

- Two-channel quadrature output with ungated index pulse (A, B, I)
- Three-channel integrated commutation output (U, V, W)
- Up to 2500 Cycles Per Revolution (CPR)
- Easy assembly with alignment jig
- Designed to fit into circular shaped housing
- Up to 150 kHz frequency response
- -10°C to 85°C operating temperature
- TTL compatible
- Single 5 V supply
- Integrated feedback device for Brushless DC Motor

Applications

Typical applications include industrial printers, plotters, tape drives, and industrial and factory automation equipment.

Note: Avago Technologies encoders are not recommended for use in safety critical applications, e.g., ABS braking systems, power steering, life support systems and critical care medical equipment. Please contact sales representative if more clarification is needed.

Theory of Operation

The AEDB-9340 optical encoder is a emitter-detector module. Coupled with codewheel, these modules translate the rotary motion of a shaft into six-channel digital output.

The modules contain a single Light Emitting Diode (LED) as light source. The light is collimated into a parallel beam by means polycarbonate lens located directly over the LED. Opposite the emitter is a detector IC. This IC consists of multiple sets of photo detectors and signal processing circuitry necessary to produce digital waveforms output.

The codewheel rotates between the emitter and detector, causing the light beam to be interrupted by pattern of spaces and bars on the codewheel.

The Photodiodes that detect these interruptions are arranged in a pattern that corresponds to the radius and design of the codewheel. These detectors are also spaced in such away that light period on one pair of detectors corresponds to dark period on adjacent pair of detectors.

The photodiode outputs are then fed through the signal processing circuitry resulting in A, \bar{A} , B, \bar{B} , I, and \bar{I} . Comparators receive these signals and produce the final outputs for channels A and B. Due to this integrated phasing technique, the digital output of channel A is in quadrature with that of channel B (90 degrees out of phase). The commutation feedback (U, V, W) signals are generated based on the codewheel design.

Definitions

Cycles (N): The number of electrical cycles per revolution (CPR). Note: CPR refers to the raw signal from encoder, that is the cycles before 4x decode.

One Cycle: 360 electrical degrees ($^{\circ}$ e).

One Shaft Rotation: 360 mechanical degrees.

Cycle Error (ΔC): An indication of cycle uniformity. The difference between an observed shaft angle which gives rise to one electrical cycle, and the nominal angular increment of $1/N$ of a revolution.

Pulse Width (P): The number of electrical degrees that an output is high during 1 cycle. This value is nominally 180° e or $1/2$ cycle.

Pulse Width Error (ΔP): The deviation, in electrical degrees, of the pulse width from its ideal value of 180° e.

State Width (S): The numbers of electrical degrees between transitions in the output of channel A and the neighboring transition in the output of channel B. There are 4 states per cycle, each nominally 90° e.

State Width Error (ΔS): The deviation, in electrical degrees, of each state width from its ideal value of 90° e.

Commutation Accuracy (ΔI): The deviation, in mechanical degrees, after shaft rotates passing the reference point (Index channel) to the first Channel-U pulse. The measurement from middle of Channel-I to rising edge of Channel-U.

Phase (ϕ): The numbers of electrical degrees between the center of the high state of channel A and the center of the high state of channel B. This value is nominally 90° e for quadrature output.

This value is nominally 90° e for quadrature output.

Phase Error ($\Delta\phi$): The deviation of the phase from its ideal value of 90° e.

Direction of Rotation: When the codewheel rotates in the clockwise direction viewing from top of the module (direction from pin U to B), channel A will lead channel B. If the codewheel rotates in the opposite direction (direction from pin B to U), channel B will lead channel A.

Optical Radius (Rop): The distance from the codewheel's center of rotation to the optical center (O.C.) of the encoder module.

Index Pulse Width (Po): The number of electrical degrees that an index is high with reference to channel A or channel B during one full shaft rotation.

Absolute Maximum Ratings

Parameter	Symbol	Min.	Max.	Units	Notes
Storage Temperature	T_S	-40	85	°C	
Operating Temperature	T_A	-10	85	°C	
Supply Voltage	V_{CC}	-0.5	7	Volts	

Recommended Operating Conditions

Parameter	Min.	Typ.	Max.	Units	Notes
Temperature	-10	25	85	°C	
Supply Voltage (Detector)	4.5	5.0	5.5	Volts	Ripple < 100 mVpp
Operating Frequency					
1250 CPR			75	kHz	Velocity (rpm) x N/60
2500 CPR			150	kHz	
Shaft Radial Play Plus Eccentricity			±0.025	mm TIR	
Shaft Axial Play			±0.100	mm	

Electrical Characteristics

Electrical Characteristics over Recommend Operating Range, Typical at 25°C

Parameter	Symbol	Min.	Typ.	Max.	Units	Notes
Supply Current	I_{CC}	40	60	80	mA	
High Level Output Voltage	V_{OH}	2.4			V	
Low Level Output Voltage	V_{OL}			0.4	V	
Rise Time	t_r		200		ns	$C_L = 14$ pF
Fall Time	t_f		20		ns	
Loading Capacitance	C_{LOAD}			47	pF	

Encoding Characteristics

Encoding Characteristics over the Recommended Operating Conditions and Mounting tolerances. These characteristics include codewheel contribution. The typical values are average over the full rotation of the codewheel tested at 25°C, 500 RPM, 5V.

Parameter	Symbol	Minimum	Typical	Maximum	Units
Pulse Width Error	ΔP		7	50	°e
Logic State Width Error	ΔS		5	50	°e
Phase Error	$\Delta \phi$		2	25	°e
Cycle Error	ΔC		20	50	°e
Position Error	$\Delta \theta$		20	50	min. of arc
Index Pulse Width					
1000/1024/1250 CPR	P_0	90	150	360	°e
2000/2048/2500 CPR	P_0	180	300	540	°e

Commutation Characteristics (Channel U, V, W)

Encoding Characteristics over the Recommended Operating Conditions and Mounting Conditions. These characteristics include codewheel contribution. The typical values are average over the full rotation of the codewheel.

Parameter	Symbol	Minimum	Maximum	Units
Commutation Format		Three Phase 4, 6, or 8 poles		
Commutation Accuracy (Middle of Channel I to Channel U)	ΔI	-1	+1	°mechanical
Commutation Accuracy (Channel U, V and W)	ΔUVW	-2	+2	°mechanical

Device Pinout

Pin #1 start from left side.

Pin	Function
1	U
2	I
3	V
4	W
5	Ground
6	V _{CC}
7	A
8	B

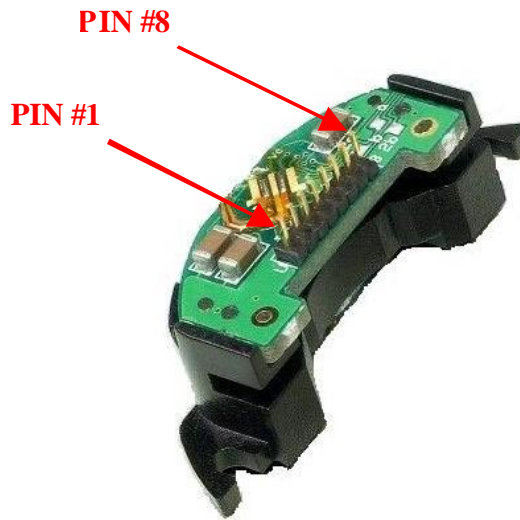

Package Dimensions

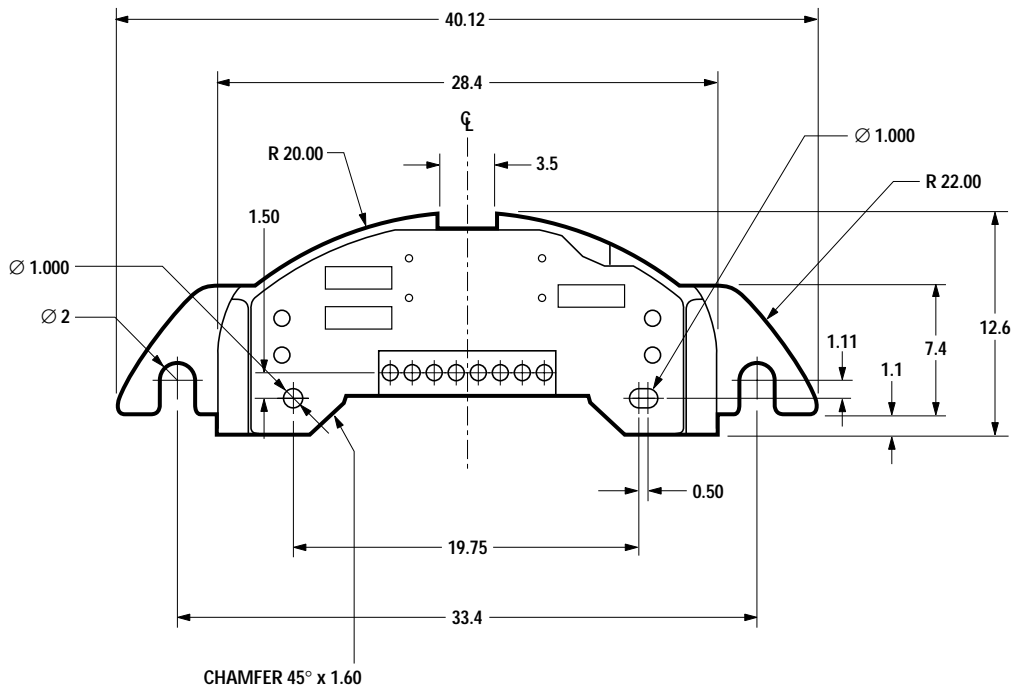

TOP VIEW

Note: All dimensions are given in mm.

Figure 1a. 1000/1024/1250/2000/2048/2500 CPR encoder module dimensions

Package Dimensions, continued

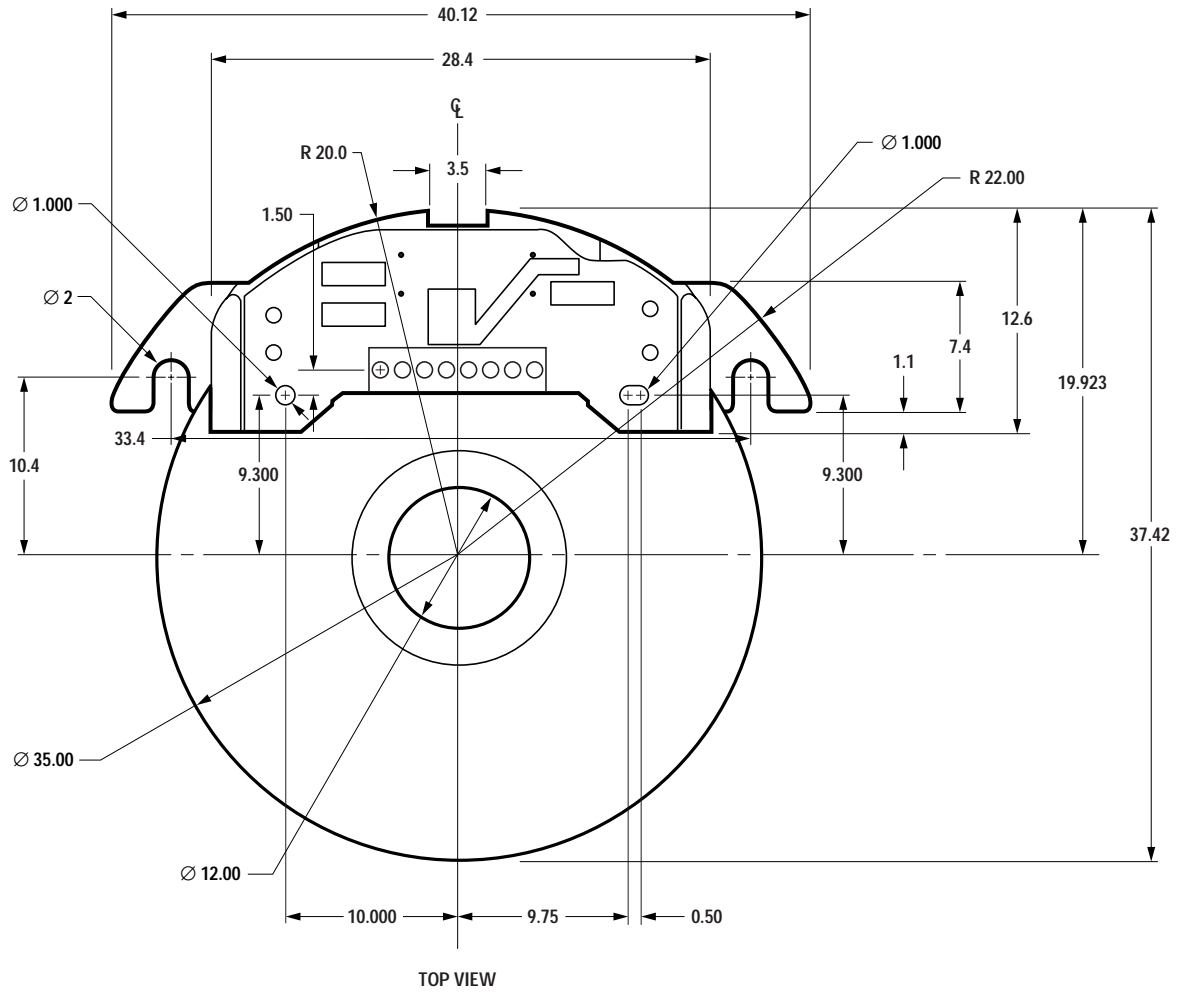

Note: All dimensions are given in mm.

Figure 2a. 1250/2500 CPR encoder module with codewheel dimensions

Mounting Considerations

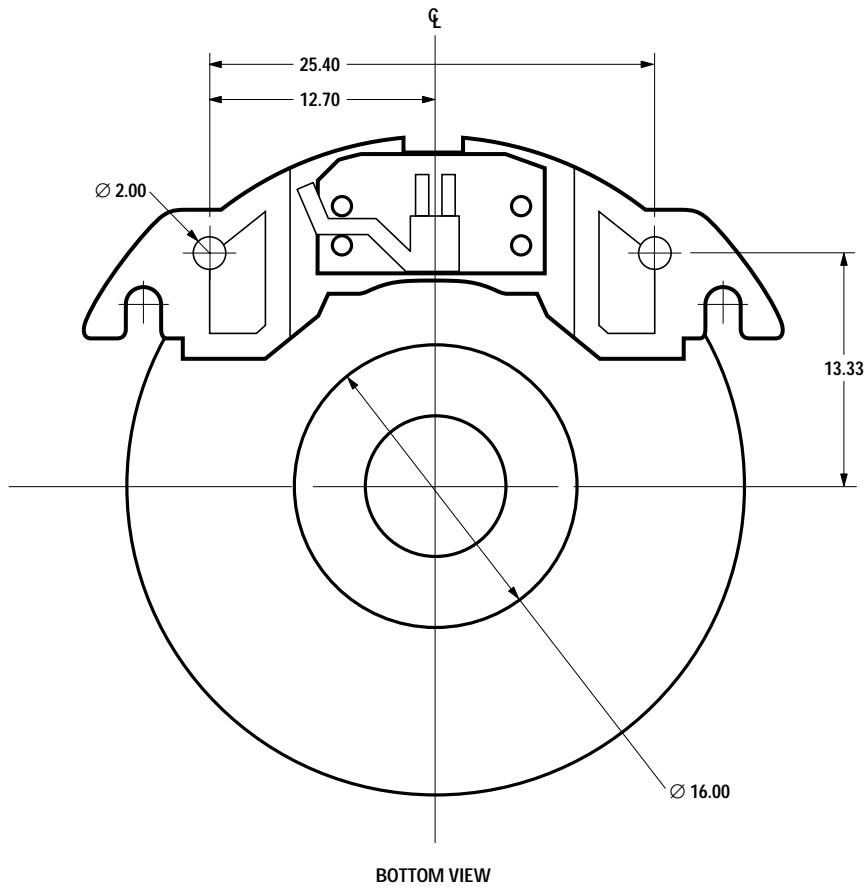

RECOMMENDED SCREW SIZE: M1.6 x 0.35

RECOMMENDED MOUNTING SCREW TORQUE: 1Lbin (0.113 Nm)

NOTES:

1. ALL DIMENSIONS ARE GIVEN IN mm.
2. USE ALIGNMENT TOOL HEDS-8952 TO MOUNT THE ENCODER WITH RESPECT TO SHAFT CENTER.
3. REFER TO AEDB-9340 SERIES APPLICATION NOTE FOR STEP BY STEP ALIGNMENT AND INSTALLATION PROCEDURE.

Figure 2b. 1250/2500 CPR encoder mounting considerations

Package Dimensions

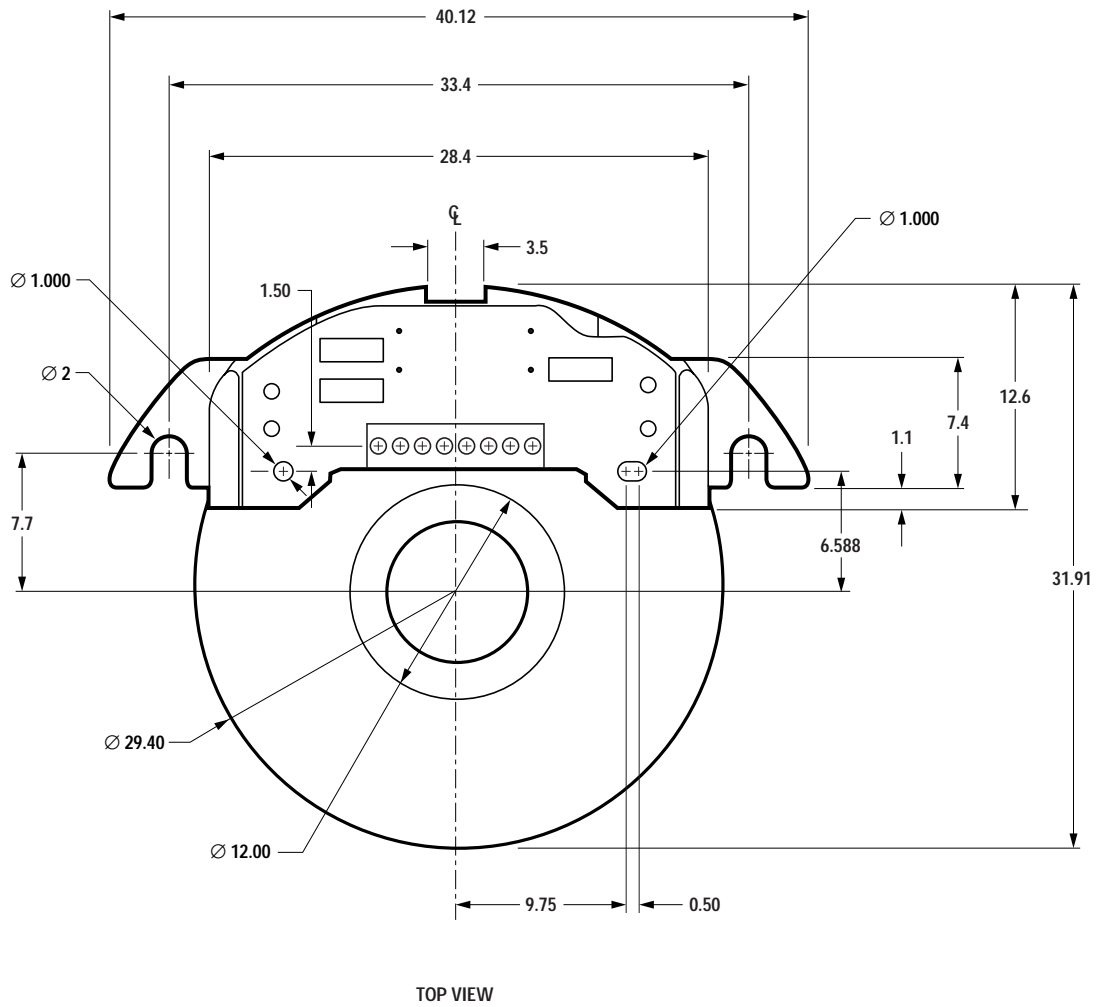

NOTE: ALL DIMENSIONS ARE GIVEN IN mm.

Figure 3a. 1024/2048 CPR encoder module with codewheel dimensions

Mounting Considerations

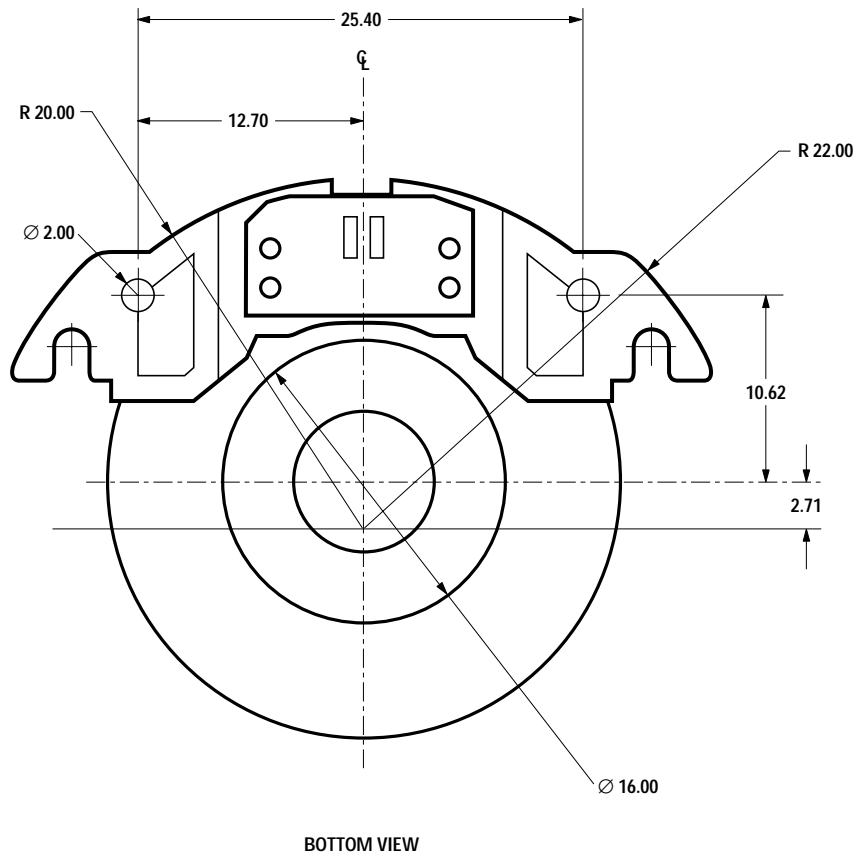

RECOMMENDED SCREW SIZE: M1.6 x 0.35

RECOMMENDED MOUNTING SCREW TORQUE: 1Lbin (0.113 Nm)

NOTES:

1. ALL DIMENSIONS ARE GIVEN IN mm.
2. USE ALIGNMENT TOOL HEDS-8951 TO MOUNT THE ENCODER WITH RESPECT TO SHAFT CENTER.
3. REFER TO AEDB-9340 SERIES APPLICATION NOTE FOR STEP BY STEP ALIGNMENT AND INSTALLATION PROCEDURE.

Figure 3b. 1024/2048 CPR encoder mounting considerations

Mounting Considerations

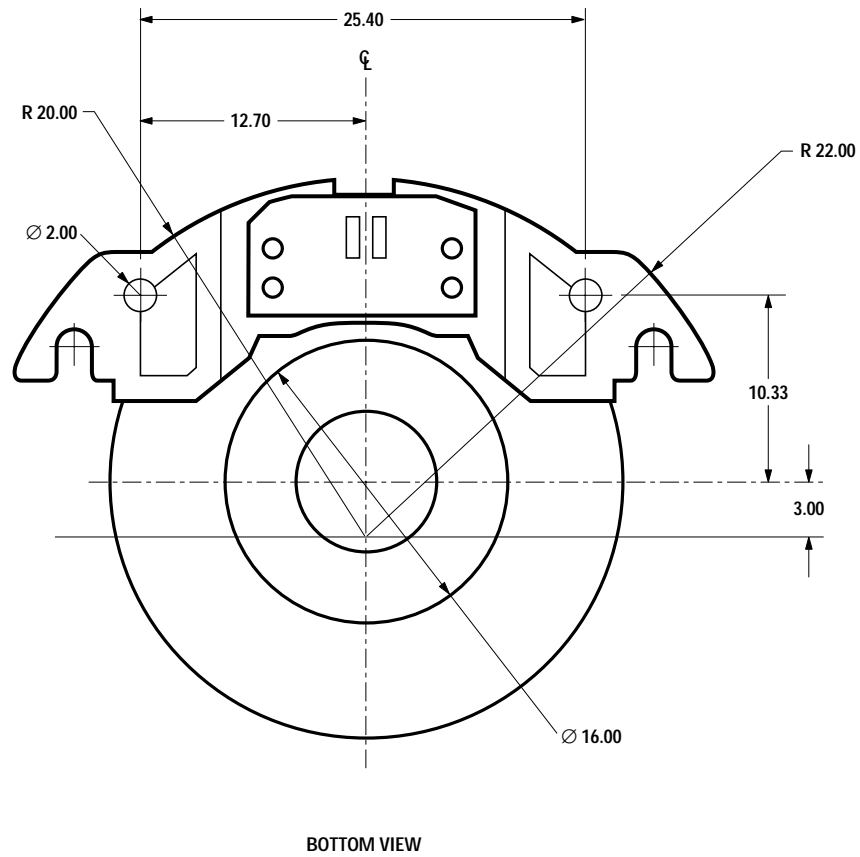

RECOMMENDED SCREW SIZE: M1.6 x 0.35

RECOMMENDED MOUNTING SCREW TORQUE: 1Lbin (0.113 Nm)

NOTES:

1. ALL DIMENSIONS ARE GIVEN IN mm.
2. USE ALIGNMENT TOOL HEDS-8950 TO MOUNT THE ENCODER WITH RESPECT TO SHAFT CENTER.
3. REFER TO AEDB-9340 SERIES APPLICATION NOTE FOR STEP BY STEP ALIGNMENT AND INSTALLATION PROCEDURE.

Figure 4b. 1000/2000 CPR encoder module mounting considerations

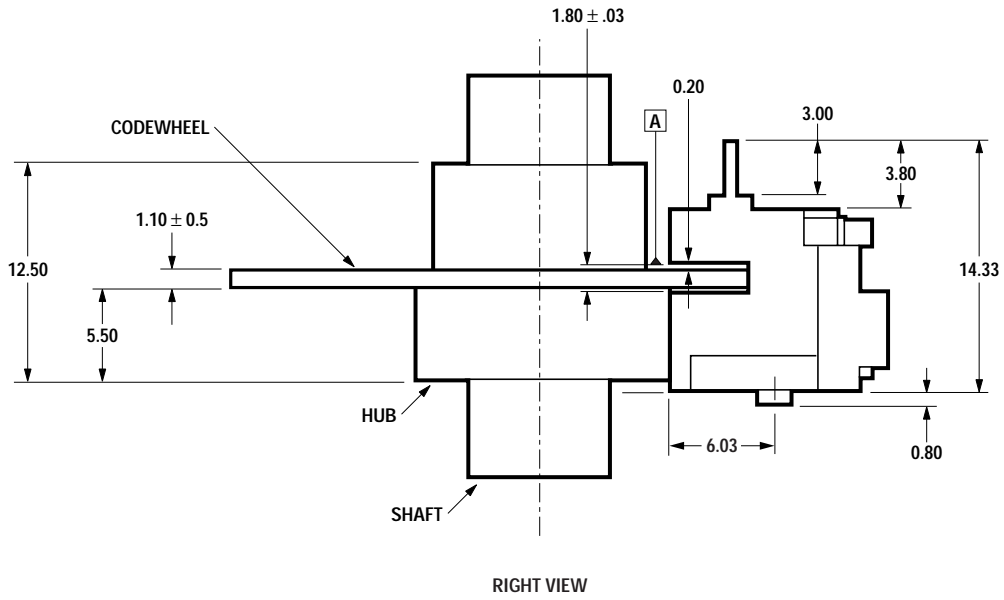

- NOTES:
1. ALL DIMENSIONS ARE GIVEN IN mm.
 2. CODEWHEEL GAP IS ALIGNED AT 0.2 mm FROM DATUM A.

Figure 5. 1000/1024/1250/2000/2048/2500 CPR encoder module and codewheel mounting considerations

Codewheel Mechanical Drawing

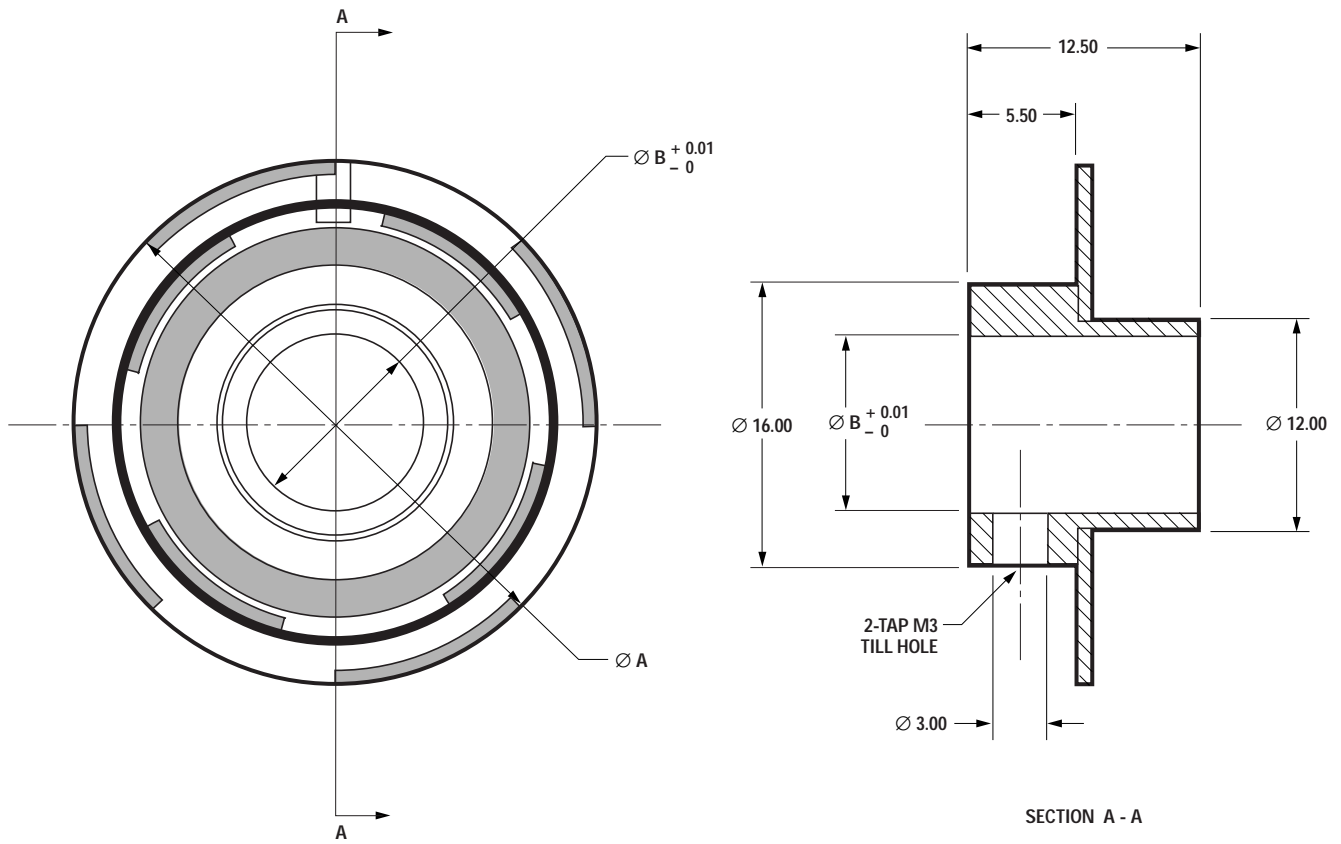

NOTES:
 ALL DIMENSIONS ARE GIVEN IN MILLIMETERS (mm).
 $\varnothing B$ = HUB INTERNAL DIAMETER (BASED ON THE SHAFT DIAMETER OPTION SELECTED).
 $\varnothing A$ = CODEWHEEL OUTER DIAMETER.

CODEWHEEL CPR	OUTER DIAMETER
1250/2500	35 mm
1024/2048	29.4 mm
1000/2000	29 mm

Figure 6. Codewheel and hub dimensions

Output Waveform Specifications

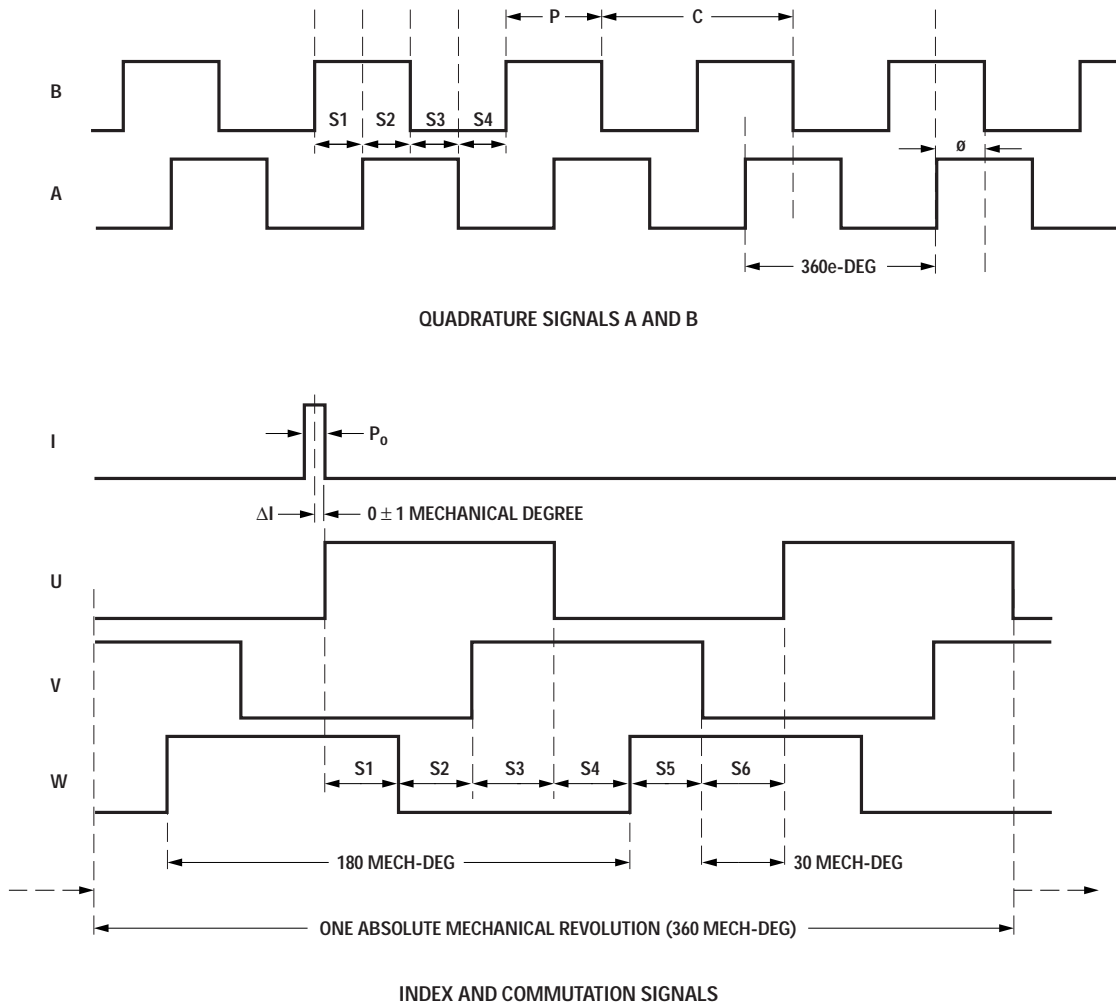

Figure 7. Output waveform specification of 2 pole pairs (= 4 poles) for counterclockwise rotation, viewed from the top.

Note: In the above waveform, quadrature signals A,B are not drawn to scale with respect to index pulse and commutation signals.

Pole vs. State Width Table

Pole	Number of States/ Mechanical Revolution	State Width (Mechanical Degree)
4	12	30
6	18	20
8	24	15

Ordering Information

Encoder Bundled with Codewheel

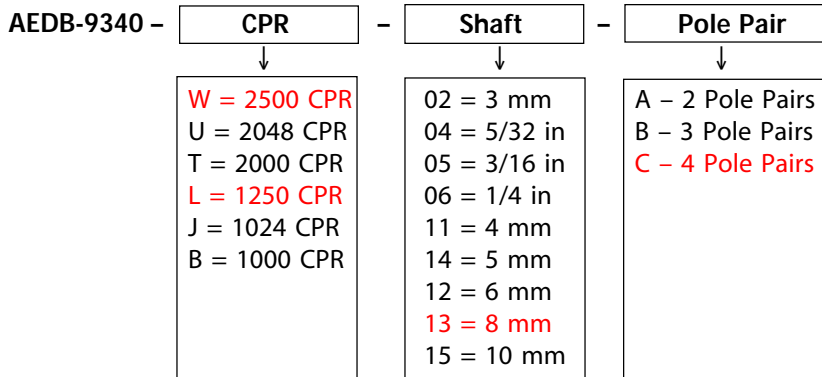

Encoder Only

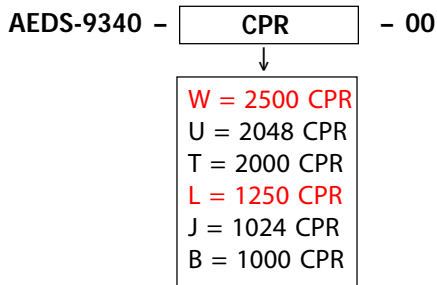

Alignment Tool

HEDS-8950 – Alignment tool for 1000/2000 CPR
HEDS-8951 – Alignment tool for 1024/2048 CPR
HEDS-8952 – Alignment tool for 1250/2500 CPR

Note: Options highlighted in RED are currently available to order.
Contact factory for enquiries on the rest of the options.

For product information and a complete list of distributors, please go to our website: www.avagotech.com

Avago, Avago Technologies, and the A logo are trademarks of Avago Technologies Limited in the United States and other countries.
Data subject to change. Copyright © 2007 Avago Technologies Limited. All rights reserved. Obsoletes AV01-0248EN
AV02-0075EN January 9, 2007

AVAGO
TECHNOLOGIES

Данный компонент на территории Российской Федерации

Вы можете приобрести в компании MosChip.

Для оперативного оформления запроса Вам необходимо перейти по данной ссылке:

<http://moschip.ru/get-element>

Вы можете разместить у нас заказ для любого Вашего проекта, будь то серийное производство или разработка единичного прибора.

В нашем ассортименте представлены ведущие мировые производители активных и пассивных электронных компонентов.

Нашей специализацией является поставка электронной компонентной базы двойного назначения, продукции таких производителей как XILINX, Intel (ex.ALTERA), Vicor, Microchip, Texas Instruments, Analog Devices, Mini-Circuits, Amphenol, Glenair.

Сотрудничество с глобальными дистрибьюторами электронных компонентов, предоставляет возможность заказывать и получать с международных складов практически любой перечень компонентов в оптимальные для Вас сроки.

На всех этапах разработки и производства наши партнеры могут получить квалифицированную поддержку опытных инженеров.

Система менеджмента качества компании отвечает требованиям в соответствии с ГОСТ Р ИСО 9001, ГОСТ РВ 0015-002 и ЭС РД 009

Офис по работе с юридическими лицами:

105318, г.Москва, ул.Щербаковская д.3, офис 1107, 1118, ДЦ «Щербаковский»

Телефон: +7 495 668-12-70 (многоканальный)

Факс: +7 495 668-12-70 (доб.304)

E-mail: info@moschip.ru

Skype отдела продаж:

moschip.ru

moschip.ru_4

moschip.ru_6

moschip.ru_9