

General Description

The MIC2291 is a 1.2MHz Pulse Width Modulation (PWM), boost-switching regulator that is optimized for high-current, white LED photo flash applications. With a guaranteed switch current of 1.2A, the MIC2291 easily drives a string of 3 white LEDs in series at 100mA, ensuring a high level of brightness and eliminating several ballast resistors.

The MIC2291 implements a constant frequency, 1.2MHz PWM control scheme. The high frequency PWM operation saves board space by reducing external component sizes. The added benefit of the constant frequency PWM scheme, in contrast to variable frequency topologies, is much lower noise and input ripple injected back to the battery source.

To optimize efficiency, the feedback voltage is set to only 95mV. This reduces the power dissipation in the current set resistor, and allows the lowest total output voltage, hence minimal current draw from the battery.

The MIC2291 is available with 2 levels of over-voltage protection, 15V, and 34V. This allows designers to choose the smallest possible external components with the appropriate voltage ratings for their applications.

The MIC2291 is available in low-profile, Thin SOT23 5-pin and 8-pin 2mm x 2mm MLF[®] package options. The MIC2291 has a junction temperature range of -40°C to +125°C.

Data sheets and support documentation can be found on Micrel's web site at www.micrel.com.

Features

- 2.5V to 10V input voltage
- Output voltage up to 34V
- 1.2A switch current
- 1.2MHz PWM operation
- 95mV feedback voltage
- Overvoltage protection (OVP)
 - Options for 15V and 34V
- Stable with ceramic capacitors
- <1% line and load regulation
- 1µA shutdown current
- Over temperature protection
- UVLO
- Low-profile Thin SOT23-5 package option
- 2mm x 2mm MLF[®] package option
- -40°C to +125°C junction temperature range

Applications

- Photo Flash LED driver
- Cell phones
- PDAs
- GPS systems
- Digital cameras
- IP phones
- LED flashlights

Typical Application

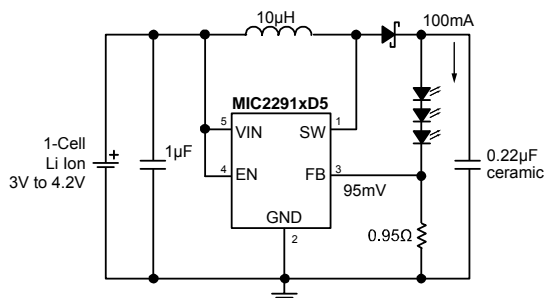

Thin SOT23 Flash LED Driver

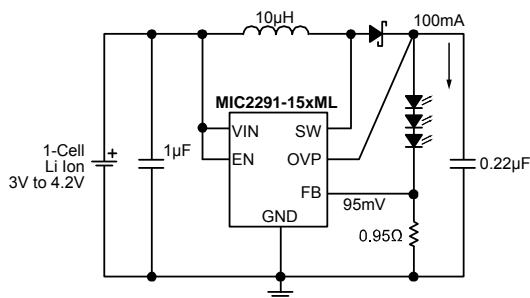

2mm x 2mm Flash LED Driver with Output OVP

PowerPAK is a trademark of Siliconix, Inc.

MLF and MicroLeadFrame are registered trademarks of Amkor Technology, Inc.

Micrel Inc. • 2180 Fortune Drive • San Jose, CA 95131 • USA • tel +1 (408) 944-0800 • fax + 1 (408) 474-1000 • <http://www.micrel.com>

Ordering Information

Part Number	Marking*	Overshoot Protection	Junction Temp. Range	Package	Lead Finish
MIC2291BD5	SSAA	—	−40° to +125°C	5-Pin Thin SOT23	Standard
MIC2291YD5	<u>SSAA</u>	—	−40° to +125°C	5-Pin Thin SOT23	Pb-Free
MIC2291-15BML	STA	15	−40° to +125°C	8-Pin 2mm x 2mm MLF®	Standard
MIC2291-15YML	<u>STA</u> **	15	−40° to +125°C	8-Pin 2mm x 2mm MLF®	Pb-Free
MIC2291-34BML	STC	34	−40° to +125°C	8-Pin 2mm x 2mm MLF®	Standard
MIC2291-34YML	<u>STC</u> **	34	−40° to +125°C	8-Pin 2mm x 2mm MLF®	Pb-Free

Notes:

* Under bar / Over bar symbol may not be to scale.

** Over bar symbol located after Pin 1 identifier.

Pin Configuration

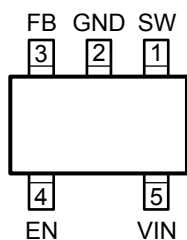

5-Pin TSOT23 (D5)

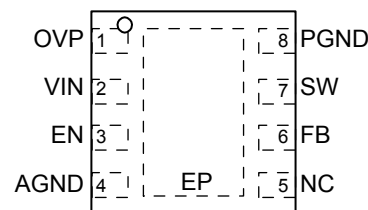

8-Pin 2mm x 2mm MLF® (ML)

Pin Description

Pin Number TSOT23-5	Pin Number 2x2 MLF-8	Pin Name	Pin Name
1	7	SW	Switch node (Output): Internal power BIPOLAR collector.
2		GND	Ground (Return): Ground.
3	6	FB	Feedback (Input): Output voltage sense node. Connect the cathode of the LED to this pin. Connect current set resistor from this pin to ground.
4	3	EN	Enable (Input): Logic high ($\geq 1.5V$) enables regulator. Logic low ($\leq 0.4V$) shuts down regulator.
5	2	VIN	Supply (Input): Input Voltage.
—	1	OVP	Overshoot protection (Input): Connect to the output to clamp the maximum output voltage.
—	4	AGND	Analog ground. Internally connected to ground.
—	8	PGND	Power ground.
—	5	NC	No connect (no internal connection to die).
—	EP	GND	Ground (Return): Exposed backside pad.

Absolute Maximum Ratings⁽¹⁾

Supply Voltage (V_{IN})	12V
Switch Voltage (V_{SW})	-0.3V to 34V
Enable Pin Voltage (V_{EN})	-0.3V to V_{IN}
FB Voltage (V_{FB})	6V
Switch Current (I_{SW})	2A
Storage Temperature (T_s)	-65°C to +150°C
ESD Rating ⁽³⁾	2kV

Operating Ratings⁽²⁾

Supply Voltage (V_{IN})	2.5V to 10V
Junction Temperature (T_J)	-40°C to +125°C
Package Thermal Resistance	
2x2 MLF-8 (θ_{JA})	93°C/W
Thin SOT23-5 (θ_{JA})	256°C/W

Electrical Characteristics⁽⁴⁾

$T_A = 25^\circ\text{C}$, $V_{IN} = V_{EN} = 3.6\text{V}$; $V_{OUT} = 10\text{V}$; $I_{OUT} = 40\text{mA}$, **bold** values indicate $-40^\circ\text{C} \leq T_J \leq +125^\circ\text{C}$, unless noted.

Symbol	Parameter	Condition	Min	Typ	Max	Units
V_{IN}	Supply Voltage Range		2.5		10	V
V_{UVLO}	Under Voltage Lockout		1.8	2.1	2.4	V
I_{VIN}	Quiescent Current	$V_{FB} > 200\text{mV}$, (not switching)		2.8	5	mA
I_{SD}	Shutdown Current	$V_{EN} = 0\text{V}$ (5)		0.1	1	μA
V_{FB}	Feedback Voltage	($\pm 5\%$)	90	95	100	mV
I_{FB}	Feedback Input Current	$V_{FB} = 95\text{mV}$		-450		nA
	Line Regulation(7)	$3\text{V} \leq V_{IN} \leq 5\text{V}$		0.5	1	%
	Load Regulation(7)	$5\text{mA} \leq I_{OUT} \leq 40\text{mA}$		0.5		%
D_{MAX}	Maximum Duty Cycle		85	90		%
I_{SW}	Switch Current Limit			1.2		A
V_{SW}	Switch Saturation Voltage	$I_{SW} = 1.0\text{A}$		550		mV
I_{SW}	Switch Leakage Current	$V_{EN} = 0\text{V}$, $V_{SW} = 10\text{V}$		0.01	5	μA
V_{EN}	Enable Threshold	TURN ON TURN OFF	1.5		0.4	V V
I_{EN}	Enable Pin Current	$V_{EN} = 10\text{V}$ (6)		20	40	μA
f_{SW}	Oscillator Frequency		1.05	1.2	1.35	MHz
V_{OVP}	Overshoot Protection	MIC2291BML- 15 only MIC2291BML- 34 only	13 30	14 32	16 34	V V
T_J	Overtemperature Threshold Shutdown	Hysteresis		150 10		$^\circ\text{C}$ $^\circ\text{C}$

Notes:

- Absolute maximum ratings indicate limits beyond which damage to the component may occur. Electrical specifications do not apply when operating the device outside of its operating ratings. The maximum allowable power dissipation is a function of the maximum junction temperature, $T_{J(max)}$, the junction-to-ambient thermal resistance, θ_{JA} , and the ambient temperature, T_A . The maximum allowable power dissipation will result in excessive die temperature, and the regulator will go into thermal shutdown.
- The device is not guaranteed to function outside its operating rating.
- Devices are ESD sensitive. Handling precautions recommended. Human body model.
- Specification for packaged product only.
- $I_{SD} = I_{VIN}$.
- See "Typical Characteristics" section for other V_{EN} .
- Guaranteed by design.

Typical Characteristics

Efficiency 12V_{OUT}

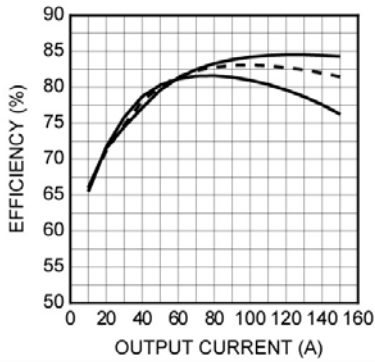

Feedback Voltage vs. Temperature

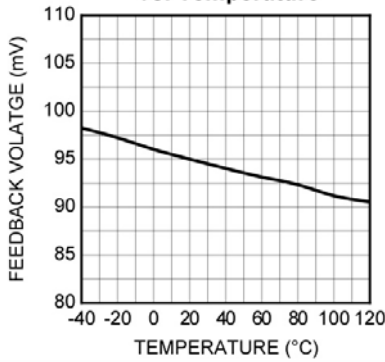

Current Limit vs. Supply Voltage

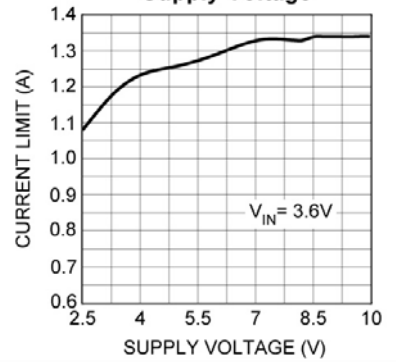

Current Limit vs. Temperature

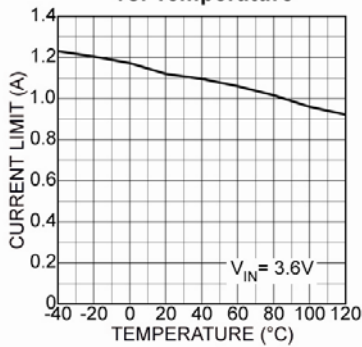

Current Limit vs. Temperature

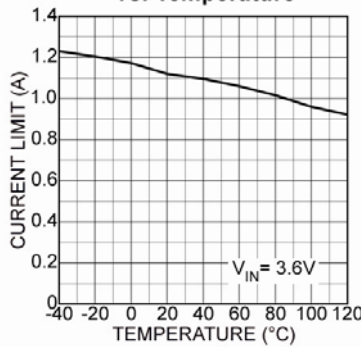

Saturation Voltage vs. Current

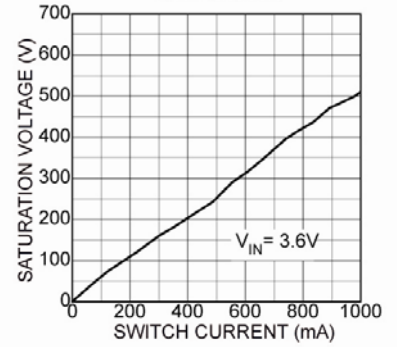

Switch Saturation vs. Temperature

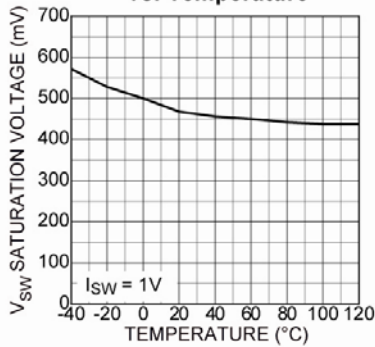

Frequency vs. Temperature

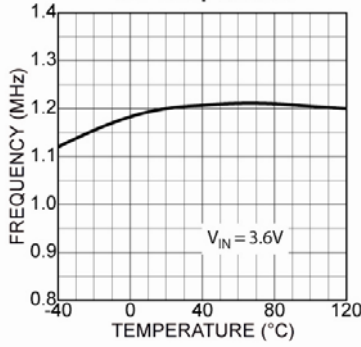

Maximum Duty Cycle vs. Supply Voltage

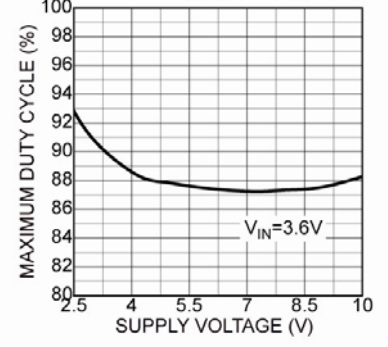

Maximum Duty Cycle vs. Temperature

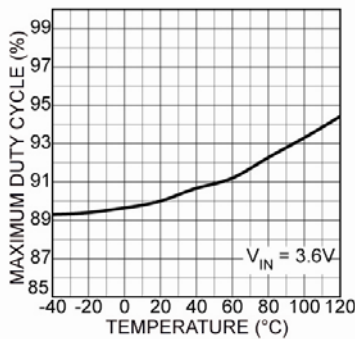

Maximum Duty Cycle vs. Temperature

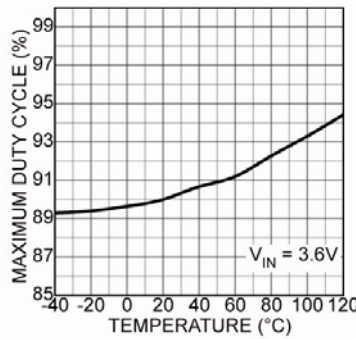

Enable Threshold vs. Supply Voltage

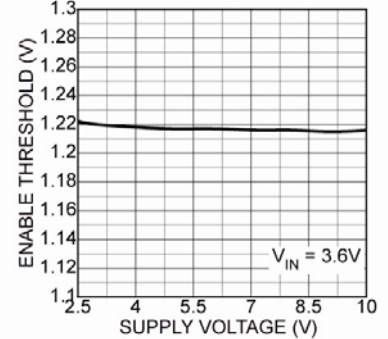

Functional Characteristics

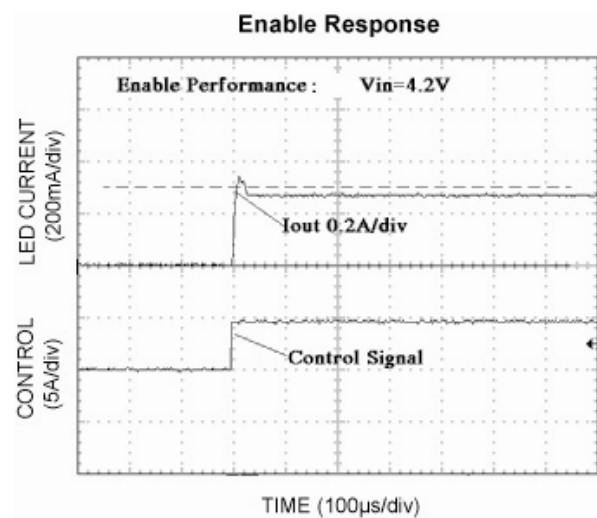
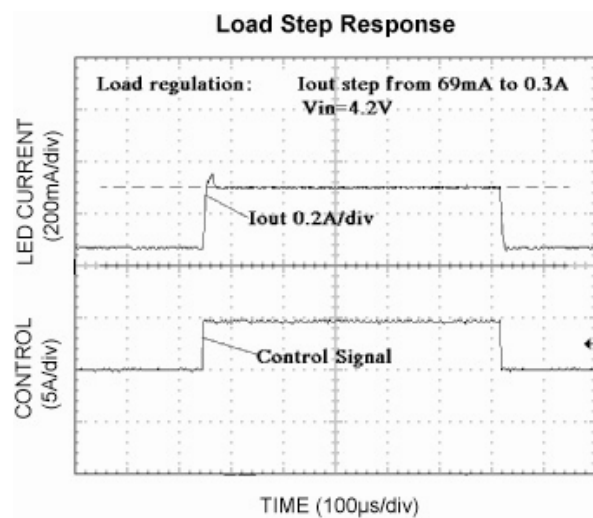
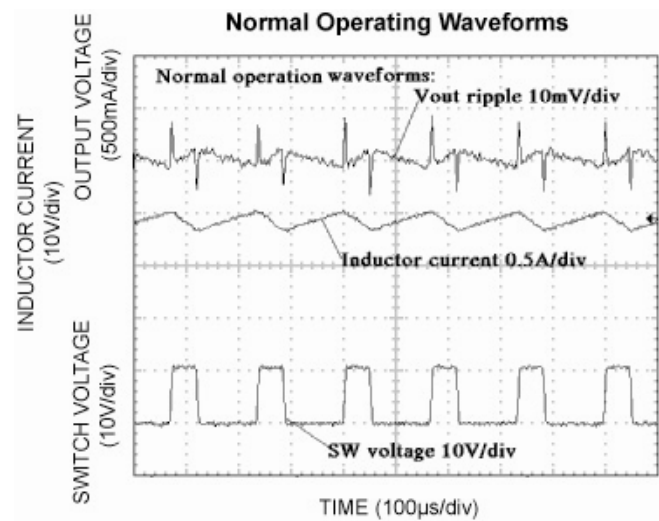
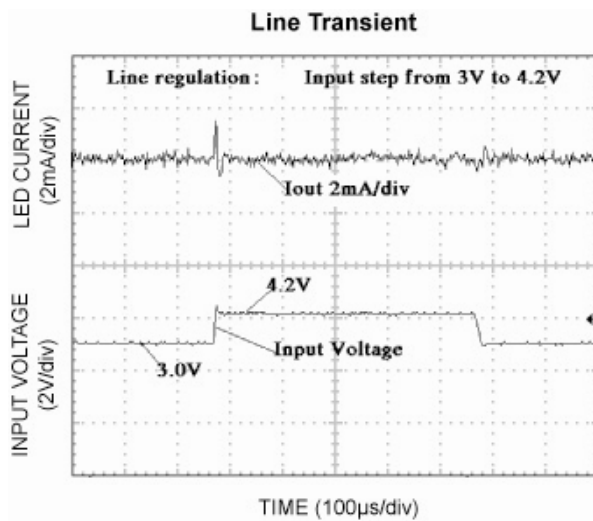

Functional Diagram

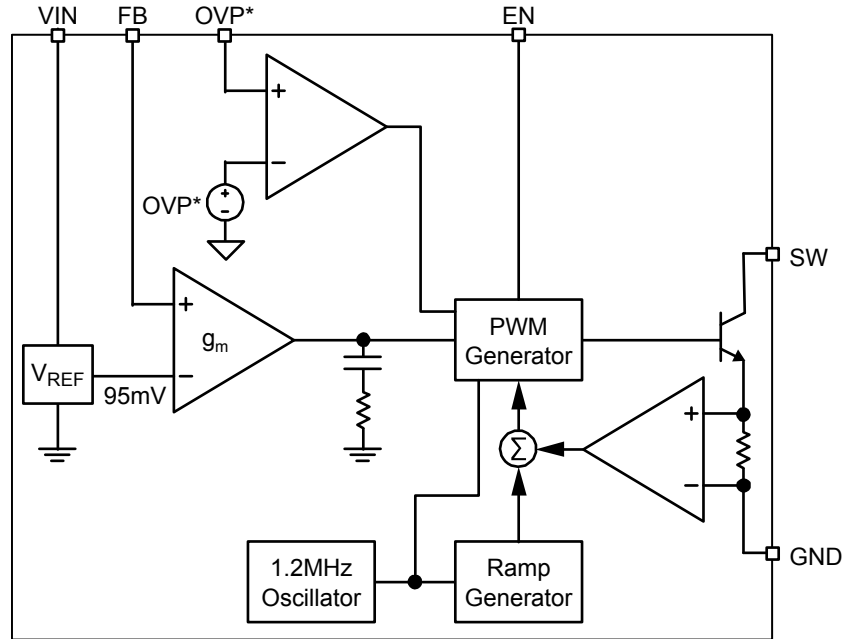

*OVP available on MLF® package option only

Figure 1. MIC2291 Block Diagram

Functional Description

The MIC2291 is a constant frequency, PWM current mode boost regulator. The block diagram is shown above. The MIC2291 is composed of an oscillator, slope compensation ramp generator, current amplifier, g_m error amplifier, PWM generator, and a 500mA bipolar output transistor. The oscillator generates a 1.2MHz clock. The clock's two functions are to trigger the PWM generator that turns on the output transistor and to reset the slope compensation ramp generator. The current amplifier is used to measure the switch current by amplifying the voltage signal from the internal sense resistor. The output of the current amplifier is summed with the output of the slope compensation ramp generator. This summed current-loop signal is fed to one of the inputs of the PWM generator.

The g_m error amplifier measures the LED current through the external sense resistor and amplifies the error between the detected signal and the 95mV reference voltage. The output of the g_m error amplifier provides the voltage-loop signal that is fed to the other input of the PWM generator. When the current-loop signal exceeds the voltage-loop signal, the PWM generator turns off the bipolar output transistor. The next clock period initiates the next switching cycle, maintaining the constant frequency current-mode PWM control. The LED is set by the feedback resistor:

$$I_{LED} = \frac{95mV}{R_{FB}}$$

The Enable pin shuts down the output switching and disables control circuitry to reduce input current-to-leakage levels. Enable pin input current is zero at zero volts.

Application Information

DC to DC PWM Boost Conversion

The MIC2291 is a constant frequency boost converter. It operates by taking a DC input voltage and regulating current through series LED's by monitoring voltage across the sense resistor (R2). LED current regulation is achieved by turning on an internal switch, which draws current through the inductor (L1). When the switch turns off, the inductor's magnetic field collapses, causing the current to be discharged into the output capacitor through an external schottkey diode (D1). Regulation is then achieved by pulse width modulation (PWM) to maintain a constant voltage on the FB pin. This in turn provides constant LED current.

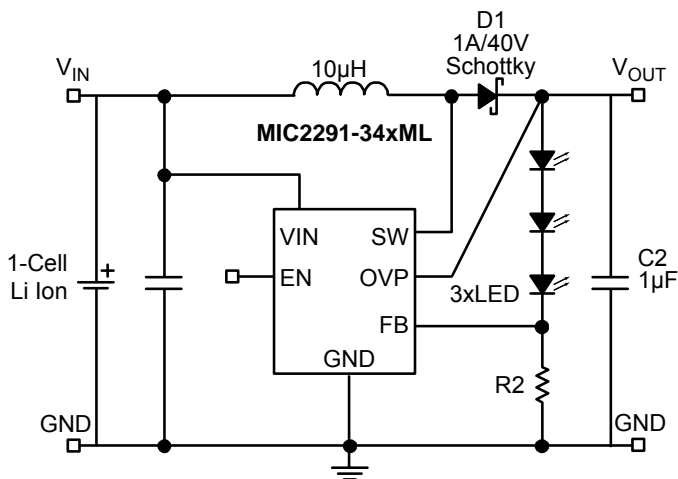

Figure 2. DC to DC PWM Boost Conversion

Duty Cycle Considerations

Duty cycle refers to the switch on-to-off time ratio and can be calculated as follows for a boost regulator;

$$D = 1 - \frac{V_{IN}}{V_{OUT}}$$

The duty cycle required for voltage conversion should be less than the maximum duty cycle of 85%. Also, in light load conditions where the input voltage is close to the output voltage, the minimum duty cycle can cause pulse skipping. This is due to the energy stored in the inductor causing the output to overshoot slightly over the regulated output voltage. During the next cycle, the error amplifier detects the output as being high and skips the following pulse. This effect can be reduced by increasing the minimum load or by increasing the inductor value. Increasing the inductor value reduces peak current, which in turn reduces energy transfer in each cycle.

Over Voltage Protection

For MFLF[®] package of MIC2291, there is an over voltage protection function. If the feedback resistors are disconnected from the circuit or the feedback pin is shorted to ground, the feedback pin will fall to ground potential. This will cause the MIC2291 to switch at full duty-cycle in an attempt to maintain the feedback voltage. As a result the output voltage will climb out of control. This may cause the switch node voltage to exceed its maximum voltage rating, possibly damaging the IC and the external components. To ensure the highest level of protection, the MIC2291 OVP pin will shut the switch off when an over-voltage condition is detected saving itself and other sensitive circuitry downstream.

Component Selection

Inductor

Inductor selection is a balance between efficiency, stability, cost, size and rated current. For most applications a 10µH is the recommended inductor value. It is usually a good balance between these considerations.

Efficiency is affected by inductance value in that larger inductance values reduce the peak to peak ripple current. This has an effect of reducing both the DC losses and the transition losses. There is also a secondary effect of an inductor's DC resistance (DCR). The DCR of an inductor will be higher for more inductance in the same package size. This is due to the longer windings required for an increase in inductance. Since the majority of input current (minus the MIC2291 operating current) is passed through the inductor, higher DCR inductors will reduce efficiency.

Also, to maintain stability, increasing inductor size will have to be met with an increase in output capacitance. This is due to the unavoidable "right half plane zero" effect for the continuous current boost converter topology. The frequency at which the right half plane zero occurs can be calculated as follows;

$$f_{rhpz} = \frac{V_{IN}^2}{V_{OUT} \times L \times I_{OUT} \times 2\pi}$$

The right half plane zero has the undesirable effect of increasing gain, while decreasing phase. This requires that the loop gain is rolled off before this has significant effect on the total loop response. This can be accomplished by either reducing inductance (increasing RHPZ frequency) or increasing the output capacitor value (decreasing loop gain).

Output Capacitor

A 1µF or greater output capacitor is sufficient for most designs. An X5R or X7R dielectric ceramic capacitors are recommended for designs with the MIC2291. Y5V values may be used, but to offset their tolerance over temperature, more capacitance is required.

Diode Selection

The MIC2291 requires an external diode for operation. A schottkey diode is recommended for most applications due to their lower forward voltage drop and reverse recovery time. Ensure the diode selected can deliver the peak inductor current, the maximum output current and the maximum reverse voltage is rated greater than the output voltage.

Input Capacitor

A minimum 1µF ceramic capacitor is recommended for designing with the MIC2291. Increasing input capacitance will improve performance and greater noise immunity on the source. The input capacitor should be as close as possible to the inductor and the MIC2291, with short traces for good noise performance.

Feedback Resistors

The MIC2291 utilizes a feedback pin to compare the output to an internal reference. The LED current is adjusted by selecting the appropriate feedback resistor value. The desired current can be calculated as follows;

$$R2 = \frac{V_{REF}}{I_{LED}}$$

Where VREF is equal to 95mV.

Dimming Control

There are two techniques for dimming control. One is PWM dimming, and the other is continuous dimming.

1. PWM dimming control is implemented by applying a PWM signal on EN pin as shown in Figure 1. The MIC2291 is turned on and off by the PWM signal. With this method, the LEDs operate with either zero or full current. The average LED current is increased proportionally to the duty-cycle of the PWM signal. This technique has high-efficiency because the IC and the LEDs consume no current during the off cycle of the PWM signal. Typical PWM frequency should be between 100Hz and 10kHz.

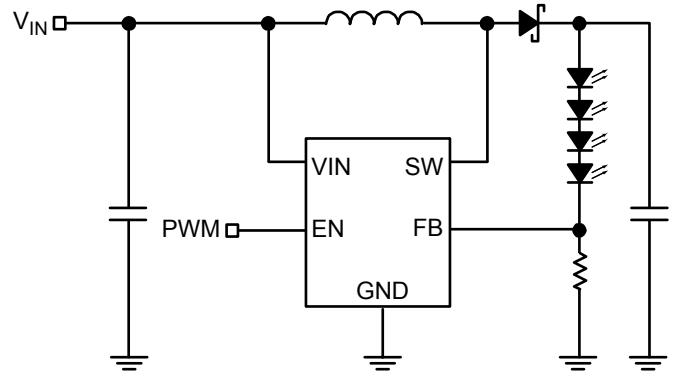

Figure 3. PWM Dimming Method

2. Continuous dimming control is implemented by applying a DC control voltage to the FB pin of the MIC2291 through a series resistor as shown in Figure 2. The LED intensity (current) can be dynamically varied applying a DC voltage to the FB pin. The DC voltage can come from a DAC signal, or a filtered PWM signal. The advantage of this approach is that a high frequency PWM signal (>10kHz) can be used to control LED intensity.

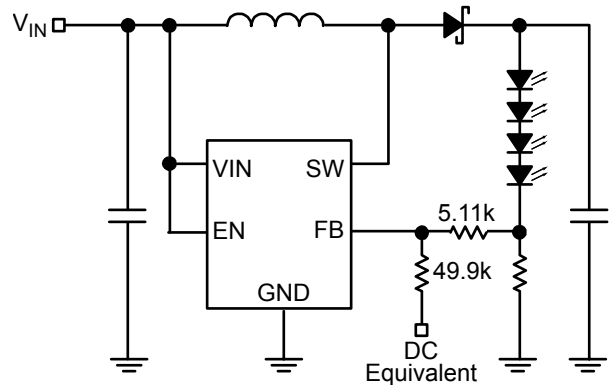
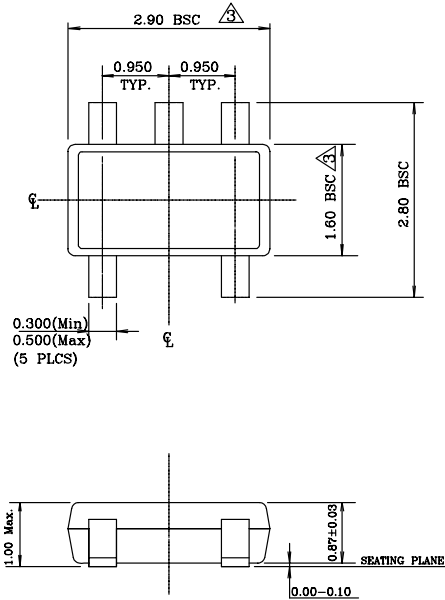

Figure 4. Continuous Dimming

Package Information



NOTE:

1. Dimensions and tolerances are as per ANSI Y14.5M, 1994.
2. Die is facing up for mold. Die is facing down for trim/form, ie. reverse trim/form.
- △ Dimensions are exclusive of mold flash and gate burr.
4. The footlength measuring is based on the gauge plane method.
5. All specification comply to Jedec Spec M0193 Issue C.
6. All dimensions are in millimeters.

5-Pin Thin SOT23 (D5)

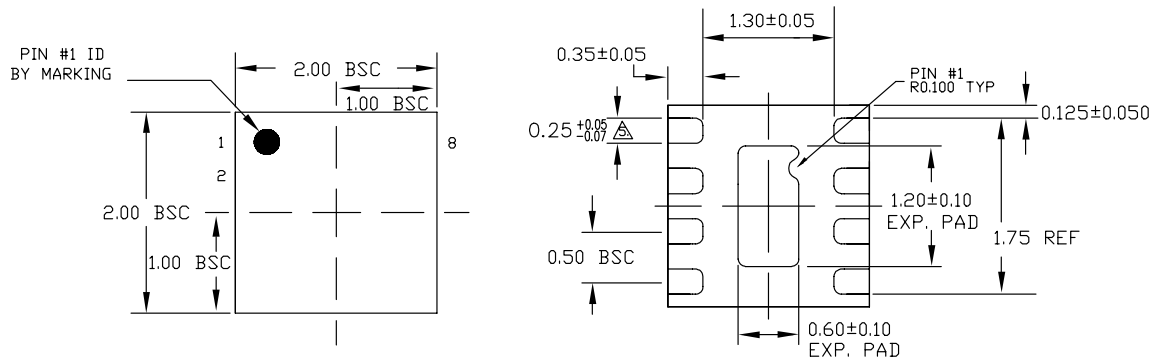

TOP VIEW

BOTTOM VIEW

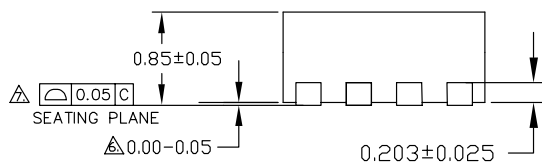

SIDE VIEW

NOTE:

1. ALL DIMENSIONS ARE IN MILLIMETERS.
2. MAX. PACKAGE WARPAGE IS 0.05 mm.
3. MAXIMUM ALLOWABLE BURRS IS 0.076 mm IN ALL DIRECTIONS.
4. PIN #1 ID ON TOP WILL BE LASER/INK MARKED.
- △ DIMENSION APPLIES TO METALIZED TERMINAL AND IS MEASURED BETWEEN 0.20 AND 0.25 mm FROM TERMINAL TIP.
- △ APPLIED ONLY FOR TERMINALS.
- △ APPLIED FOR EXPOSED PAD AND TERMINALS.

8-Pin 2mm x 2mm MLF® (ML)

MICREL, INC. 2180 FORTUNE DRIVE SAN JOSE, CA 95131 USA
TEL +1 (408) 944-0800 FAX +1 (408) 474-1000 WEB <http://www.micrel.com>

The information furnished by Micrel in this data sheet is believed to be accurate and reliable. However, no responsibility is assumed by Micrel for its use. Micrel reserves the right to change circuitry and specifications at any time without notification to the customer.

Micrel Products are not designed or authorized for use as components in life support appliances, devices or systems where malfunction of a product can reasonably be expected to result in personal injury. Life support devices or systems are devices or systems that (a) are intended for surgical implant into the body or (b) support or sustain life, and whose failure to perform can be reasonably expected to result in a significant injury to the user. A Purchaser's use or sale of Micrel Products for use in life support appliances, devices or systems is a Purchaser's own risk and Purchaser agrees to fully indemnify Micrel for any damages resulting from such use or sale.

© 2004 Micrel, Incorporated.

Данный компонент на территории Российской Федерации

Вы можете приобрести в компании MosChip.

Для оперативного оформления запроса Вам необходимо перейти по данной ссылке:

<http://moschip.ru/get-element>

Вы можете разместить у нас заказ для любого Вашего проекта, будь то серийное производство или разработка единичного прибора.

В нашем ассортименте представлены ведущие мировые производители активных и пассивных электронных компонентов.

Нашей специализацией является поставка электронной компонентной базы двойного назначения, продукции таких производителей как XILINX, Intel (ex.ALTERA), Vicor, Microchip, Texas Instruments, Analog Devices, Mini-Circuits, Amphenol, Glenair.

Сотрудничество с глобальными дистрибьюторами электронных компонентов, предоставляет возможность заказывать и получать с международных складов практически любой перечень компонентов в оптимальные для Вас сроки.

На всех этапах разработки и производства наши партнеры могут получить квалифицированную поддержку опытных инженеров.

Система менеджмента качества компании отвечает требованиям в соответствии с ГОСТ Р ИСО 9001, ГОСТ РВ 0015-002 и ЭС РД 009

Офис по работе с юридическими лицами:

105318, г.Москва, ул.Щербаковская д.3, офис 1107, 1118, ДЦ «Щербаковский»

Телефон: +7 495 668-12-70 (многоканальный)

Факс: +7 495 668-12-70 (доб.304)

E-mail: info@moschip.ru

Skype отдела продаж:

moschip.ru

moschip.ru_4

moschip.ru_6

moschip.ru_9