

RFFM8550Q

5GHz WiFi Switch + LNA Module
Tested in Accordance with AEC-Q100

The RFFM8550Q provides an integrated switch + LNA solution in a single Front End Module (FEM) for automotive WiFi 802.11a/n/ac systems. The ultra-small form factor and integrated matching greatly reduces the number of external components and layout area in the customer applications. This simplifies the total front end solution by reducing the bill of materials, system footprint, and manufacturing cost. The RFFM8550Q integrates a Single Pole 2-Throw (SP2T) switch and a Low Noise Amplifier (LNA) with bypass mode. The device is provided in a 1.5mm x 1.5mm x 0.50mm 8-pin DFN package.



Package: DFN, 8-pin,
1.5mm x 1.5mm x 0.50mm

Features

- SP2T T/R Switch
- LNA with Bypass Mode
- Input and Output Matched to 50Ω
- Wide Voltage Supply Range
- Supports WiFi chipsets with Integrated Power Amplifier (iPA)
- Low Profile Package for Module Designs

Applications

- Automotive WiFi
- WiFi Direct
- Automotive Diagnostics
- WiFi Infotainment
- 5GHz ISM Band Solutions for Automotive

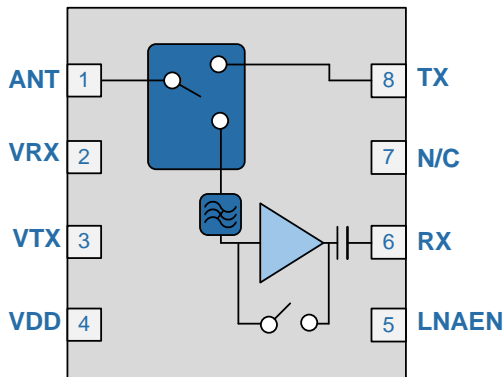

Functional Block Diagram

Ordering Information

RFFM8550QSB	Standard 5-piece sample bag
RFFM8550QSQ	Standard 25-piece sample bag
RFFM8550QSR	Standard 100-piece reel
RFFM8550QTR7	Standard 2500-piece reel
RFFM8550QPCK-410	Fully assembled evaluation board w/ 5-piece bag

RFFM8550Q

Absolute Maximum Ratings

Parameter	Rating	Unit
DC Supply Voltage (No RF Applied)	-0.5 to 6	V
DC Supply Current	100	mA
Operating Case Temperature	-40 to +85	°C
Storage Temperature	-40 to +150	°C
Maximum TX Input Power for 11b/g/n/ac (No Damage)	+30	dBm
Maximum RX Input Power (No Damage)	+12	dBm
Bypass Mode Maximum RX input power (No damage)	+25	dBm
Moisture Sensitivity	MSL1	



Caution! ESD sensitive device.



RFMD Green: RoHS status based on EU Directive 2011/65/EU (at time of this document revision), halogen free per IEC 61249-2-21, < 1000ppm each of antimony trioxide in polymeric materials and red phosphorus as a flame retardant, and <2% antimony in solder.

Exceeding any one or a combination of the Absolute Maximum Rating conditions may cause permanent damage to the device. Extended application of Absolute Maximum Rating conditions to the device may reduce device reliability. Specified typical performance or functional operation of the device under Absolute Maximum Rating conditions is not implied.

Nominal Operating Parameters

Parameter	Specification			Unit	Condition
	Min	Typ	Max		
Compliance:					802.11a / n / ac
Operating Frequency	5.18		5.825	GHz	
Operating Temperature	-40	25	85	°C	
Power Supply V_{DD}	3.0	3.6	5.0	V	
Control Voltage-high	2.8	3.1	V_{CC}	V	VTX, VRX, and LNA_EN Should not exceed V_{CC} voltage
Control Voltage-low		0	0.24	V	
Transmit (TX-ANT)					Over all conditions unless otherwise noted
Insertion Loss		0.6	1.2	dB	Temp = 25°C; V_{DD} = 3.6V; Control Voltage = 3.1V
			0.6	1.8	
TX Port Return Loss	12	25		dB	
ANT Port Return Loss	12	25		dB	
Input P1dB	26	28		dBm	Temp = 25°C; V_{DD} = 3.6V; Control Voltage = 3.1V; CW signal
ANT-RX Isolation	28	35		dB	TX Mode
Receive (ANT-RX)-LNA On					Over all conditions unless otherwise noted
Gain	9	12	14	dB	Temp = 25°C; V_{DD} = 3.6V; Control Voltage = 3.1V
		7	12	16	
Gain flatness	-0.25		+0.25	dB	Over any 80MHz BW; Temp =25°C; V_{DD} =3.6V; Control Voltage=3.1V
Gain flatness across band	-1		+1	dB	Temp = 25°C; V_{DD} = 3.6V; Control Voltage = 3.1V
Noise Figure-Nominal		2.5	3	dB	
			2.5	4.0	dB
Rx Port Return Loss	8	12		dB	
ANT Port Return Loss	8	10		dB	
Input P1dB	-6	-3		dBm	Temp = 25°C; V_{DD} = 3.6V; Control Voltage = 3.1V
Current Consumption	6	12	14	mA	
		4	12	16	mA
LNAEN Control Current		140	250	µA	
LNA Turn On Time		400	600	nS	

RFFM8550Q

Parameter	Specification			Unit	Condition
	Min	Typ	Max		
Receive (ANT-RX)-Bypass Mode					Over all conditions unless otherwise noted
Insertion Loss		7	10	dB	Temp = 25°C; V _{DD} = 3.6V; Control Voltage = 3.1V
		7	13		
RX Port Return Loss	8	12		dB	Temp = 25°C; V _{DD} = 3.6V; Control Voltage = 3.1V
ANT Port Return Loss	8	15		dB	
Input P1dB	15	20		dBm	
General Specifications					
V _{DD} Leakage Current		1	10	μA	
Switch Control Current – High - Each Line		2	10	μA	
Switch Control Current – Low - Each Line		0.2	1	μA	Temp = 25°C; V _{DD} = 3.6V; Control Voltage = 3.1V
Switching Speed		100	500	ns	
ESD – Human Body Model		1000		V	
ESD – Charge Device Model		1000		V	

RFFM8550Q

Switch Control Logic Truth Table

Operating Mode	VTX	LNAEN	VRX
Standby	Low	Low	Low
802.11a/n/ac TX Mode	High	Low	Low
802.11a/n/ac RX Gain	Low	High	High
802.11a/n/ac RX Bypass	Low	Low	High

Note: High = 2.8 to V_{CC} . Low = 0V to 0.2V.

Timing Diagram

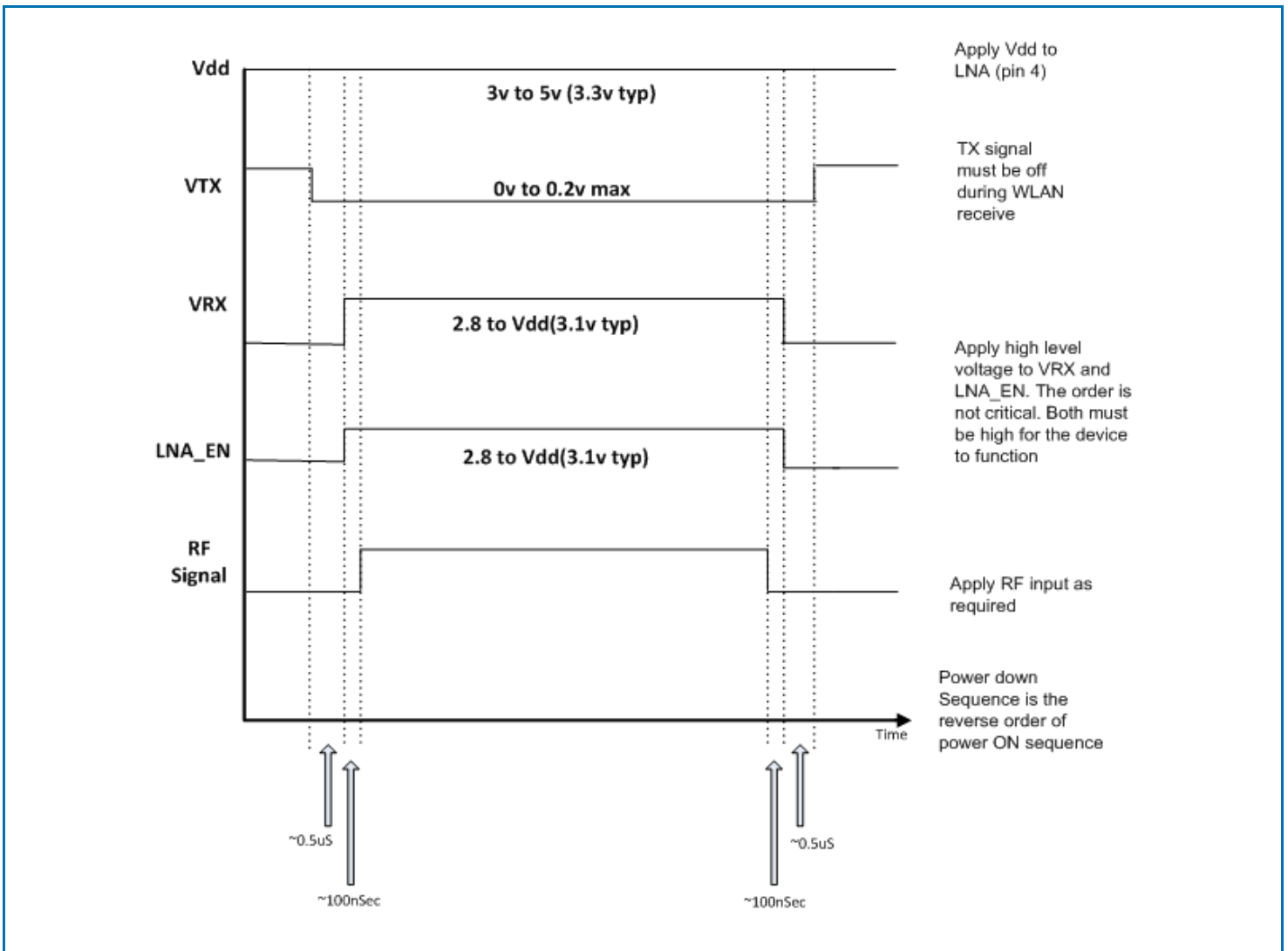

RFFM8550Q

Evaluation Board Schematic

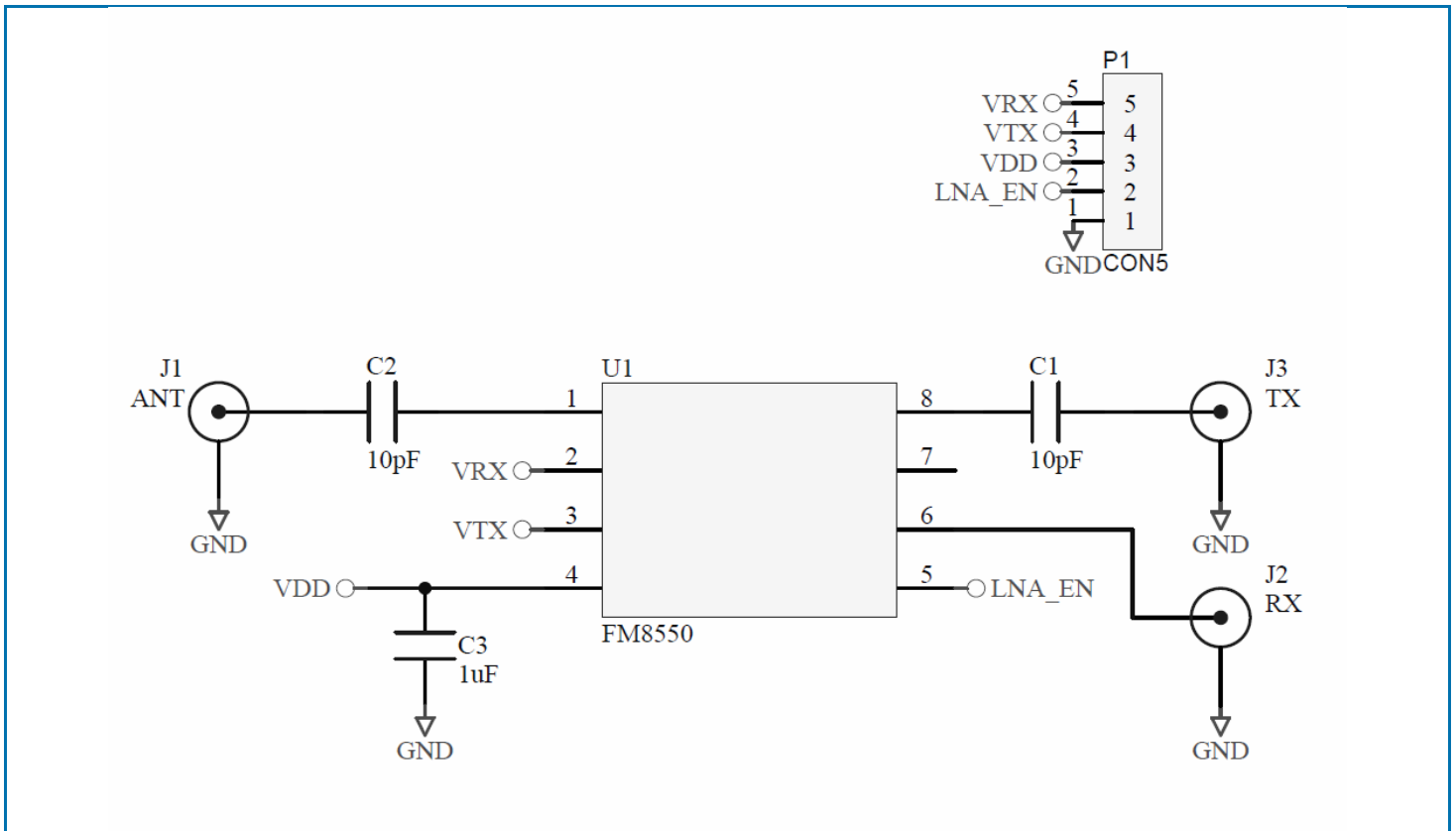

RFFM8550Q

Pin Out

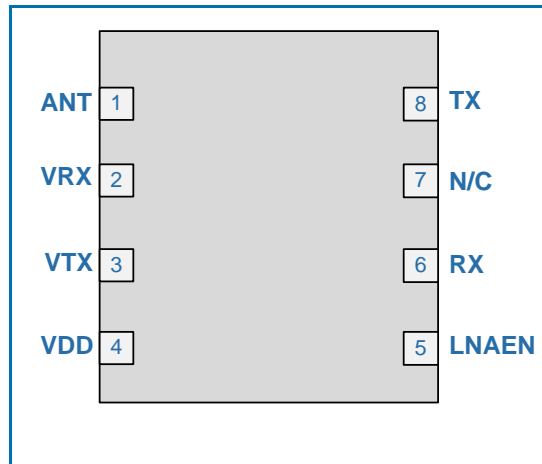

Package Drawing (dimensions in mm)

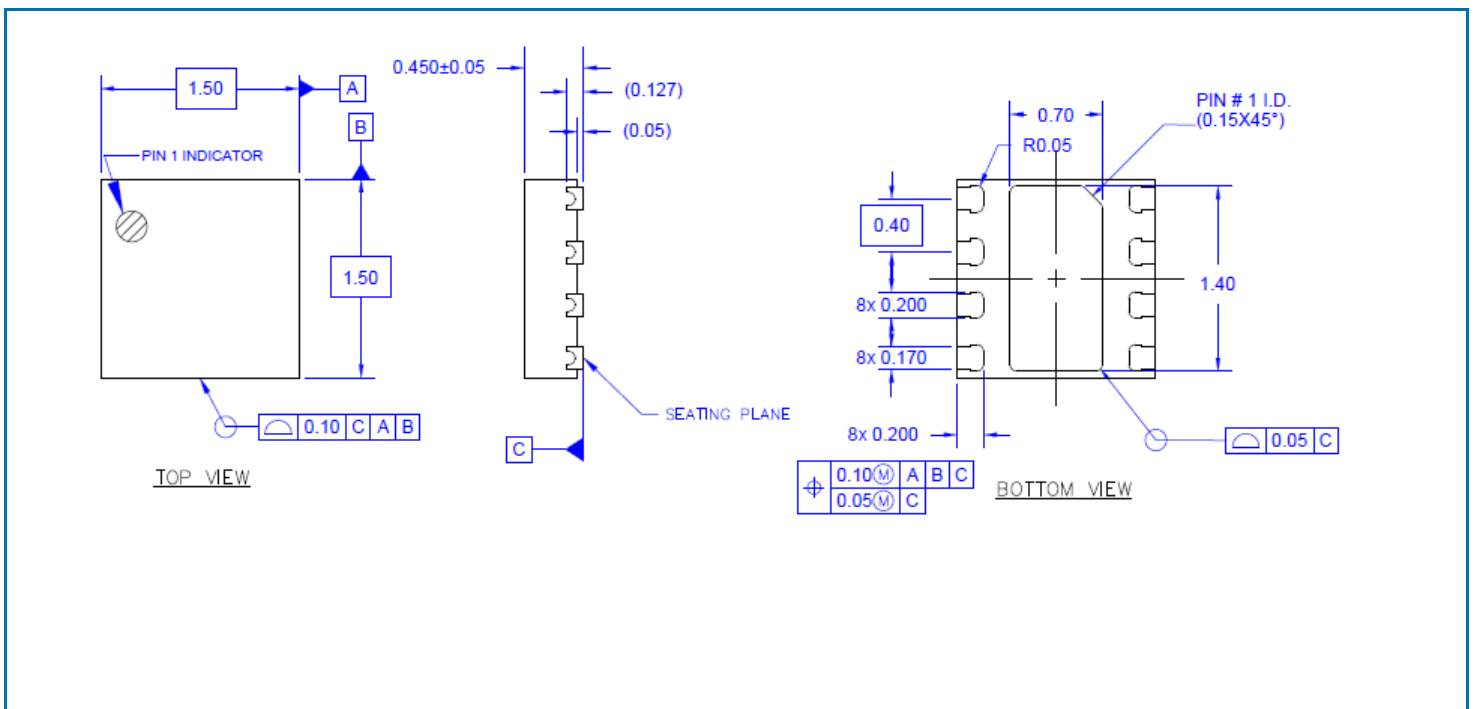

RFFM8550Q

PCB Patterns (dimensions in mm)

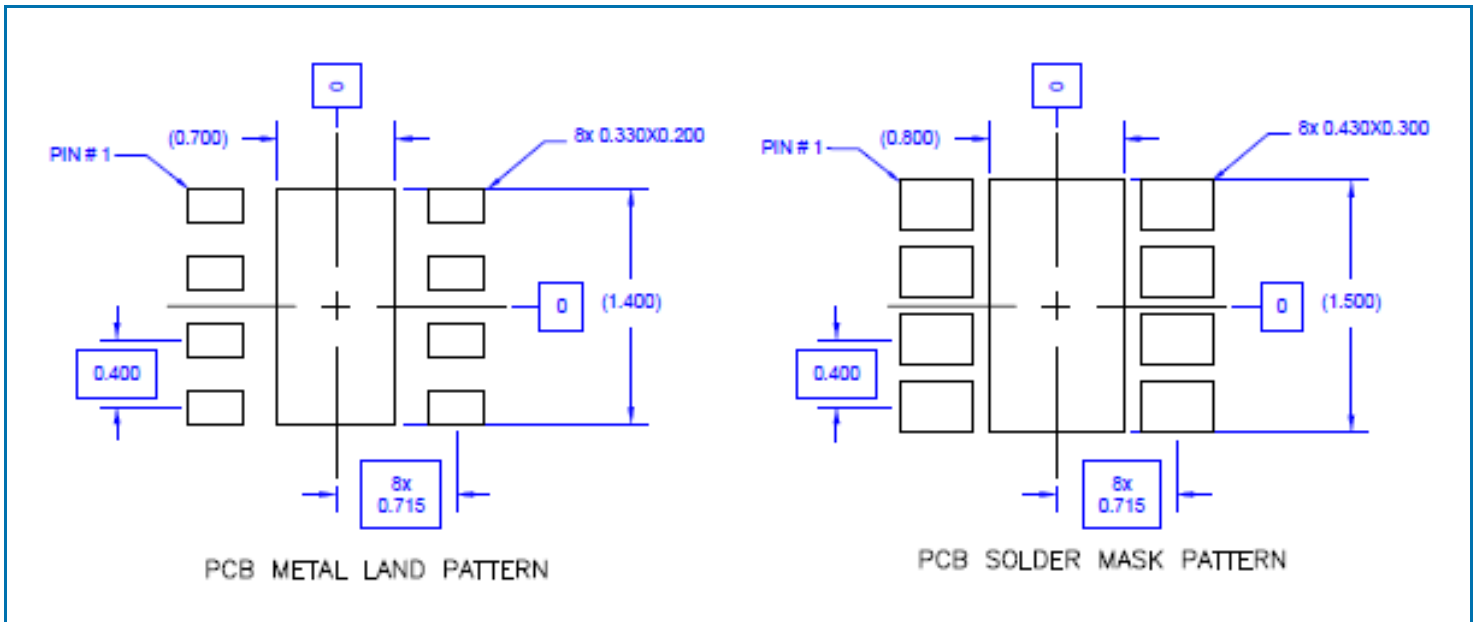

Note: Thermal vias for center slug should be incorporated into the PCB design. The number and size of thermal vias will depend on the application, power dissipation, and electrical requirements. Example of the number and size of vias can be found on the RFMD evaluation board layout (gerber files are available upon request)



RFFM8550Q

Pin Names and Descriptions

Pin	Name	Description
1	ANT	RF bidirectional antenna port matched to 50Ω. An external DC block is required.
2	VRX	Receive switch control pin. See switch truth table for proper voltage level.
3	VTX	Control voltage for the TX switch. See truth table for proper voltage level.
4	VDD	Supply voltage for the LNA. See applications schematic for bypassing components.
5	LNAEN	Control voltage for the LNA. When this pin is set to a LOW logic state, the bypass mode is enabled.
6	RX	RF output port for the 802.11a/n/ac LNA. This port is matched to 50Ω and DC blocked internally
7	N/C	This pin is not connected internally and can be left floating or connected to ground.
8	TX	RF input port for the TX throw of the T/R switch. An external DC block is required
Pkg Base	GND	Ground connection. The backside of the package should be connected to the ground plane through a short path, i.e., PCB vias under the device are recommended.

Contact Information

For the latest specifications, additional product information, worldwide sales and distribution locations:

Web: www.qorvo.com

Tel: 1-844-890-8163

Email: customer.support@qorvo.com

Important Notice

The information contained herein is believed to be reliable; however, Qorvo makes no warranties regarding the information contained herein and assumes no responsibility or liability whatsoever for the use of the information contained herein. All information contained herein is subject to change without notice. Customers should obtain and verify the latest relevant information before placing orders for Qorvo products. The information contained herein or any use of such information does not grant, explicitly or implicitly, to any party any patent rights, licenses, or any other intellectual property rights, whether with regard to such information itself or anything described by such information. **THIS INFORMATION DOES NOT CONSTITUTE A WARRANTY WITH RESPECT TO THE PRODUCTS DESCRIBED HEREIN, AND QORVO HEREBY DISCLAIMS ANY AND ALL WARRANTIES WITH RESPECT TO SUCH PRODUCTS WHETHER EXPRESS OR IMPLIED BY LAW, COURSE OF DEALING, COURSE OF PERFORMANCE, USAGE OF TRADE OR OTHERWISE, INCLUDING THE IMPLIED WARRANTIES OF MERCHANTABILITY AND FITNESS FOR A PARTICULAR PURPOSE.**

Without limiting the generality of the foregoing, Qorvo products are not warranted or authorized for use as critical components in medical, life-saving, or life-sustaining applications, or other applications where a failure would reasonably be expected to cause severe personal injury or death.

Copyright 2016 © Qorvo, Inc. | Qorvo is a registered trademark of Qorvo, Inc.

Данный компонент на территории Российской Федерации

Вы можете приобрести в компании MosChip.

Для оперативного оформления запроса Вам необходимо перейти по данной ссылке:

<http://moschip.ru/get-element>

Вы можете разместить у нас заказ для любого Вашего проекта, будь то серийное производство или разработка единичного прибора.

В нашем ассортименте представлены ведущие мировые производители активных и пассивных электронных компонентов.

Нашей специализацией является поставка электронной компонентной базы двойного назначения, продукции таких производителей как XILINX, Intel (ex.ALTERA), Vicor, Microchip, Texas Instruments, Analog Devices, Mini-Circuits, Amphenol, Glenair.

Сотрудничество с глобальными дистрибьюторами электронных компонентов, предоставляет возможность заказывать и получать с международных складов практически любой перечень компонентов в оптимальные для Вас сроки.

На всех этапах разработки и производства наши партнеры могут получить квалифицированную поддержку опытных инженеров.

Система менеджмента качества компании отвечает требованиям в соответствии с ГОСТ Р ИСО 9001, ГОСТ РВ 0015-002 и ЭС РД 009

Офис по работе с юридическими лицами:

105318, г.Москва, ул.Щербаковская д.3, офис 1107, 1118, ДЦ «Щербаковский»

Телефон: +7 495 668-12-70 (многоканальный)

Факс: +7 495 668-12-70 (доб.304)

E-mail: info@moschip.ru

Skype отдела продаж:

moschip.ru

moschip.ru_4

moschip.ru_6

moschip.ru_9