

High Speed Continuous Rotation Servo (#900-00025)

Parallax's High Speed Continuous Rotation Servo offers easily controlled bi-directional rotation via simple pulse width modulation. With about 3 times the RPM of the original Parallax Continuous Rotation Servo, it makes an excellent drive motor for small, zippy robots.

Features

- Bi-directional continuous rotation
- Up to 150 RPM @ 6 VDC, or 180 RPM @ 7.4 VDC
- Linear response to PWM for easy ramping
- Accepts four mounting screws
- 3-pin ground-power-signal cable and female header with 0.1" spacing for quick connection
- Easy to interface with any Parallax microcontroller or other PWM-capable device
- Very easy to control; examples available for many programming languages



Key Specifications

- Power requirements: 6.0 to 8.0 VDC; Maximum current draw 130 +/- 50 mA @ 7.4 VDC when operating in no load conditions, 15 mA @ 7.4 VDC when in static state
- Communication: pulse-width modulation
- Speed: 0.30 +/- 0.06 sec/360°
- Torque: 22 +/- 11 oz-in (1.6 +/- 0.8 kg-cm) @ 7.4 V
- Weight: 1.5 oz (42 g)
- Dimensions: approx. 2.2 x 0.8 x 1.6 in (56 x 19 x 41 mm) excluding servo horn
- Operating temperature range: 14 to 113 °F (-10 to +45 °C)

Quick-Start Circuit

Connect the servo to your microcontroller as shown in the diagram.

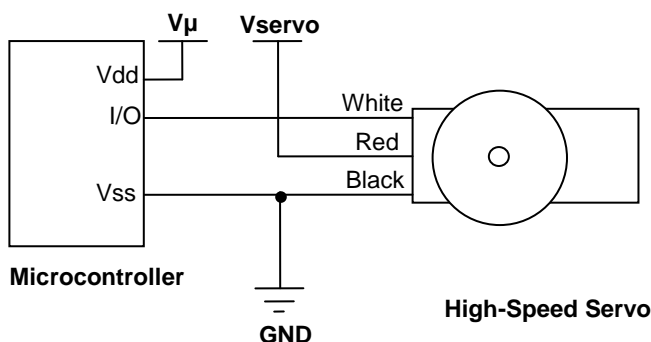

V μ = microcontroller voltage supply

Vservo = 6 to 7.5 VDC, regulated or battery

I/O = PWM TTL or CMOS output signal, 3.3 to 5 V; < Vservo + 0.2 V

Pin Descriptions

Pin	Name	Description	Minimum	Typical	Maximum	Units
1 (White)	Signal	Input; TTL or CMOS	3.3	5.0	Vservo + 0.2	V
2 (Red)	Vservo	Power Supply	6.0	7.4	8.4	V
3 (Black)	Vss	Ground		0		V

Precautions

- Do not use this servo with an unregulated wall-mount supply. Such power supplies may deliver variable voltage far above the stated voltage.
- Do not power this servo through your microcontroller.
- Servo current draw can spike while under peak load; **stall current can approach 1 A**. Be sure your application's regulator is prepared to supply adequate current for all servos and other circuits used in combination.

Downloads

The latest version of this document is available on the High Speed Continuous Rotation Servo product page. Go to www.parallax.com and search "900-00025".

Servo Control

The Parallax High Speed Continuous Rotation Servo is controlled through pulse width modulation. Rotational speed and direction are determined by the duration of a high pulse, refreshed every 20 ms.

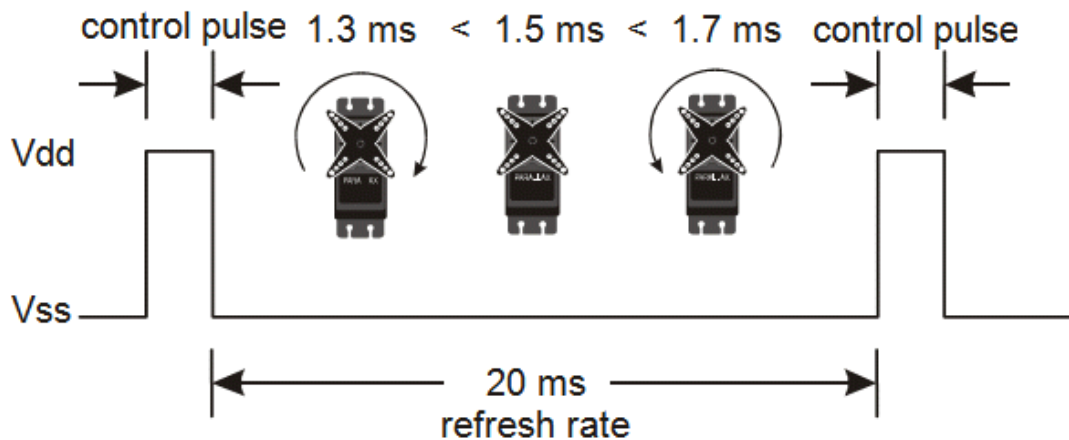

- A 1.52 ms control pulse makes the servo stand still (unless calibrated to 1.50 ms, see Calibration – Changing the Servo's "Center" Value, page 4).
- As pulse width decreases from 1.52 ms to 1.3 ms, the servo gradually rotates faster, clockwise.
- As pulse width increases from 1.52 ms to 1.7 ms, the servo gradually rotates faster, counterclockwise.

Rotational Velocity vs. Pulse Width

The graph below shows the relationship between rotational velocity and control pulse width, assuming two servos are mounted to a robot chassis.

It is important to note that while the velocity response curve is consistent for each servo, the positive velocity response near 1.4 ms has a much sharper curve than the negative velocity response curve near 1.6 ms.

The net effect is that when two servos are mounted on a robot, pulse widths equidistant from the center value of 1.52 ms will not result in the same rotational speed, and the robot will veer slightly to one side.

For robotics navigation applications that do not incorporate frequent course adjustment from object sensors, this can be compensated for in software, or with the use of encoders.

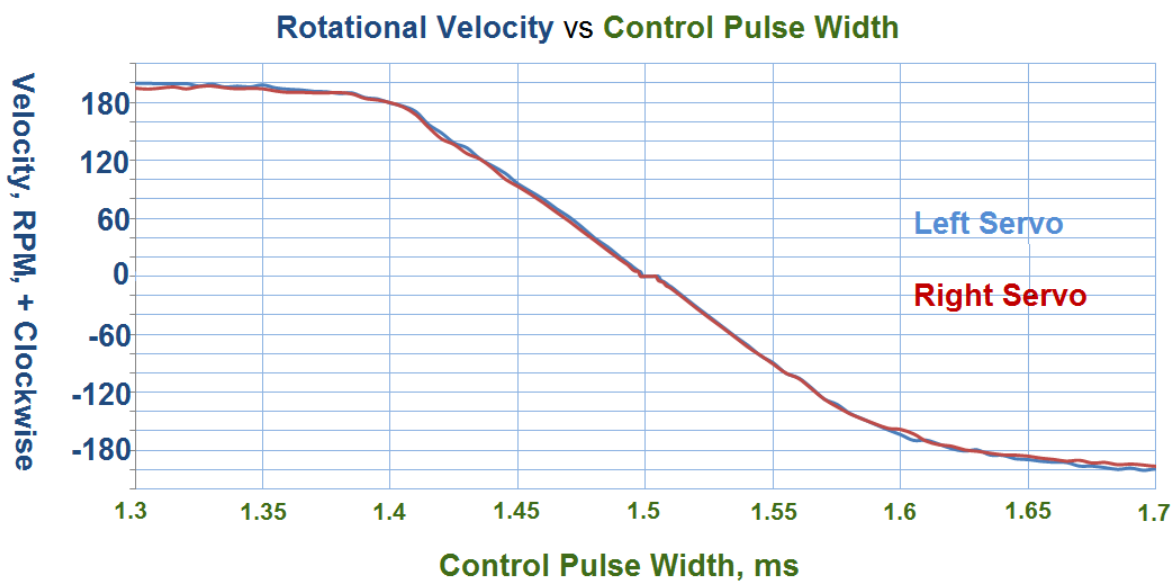

Voltage and Speed

Maximum speed will vary with input voltage; 0.30 +/- 0.06 sec/360° @ 7.4 V is the typical maximum.

Upgrading from Original to High Speed Continuous Rotation Servos

If you are upgrading a project from the original Parallax Continuous Rotation Servos (#900-00008) to the High Speed Continuous Rotation servos, keep these things in mind:

Power supply upgrade

The original Continuous Rotation servos require a 4–6 VDC input, while the High Speed servos work optimally with 7.5 VDC. If your application has a 4-cell AA battery pack, consider upgrading to the 5-AA Battery Holder (#753-00007). Or, add a Boe-Boost module (#30078) to hold an additional battery. This will provide 7.5 V using 1.5 V AA batteries.

Center the servos if needed

If your application uses servo code that assumes a 1.50 ms stay-still pulse width, see Calibration – Changing the Servo's "Center" Value, page 4). It is possible to use the same code as you did to center the original Parallax Continuous Rotation Servos for your initial application.

Tuning for straight lines

See Rotational Velocity vs. Pulse Width, page 3. For robotics applications that use these as drive servos, you may need to manually adjust the right and left speed values for straight-line travel.

Adjusting sensor-based navigation code

Since the High Speed servos are about 3 times faster than the Parallax Continuous Rotation servos, every programmed sensor-response movement will be greatly exaggerated. That means that a robot may travel three times farther forward before it next checks for an obstacle, or rotate three times farther to choose a new heading. You may need to reduce the number of times each servo's control loop executes in order to compensate for your robot's newfound need for speed.

Reduced torque

Our High Speed Continuous Rotation Servos have less torque (1.6 +/- 0.8 kgf.cm) compared to the original Parallax Continuous Rotation Servo (2.8 +/- 0.3 kgf.cm). If your previous application required a lot of torque, the High Speed servos may stall.

Calibration – Changing the Servo's "Center" Value

The servo has a potentiometer access port, right above the place where the cable attaches to the case. The port allows the user to adjust the pulse width at which the servo to hold completely still; the default value is a 1.52 ms pulse width. This is the value in the "center" of the range of control pulses the servo will respond to, between approximately 1.3 ms and 1.7 ms.

You may adjust the center "stay still" value to 1.50 ms. This may be useful if adapting these servos to existing application code that assumes a 1.50 ms center pulse.

1. Connect your servo to your microcontroller using the Quick Start circuit on page 1.
2. Program your host device to deliver a 1.50 ms high pulse, continually refreshed every 20 ms, to the I/O pin connected with the servo's signal pin. This should cause the servo to rotate slowly.
3. Insert a Phillips-point screwdriver into the servo's potentiometer access port. DO NOT PUSH HARD. Gently twist the screwdriver until the servo stays still.

Revision History

- 1.1 – Fixed typos; removed incorrect references to example applications on product page; added revision history.

Данный компонент на территории Российской Федерации

Вы можете приобрести в компании MosChip.

Для оперативного оформления запроса Вам необходимо перейти по данной ссылке:

<http://moschip.ru/get-element>

Вы можете разместить у нас заказ для любого Вашего проекта, будь то серийное производство или разработка единичного прибора.

В нашем ассортименте представлены ведущие мировые производители активных и пассивных электронных компонентов.

Нашей специализацией является поставка электронной компонентной базы двойного назначения, продукции таких производителей как XILINX, Intel (ex.ALTERA), Vicor, Microchip, Texas Instruments, Analog Devices, Mini-Circuits, Amphenol, Glenair.

Сотрудничество с глобальными дистрибьюторами электронных компонентов, предоставляет возможность заказывать и получать с международных складов практически любой перечень компонентов в оптимальные для Вас сроки.

На всех этапах разработки и производства наши партнеры могут получить квалифицированную поддержку опытных инженеров.

Система менеджмента качества компании отвечает требованиям в соответствии с ГОСТ Р ИСО 9001, ГОСТ РВ 0015-002 и ЭС РД 009

Офис по работе с юридическими лицами:

105318, г.Москва, ул.Щербаковская д.3, офис 1107, 1118, ДЦ «Щербаковский»

Телефон: +7 495 668-12-70 (многоканальный)

Факс: +7 495 668-12-70 (доб.304)

E-mail: info@moschip.ru

Skype отдела продаж:

moschip.ru

moschip.ru_4

moschip.ru_6

moschip.ru_9