

Magnecraft Time Delay and Sensor Relays

Catalog
2015

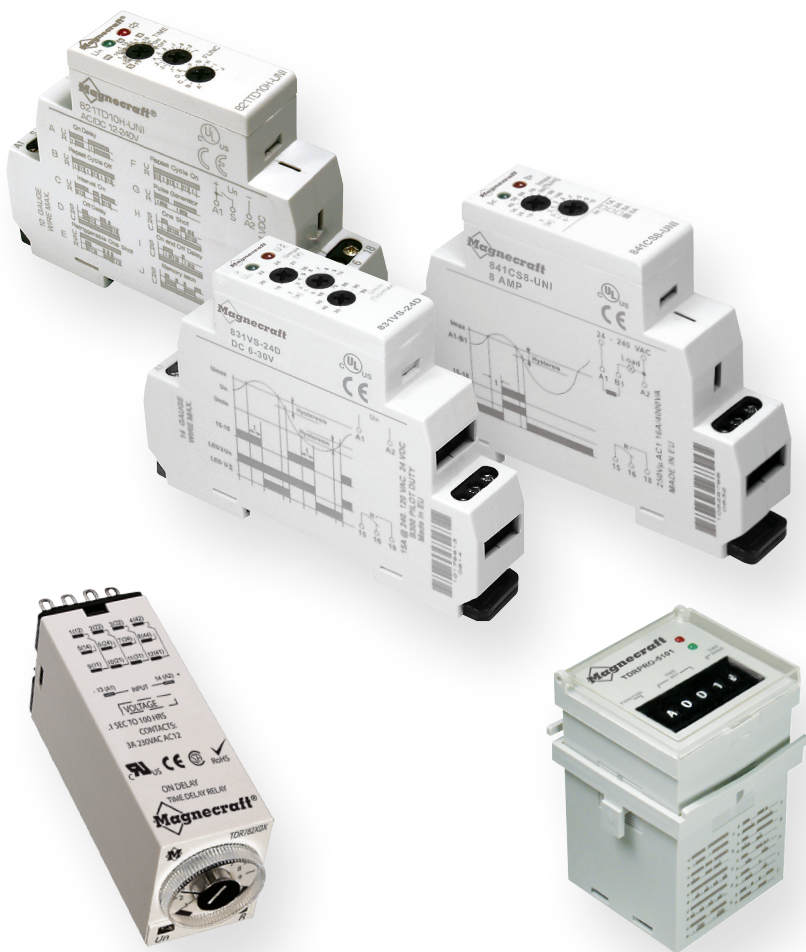

Magnecraft™ Time Delay and Sensor Relays

■ Series Overview	3
■ 820 Series Relays	4
■ 831 Series Voltage Sensing Relays	7
■ 841 Series Current Sensing Relays	10
■ 800 Series Accessories	13
■ TDR782 Series Relays	14
■ TDR782 Series Accessories	17
■ TDRPRO Series Relays	22
■ TDRPRO Series Accessories	25
■ Application Data	30
■ Website Guide	34
■ Index	35

Magnecraft Time Delay and Sensor Relays

Magnecraft time delay and sensor relays are designed to provide cost effective solutions for your industrial timing and sensing needs. Available in a wide array of forms, fits and functions, Magnecraft timers offer the ultimate in flexibility and performance. Accurate adjustments, legible wiring diagrams and an interactive timer demo make selection quick and easy.

Key Features

- Multiple timing functions
- Wide voltage range from 12 to 240 V
- Single timing range or from 100 ms to 10 days
- DIN or Panel mounting styles
- Conforms to international standards including UL, CSA, RoHS and CE IEC



Series	Style	Contact Configuration	Rated Current Load (A)	Timing Range	Number of Functions	Function Type	Input Voltage Range	Page
820 Relays	Time delay relay DIN mount	SPST	15	100 ms to 10 days	10	All	12 to 240 Vac/Vdc	4
		DPDT						
831 Voltage Sensing Relays	Voltage Sensing DIN mount relay	SPDT	15	100 ms to 10 sec	1	On Delay	120 Vac; 240 Vac; 24 Vdc	7
841 Current Sensing Relays	Current sensing DIN mount relay	SPDT	15	100 ms to 10 sec	1	On Delay	24 to 240 Vac	10
TDR782 Relays	Time delay relay Plug-in w/ Dial	DPDT	5	100 ms to 100 hrs	1	On Delay	12, 24 Vdc; 24, 110, 230 Vac	14
		4PDT	3					
TDRPRO Relays	Time delay relay Plug-in w/ 5 Digit Thumbwheel	SPDT	12	100 ms to 9990 hrs	10	All	12 to 240 Vac/Vdc	22
		DPDT			3	On Delay / Repeat Cycle / On Interval		

Description

Magnecraft Time Delay and Sensor Relays

820 Series

SPDT, 15 A; DPDT, 15 A

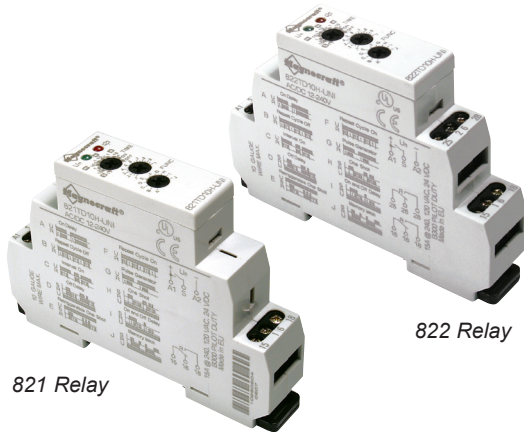

Description

The 820 Series Time Delay Relays are 35 mm DIN rail mountable products offering 10 different timing functions, ultra-wide timing range (10 ms to 10 days) and a universal voltage input (12-240 Vac/Vdc), all in a slim 17.5 mm (0.69 in) modular package.

Feature	Benefit
Up to 10 functions	5 timing functions controlled via supply voltage 4 timing functions controlled via trigger input 1 function of memory latching Meets most timing requirements
Contact configuration	SPDT or DPDT
Universal power supply	12 to 240 Vac/Vdc
2 LED status indicators	Shows status at a glance
Only 17.5 mm (0.69 in) wide	Ideal for tight spaces
DIN rail mountable	Easy installation / Screwdriver required
RoHS compliant	Environmentally friendly

Input Voltage	Functions Available (1)	Timing Range	Contact Configuration	Rated Current (A)	Standard Part Number
12-240 Vac/Vdc	A,B,C,D,E,F,G,H,I,J	10 ms - 10 days	SPDT	15	821TD10H-UNI
12-240 Vac/Vdc	A,B,C,D,E,F,G,H,I,J	10 ms - 10 days	DPDT	2 x 15 A (2 pairs of contacts)	822TD10H-UNI

(1) For function descriptions, see pages 30 and 31.

Part Number Explanation

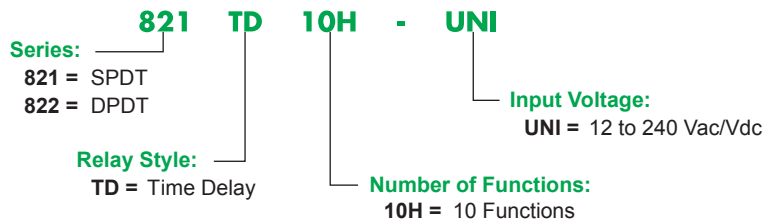

Magnecraft Time Delay and Sensor Relays

820 Series

SPDT, 15 A; DPDT, 15 A

Specifications

Part Number	821TD10H-UNI	822TD10H-UNI
Input Characteristics		
Input Voltage Range	12-240 Vac / Vdc	12-240 Vac / Vdc
Operating Voltage (% of Nominal)	85% of 12 V – 110% of 240 V	85% of 12 V – 110% of 240 V
Maximum Power Consumption	3 VA 1.7 W	3 VA 1.7 W
Output Characteristics		
Contact Configuration	SPDT	DPDT
Output Current Rating	15 A	15 A
Contact Material	Silver Alloy	Silver Alloy
Switching Capability	15 A @ 240 Vac, 50/60 Hz, 24 Vdc 1/2 HP @ 120 Vac 1 HP @ 240 Vac Pilot Duty B300	15 A @ 240 Vac, 50/60 Hz, 24 Vdc 1/2 HP @ 120 Vac 1 HP @ 240 Vac Pilot Duty B300
Minimum Switching Requirement	100 mA	100 mA
Timing Characteristics		
Functions Available (1)	All	All
Time Scales	8	8
Time Ranges	100 ms to 1 sec 1 sec to 10 sec 0.1 min to 1 min 1 min to 10 min 1 hr to 10 hrs 0.1 hr to 1 hrs 1 day to 10 day 0.1 day to 1 day	100 ms to 1 sec 1 sec to 10 sec 0.1 min to 1 min 1 min to 10 min 1 hr to 10 hrs 0.1 hr to 1 hrs 1 day to 10 day 0.1 day to 1 day
Tolerance	5% of Mechanical setting	5% of Mechanical setting
Repeatability @ constant voltage and temperature	0.2%	0.2%
Reset Time	150 ms maximum	150 ms maximum
Trigger Pulse Length	50 ms minimum	50 ms minimum
General Characteristics		
Electrical Life (operations at rated current) (2)	70,000 operations	70,000 operations
Mechanical Life (Unpowered) (2)	10,000,000 operations	10,000,000 operations
Dielectric Strength (Input to Contacts)	2500 Vac	2500 Vac
Dielectric Strength (Between Open Contacts)	1600 Vac	1600 Vac
Storage Temperature Range	-30°C (-22°F) to +70°C (+158°F)	-30°C (-22°F) to +70°C (+158°F)
Operating Temperature Range	-20°C (-4°F) to +55°C (+131°F)	-20°C (-4°F) to +55°C (+131°F)
Terminal Wire Capacity (Input and Output)	14 AWG (2.1 mm ²) maximum	14 AWG (2.1 mm ²) maximum
Terminal Screw Torque	7.1 lb-in (0.8 N•m) maximum	7.1 lb-in (0.8 N•m) maximum
Weight	55 g (1.9 oz)	70 g (2.5 oz)
Input Indication	Green LED	Green LED
Output Indication (Blinks = Timing or On = Energized)	Red LED	Red LED
Enclosure Rating (according to IEC 60529 IP rating)	IP20	IP20
Approvals	cULus (file no. E234203), CE 61810-1, RoHS	cULus (file no. E234203), CE 61810-1, RoHS

(1) For function descriptions, see pages 30 and 31.

(2) Actual product life will vary based on electrical load, duty cycle, application, and environmental conditions.

Dimensions, Wiring Diagram

Magnecraft Time Delay and Sensor Relays

820 Series
SPDT, 15 A; DPDT, 15 A

Dimensions — inches (millimeters)

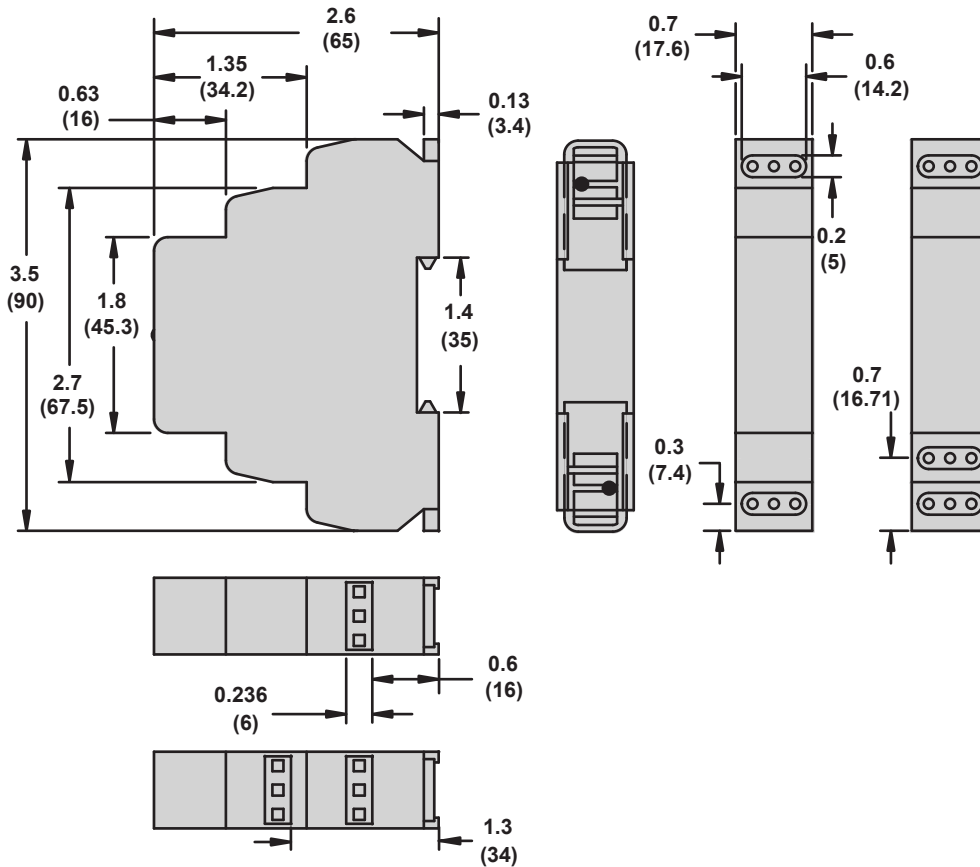

Wiring Diagram

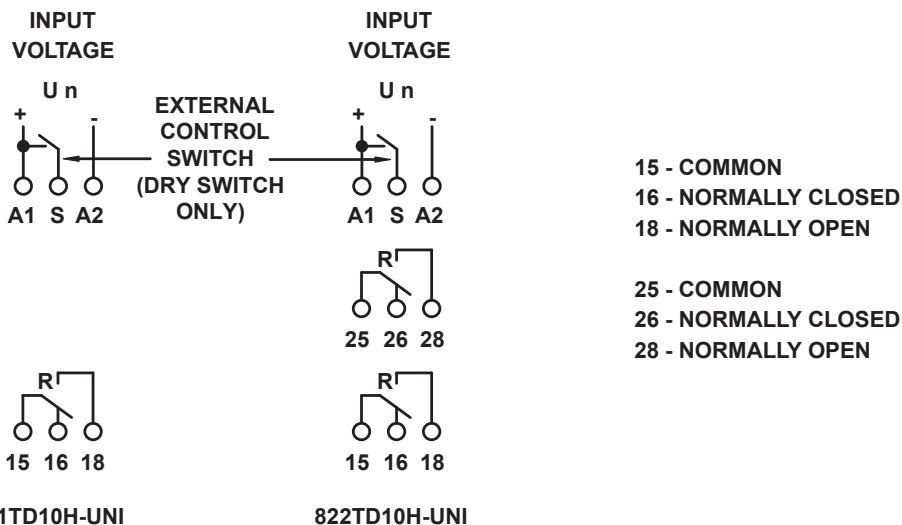

Description

Magnecraft Time Delay and Sensor Relays

831 Series
SPDT, 15 A



831 Relay

Description

The 831 voltage sensor is a single-phase AC voltage sensing device that is capable of monitoring and reacting to over and under voltage conditions. This product is designed to be wired across terminals A1 and A2 with the voltage that is being monitored. The two LED lamps indicate both when the input voltage is present (Green LED) and also when the output is energized (Red LED). The Umax dial is used to set the upper trip-point for the voltage sensor. The Umin dial is a percentage of the Umax dial and is used to set the lower trip-point for the voltage sensor. The timing dial is used to delay the transfer of the contacts, from 0 to 10 seconds, when a set point has been violated.

Feature	Benefit
3-state indication LEDs	Indicates normal state and 2 types of faulted states
Timing dial	Adjustable delay 0-10 sec
DIN mountable	Mounts directly on 35 mm DIN rail
Current rating is 15A @ 240 Vac, 24 Vdc	High switching capacity
Only 17.5 mm (0.69 in) wide	Ideal for tight spaces

Nominal Input Voltage	Sensing Voltage Range	Timing Range	Contact Configuration	Rated Current (A)	Standard Part Number
120 Vac	Upper: 85 to 150 Vac Lower: 30 to 99% of upper	0 sec - 10 sec	SPDT	15	831VS-120A
240 Vac	Upper: 160 to 276 Vac Lower: 30 to 99% of upper	0 sec - 10 sec	SPDT	15	831VS-240A
24 Vdc	Upper: 18 to 30 V Lower: 30 to 99% of upper	0 sec - 10 sec	SPDT	15	831VS-24D

Part Number Explanation

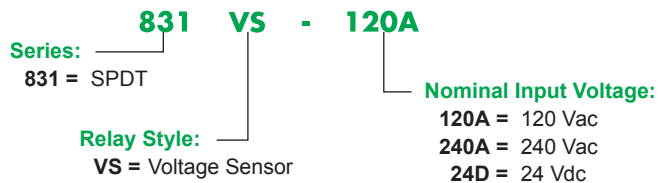

Magnecraft Time Delay and Sensor Relays

831 Series
SPDT, 15 A

Specifications

Part Number	831VS-120A	831VS-240A	831VS-24D
Input Characteristics			
Nominal Input Voltage	120 Vac	240 Vac	24 Vdc
Absolute Input Voltage Maximum	200 Vac	280 Vac	35 Vdc
Upper Supply Voltage Range	85 to 150 Vac	160 to 276 Vac	18 to 30 Vdc
Lower Supply Voltage Range	30 to 99% of upper preset	30 to 99% of upper preset	30 to 99% of upper preset
Maximum Power Consumption	1.2 VA	1.2 VA	1.2 W
Time Delay	adjustable 0 to 10 sec	adjustable 0 to 10 sec	adjustable 0 to 10 sec
Accuracy			
Mechanical Setting	5%	5%	5%
Repeat Accuracy	<1%	<1%	<1%
Temperature Variation	<1% / °C	<1% / °C	<1% / °C
Hysteresis (from fault to normal)	2 to 6% of adjusted value	2 to 6% of adjusted value	2 to 6% of adjusted value
Output Characteristics			
Contact Configuration	1C / SPDT	1C / SPDT	1C / SPDT
Output Current Rating	15 A @ 120, 240 Vac, 24 Vdc	15 A @ 120, 240 Vac, 24 Vdc	15 A @ 120, 240 Vac, 24 Vdc
Breaking Capacity	4000 VA/AC1, 384 W/DC	4000 VA/AC1, 384 W/DC	4000 VA/AC1, 384 W/DC
Inrush Current	30 A / <3 sec	30 A / <3 sec	30 A / <3 sec
Maximum Switching Voltage	250 Vac / 24 Vdc	250 Vac / 24 Vdc	250 Vac / 24 Vdc
Minimum Breaking Capacity DC	500 mW	500 mW	500 mW
Mechanical Life	3.00E+07	3.00E+07	3.00E+07
Electrical Life	7.00E+04	7.00E+04	7.00E+04
Contact Material	Silver Alloy	Silver Alloy	Silver Alloy
Switching Capability	15 A @ 240 Vac, 50/60 Hz, 24 Vdc 1/2 HP @ 120 Vac 1 HP @ 240 Vac Pilot Duty B300	15 A @ 240 Vac, 50/60 Hz, 24 Vdc 1/2 HP @ 120 Vac 1 HP @ 240 Vac Pilot Duty B300	15 A @ 240 Vac, 50/60 Hz, 24 Vdc 1/2 HP @ 120 Vac 1 HP @ 240 Vac Pilot Duty B300
Minimum Switching Requirement	100 mA at 5 Vac or Vdc	100 mA at 5 Vac or Vdc	100 mA at 5 Vac or Vdc
Timing/Sensing Characteristics			
Time Scales	1	1	1
Time Ranges	0 sec to 10 sec	0 sec to 10 sec	0 sec to 10 sec
Tolerance	5% of Mechanical setting	5% of Mechanical setting	5% of Mechanical setting
Repeatability @ constant voltage and temperature	1%	1%	1%
Upper Sensing Voltage Range	85 to 150 Vac	160 to 276 Vac	18 to 30 Vdc
Lower Sensing Voltage Range	30 to 99% of upper preset	30 to 99% of upper preset	30 to 99% of upper preset
General Characteristics			
Dielectric Strength (Input to Contacts)	2.5 kV (I/O)	2.5 kV (I/O)	2.5 kV (I/O)
Dielectric Strength (Between Open Contacts)	1600 Vac	1600 Vac	1600 Vac
Mounting Position	Any, 35 mm DIN rail EN 50022	Any, 35 mm DIN rail EN 50022	Any, 35 mm DIN rail EN 50022
Overvoltage Category	III	III	III
Pollution Degree	2	2	2
Storage Temperature Range	-30°C (-22°F) to +70°C (+158°F)	-30°C (-22°F) to +70°C (+158°F)	-30°C (-22°F) to +55°C (+131°F)
Operating Temperature Range	-20°C (-4°F) to +55°C (+131°F)	-20°C (-4°F) to +55°C (+131°F)	-20°C (-4°F) to +55°C (+131°F)
Terminal Wire Capacity (Input and Output)	14 AWG (2.5 mm ²) maximum	14 AWG (2.5 mm ²) maximum	14 AWG (2.5 mm ²) maximum
Terminal Screw Torque	7.1 Lb-in (0.8 N•m) maximum	7.1 Lb-in (0.8 N•m) maximum	7.1 Lb-in (0.8 N•m) maximum
Weight	62 g (2.19 oz)	62 g (2.19 oz)	88 g (3.10 oz)
Input Indication	Green LED	Green LED	Green LED
Output Indication (Blinks = Timing or On = Energized)	Red LED	Red LED	Red LED
Enclosure Rating (according to IEC 60529 IP rating)	IP40	IP40	IP40
Approvals	UL (E234203), CE (IEC 60947-1, 61000-4), RoHS	UL (E234203), CE (IEC 60947-1, 61000-4), RoHS	UL (E234203), CE (IEC 60947-1, 61000-4), RoHS

(1) Actual product life will vary based on electrical load, duty cycle, application, and environmental conditions.

Dimensions — inches (millimeters)

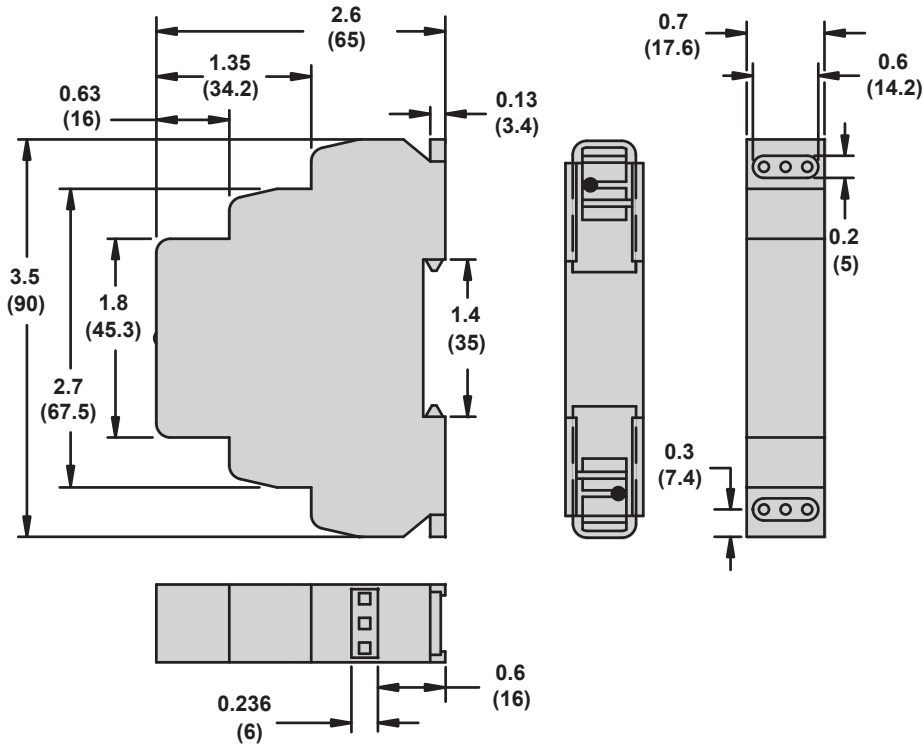

Wiring Diagram

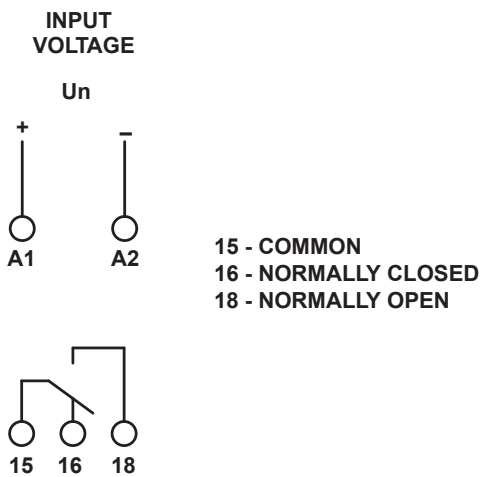

Description

Magnecraft Time Delay and Sensor Relays

841 Series
SPDT, 15 A



841 Relay

Description

Current sensing relay which allows the user to monitor the current of one circuit (1 to 8 A) and switch another circuit in case of an over current condition; all in a modular, Fingersafe (according to IEC 60529 IP rating) package.

Feature	Benefit
Current sensing adjustment knob	Sense anywhere from 10% to 100% of the rated sensing current
Input/output terminals	Accepts up to a 14 AWG Wire
Solid state circuitry	Used for precise sensing and timing control
Input/output indication	Shows status at a glance
DIN rail mountable	Mounts directly on a DIN Rail
Only 17.5 mm (0.69 in) wide	Ideal for tight spaces
Wide input range	Enabled to work with common AC voltages.

Input Voltage	Sensing Current Range (AC)	Timing Range	Contact Configuration	Output (A)	Standard Part Number
24 to 240 Vac	100 mA to 1 A	100 ms to 10 sec	SPDT	15 A	841CS1-UNI
24 to 240 Vac	200 mA to 2 A	100 ms to 10 sec	SPDT	15 A	841CS2-UNI
24 to 240 Vac	500 mA to 5 A	100 ms to 10 sec	SPDT	15 A	841CS5-UNI
24 to 240 Vac	800 mA to 8 A	100 ms to 10 sec	SPDT	15 A	841CS8-UNI

Part Number Explanation

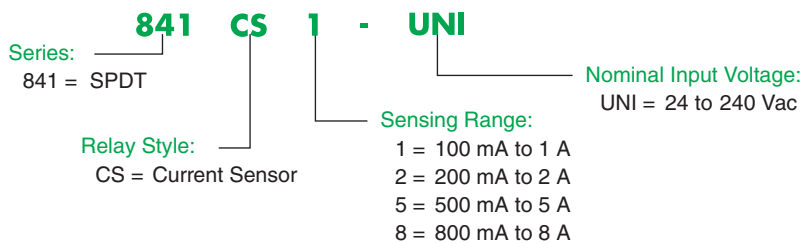

Magnecraft Time Delay and Sensor Relays

841 Series

SPDT, 15 A

Specifications

Part Number	841CS1-UNI	841CS2-UNI	841CS5-UNI	841CS8-UNI
Input Characteristics				
Input Voltage Range	24 to 240 Vac	24 to 240 Vac	24 to 240 Vac	24 to 240 Vac
Maximum Power Consumption	1.2 VA	1.2 VA	1.2 VA	1.2 VA
Output Characteristics				
Contact Configuration	SPDT	SPDT	SPDT	SPDT
Output Current Rating	15 A	15 A	15 A	15 A
Contact Material	Silver Alloy	Silver Alloy	Silver Alloy	Silver Alloy
Switching Capability	15A @ 240 Vac, 50/60 Hz, 24 Vdc 1/2 HP @ 120 Vac 1 HP @ 240 Vac Pilot Duty B300	15A @ 240 Vac, 50/60 Hz, 24 Vdc 1/2 HP @ 120 Vac 1 HP @ 240 Vac Pilot Duty B300	15A @ 240 Vac, 50/60 Hz, 24 Vdc 1/2 HP @ 120 Vac 1 HP @ 240 Vac Pilot Duty B300	15A @ 240 Vac, 50/60 Hz, 24 Vdc 1/2 HP @ 120 Vac 1 HP @ 240 Vac Pilot Duty B300
Minimum Switching Requirement	100 mA at 5 Vac or Vdc	100 mA at 5 Vac or Vdc	100 mA at 5 Vac or Vdc	100 mA at 5 Vac or Vdc
Timing/Sensing Characteristics				
Time Scales	1	1	1	1
Time Ranges	0 sec to 10 sec	0 sec to 10 sec	0 sec to 10 sec	0 sec to 10 sec
Tolerance	5% of Mechanical setting	5% of Mechanical setting	5% of Mechanical setting	5% of Mechanical setting
Repeatability @ constant voltage and temperature	1%	1%	1%	1%
Sensing Range	100 mA to 1 A	200 mA to 2 A	500 mA to 5 A	800 mA to 8 A
General Characteristics				
Electrical Life (operations at rated current) (1)	70,000 operations	70,000 operations	70,000 operations	70,000 operations
Mechanical Life (Unpowered) (1)	10,000,000 operations	10,000,000 operations	10,000,000 operations	10,000,000 operations
Dielectric Strength (Input to Contacts)	2500 Vac	2500 Vac	2500 Vac	2500 Vac
Dielectric Strength (Between Open Contacts)	1600 Vac	1600 Vac	1600 Vac	1600 Vac
Storage Temperature Range	-30°C (-22°F) to +70°C (+158°F)	-30°C (-22°F) to +70°C (+158°F)	-30°C (-22°F) to +70°C (+158°F)	-30°C (-22°F) to +70°C (+158°F)
Operating Temperature Range	-20°C (-4°F) to +55°C (+131°F)	-20°C (-4°F) to +55°C (+131°F)	-20°C (-4°F) to +55°C (+131°F)	-20°C (-4°F) to +55°C (+131°F)
Terminal Wire Capacity (Input and Output)	14 AWG (2.1 mm ²) maximum	14 AWG (2.1 mm ²) maximum	14 AWG (2.1 mm ²) maximum	14 AWG (2.1 mm ²) maximum
Terminal Screw Torque	7.1 Lb-in (0.8 N•m) maximum	7.1 Lb-in (0.8 N•m) maximum	7.1 Lb-in (0.8 N•m) maximum	7.1 Lb-in (0.8 N•m) maximum
Weight	60 g (2.12 oz)	60 g (2.12 oz)	60 g (2.12 oz)	60 g (2.12 oz)
Input Indication	Green LED	Green LED	Green LED	Green LED
Output Indication (Blinks = Timing or On = Energized)	Red LED	Red LED	Red LED	Red LED
Enclosure Rating (according to IEC 60529 IP rating)	IP20	IP20	IP20	IP20
Approvals	cULus (File No. E234203), CE 61810-1, RoHS	cULus (File No. E234203), CE 61810-1, RoHS	cULus (File No. E234203), CE 61810-1, RoHS	cULus (File No. E234203), CE 61810-1, RoHS

(1) Actual product life will vary based on electrical load, duty cycle, application, and environmental conditions.

Dimensions — inches (millimeters)

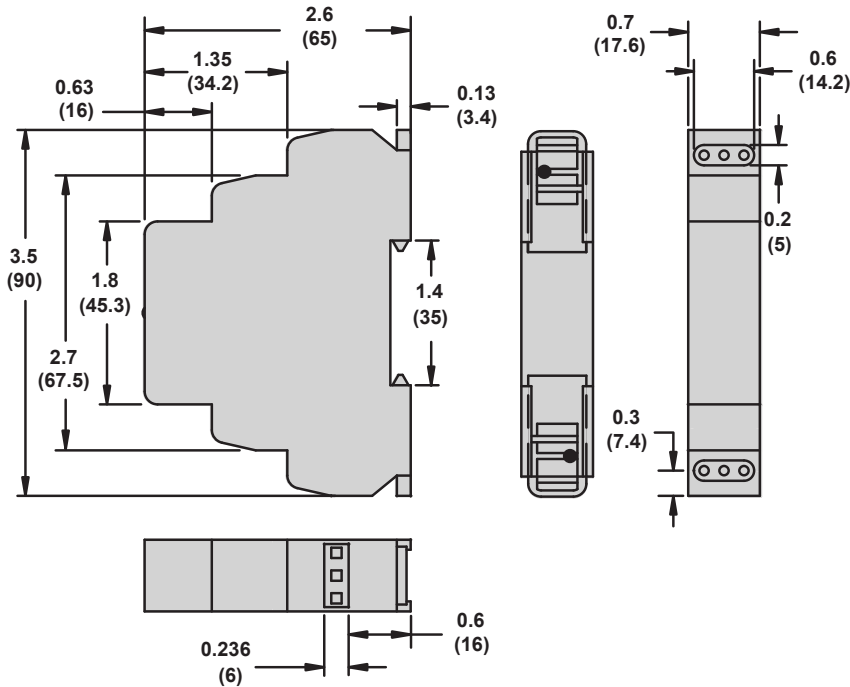

Wiring Diagram

Wiring for direct current sensing:

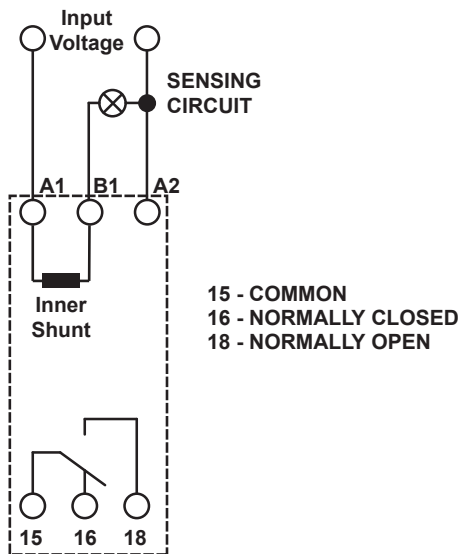

Wiring for current sensing through current transformer:

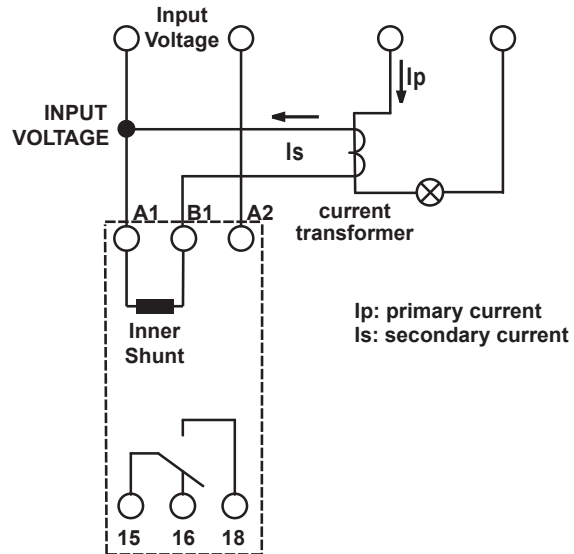

Magnecraft Time Delay and Sensor Relays

800 Series Accessories

Description

The 16-700DIN DIN Rail provides quick removable and installations of most sockets and the 16-788C1 panel adapter provides a panel mounting option.

16-700DIN DIN Rail

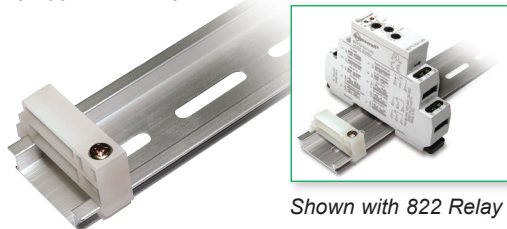

Shown with 822 Relay

16-788C1 Panel Adapter

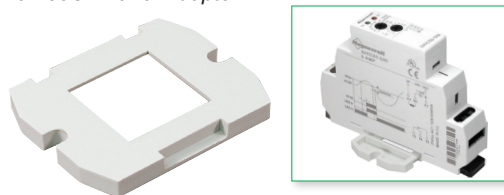

Shown with 841 Relay

Description	Function	For Use With Relays	Packaging Quantities	Standard Part Number
Metal DIN Rail	Quick installation and removable	821, 822, 831, 841	10 (1)	16-700DIN
Panel Adapter	Provides additional panel mount option.	821, 822, 831, 841	10	16-788C1

(1) Length is 39.3 inches.

Dimensions — inches (millimeters)

16-700DIN Metal DIN Rail

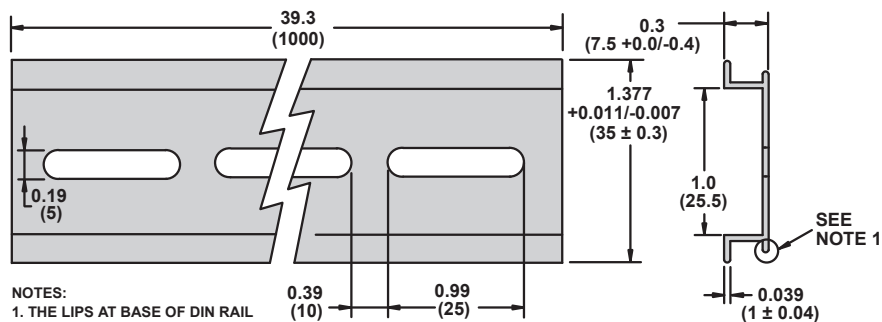

NOTES:
1. THE LIPS AT BASE OF DIN RAIL MAY OR MAY NOT BE PRESENT ON DIN RAIL EXTRUSIONS.

16-788C1 Panel Mount Adapter

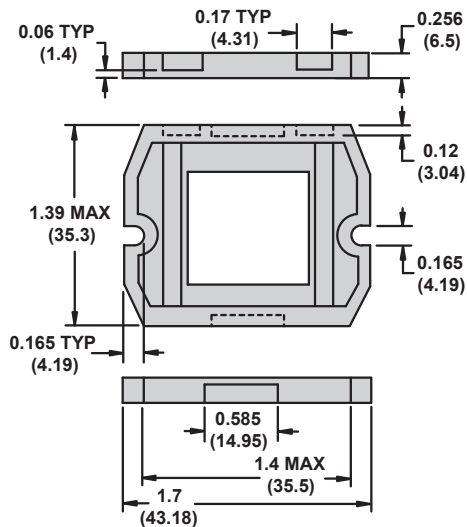

Description

Magnecraft Time Delay and Sensor Relays

TDR782 Series

DPDT, 5 A; 4PDT, 3 A



TDR782 Relay

Description

Miniature time delay relay that is single-function, single-voltage and socket-compatible. Ideal for tight spaces.

Feature	Benefit
Time setting	Select between 7 different time scales
Socket compatible	Mounts directly to DIN Rail or Panel
Input/Output indication	Shows status at a glance
Time adjustment dial	Fine tune the time setting
IEC and NEMA terminal numbering	For numbering compatibility

Input Voltage	Functions Available (1)	Timing Range	Contact Configuration	Rated Current (A)	Standard Part Number
110 Vac	A (On Delay)	100 ms to 100 hrs	DPDT	5 A	TDR782XBXA-110A
24 Vac	A (On Delay)	100 ms to 100 hrs	DPDT	5 A	TDR782XBXA-24A
24 Vdc	A (On Delay)	100 ms to 100 hrs	DPDT	5 A	TDR782XBXA-24D
110 Vac	A (On Delay)	100 ms to 100 hrs	4PDT	3 A	TDR782XDXA-110A
12 Vdc	A (On Delay)	100 ms to 100 hrs	4PDT	3 A	TDR782XDXA-12D
230 Vac	A (On Delay)	100 ms to 100 hrs	4PDT	3 A	TDR782XDXA-230A
24 Vac	A (On Delay)	100 ms to 100 hrs	4PDT	3 A	TDR782XDXA-24A
24 Vdc	A (On Delay)	100 ms to 100 hrs	4PDT	3 A	TDR782XDXA-24D

(1) For function descriptions, see pages 30 and 31.

Part Number Explanation

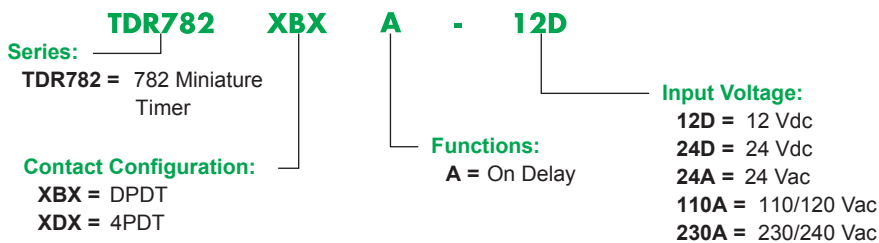

Magnecraft Time Delay and Sensor Relays

TDR782 Series
DPDT, 5 A; 4PDT, 3 A

Specifications

Part Number	TDR782XBX	TDR782DX
Input Characteristics		
Input Voltage Range	24, 110/120, 230/240 Vac 12, 24 Vdc	24, 110/120, 230/240 Vac 12, 24 Vdc
Operating Voltage (Vac)	85% to 115% of Nominal	85% to 115% of Nominal
Operating Voltage (Vdc)	90% to 110% of Nominal	90% to 110% of Nominal
Maximum Power Consumption	1.7 VA @ 24 Vac 2.6 VA @ 120 Vac 3 VA @ 230 Vac 1.5 W @ 12 Vdc 1.2 W @ 24 Vdc	1.7 VA @ 24 Vac 2.6 VA @ 120 Vac 3 VA @ 230 Vac 1.5 W @ 12 Vdc 1.2 W @ 24 Vdc
Output Characteristics		
Contact Configuration	DPDT	4PDT
Contacts Current Rating	5 A	3 A
Contact Material	Silver Alloy	Silver Alloy
Maximum inrush current	10A @ < 100 ms	10A @ < 100 ms
Minimum Switching Requirement	100 mA at 5 Vac or Vdc	100 mA at 5 Vac or Vdc
Timing Characteristics		
Functions Available (1)	A (On Delay)	A (On Delay)
Time Scales	7	7
Time Ranges	100 ms to 1 sec 1 sec to 10 sec 0.1 min to 1 min 1 min to 10 min 0.1 hr to 1 hr 1 hr to 10 hrs 10 hr to 100 hrs	100 ms to 1 sec 1 sec to 10 sec 0.1 min to 1 min 1 min to 10 min 0.1 hr to 1 hr 1 hr to 10 hrs 10 hr to 100 hrs
Tolerance	5% of Mechanical setting	5% of Mechanical setting
Repeatability @ constant voltage and temperature	0.5%	0.5%
Reset Time	50 ms maximum	50 ms maximum
Temperature Drift	0.05 % / °C	0.05 % / °C
General Characteristics		
Electrical Life (operations at rated current) (2)	100,000 operations	100,000 operations
Mechanical Life (Unpowered) (2)	10,000,000 operations	10,000,000 operations
Dielectric Strength (Input to Contacts)	2000 Vrms	2000 Vrms
Storage Temperature Range	-40°C (-40°F) to +70°C (+158°F)	-40°C (-40°F) to +70°C (+158°F)
Operating Temperature Range	-20°C (-4°F) to +60°C (+140°F)	-20°C (-4°F) to +60°C (+140°F)
Weight	43 g (1.52 oz)	43 g (1.52 oz)
Input Indication	Green LED	Green LED
Output Indication (On = Energized)	Amber LED	Amber LED
Enclosure Rating (according to IEC 60529 IP rating)	IP50	IP50
Approvals	cURus (File No. E191122), CSA (File No. 254373), CE 61810-1, RoHS	cURus (File No. E191122), CSA (File No. 254373), CE 61810-1, RoHS

(1) For function descriptions, see pages 30 and 31.

(2) Actual product life will vary based on electrical load, duty cycle, application, and environmental conditions.

Magnecraft Time Delay and Sensor Relays

TDR782 Series
DPDT, 5 A; 4PDT, 3 A

Dimensions — inches (millimeters)

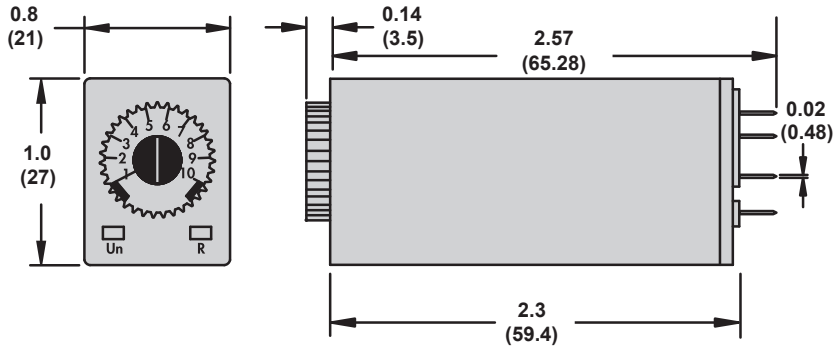

Wiring Diagram

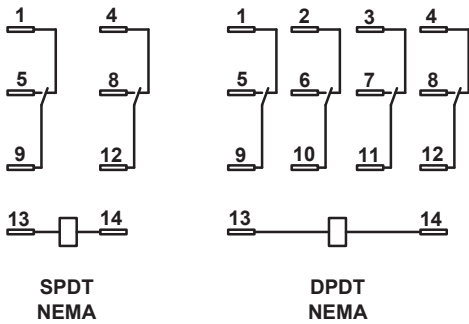

Magnecraft Time Delay and Sensor Relays

TDR782 Series Accessories

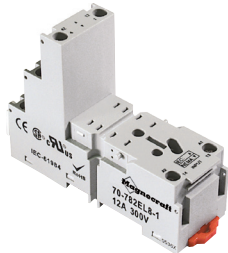

70-782EL8-1 Socket



70-782EL14-1 Socket

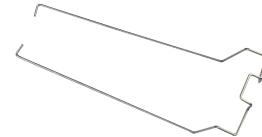

16-TDR782SC Spring Clip

Description

The TDR782 accessories create a complete system solution for all your application needs. The 70-782EL socket offers an alternate installation option for plug-in models. The 16-TDR782SC retention clip holds the relay securely in place while allowing quick and efficient installation and maintenance.

Relay Accessories

Description	Function	For Use With Relays	Packaging Quantities	Standard Part Number
Socket	Mounts directly to DIN Rail or Panel	TDR782XBX	10	70-782EL8-1
Socket	Mounts directly to DIN Rail or Panel	TDR782XBX TDR782XDX	10	70-782EL14-1
Socket	DIN/Panel Mount with Rising Elevator Box Terminals	TDR782XBX TDR782XDX	10	70-782E14-1
Socket	DIN/Panel Mount with Screw Terminals & Clamping Plates	TDR782XBX TDR782XDX	10	70-782D14-1
Socket	DIN/Panel Mount with Screw Terminals & Clamping Plates	TDR782XBX TDR782XDX	10	70-461-1
Socket	Solder Terminals for Chassis mount	TDR782XBX TDR782XDX	10	70-378-1
Socket	Printed Circuit Terminals	TDR782XBX TDR782XDX	10	70-379-1
Metal Hold-Down Clip	Helps secure relay in socket	TDR782●●	10	16-TDR782SC

Socket Accessories

Description	Function	For Use With Sockets	Packaging Quantities	Standard Part Number
Metal DIN Rail	Quick installation and removable of sockets	(See table above.)	10 (1)	16-700DIN
ID Tags	Allows for identification of circuits in multi-relay applications	70-782EL8-1 70-782EL14-1 70-782E14-1	10	16-782FT-1

(1) Length is 39.3 inches.

Magnecraft Time Delay and Sensor Relays

TDR782 Series Accessories

Specifications

Part Number	70-782EL8-1	70-782EL14-1	70-782E14-1
Contact Configuration	DPDT	4PDT	4PDT
Number of Terminals	8	14	14
Mounting Style	Panel/DIN Rail	Panel/DIN Rail	Panel/DIN Rail
Current Rating	12 A	10 A	10 A
Nominal Voltage Rating	300 V	300 V	300 V
Storage temperature Range	-40°C (-40°F) to +105°C (+221°F)	-40°C (-40°F) to +105°C (+221°F)	-40°C (-40°F) to +105°C (+221°F)
Protection Category (Fingersafe)	IP 20	IP 20	IP 20
Internal Metal Tracks	Copper Alloy, Zinc Plated	Copper Alloy, Zinc Plated	Copper Alloy, Zinc Plated
Screw Terminals	Steel, Zinc Plated	Steel, Zinc Plated	Steel, Zinc Plated
Screw Style	Combination Head	Combination Head	Combination Head
Screw Size	M3	M3	M3
Terminal Connection	Elevator	Elevator	Elevator
Terminal Layout	Logic	Logic	Non-Logic
Wire Size Capacity	Solid Cu 14 / 16 (2) AWG, 2.5 / 1.5 (2) mm ² Stranded Cu 14 / 16 (2) AWG, 2.5 / 1.5 (2) mm ²	Solid Cu 14 / 16 (2) AWG, 2.5 / 1.5 (2) mm ² Stranded Cu 14 / 16 (2) AWG, 2.5 / 1.5 (2) mm ²	Solid Cu 14 / 16 (2) AWG, 2.5 / 1.5 (2) mm ² Stranded Cu 14 / 16 (2) AWG, 2.5 / 1.5 (2) mm ²
DIN Rail Mounting, EN 60715	35 mm (1.38 in)	35 mm (1.38 in)	35 mm (1.38 in)
Maximum Screw Torque	7 lb-in (0.8 N•m)	7 lb-in (0.8 N•m)	7 lb-in (0.8 N•m)
Flammability Rating	94V-0 Class	94V-0 Class	94V-0 Class
Body Color	Light Gray	Light Gray	Light Gray
DIN Locking Method	Red Plastic Locking Clip	Red Plastic Locking Clip	Metal Compression Spring
Product Certifications	cURus (File No. E70550), CSA (File No. 40787), CE 60947-1, RoHS	cURus (File No. E70550), CSA (File No. 40787), CE 60947-1, RoHS	cURus (File No. E70550), CSA (File No. 40787), CE 60947-1, RoHS

Part Number	70-379-1	70-378-1	70-461-1, 70-782D14-1
Contact Configuration	4PDT	4PDT	4PDT
Number of Terminals	14	14	14
Mounting Style	PCB	Chassis	Panel/DIN Rail
Current Rating	5A	5A	10A
Nominal Voltage Rating	300 V	300 V	300 V
Storage temperature Range	-40°C (-40°F) to +105°C (+221°F)	-40°C (-40°F) to +105°C (+221°F)	-40°C (-40°F) to +105°C (+221°F)
Protection Category (Fingersafe)	–	–	IP 20 (for 70-782D14-1)
Internal Metal Tracks	Copper Alloy, Zinc Plated	Copper Alloy, Zinc Plated	Copper Alloy, Zinc Plated
Screw Terminals	Copper Alloy, Zinc Plated	Copper Alloy, Zinc Plated	Steel, Zinc Plated
Screw Style	–	–	Combination Head
Screw Size	–	–	M3 mm
Terminal Connection	PCB	Solder	Screw Clamping
Terminal Layout	Non Logic	Non Logic	Non-Logic
Wire Size Capacity	–	Solid Cu 14 / 16 (2) AWG, 2.5 / 1.5 (2) mm ² Stranded Cu 14 / 16 (2) AWG, 2.5 / 1.5 (2) mm ²	Solid Cu 14 / 16 (2) AWG, 2.5 / 1.5 (2) mm ² Stranded Cu 14 / 16 (2) AWG, 2.5 / 1.5 (2) mm ²
DIN Rail Mounting, EN 60715	–	–	35 mm (1.38 in)
Maximum Screw Torque	–	–	7 lb-in (0.8 N•m)
Flammability Rating	94V-0 Class	94V-0 Class	94V-0 Class
Body Color	Light Gray	Light Gray	Light Gray
DIN Locking Method	–	–	Red Plastic Locking Clip
Product Certifications	cURus (File No. E70550), CSA (File No. 97899), CE 60947-1, RoHS	cURus (File No. E70550), CSA (File No. 97899), CE 60947-1, RoHS	70-461-1: cURus (File No. E70550), CSA (File No. 97899), CE 60947-1, RoHS 70-782D14-1: cURus (File No. E70550), CSA (File No. 40787), CE 60947-1, RoHS

Magnecraft Time Delay and Sensor Relays

TDR782 Series Accessories

Dimensions — inches (millimeters)

70-782EL8-1

Mounts directly to DIN Rail or Panel

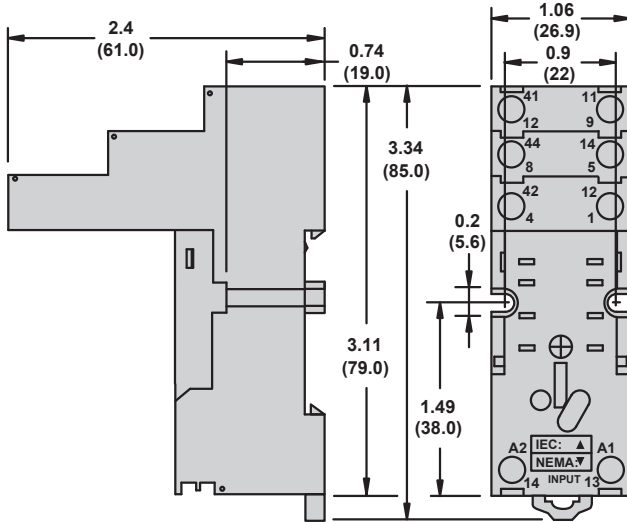

70-782EL14-1

Mounts directly to DIN Rail or Panel

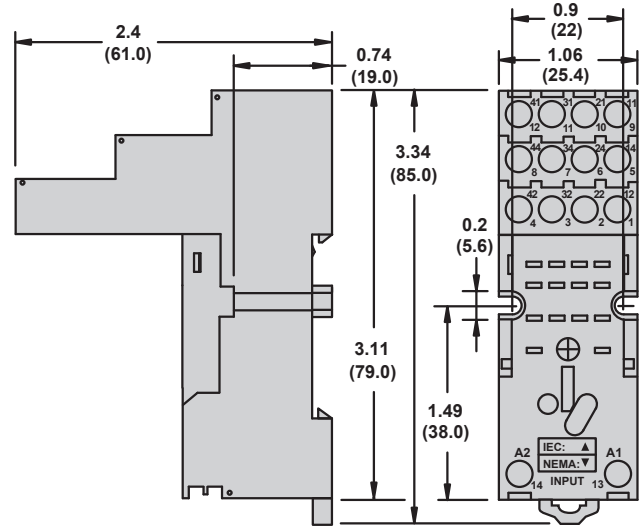

70-782E14-1

DIN/Panel Mount with Rising Elevator Box Terminals

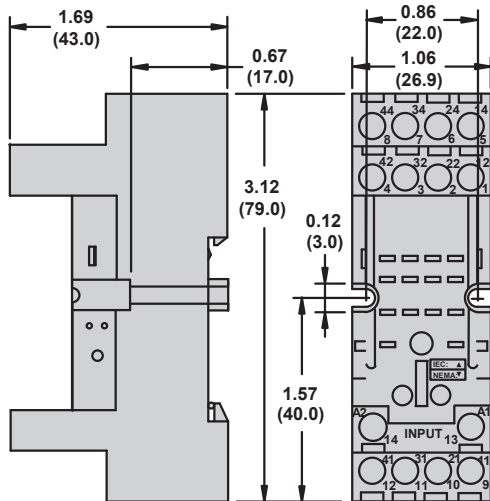

70-782D14-1

DIN/Panel Mount with Screw Terminals and Clamping Plates

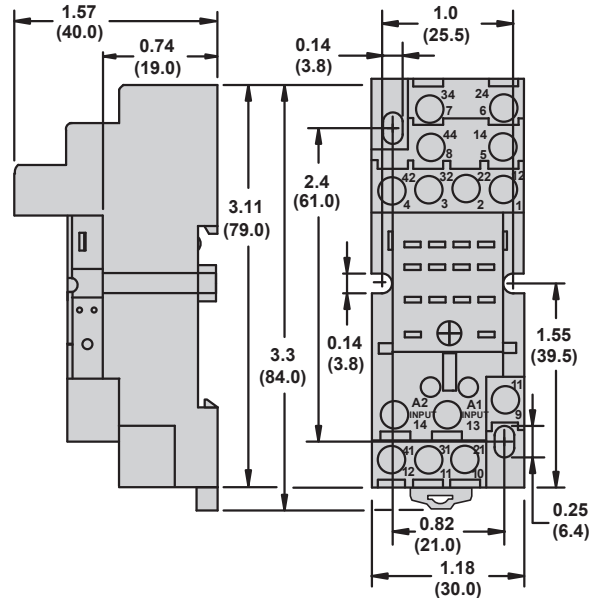

Magnecraft Time Delay and Sensor Relays

TDR782 Series Accessories

Dimensions — inches (millimeters)

70-461-1

DIN/Panel Mount with Screw Terminals and Clamping Plates

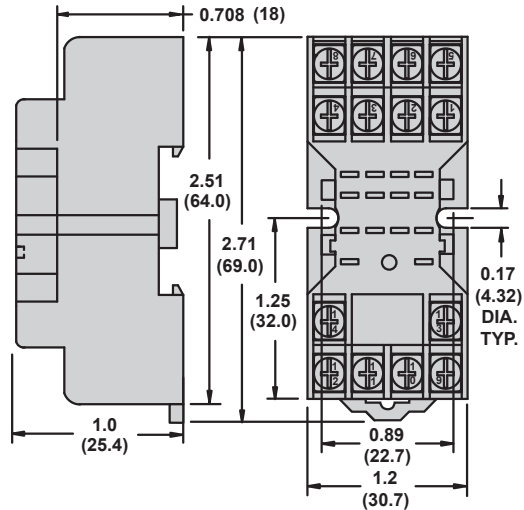

70-378-1

Solder Terminals for Chassis Mount

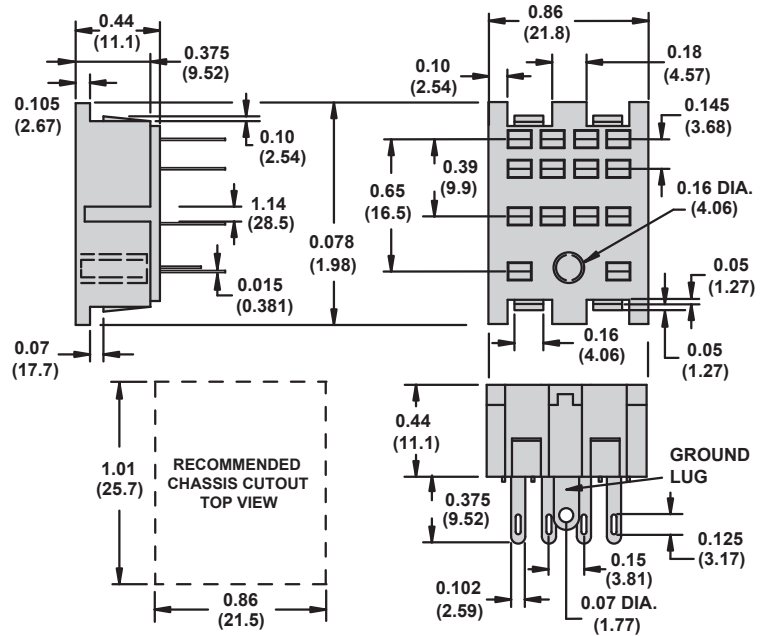

70-379-1

Printed Circuit Terminals

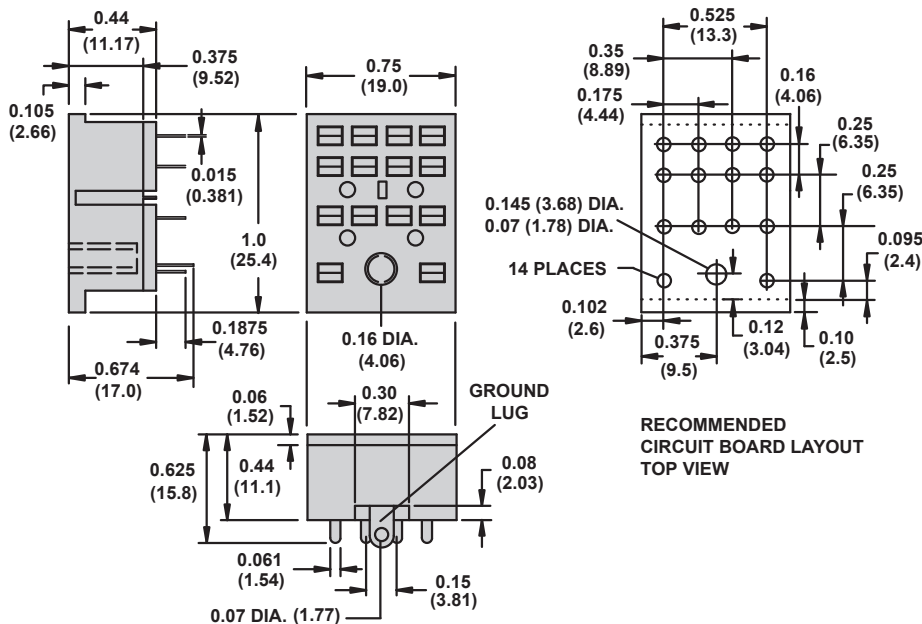

Wiring Diagrams

70-782EL8-1

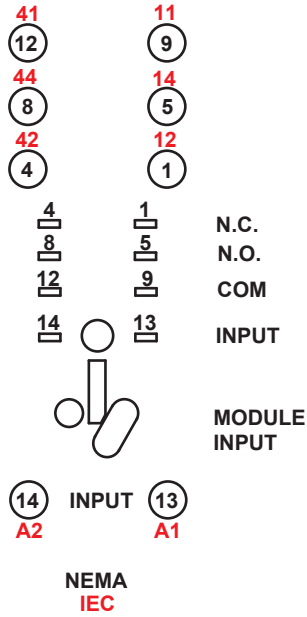

70-782EL14-1

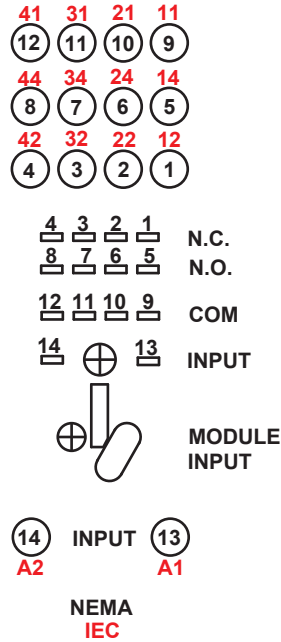

70-782E14-1

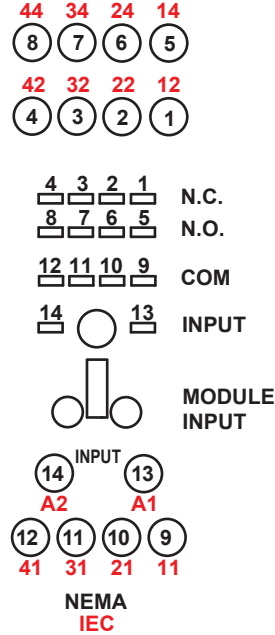

70-782D14-1

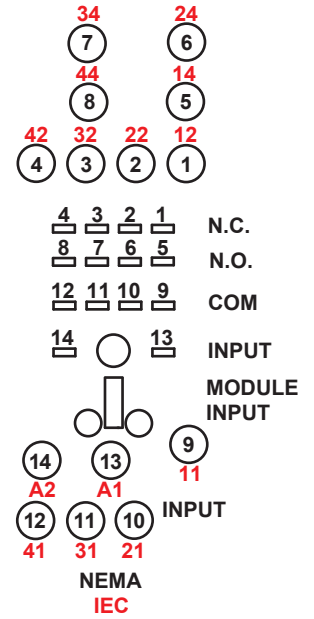

70-461-1

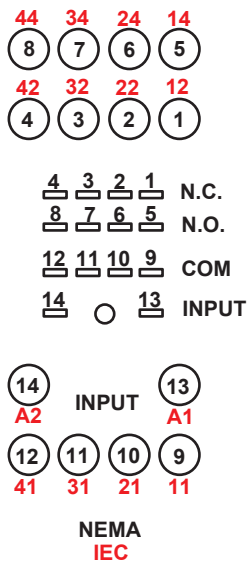

70-378-1

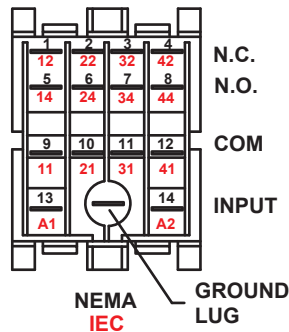

70-379-1

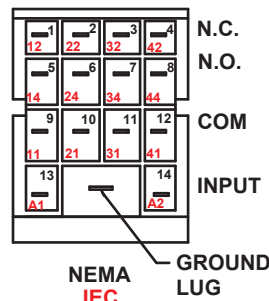

Description

Magnecraft Time Delay and Sensor Relays

TDRPRO Series

SPDT, 12 A; DPDT, 12 A



TDRPRO Relay

Description

Time delay relays that are programmable, multi-function, multi-voltage, and socket-compatible - offering the user the ultimate in design flexibility. The thumb wheel adjustment dials result in no mechanical deviation for supreme accuracy.

Feature	Benefit
Up to 10 functions	5 Timing functions controlled via supply voltage 4 Timing functions controlled via trigger input 1 function of memory latching
Broad timing range	0.1 Seconds to 9990 hours
Panel mount adapter	Panel mountable
Dust cover	Retains settings / keeps dust out
Universal power supply	12 – 240 Vac/Vdc
Thumb wheel adjustment for function / timing	Helps ensure accuracy and reduces timing deviations
2 LED status indicators	Indicate coil power / timing out / output state
RoHS compliant	Environmentally friendly

Input Voltage	Functions Available (1)	Timing Range	Contact Configuration	Rated Current (A)	Standard Part Number
12 to 240 Vac/Vdc	A,B,C,D,E,F,G,H,I,J	100 ms to 9990 hrs	DPDT	12	TDRPRO-5100
12 to 240 Vac/Vdc	A,B,C,D,E,F,G,H,I,J	100 ms to 9990 hrs	SPDT	12	TDRPRO-5101
12 to 240 Vac/Vdc	A,B,C	100 ms to 9990 hrs	DPDT	12	TDRPRO-5102

(1) For function descriptions, see pages 30 and 31.

Part Number Explanation

TDRPRO - 5100

Series: TDRPRO = 48 x 48 mm Time Delay Relay

Contact Configuration/# of Functions:
5100 = DPDT, 10 Functions
5101 = SPDT, 10 Functions
5102 = DPDT, 3 Functions

Magnecraft Time Delay and Sensor Relays

TDRPRO Series

SPDT, 12 A; DPDT, 12 A

Specifications

Part Number	TDRPRO-5100	TDRPRO-5101	TDRPRO-5102
Input Characteristics			
Input Voltage Range	12 to 240 Vac/Vdc	12 to 240 Vac/Vdc	12 to 240 Vac/Vdc
Operating Voltage	85% to 115% of Nominal	85% to 115% of Nominal	85% to 115% of Nominal
Maximum Power Consumption (AC)	2.5 VA	2.5 VA	2.5 VA
Maximum Power Consumption (DC)	2W	2W	2W
Output Characteristics			
Contact Configuration	DPDT	SPDT	DPDT
Output Current Rating	12 A	12 A	12 A
Contact Material	Silver Alloy	Silver Alloy	Silver Alloy
Switching Capabilities	12 A, 240 Vac, 50/60 Hz, 30 Vdc 1/3 HP @ 120 Vac 1/2 HP @ 240 Vac Pilot Duty B300	12 A, 240 Vac, 50/60 Hz, 30 Vdc 1/3 HP @ 120 Vac 1/2 HP @ 240 Vac Pilot Duty B300	12 A, 240 Vac, 50/60 Hz, 30 Vdc 1/3 HP @ 120 Vac 1/2 HP @ 240 Vac Pilot Duty B300
Minimum Switching Requirement	100 mA	100 mA	100 mA
Timing Characteristics			
Functions Available (1)	A,B,C,D,E,F,G,H,I,J	A,B,C,D,E,F,G,H,I,J	A,B,C
Time Scales	7	7	7
Time Ranges	0 to 999 by 0.1 sec 0 to 999 by sec 0 to 999 by 0.1 min 0 to 999 by min 0 to 999 by 0.1 hr 0 to 999 by hr 0 to 999 by 10 hr	0 to 999 by 0.1 sec 0 to 999 by sec 0 to 999 by 0.1 min 0 to 999 by min 0 to 999 by 0.1 hr 0 to 999 by hr 0 to 999 by 10 hr	0 to 999 by 0.1 sec 0 to 999 by sec 0 to 999 by 0.1 min 0 to 999 by min 0 to 999 by 0.1 hr 0 to 999 by hr 0 to 999 by 10 hr
Repeatability of the time delay @ constant voltage and temperature	0.1%	0.1%	0.1%
Reset Time	150 ms	150 ms	150 ms
Operate Time (3)	25 ms maximum	25 ms maximum	25 ms maximum
Release Time (3)	25 ms maximum	25 ms maximum	25 ms maximum
General Characteristics			
Electrical Life (operations at rated current) (2)	100,000 operations	100,000 operations	100,000 operations
Mechanical Life (Unpowered) (2)	10,000,000 operations	10,000,000 operations	10,000,000 operations
Dielectric Strength (Input to Contacts)	2500 Vrms	2500 Vrms	2500 Vrms
Storage Temperature Range	-30°C (-22°F) to +70°C (+158°F)	-30°C (-22°F) to +70°C (+158°F)	-30°C (-22°F) to +70°C (+158°F)
Operating Temperature Range	-20°C (-4°F) to +60°C (+140°F)	-20°C (-4°F) to +60°C (+140°F)	-20°C (-4°F) to +60°C (+140°F)
Weight	133 g (4.69 oz)	133 g (4.69 oz)	133 g (4.69 oz)
Input Indication	Green LED	Green LED	Green LED
Output Indication (Blinks = Timing or On = Energized)	RED LED	RED LED	RED LED
Enclosure Rating (according to IEC 60529 IP rating)	IP40	IP40	IP40
Approvals	cURus (File No. E43641), CE 61810-1, RoHS, cULus (UL Listed [File No. E43641] when used with Magnecraft socket 70-465)	cURus (File No. E43641), CE 61810-1, RoHS, cULus (UL Listed [File No. E43641] when used with Magnecraft socket 70-464)	cURus (File No. E43641), CE 61810-1, RoHS, cULus (UL Listed [File No. E43641] when used with Magnecraft socket 70-464)

(1) For function descriptions, see pages 30 and 31.

(2) Actual product life will vary based on electrical load, duty cycle, application, and environmental conditions.

(3) After the time delay period expires or upon trigger signal application (depends on selected function).

Magnecraft Time Delay and Sensor Relays

TDRPRO Series
SPDT, 12 A; DPDT, 12 A

Dimensions — inches (millimeters)

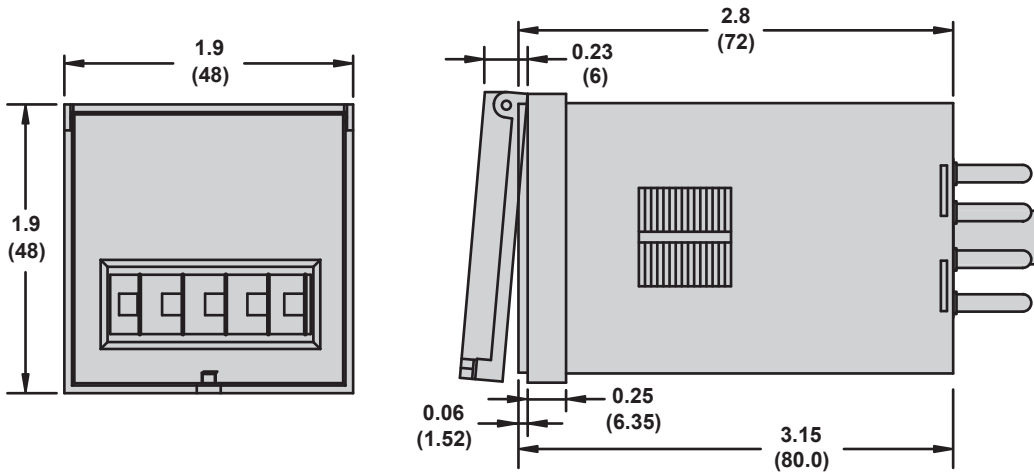

Wiring Diagrams

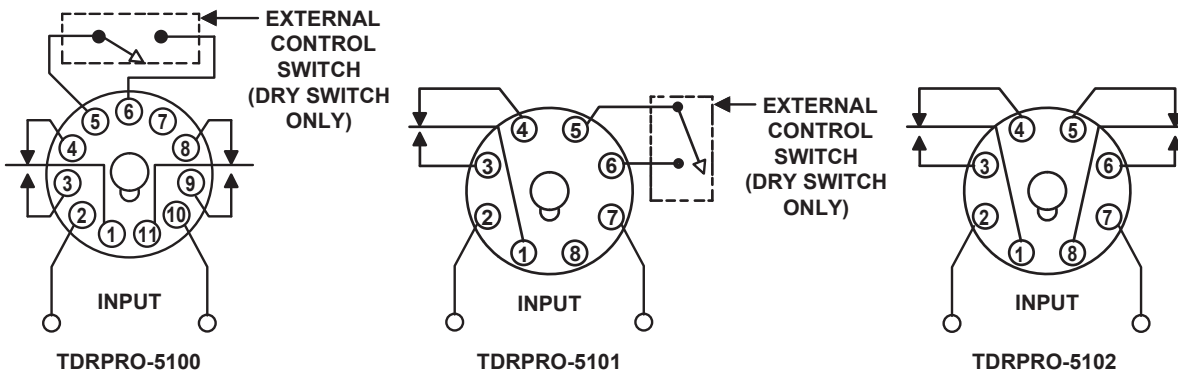

Magnecraft Time Delay and Sensor Relays

TDRPRO Series Accessories



Description

The TDR accessories create a complete system solution for all your application needs. The 70-750DL socket offers an alternate installation option for plug-in models. The 16-TDRPROSC retention clip holds the relay securely in place while allowing quick and efficient installation and maintenance.

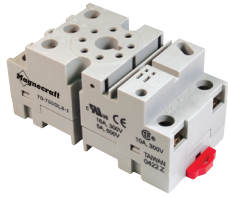

70-750DL8-1 Socket



70-750E8-1 Socket

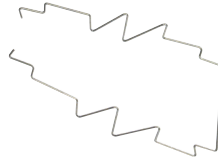

16-TDRPROSC Spring Clip



16-700DIN DIN Rail

Relay Accessories

Description	Function	For Use With Relays	Packaging Quantities	Standard Part Number
Socket	Mounts directly to DIN Rail or Panel	TDRPRO-5101, TDRPRO-5102	10	70-750DL8-1
Socket	Mounts directly to DIN Rail or Panel	TDRPRO-5100	10	70-750DL11-1
Socket	DIN/Panel Mount with Elevator Terminals	TDRPRO-5101, TDRPRO-5102	10	70-750E8-1
Socket	DIN/Panel Mount with Elevator Terminals	TDRPRO-5100	10	70-750E11-1
Socket	DIN/Panel Mount with Screw Terminals & Clamping Plates	TDRPRO-5100	10	70-465-1
Socket	DIN/Panel Mount with Screw Terminals & Clamping Plates	TDRPRO-5101, TDRPRO-5102	10	70-464-1
Socket	Panel Mount with Screw Terminals & Clamping Plates	TDRPRO-5100	10	70-170-1
Socket	Panel Mount with Screw Terminals & Clamping Plates	TDRPRO-5101, TDRPRO-5102	10	70-169-1
Metal Hold-Down Clip	Helps secure relay in socket	TDRPRO	10	16-TDRPROSC

Socket Accessories

Description	Function	For Use With Sockets	Packaging Quantities	Standard Part Number
Metal DIN Rail	Quick installation and removal of sockets	(See table above.)	10 (1)	16-700DIN
ID Tags	Allows for identification of circuits in mult-relay applications	70-750E8-1 70-750E11-1	10	16-750/782FT-1

(1) Length is 39.3 inches.

Magnecraft Time Delay and Sensor Relays

TDRPRO Series Accessories

Specifications

Part Number	70-750DL8-1	70-750DL11-1	70-750E8-1	70-750E11-1
Contact Configuration	DPDT	3PDT	DPDT	3PDT
Number of Terminals	8	11	8	11
Mounting Style	Panel / DIN rail	Panel / DIN rail	Panel / DIN rail	Panel / DIN rail
Current Rating	16 A	5 A	12 A	12 A
Nominal Voltage Rating	300 V	600 V	600 V	300 V
Temperature Storage Range	-40°C (-40°F) to +105°C (+221°F)	-40°C (-40°F) to +105°C (+221°F)	-40°C (-40°F) to +105°C (+221°F)	-40°C (-40°F) to +105°C (+221°F)
Protection Category according to IEC 60529 IP rating (Fingersafe)	IP 20	IP 20	IP 20	IP 20
Internal Metal Tracks	Copper Alloy, Zinc Plated	Copper Alloy, Zinc Plated	Copper Alloy, Zinc Plated	Copper Alloy, Zinc Plated
Screw Terminals	Steel, Zinc Plated	Steel, Zinc Plated	Steel, Zinc Plated	Steel, Zinc Plated
Screw Style	Combination Head	Combination Head	Combination Head	Combination Head
Screw Size	M3.5 mm	M3.5 mm	M3.5 mm	M3.5 mm
Maximum Screw Torque	9 lb-in (1.0 N•m)	9 lb-in (1.0 N•m)	9 lb-in (1.0 N•m)	9 lb-in (1.0 N•m)
Terminal Connection	Screw Clamping	Screw Clamping	Elevator	Elevator
Terminal Layout	Logic	Logic	Non-Logic	Non-Logic
Maximum Wire Size	Solid Cu 12 / 14 (2) AWG, 4 / 2.5 (2) mm ² Stranded Cu 12 / 14 (2) AWG, 4 / 2.5 (2) mm ²	Solid Cu 12 / 14 (2) AWG, 4 / 2.5 (2) mm ² Stranded Cu 12 / 14 (2) AWG, 4 / 2.5 (2) mm ²	Solid Cu 12 / 14 (2) AWG, 4 / 2.5 (2) mm ² Stranded Cu 12 / 14 (2) AWG, 4 / 2.5 (2) mm ²	Solid Cu 12 / 14 (2) AWG, 4 / 2.5 (2) mm ² Stranded Cu 12 / 14 (2) AWG, 4 / 2.5 (2) mm ²
DIN Rail Mounting, EN 60715	35 mm (1.38 in)	35 mm (1.38 in)	35 mm (1.38 in)	35 mm (1.38 in)
Chassis Mount Screw Torque	7 lb-in (0.8 N•m)	7 lb-in (0.8 N•m)	7 lb-in (0.8 N•m)	7 lb-in (0.8 N•m)
Flammability Rating	94V-0 Class	94V-0 Class	94V-0 Class	94V-0 Class
Body Color	Light Gray	Light Gray	Light Gray	Light Gray
DIN Locking Method	Red Plastic Locking Clip	Red Plastic Locking Clip	Red Plastic Locking Clip	Red Plastic Locking Clip
Agency Approvals	cURus (File No. E70550), CSA (File No. 40787), CE 60947-1, RoHS	cURus (File No. E70550), CSA (File No. 40787), CE 60947-1, RoHS	cURus (File No. E70550), CSA (File No. 40787), CE 60947-1, RoHS	cURus (File No. E70550), CSA (File No. 40787), CE 60947-1, RoHS

Part Number	70-169-1	70-170-1	70-464-1	70-465-1
Contact Configuration	DPDT	3PDT	DPDT	3PDT
Number of Terminals	8	11	8	11
Mounting Style	Panel	Panel	Panel / DIN rail	Panel / DIN rail
Current Rating	15 A	15 A	15/10 A	15/5 A
Nominal Voltage Rating	300 V	600 V	300/600 V	300/600 V
Temperature Storage Range	-40°C (-40°F) to +105°C (+221°F)	-40°C (-40°F) to +105°C (+221°F)	-40°C (-40°F) to +105°C (+221°F)	-40°C (-40°F) to +105°C (+221°F)
Internal Metal Tracks	Copper Alloy, Zinc Plated	Copper Alloy, Zinc Plated	Copper Alloy, Zinc Plated	Copper Alloy, Zinc Plated
Screw Terminals	Steel, Zinc Plated	Steel, Zinc Plated	Steel, Zinc Plated	Steel, Zinc Plated
Screw Style	Combination Head	Combination Head	Combination Head	Combination Head
Screw Size	M3.5 mm	M3.5 mm	M3.5 mm	M3.5 mm
Maximum Screw Torque	9 lb-in (1.0 N•m)	9 lb-in (1.0 N•m)	9 lb-in (1.0 N•m)	9 lb-in (1.0 N•m)
Terminal Connection	Screw Clamping	Screw Clamping	Screw Clamping	Screw Clamping
Terminal Layout	Non-Logic	Non-Logic	Non-Logic	Non-Logic
Maximum Wire Size	Solid Cu 12 / 14 (2) AWG, 4 / 2.5 (2) mm ² Stranded Cu 12 / 14 (2) AWG, 4 / 2.5 (2) mm ²	Solid Cu 12 / 14 (2) AWG, 4 / 2.5 (2) mm ² Stranded Cu 12 / 14 (2) AWG, 4 / 2.5 (2) mm ²	Solid Cu 12 / 14 (2) AWG, 4 / 2.5 (2) mm ² Stranded Cu 12 / 14 (2) AWG, 4 / 2.5 (2) mm ²	Solid Cu 12 / 14 (2) AWG, 4 / 2.5 (2) mm ² Stranded Cu 12 / 14 (2) AWG, 4 / 2.5 (2) mm ²
DIN Rail Mounting, EN 60715	35 mm (1.38 in)	35 mm (1.38 in)	35 mm (1.38 in)	35 mm (1.38 in)
Chassis Mount Screw Torque	7 lb-in (0.8 N•m)	7 lb-in (0.8 N•m)	7 lb-in (0.8 N•m)	7 lb-in (0.8 N•m)
Flammability Rating	94V-0 Class	94V-0 Class	94V-0 Class	94V-0 Class
Body Color	Light Gray	Light Gray	Light Gray	Light Gray
DIN Locking Method	–	–	Red Plastic Locking Clip	Red Plastic Locking Clip
Product Certifications	cURus (File No. E70550), CSA (File No. 97877), CE 60947-1, RoHS	cURus (File No. E70550), CSA (File No. 97877), CE 60947-1, RoHS	cURus (File No. E70550), CSA (File No. 97877), CE 60947-1, RoHS	cURus (File No. E70550), CSA (File No. 97877), CE 60947-1, RoHS

Dimensions — inches (millimeters)

70-750DL8-1
Mounts directly to DIN Rail or Panel

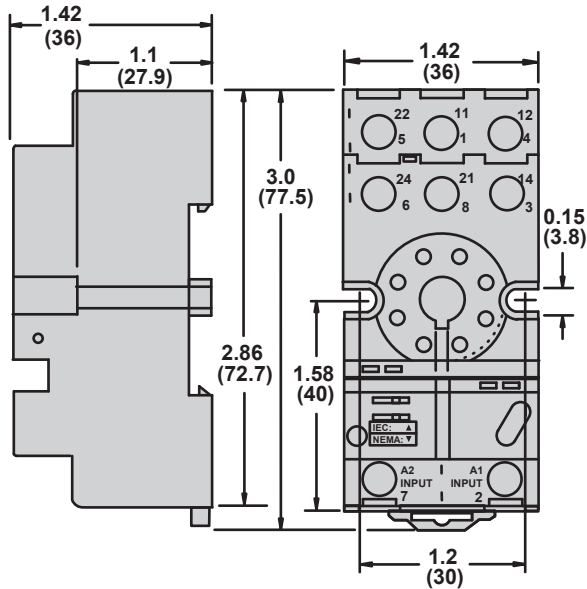

70-750DL11-1
Mounts directly to DIN Rail or Panel

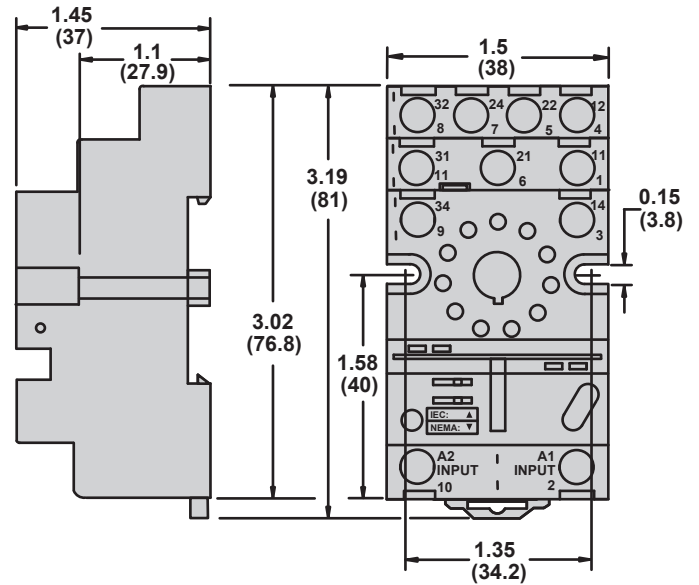

70-750E8-1
DIN/Panel Mount with Elevator Terminals

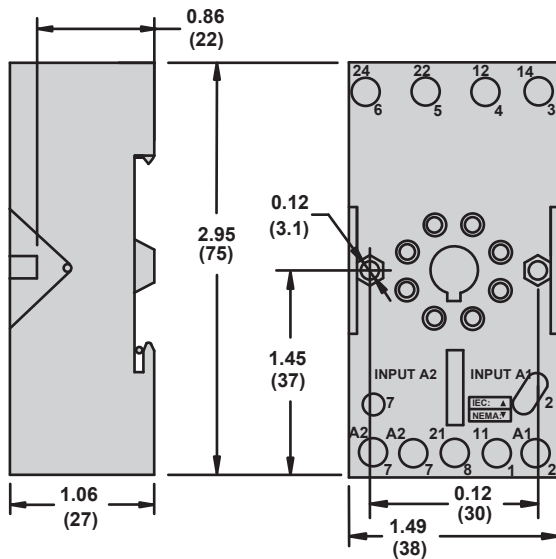

70-750E11-1
DIN/Panel Mount with Elevator Terminals

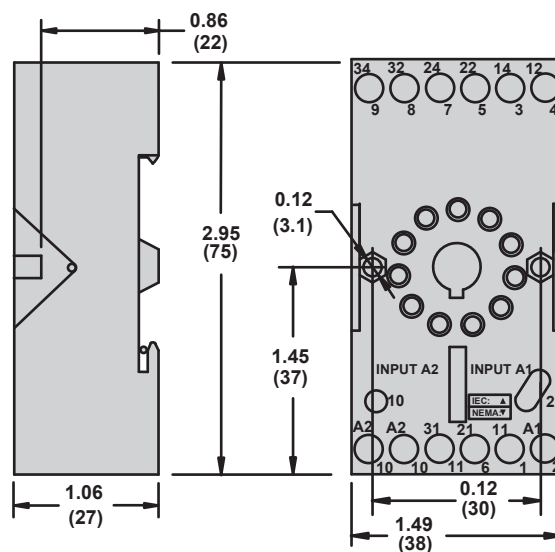

Magnecraft Time Delay and Sensor Relays

TDRPRO Series Accessories

Dimensions — inches (millimeters)

70-465-1

DIN/Mount with Screw Terminals & Clamping Plates

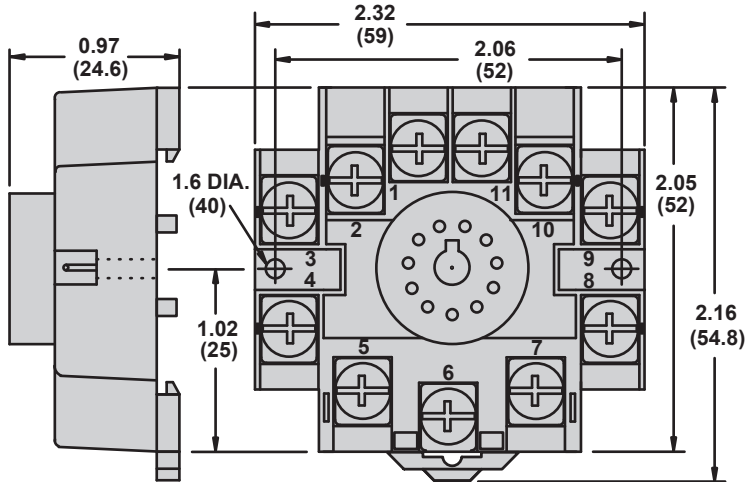

70-170-1

Panel Mount with Screw Terminals & Clamping Plates

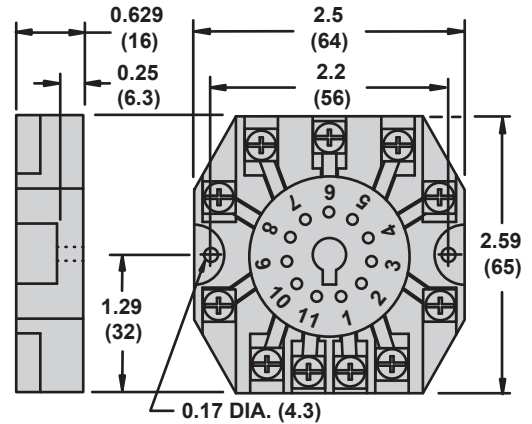

70-464-1

DIN/Mount with Screw Terminals & Clamping Plates

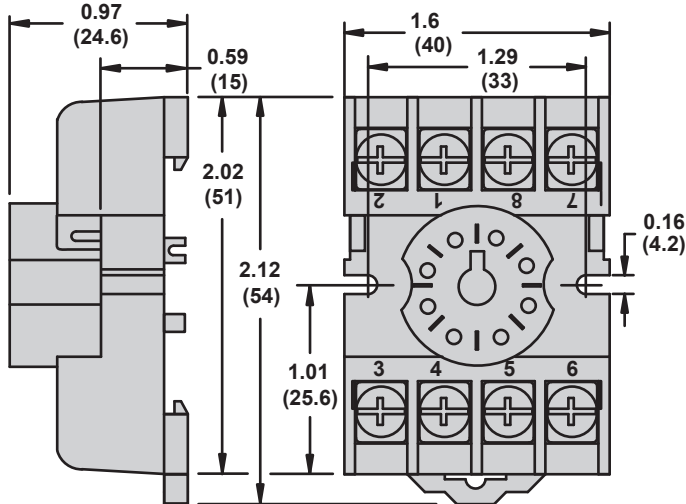

70-169-1

Panel Mount with Screw Terminals & Clamping Plates

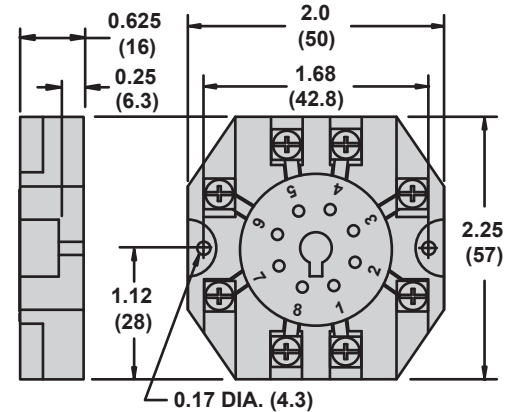

Wiring Diagrams

70-750E8-1

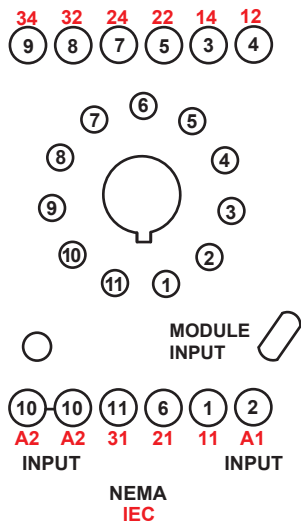

70-750E11-1

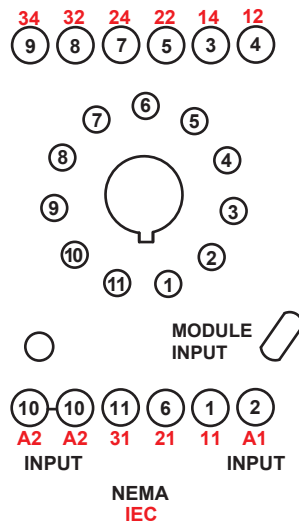

70-750DL8-1

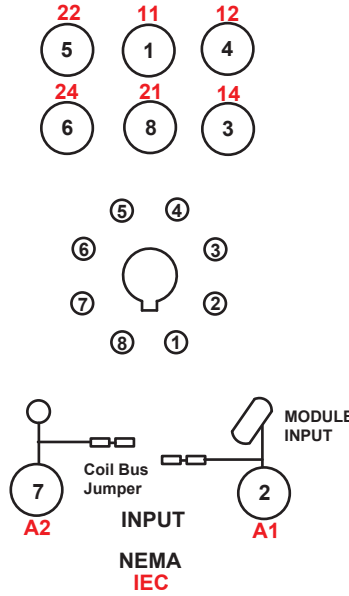

70-750DL11-1

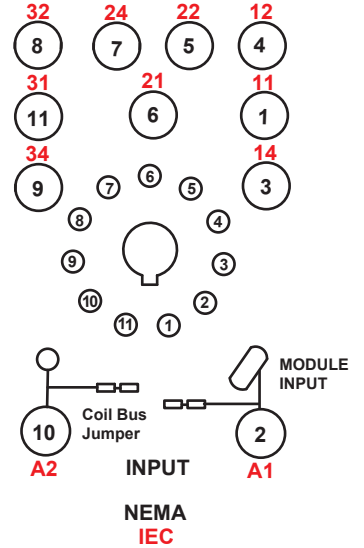

70-465-1

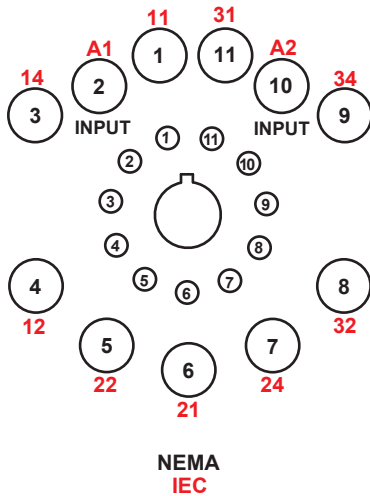

70-464-1

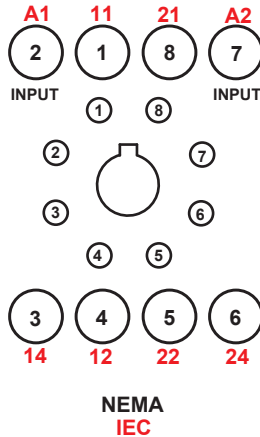

70-170-1

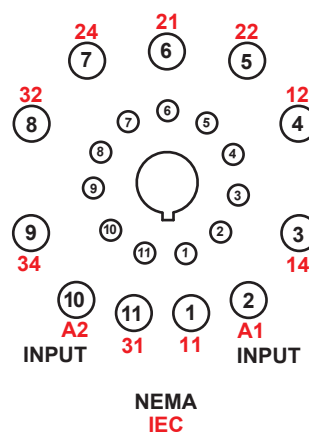

70-169-1

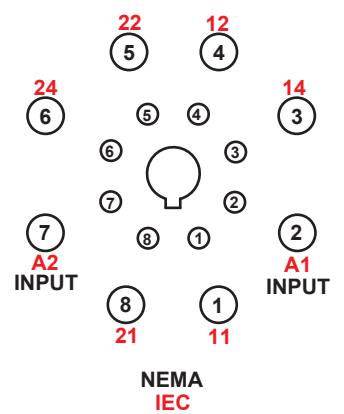

Time Delay Relay Functions: Power Trigger

Function	Description	Timing Chart	Relays
On Delay (A)	<ul style="list-style-type: none"> When the input voltage U is applied, timing delay T begins. Relay contacts R change state after time delay is complete. Contacts R return to their shelf state when input voltage U is removed. Trigger switch is not used in this function. 		<ul style="list-style-type: none"> 821, 822, TDR782, TDRPRO-5100, TDRPRO-5101, TDRPRO-5102, 831, 841
Repeat Cycle: Starting Open (B)	<ul style="list-style-type: none"> When input voltage U is applied, time delay T begins. When time delay T is complete, relay contacts R change state for time delay T. This cycle will repeat until input voltage U is removed. Trigger switch is not used in this function. 		<ul style="list-style-type: none"> 821, 822, TDRPRO-5100, TDRPRO-5101, TDRPRO-5102
Interval (C)	<ul style="list-style-type: none"> When input voltage U is applied, relay contacts R change state immediately and timing cycle begins. When time delay T is complete, contacts return to shelf state. When input voltage U is removed, contacts will also return to their shelf state. Trigger switch is not used in this function. 		<ul style="list-style-type: none"> 821, 822, TDRPRO-5100, TDRPRO-5101, TDRPRO-5102
Repeat Cycle: Starting Closed (F)	<ul style="list-style-type: none"> When input voltage U is applied, relay contacts R change state immediately and time delay T begins. When time delay T is complete, contacts return to their shelf state for time delay T. This cycle will repeat until input voltage U is removed. Trigger switch is not used in this function. 		<ul style="list-style-type: none"> 821, 822, TDRPRO-5100, TDRPRO-5101
Pulse Generator (G)	<ul style="list-style-type: none"> Upon application of input voltage U, a single output pulse of 0.5 seconds is delivered to relay after time delay T. Power must be removed and reapplied to repeat pulse. Trigger switch is not used in this function. 		<ul style="list-style-type: none"> 821, 822, TDRPRO-5100, TDRPRO-5101

Timing Chart Key

U = Input voltage (Power supply)

R = Relay contacts

T = Setting time

Time Delay Relay Functions: Switch Trigger

Function	Description	Timing Chart	Relays
Off Delay (D)	<ul style="list-style-type: none"> Input voltage U must be applied continuously. When trigger switch S is closed, relay contacts R change state. When trigger switch S is opened, delay T begins. When delay T is complete, contacts R return to their shelf state. If trigger switch S is closed before time delay T is complete, then time is reset. When trigger switch S is opened, the delay begins again, and relay contacts R remain in their energized state. If input voltage U is removed, relay contacts R return to their shelf state. 		<ul style="list-style-type: none"> 821, 822, TDRPRO-5100, TDRPRO-5101, TDRPRO-5102
Retriggerable One Shot (E)	<ul style="list-style-type: none"> Upon application of input voltage U, the relay is ready to accept trigger signal S. Upon application of the trigger signal S, the relay contacts R transfer and the preset time T begins. At the end of the preset time T, the relay contacts R return to their normal condition unless the trigger switch S is opened and closed prior to time out T (before preset time elapses). Continuous cycling of the trigger switch S at a rate faster than the preset time will cause the relay contacts R to remain closed. If input voltage U is removed, relay contacts R return to their shelf state. 		<ul style="list-style-type: none"> 821, 822, TDRPRO-5100, TDRPRO-5101, TDRPRO-5102
One Shot (H)	<ul style="list-style-type: none"> Upon application of input voltage U, the relay is ready to accept trigger signal S. Upon application of the trigger signal S, the relay contacts R transfer and the preset time T begins. During time-out, the trigger signal S is ignored. The relay resets by applying the trigger switch S when the relay is not energized. 		<ul style="list-style-type: none"> 821, 822, TDRPRO-5100, TDRPRO-5101
On and Off Delay (I)	<ul style="list-style-type: none"> Input voltage U must be applied continuously. When trigger switch S is closed, time delay T begins. When time delay T is complete, relay contacts R change state and remain transferred until trigger switch S is opened. If input voltage U is removed, relay contacts R return to their shelf state. 		<ul style="list-style-type: none"> 821, 822, TDRPRO-5100, TDRPRO-5101
Memory Latch (J)	<ul style="list-style-type: none"> Input voltage U must be applied continuously. Output changes state with every trigger switch S closure. If input voltage U is removed, relay contacts R return to their shelf state. 		<ul style="list-style-type: none"> 821, 822, TDRPRO-5100, TDRPRO-5101

Timing Chart Key

- U** = Input voltage (Power supply)
- S** = Switch trigger (Control switch)
- R** = Relay contacts
- T** = Setting time

Magnecraft Time Delay and Sensor Relays

Definition

A time delay is defined as the controlled period between the functioning of two events. A time delay relay is a combination of an electromechanical output relay and a control circuit. The control circuit is comprised of solid state components that control operation of the relay and timing range. Typical time delay functions include On-Delay, Repeat cycle (starting off), Interval, Off-Delay, Retriggerable One Shot, Repeat cycle (starting on), Pulse Generator, One Shot, On/Off Delay, and Memory Latch. Each function is explained in the tables on pages 30 and 31. Time delay relays have a broad choice of timing ranges from less than one second to many days. There are many choices of timing adjustments from calibrated external knobs, DIP switches, thumbwheel switches, or recessed potentiometer.

Principle of Operation

Time delay relays are simply control relays with a time delay built in. Their purpose is to control an event based on time. The difference between relays and time delay relays is when the output contacts open & close: on a control relay, it happens when voltage is applied and removed from the coil; on time delay relays, the contacts will open or close before or after a pre-selected, timed interval.

Typically, time delay relays are initiated or triggered by one of two methods:

- application of input voltage (On Delay, Interval On, Flasher, Repeat Cycle, Delayed Interval & Interval/Flasher).
- opening or closing of a trigger signal (Off Delay, Single Shot & Watchdog).

These trigger signals can be one of two designs:

- a control switch (dry contact), i.e., limit switch, push button, float switch, etc.
- voltage (commonly known as a power trigger).

Definitions:

Input Voltage: Control voltage applied to the input terminals (see wiring diagrams below). Depending on the function, input voltage will either initiate the unit or make it ready to initiate when a trigger signal is applied.

Trigger Signal: On certain timing functions, a trigger signal is used to initiate the unit after input voltage has been applied. As noted above, this trigger signal can either be a control switch (dry contact switch) or a power trigger (voltage).

Output (Load): Every time delay relay has an internal relay (usually mechanical) with contacts that open & close to control the load. They are represented by the dotted lines in the wiring diagrams. Note that the user must provide the voltage to power the load being switched by the output contacts of the time delay relay.

Magnecraft Time Delay and Sensor Relays

Applications

Magnecraft time delay and sensor relays are designed to provide cost effective solutions for your industrial timing and sensing needs. Available in a wide array of forms, fits and functions; Magnecraft timers offer flexibility and performance for process control and industrial building applications.

Typical Examples of Timer Applications

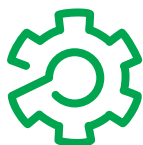

Automation Panels

Process controls, motor controls, emergency lighting



Food & Beverage

Commercial/industrial cooking equipment, filtration systems, bottling, chillers, convection ovens



Packaging Machinery

Conveyor motors, food processors, product/shrink wrap, solenoid controls



Lighting Control

Traffic signal systems, motorway information systems, theatrical lighting, ballast lighting



Power Supplies

Universal power supplies, battery backup systems



Material Handling

Motor control, conveyor controls



HVAC & Refrigeration

Anti-condensation equipment, compressor controls, blower controls, motorized duct/vent controls



Appliances

Air conditioners, water heaters, portable heaters, spa controls, water pumps

Magnecraft Time Delay and Sensor Relays

The Magnecraft website (www.serelays.com) is designed to enable users to easily find the proper relay to fit design requirements and to help simplify and shorten workflow.

Easily find the proper relay to fit design requirements

Online Catalog

Find the right product by choosing specifications, compare products side-by-side, and view technical specifications, 2D and 3D drawings, and associated accessories.

Cross Reference Search

Search our comprehensive database to identify products by manufacturer and part number, and link directly to part specifications.

3D CAD Library

View, email, download, or insert a file directly into your open CAD software. There are 18 different file formats to choose from.

Order Free Samples

Magnecraft offers free samples as a courtesy to individuals and companies evaluating our products for their designs and applications. Sample orders are subject to approval.

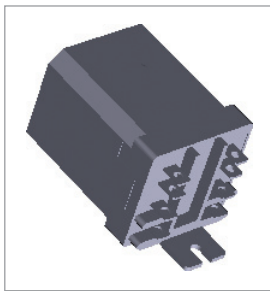

3D Models

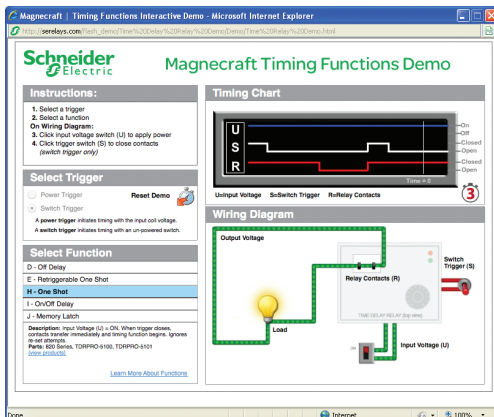

Time Delay Relay Demo

Simplify and shorten workflow

Interactive Tools

View interactive demonstrations; such as our Time Delay Relay Interactive Demo (left) which visually demonstrates the ten different timing functions offered on Magnecraft time delay relays.

Distributor Inventory Search

Search authorized distributors' current Magnecraft inventory and buy online. (Buy online not available for all distributors).

16-700DIN	13
	17
	28
16-750/782FT-1	28
16-782FT-1	17
16-788C1	13
16-1344	28
16-TDR782SC	17
16-TDRPROSC	28
70-169-1	28
70-170-1	28
70-378-1	17
70-379-1	17
70-461-1	17
	28
70-463-1	28
70-465-1	28
70-750DL11-1	28
70-750DL8-1	28
70-750E11-1	28
70-750E8-1	28
70-782D14-1	17
70-782E14-1	17
70-782EL14-1	17
70-782EL8-1	17
821TD10H-UNI	4
822TD10H-UNI	4
831VS-120A	7
831VS-240A	7
831VS-24D	7
841CS1-UNI	10
841CS2-UNI	10
841CS5-UNI	10
841CS8-UNI	10
TDR782XBXA-110A	14
TDR782XBXA-24A	14
TDR782XBXA-24D	14
TDR782XDXA-110A	14
TDR782XDXA-12D	14
TDR782XDXA-230A	14
TDR782XDXA-24A	14
TDR782XDXA-24D	14
TDRPRO-5100	22
TDRPRO-5101	22
TDRPRO-5102	22

Schneider Electric USA, Inc.

1300 S. Wolf Rd.
Des Plaines, IL 60018
Tel: 847-441-2540
www.serelays.com

Electrical equipment should be installed, operated, serviced, and maintained only by qualified personnel. No responsibility is assumed by Schneider Electric for any consequences arising out of the use of this material.

© 2012–2015 Schneider Electric. All Rights Reserved. Schneider Electric and Magnecraft are trademarks and the property of Schneider Electric SE, its subsidiaries and affiliated companies. All other trademarks are the property of their respective owners.

8501CT1104R01/15
Replaces 8501CT1104R01/12, 01/2012

Данный компонент на территории Российской Федерации

Вы можете приобрести в компании MosChip.

Для оперативного оформления запроса Вам необходимо перейти по данной ссылке:

<http://moschip.ru/get-element>

Вы можете разместить у нас заказ для любого Вашего проекта, будь то серийное производство или разработка единичного прибора.

В нашем ассортименте представлены ведущие мировые производители активных и пассивных электронных компонентов.

Нашей специализацией является поставка электронной компонентной базы двойного назначения, продукции таких производителей как XILINX, Intel (ex.ALTERA), Vicor, Microchip, Texas Instruments, Analog Devices, Mini-Circuits, Amphenol, Glenair.

Сотрудничество с глобальными дистрибьюторами электронных компонентов, предоставляет возможность заказывать и получать с международных складов практически любой перечень компонентов в оптимальные для Вас сроки.

На всех этапах разработки и производства наши партнеры могут получить квалифицированную поддержку опытных инженеров.

Система менеджмента качества компании отвечает требованиям в соответствии с ГОСТ Р ИСО 9001, ГОСТ РВ 0015-002 и ЭС РД 009

Офис по работе с юридическими лицами:

105318, г.Москва, ул.Щербаковская д.3, офис 1107, 1118, ДЦ «Щербаковский»

Телефон: +7 495 668-12-70 (многоканальный)

Факс: +7 495 668-12-70 (доб.304)

E-mail: info@moschip.ru

Skype отдела продаж:

moschip.ru

moschip.ru_4

moschip.ru_6

moschip.ru_9