



User Manual – AS5x40/AS5x45-AB-v2.1

AS5x40/AS5x45

**10-bit Rotary Position Sensor with Digital Angle
(Interface), ABI, UVW and PWM output**



Table of Contents

1	General Description	3
2	The AS5040 adapter board.....	3
2.1	Board description	3
2.2	Mounting the AS5040 adapter board	4
3	AS5040 Adapterboard and pinout.....	6
4	Operation cases	8
4.1	Standalone SSI output mode	8
4.2	Standalone PWM output mode	9
4.3	Standalone incremental Output	10
4.4	Daisy chain mode.....	12
5	Programming the AS5040.....	13
6	AS5040 differences to AS5045.....	14
7	AS5040 AB-Hardware.....	15
7.1	AS5040-AB-2.1 schematics	15
7.2	AS5040 – AB – 2.1 PCB layout	15
8	Copyright.....	16
9	Disclaimer	16
10	Contact Information.....	16

Revision History

Revision	Date	Owner	Description
1.0	01.10.2009		Initial revision
1.3	05.07.2013	azen	Updated to new template
1.4	09.08.2013	azen	Minor corrections



1 General Description

The AS5x40/AS5x45 series are contactless magnetic position sensors for accurate angular measurement over a full turn of 360°. They are system-on-chip, combining integrated Hall elements, analog front end and digital signal processing in a single device.

To measure the angle, only a simple two-pole magnet, rotating over the center of the chip, is required. The magnet may be placed above or below the IC. (See Figure 1:)

Figure 1:
Rotary Position Sensor AS5040 + Magnet

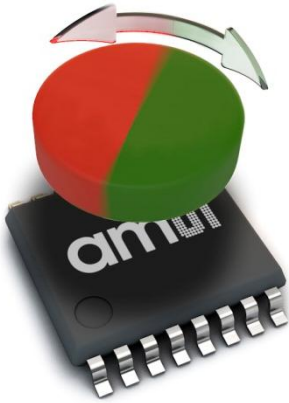

2 The AS5040 adapter board

The AS5040 adapter board is a simple circuit allowing test and evaluation of the AS5x40/AS5x45 position sensor without building a test fixture or PCB.

2.1 Board description

The PCB can be used as standalone unit or attached to a microcontroller. The standalone operation requires a 5V power supply only; the magnet's angle can be read on the PWM or analog output. (See Figure 2:).



Figure 2:
AS5040 Adapterboard

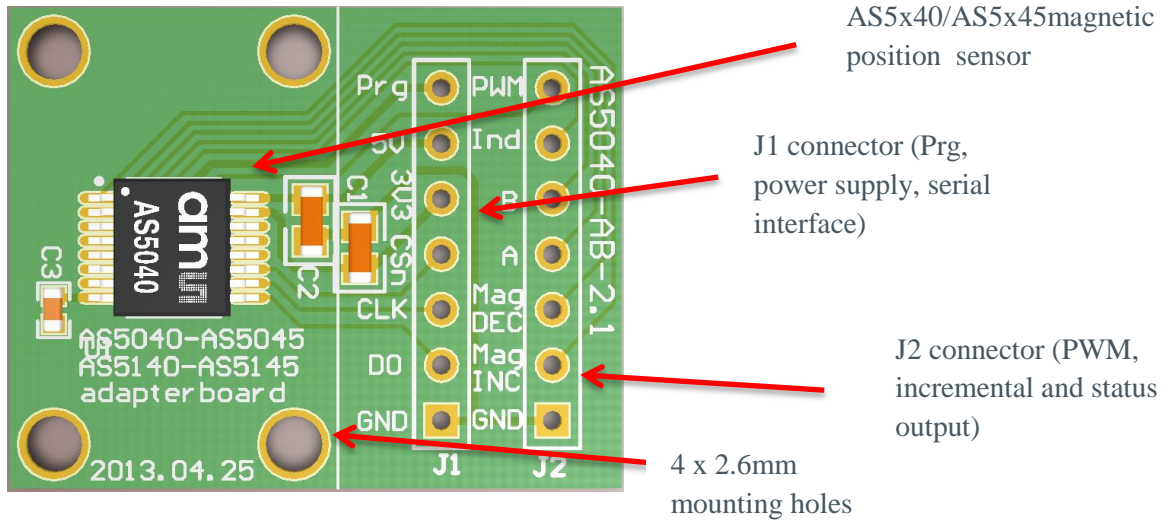

2.2 Mounting the AS5040 adapter board

A diametric magnet must be placed over on under the AS5x40/AS5x45 sensor and should be centered on the middle of the package with a tolerance of 0.5mm.

The airgap between the magnet and the sensor casing should be maintained in the range 0.5mm~2mm. The magnet holder must not be ferromagnetic. Materials as brass, copper, aluminum, stainless steel are the best choices to make this part. (See Figure 3:)

Figure 3:
AS5040 adapter board mounting and dimension

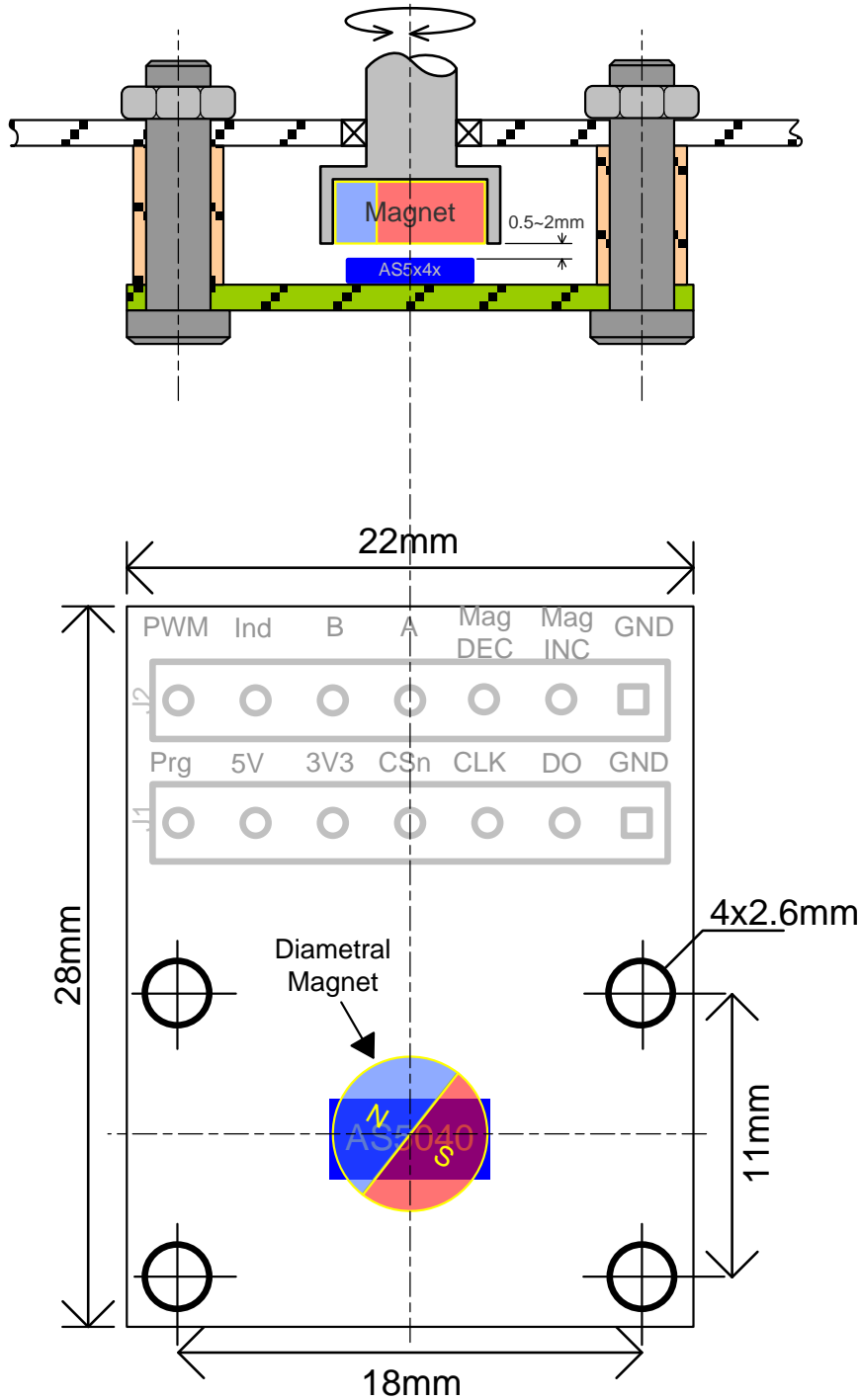



3 AS5040 Adapterboard and pinout

The Adapterboard Pinout is shown below.

Figure 4:
AS5040 adapter board connectors and sensor pinout

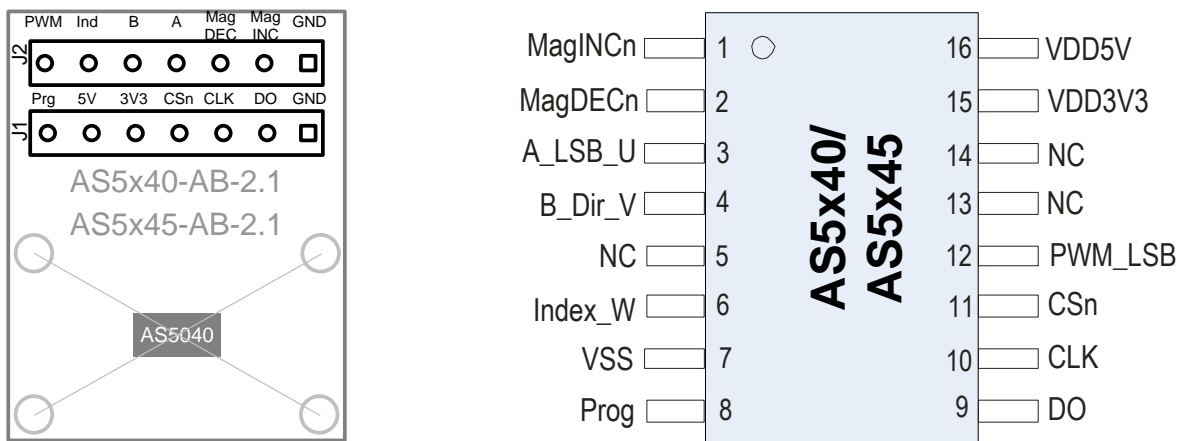

Table 1:
Pin description

Pin# Board	Pin# AS5x40 AS5x45	Symbol Board	Type	Description
JP1 - 1	7	GND	S	Supply ground
JP1 - 2	9	DO	DO_T	Data Output of Synchronous Serial Interface
JP1 - 3	10	CLK	DI_ST	Clock Input of Synchronous Serial Interface; Schmitt-Trigger input
JP1 - 4	11	CSn	DI_PU_ST	Chip Select, active low; Schmitt-Trigger input, internal pull-up resistor (~50kΩ) connect to VSS in incremental mode
JP1 - 5	15	3V3	S	3V-Regulator Output
JP1 - 6	16	5V	S	5V Supply
JP1 - 7	8	Prg	DI_PD	OTP Programming Input and Data Input for Daisy Chain mode. Internal pull-down resistor (~74kΩ). May be connected to VSS if programming is not used
JP2 - 1	7	GND	S	Supply ground
JP2 - 2	1	MagINC	DO_OD	Magnet Field Magnitude INC rease; active low, indicates a distance reduction between the magnet and the device surface.
JP2 - 3	2	MagDEC	DO_OD	Magnet Field Magnitude DEC rease; active low, indicates a distance increase between the device and the magnet
JP2 - 4	3	A	DO	AS5040 – AS5140 – AS5145 (programmed) only Mode1.x: Quadrature A channel Mode2.x: Least Significant Bit



Pin# Board	Pin# AS5x40 AS5x45	Symbol Board	Type	Description
---------------	--------------------------	-----------------	------	-------------

Mode3.x: U signal (phase1)

JP2 - 5	4	B	DO	<i>AS5040 – AS5140 – AS5145 (programmed) only</i> <i>Mode1.x: Quadrature B channel quarter period shift to channel A.</i> <i>Mode2.x: Direction of Rotation</i> <i>Mode3.x: V signal (phase2)</i>
JP2 - 6	6	Ind	DO	<i>AS5040 – AS5140 – AS5145 (programmed) only</i> <i>Mode1.x and Mode2.x : Index signal indicates the absolute zero position</i> <i>Mode3.x: W signal (phase3)</i> <i>AS5045 – AS5145 (unprogrammed)</i> <i>Mode input, connect to VDD5 (Fast mode) or GND (Slow mode); do not change during operation</i>
JP2 - 7	12	PWM	DO	Pulse Width Modulation of approx. 1kHz; LSB in <i>Mode3.x</i>

Pin types:	DO_OD	digital output open drain	S	supply pin
	DI_PD	digital input pull-down	DO_T	digital output /tri-state
	DI_PU	digital input pull-up	ST	schmitt-trigger input
	DI	digital input	DO	digital output

4 Operation cases

The most complete and accurate solution for a MCU to read the angle of a magnet is the serial interface.

4.1 Standalone SSI output mode

The serial word contains 16 bits for AS5x40 or 18 bits for AS5x45 and consists of 10 bit (AS5x40) or 12 bit (AS5x45) angle value and some other indicator bits like MagINC, MagDEC, which can be read at the same time.

Figure 5:
Using the analog output with the adapter board

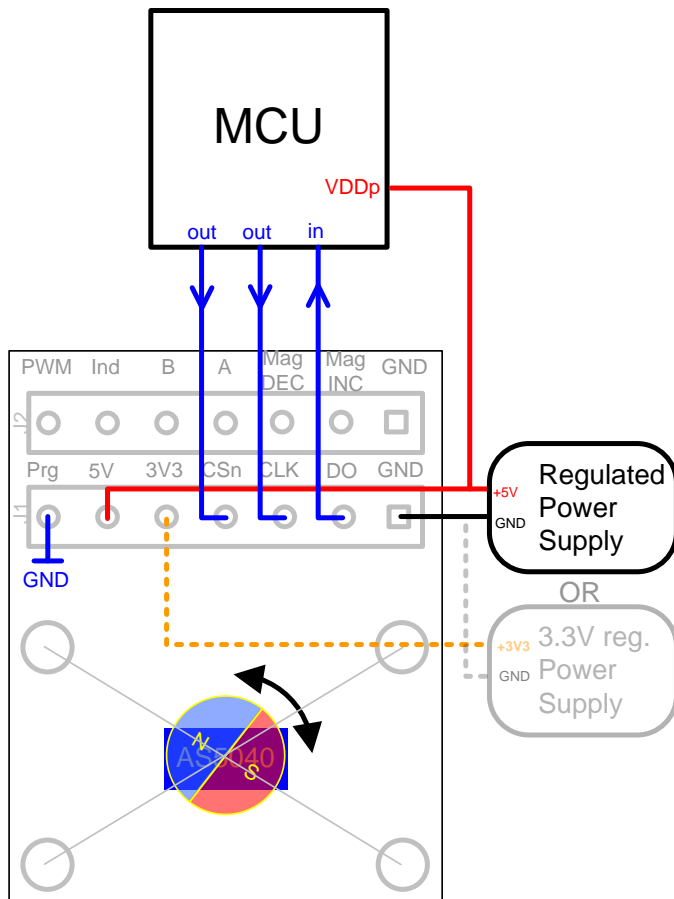

4.2 Standalone PWM output mode

The AS5040 provides a pulse width modulated output (PWM), whose duty cycle is proportional to the measured angle. The PWM signal (J2 pin #7) with a period of 1025us (1us step) and 5V pulse voltage can be connected to the capture/timer input of a microcontroller in order to decode the angle value.

Figure 6:
Using the PWM output with the adapter board

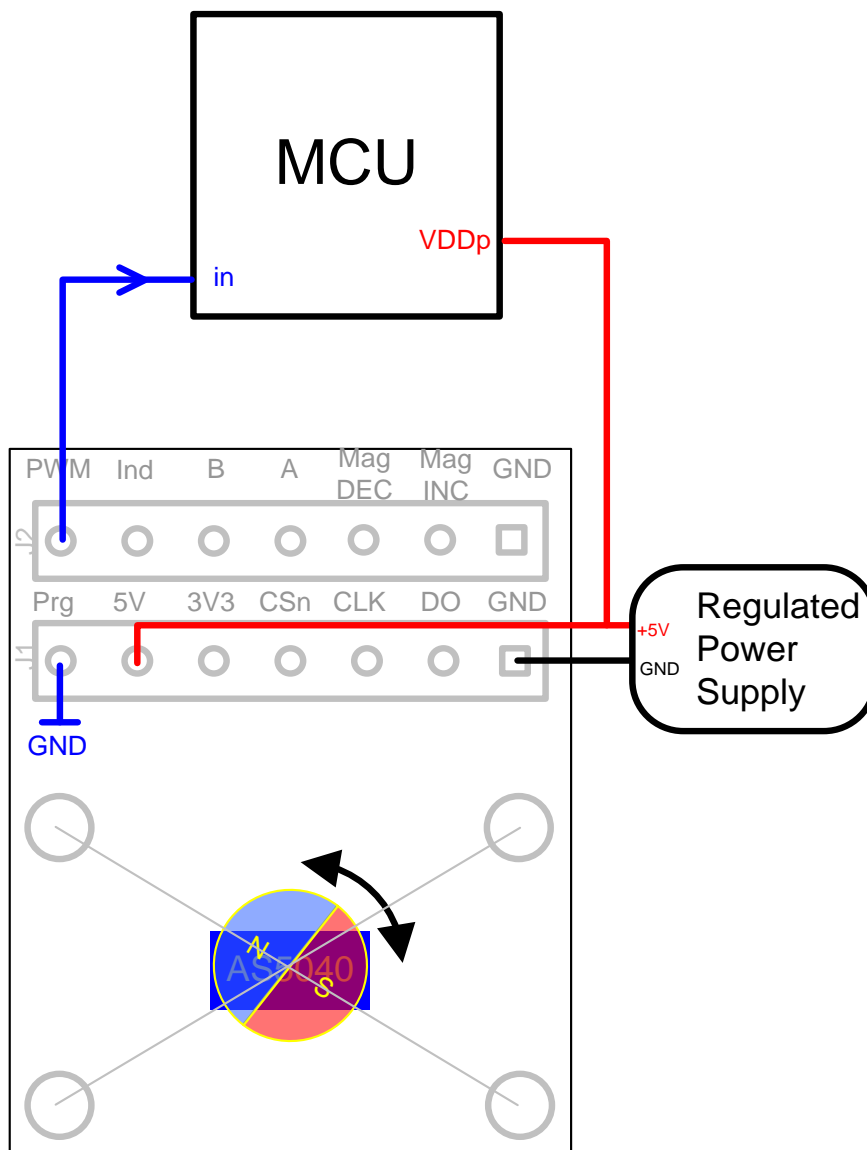
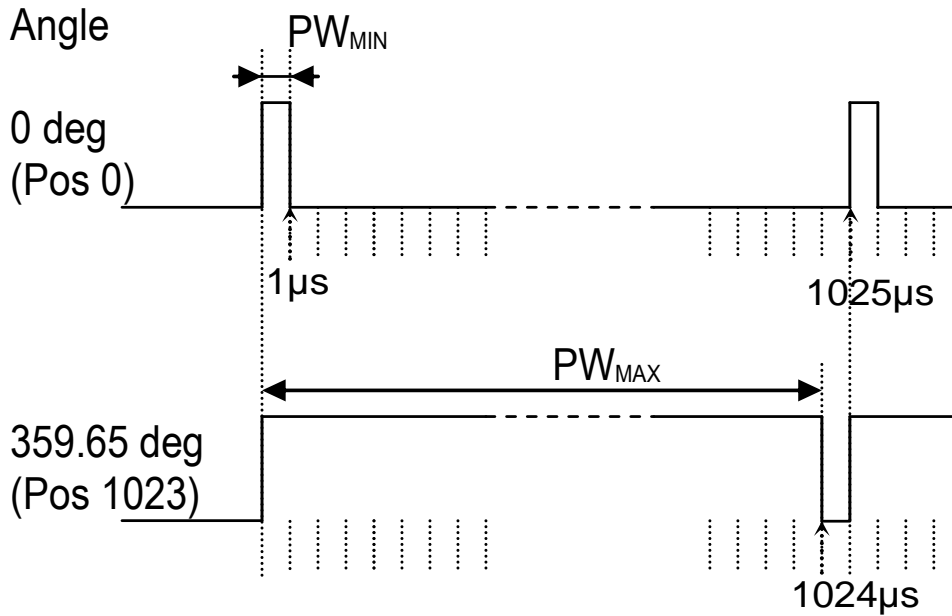



Figure 7:
PWM duty cycle depending on magnet position



4.3 Standalone incremental Output

Three different incremental output modes are possible with quadrature A/B being the default mode (two-channel quadrature, step / direction incremental signal (LSB) and the direction bit in clockwise (CW) and counter-clockwise (CCW) direction).

The pre-programmed version AS5145-I10 provides a 10bit and AS5145-I12 a 12bit incremental output.

The AS5045 doesn't provide an incremental output.

For further information, please refer to the datasheet.

Figure 8:
Using the Incremental output with the adapter board

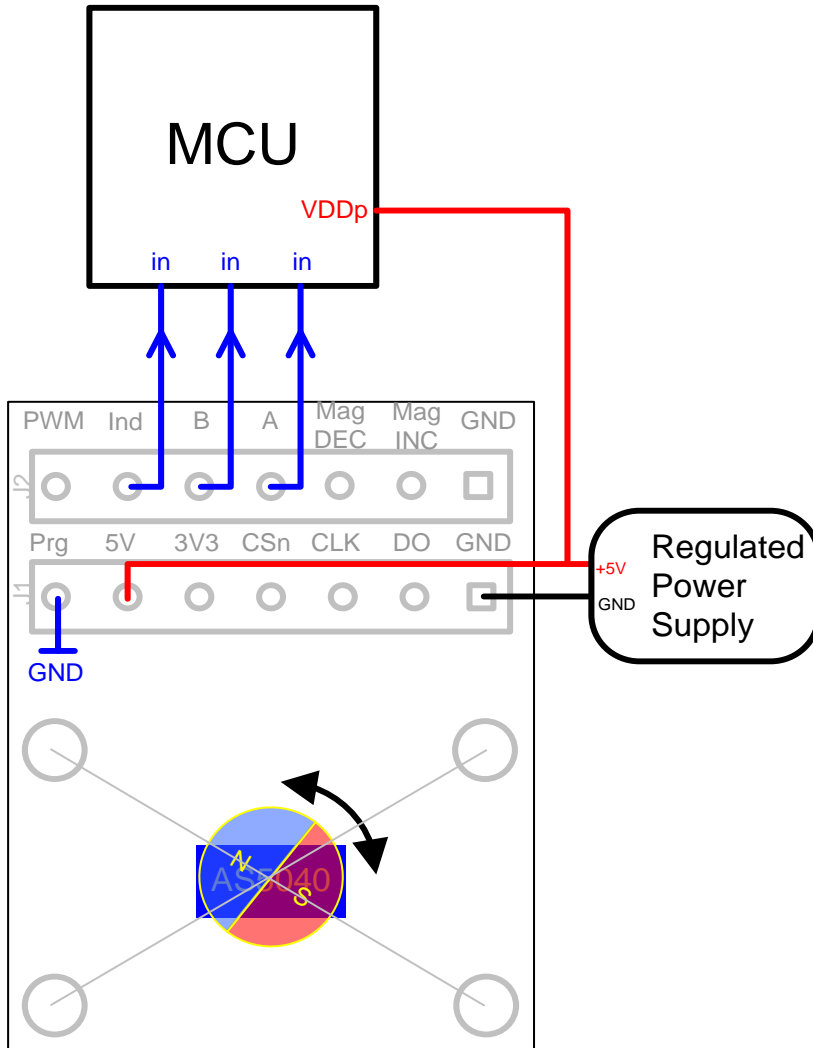



4.4 Daisy chain mode

By using more than one adapter board, a setup in daisy chain mode is possible.

Note: In this mode capacitor C3 (refer to Fig.12) must be disconnected when using the 1nF capacitor shown in Fig.9 or directly replaced by this capacitor.

The serial data of all connected devices is read from the DO pin of the first device in the chain. The Prog pin of the last device in the chain should be connected to VSS. The length of the serial bit stream increases with every connected device (board) by $n * (16+1)$ bits.

Due to $R = 100R$ and $C = 1nF$, the CLK is limited the maximum 1MHz.

Figure 9:
Using Daisy-Chain mode with the adapter board

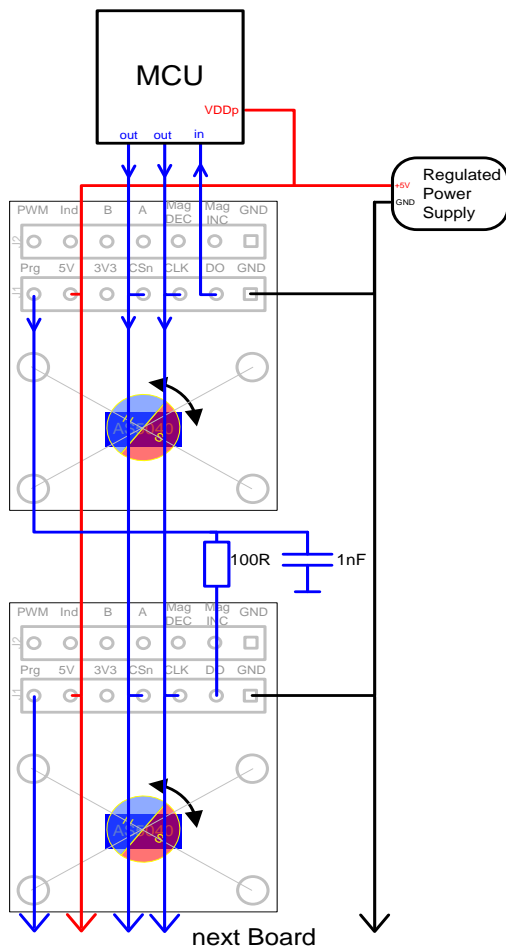



5 Programming the AS5040

After power-on, programming the AS5040 is enabled with the rising edge of CSn with Prog = high and CLK = low. 16 bit configuration data must be serially shifted into the OTP register via the Prog-pin. The first “CCW” bit is followed by the zero position data (MSB first / 10 bit for AS5x40 and 12 bit for AS5x45) and some mode settings (please refer to datasheet). Data must be valid at the rising edge of CLK.

After writing data into the OTP register it can be permanently programmed by rising the Prog pin to the programming voltage V_{PROG} of 7.3-7.5V. 16 CLK pulses must be applied to program the fuses.

For exiting the programming mode, the chip must be reset by a power-on-reset. The programmed data is available after the next power-up.

Figure 10:
Programming the AS5040

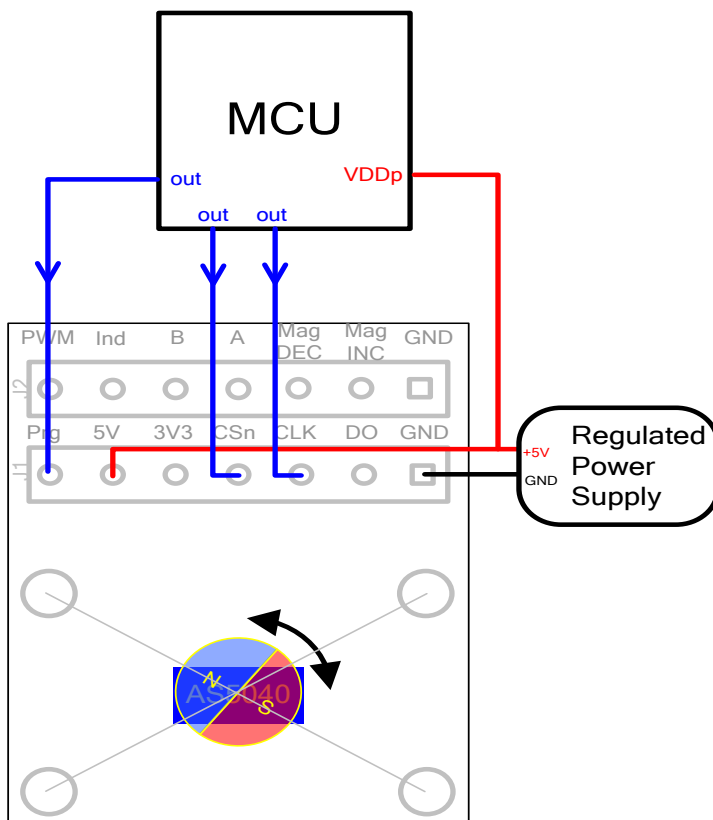

6 AS5040 differences to AS5045

The Table below shows the differences between AS5040 and AS5045

Table 2:
Differences AS5040/ AS5045

Building Block	AS5045	AS5040
Resolution	12bits, 0.088°/step.	10bit, 0.35°/step
Data length	read: 18bits (12bits data + 6 bits status) OTP write: 18 bits (12bits zero position + 6 bits mode selection)	read: 16bits (10bits data + 6 bits status) OTP write: 16 bits (10bits zero position + 6 bits mode selection)
incremental encoder	Not used Pin 3: not used Pin 4: not used	quadrature, step/direction and BLDC motor commutation modes Pin 3: incremental output A_LSB_U Pin 4: incremental output B_DIR_V
Pins 1 and 2	MagINCn, MagDECn: same feature as AS5040, additional OTP option for red-yellow-green magnetic range	MagINCn, MagDECn indicate in-range or out-of-range magnetic field plus movement of magnet in z-axis
Pin 6	MODE pin, switch between fast and slow mode	Pin 6: Index output
Pin 12	PWM output: frequency selectable by OTP: 1µs / step, 4096 steps per revolution, f=244Hz 2µs / step, 4096 steps per revolution, f=122Hz	PWM output: 1µs / step, 1024 steps per revolution, 976Hz PWM frequency
sampling frequency	selectable by MODE input pin: 2.5kHz, 10kHz	fixed at 10kHz @10bit resolution
Propagation delay	384µs (slow mode) 96µs (fast mode)	48µs
Transition noise (rms; 1sigma)	0.03 degrees max. (slow mode) 0.06 degrees max. (fast mode)	0.12 degrees
OTP programming options	zero position, rotational direction, PWM disable, 2 Magnetic Field indicator modes, 2 PWM frequencies	zero position, rotational direction, incremental modes, index bit width

7 AS5040 AB-Hardware

Below the schematic and layout can be found.

7.1 AS5040-AB-2.1 schematics

Figure 11:
AS5040-AB-2.1-Schematics

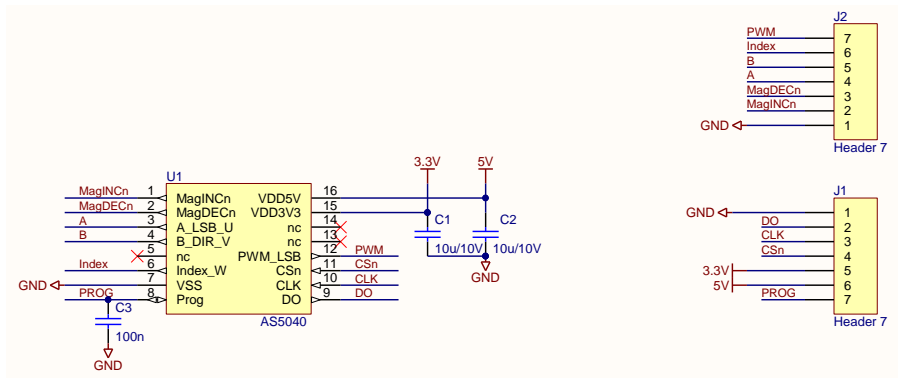

7.2 AS5040 – AB – 2.1 PCB layout

Figure 12:
AS5040-AB-2.1-Layout

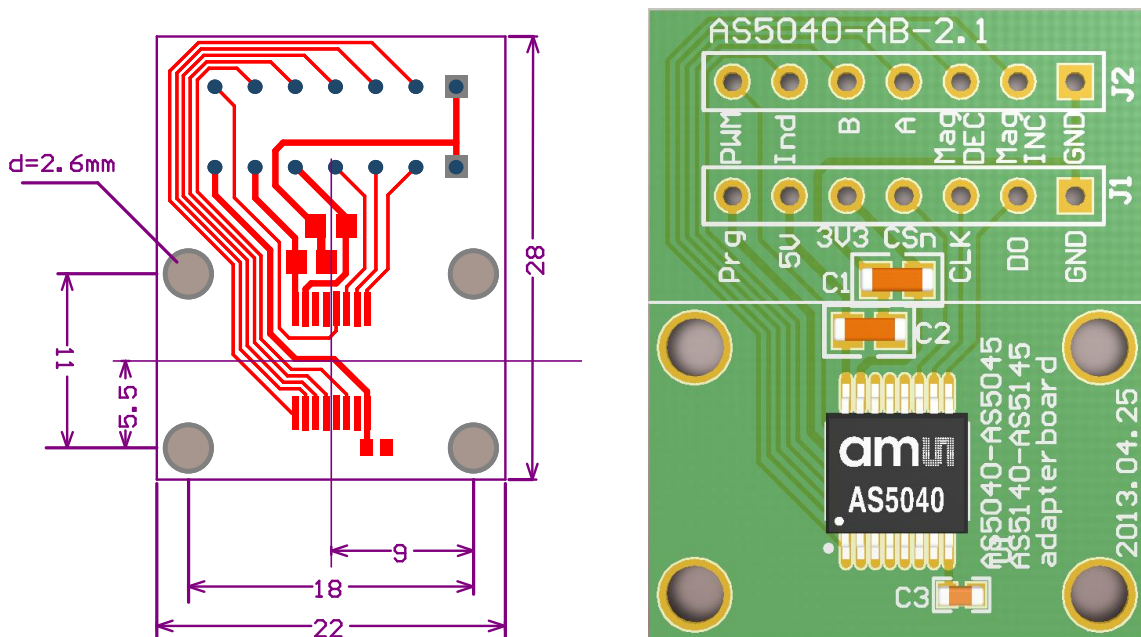

8 Copyright

Copyright ams AG, Tobelbader Strasse 30, 8141 Unterpremstätten, Austria-Europe. Trademarks Registered. All rights reserved. The material herein may not be reproduced, adapted, merged, translated, stored, or used without the prior written consent of the copyright owner.

9 Disclaimer

Devices sold by ams AG are covered by the warranty and patent indemnification provisions appearing in its Term of Sale. ams AG makes no warranty, express, statutory, implied, or by description regarding the information set forth herein. ams AG reserves the right to change specifications and prices at any time and without notice. Therefore, prior to designing this product into a system, it is necessary to check with ams AG for current information. This product is intended for use in commercial applications. Applications requiring extended temperature range, unusual environmental requirements, or high reliability applications, such as military, medical life-support or life-sustaining equipment are specifically not recommended without additional processing by ams AG for each application. This Product is provided by ams “AS IS” and any express or implied warranties, including, but not limited to the implied warranties of merchantability and fitness for a particular purpose are disclaimed.

ams AG shall not be liable to recipient or any third party for any damages, including but not limited to personal injury, property damage, loss of profits, loss of use, interruption of business or indirect, special, incidental or consequential damages, of any kind, in connection with or arising out of the furnishing, performance or use of the technical data herein. No obligation or liability to recipient or any third party shall arise or flow out of ams AG rendering of technical or other services.

10 Contact Information

Headquarters

ams AG

Tobelbader Strasse 30
8141 Unterpremstaetten

Austria

T. +43 (0) 3136 500 0

For Sales Offices, Distributors and Representatives, please visit:

<http://www.ams.com/contact>

Данный компонент на территории Российской Федерации

Вы можете приобрести в компании MosChip.

Для оперативного оформления запроса Вам необходимо перейти по данной ссылке:

<http://moschip.ru/get-element>

Вы можете разместить у нас заказ для любого Вашего проекта, будь то серийное производство или разработка единичного прибора.

В нашем ассортименте представлены ведущие мировые производители активных и пассивных электронных компонентов.

Нашей специализацией является поставка электронной компонентной базы двойного назначения, продукции таких производителей как XILINX, Intel (ex.ALTERA), Vicor, Microchip, Texas Instruments, Analog Devices, Mini-Circuits, Amphenol, Glenair.

Сотрудничество с глобальными дистрибьюторами электронных компонентов, предоставляет возможность заказывать и получать с международных складов практически любой перечень компонентов в оптимальные для Вас сроки.

На всех этапах разработки и производства наши партнеры могут получить квалифицированную поддержку опытных инженеров.

Система менеджмента качества компании отвечает требованиям в соответствии с ГОСТ Р ИСО 9001, ГОСТ РВ 0015-002 и ЭС РД 009

Офис по работе с юридическими лицами:

105318, г.Москва, ул.Щербаковская д.3, офис 1107, 1118, ДЦ «Щербаковский»

Телефон: +7 495 668-12-70 (многоканальный)

Факс: +7 495 668-12-70 (доб.304)

E-mail: info@moschip.ru

Skype отдела продаж:

moschip.ru

moschip.ru_4

moschip.ru_6

moschip.ru_9