



256K x 72, 512K x 36, 1024K x 18 18Mb SYNCHRONOUS FLOW-THROUGH STATIC RAM

JULY 2010

FEATURES

- Internal self-timed write cycle
- Individual Byte Write Control and Global Write
- Clock controlled, registered address, data and control
- Burst sequence control using MODE input
- Three chip enable option for simple depth expansion and address pipelining
- Common data inputs and data outputs
- Auto Power-down during deselect
- Single cycle deselect
- Snooze MODE for reduced-power standby
- JTAG Boundary Scan for PBGA package
- Power Supply
 LF: $V_{DD} 3.3V \pm 5\%$, $V_{DDQ} 3.3V/2.5V \pm 5\%$
 VF: $V_{DD} 2.5V \pm 5\%$, $V_{DDQ} 2.5V \pm 5\%$
- JEDEC 100-Pin TQFP, 119-pin PBGA, 209-Ball PBGA and 165-pin PBGA packages.
- Lead-free available

DESCRIPTION

The *ISSI* IS61LF/VF25672A, IS61LF/VF51236A and IS61LF/VF102418A are high-speed, low-power synchronous static RAMs designed to provide burstable, high-performance memory for communication and networking applications. The IS61LF/VF25672A is organized as 262,144 words by 72 bits. The IS61LF/VF51236A is organized as 524,288 words by 36 bits. The IS61LF/VF102418A is organized as 1,048,576 words by 18 bits. Fabricated with *ISSI*'s advanced CMOS technology, the device integrates a 2-bit burst counter, high-speed SRAM core, and high-drive capability outputs into a single monolithic circuit. All synchronous inputs pass through registers controlled by a positive-edge-triggered single clock input.

Write cycles are internally self-timed and are initiated by the rising edge of the clock input. Write cycles can be one to four bytes wide as controlled by the write control inputs.

Separate byte enables allow individual bytes to be written. Byte write operation is performed by using byte write enable (\overline{BWE}) input combined with one or more individual byte write signals (\overline{BWx}). In addition, Global Write (\overline{GW}) is available for writing all bytes at one time, regardless of the byte write controls.

Bursts can be initiated with either \overline{ADSP} (Address Status Processor) or \overline{ADSC} (Address Status Cache Controller) input pins. Subsequent burst addresses can be generated internally and controlled by the \overline{ADV} (burst address advance) input pin.

The mode pin is used to select the burst sequence order, Linear burst is achieved when this pin is tied LOW. Interleave burst is achieved when this pin is tied HIGH or left floating.

FAST ACCESS TIME

| Symbol | Parameter | -6.5 | -7.5 | Units |
|--------|-------------------|------|------|-------|
| tkQ | Clock Access Time | 6.5 | 7.5 | ns |
| tkc | Cycle Time | 7.5 | 8.5 | ns |
| | Frequency | 133 | 117 | MHz |

Copyright © 2010 Integrated Silicon Solution, Inc. All rights reserved. ISSI reserves the right to make changes to this specification and its products at any time without notice. ISSI assumes no liability arising out of the application or use of any information, products or services described herein. Customers are advised to obtain the latest version of this device specification before relying on any published information and before placing orders for products.

Integrated Silicon Solution, Inc. does not recommend the use of any of its products in life support applications where the failure or malfunction of the product can reasonably be expected to cause failure of the life support system or to significantly affect its safety or effectiveness. Products are not authorized for use in such applications unless Integrated Silicon Solution, Inc. receives written assurance to its satisfaction, that:

- the risk of injury or damage has been minimized;
- the user assume all such risks; and
- potential liability of Integrated Silicon Solution, Inc is adequately protected under the circumstances

BLOCK DIAGRAM



165-PIN BGA

165-Ball, 13x15 mm BGA

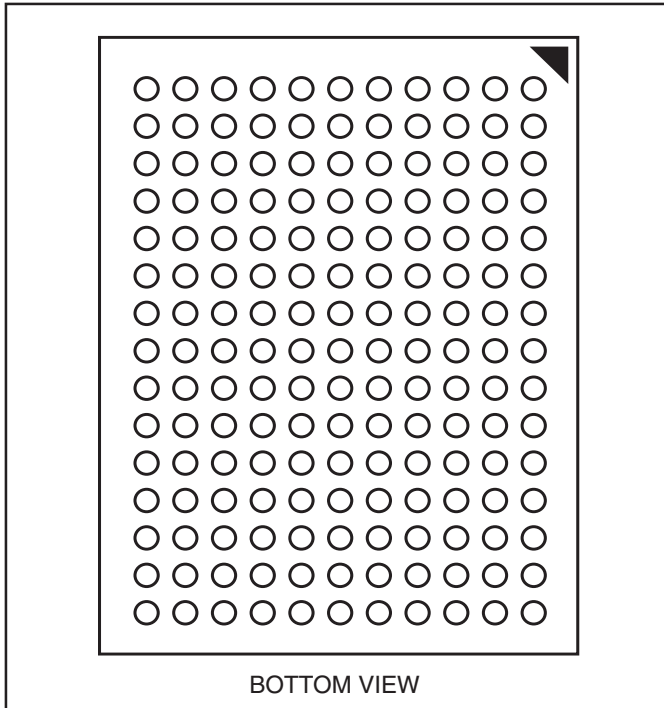

119-PIN BGA

119-Ball, 14x22 mm BGA

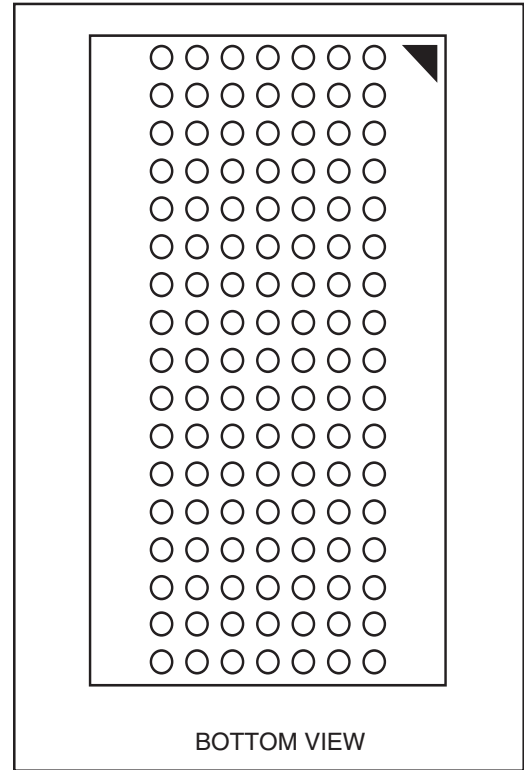

209-BALL BGA

209-Ball, 14 mm x 22 mm BGA
1 mm Ball Pitch, 11 x 19 Ball Array

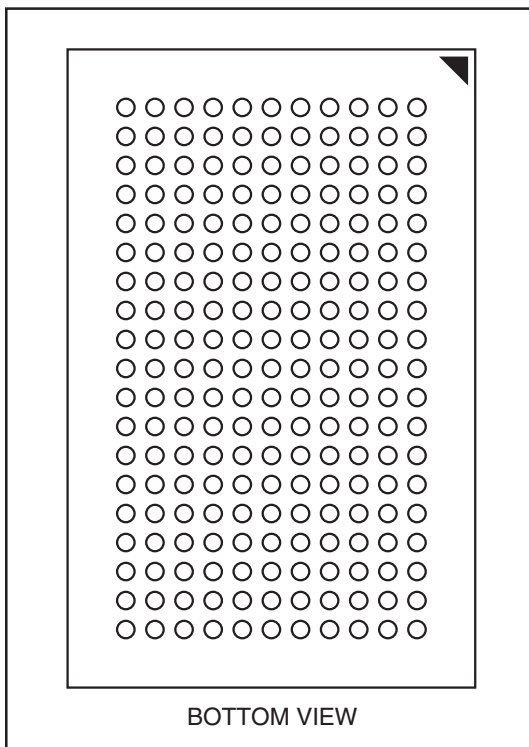

PIN CONFIGURATION — 256K X 72, 209-Ball PBGA (TOP VIEW)

| | 1 | 2 | 3 | 4 | 5 | 6 | 7 | 8 | 9 | 10 | 11 |
|---|------|------|-------------------------|-------------------------|--------------------------|--------------------------|-------------------------|-------------------------|-------------------------|------|------|
| A | DQg | DQg | A | CE2 | $\overline{\text{ADSP}}$ | $\overline{\text{ADSC}}$ | $\overline{\text{ADV}}$ | $\overline{\text{CE2}}$ | A | DQb | DQb |
| B | DQg | DQg | $\overline{\text{BWc}}$ | $\overline{\text{BWg}}$ | NC | $\overline{\text{BWE}}$ | A | $\overline{\text{BWb}}$ | $\overline{\text{BWf}}$ | DQb | DQb |
| C | DQg | DQg | $\overline{\text{BWh}}$ | $\overline{\text{BWd}}$ | NC | $\overline{\text{CE}}$ | NC | $\overline{\text{BWe}}$ | $\overline{\text{BWa}}$ | DQb | DQb |
| D | DQg | DQg | VSS | NC | NC | $\overline{\text{OE}}$ | $\overline{\text{GW}}$ | NC | VSS | DQb | DQb |
| E | DQPg | DQPC | VDDQ | VDDQ | VDD | VDD | VDD | VDDQ | VDDQ | DQPf | DQPb |
| F | DQc | DQc | VSS | VSS | VSS | NC | VSS | VSS | VSS | DQf | DQf |
| G | DQc | DQc | VDDQ | VDDQ | VDD | NC | VDD | VDDQ | VDDQ | DQf | DQf |
| H | DQc | DQc | VSS | VSS | VSS | NC | VSS | VSS | VSS | DQf | DQf |
| J | DQc | DQc | VDDQ | VDDQ | VDD | NC | VDD | VDDQ | VDDQ | DQf | DQf |
| K | NC | NC | CLK | NC | VSS | NC | VSS | NC | NC | NC | NC |
| L | DQh | DQh | VDDQ | VDDQ | VDD | NC | VDD | VDDQ | VDDQ | DQa | DQa |
| M | DQh | DQh | VSS | VSS | VSS | NC | VSS | VSS | VSS | DQa | DQa |
| N | DQh | DQh | VDDQ | VDDQ | VDD | NC | VDD | VDDQ | VDDQ | DQa | DQa |
| P | DQh | DQh | VSS | VSS | VSS | ZZ | VSS | VSS | VSS | DQa | DQa |
| R | DQPd | DQPh | VDDQ | VDDQ | VDD | VDD | VDD | VDDQ | VDDQ | DQPa | DQPe |
| T | DQd | DQd | VSS | NC | NC | MODE | NC | NC | VSS | DQe | DQe |
| U | DQd | DQd | NC | A | A | A | A | A | NC | DQe | DQe |
| V | DQd | DQd | A | A | A | A1 | A | A | A | DQe | DQe |
| W | DQd | DQd | TMS | TDI | A | A0 | A | TDO | TCK | DQe | DQe |

11 x 19 Ball BGA—14 x 22 mm² Body—1 mm Ball Pitch

PIN DESCRIPTIONS

| Symbol | Pin Name |
|--|-----------------------------------|
| A | Address Inputs |
| A0, A1 | Synchronous Burst Address Inputs |
| $\overline{\text{ADV}}$ | Synchronous Burst Address Advance |
| $\overline{\text{ADSP}}$ | Address Status Processor |
| $\overline{\text{ADSC}}$ | Address Status Controller |
| $\overline{\text{GW}}$ | Global Write Enable |
| CLK | Synchronous Clock |
| $\overline{\text{CE}}$, $\overline{\text{CE2}}$, CE2 | Synchronous Chip Select |
| $\overline{\text{BWx}}$ (x=a,b,c,d e,f,g,h) | Synchronous Byte Write Controls |

| Symbol | Pin Name |
|-------------------------|---|
| $\overline{\text{BWE}}$ | Byte Write Enable |
| $\overline{\text{OE}}$ | Output Enable |
| ZZ | Power Sleep Mode |
| MODE | Burst Sequence Selection |
| TCK, TDO TMS, TDI | JTAG Pins |
| NC | No Connect |
| DQx | Data Inputs/Outputs |
| DQPx | Data Inputs/Outputs |
| VDD | 3.3V/2.5V Power Supply |
| VDDQ | Isolated Output Power Supply 3.3V/2.5V |
| Vss | Ground |

119 BGA PACKAGE PIN CONFIGURATION-512K x 36 (TOP VIEW)

| | 1 | 2 | 3 | 4 | 5 | 6 | 7 |
|----------|------------------|-----------------|--------------------------|--------------------------|--------------------------|-----------------|------------------|
| A | V _{DDQ} | A | A | $\overline{\text{ADSP}}$ | A | A | V _{DDQ} |
| B | NC | A | A | $\overline{\text{ADSC}}$ | A | A | NC |
| C | NC | A | A | V _{DD} | A | A | NC |
| D | DQc | DQPc | V _{SS} | NC | V _{SS} | DQPb | DQb |
| E | DQc | DQc | V _{SS} | $\overline{\text{CE}}$ | V _{SS} | DQb | DQb |
| F | V _{DDQ} | DQc | V _{SS} | $\overline{\text{OE}}$ | V _{SS} | DQb | V _{DDQ} |
| G | DQc | DQc | $\overline{\text{Bw}}_c$ | $\overline{\text{ADV}}$ | $\overline{\text{Bw}}_b$ | DQb | DQb |
| H | DQc | DQc | V _{SS} | $\overline{\text{GW}}$ | V _{SS} | DQb | DQb |
| J | V _{DDQ} | V _{DD} | NC | V _{DD} | NC | V _{DD} | V _{DDQ} |
| K | DQd | DQd | V _{SS} | CLK | V _{SS} | DQa | DQa |
| L | DQd | DQd | $\overline{\text{Bw}}_d$ | NC | $\overline{\text{Bw}}_a$ | DQa | DQa |
| M | V _{DDQ} | DQd | V _{SS} | $\overline{\text{BWE}}$ | V _{SS} | DQa | V _{DDQ} |
| N | DQd | DQd | V _{SS} | A ₁ * | V _{SS} | DQa | DQa |
| P | DQd | DQPd | V _{SS} | A ₀ * | V _{SS} | DQPd | DQa |
| R | NC | A | MODE | V _{DD} | NC | A | NC |
| T | NC | NC | A | A | A | NC | ZZ |
| U | V _{DDQ} | TMS | TDI | TCK | TDO | NC | V _{DDQ} |

Note: * A₀ and A₁ are the two least significant bits (LSB) of the address field and set the internal burst counter if burst is desired.

PIN DESCRIPTIONS

| Symbol | Pin Name |
|----------------------------------|------------------------------------|
| A | Address Inputs |
| A0, A1 | Synchronous Burst Address Inputs |
| $\overline{\text{ADV}}$ | Synchronous Burst Address Advance. |
| $\overline{\text{ADSP}}$ | Address Status Processor |
| $\overline{\text{ADSC}}$ | Address Status Controller |
| $\overline{\text{GW}}$ | Global Write Enable |
| CLK | Synchronous Clock |
| $\overline{\text{CE}}$ | Synchronous Chip Select |
| $\overline{\text{Bw}}_x$ (x=a-d) | Synchronous Byte Write Controls |
| $\overline{\text{BWE}}$ | Byte Write Enable |

| Symbol | Pin Name |
|------------------------|--------------------------|
| $\overline{\text{OE}}$ | Output Enable |
| ZZ | Power Sleep Mode |
| MODE | Burst Sequence Selection |
| TCK, TDO | JTAG Pins |
| TMS, TDI | |
| NC | No Connect |
| DQa-DQd | Data Inputs/Outputs |
| DQPd-Pd | Data Inputs/Outputs |
| V _{DD} | Power Supply |
| V _{DDQ} | Output Power Supply |
| V _{SS} | Ground |

119 BGA PACKAGE PIN CONFIGURATION

1Mx18 (TOP VIEW)

| | 1 | 2 | 3 | 4 | 5 | 6 | 7 |
|----------|------------------|------------------|-------------------------|--------------------------|-------------------------|------------------|------------------|
| A | V _{DDQ} | A | A | $\overline{\text{ADSP}}$ | A | A | V _{DDQ} |
| B | NC | A | A | $\overline{\text{ADSC}}$ | A | A | NC |
| C | NC | A | A | V _{DD} | A | A | NC |
| D | DQ _b | NC | V _{SS} | NC | V _{SS} | DQP _a | NC |
| E | NC | DQ _b | V _{SS} | $\overline{\text{CE}}$ | V _{SS} | NC | DQ _a |
| F | V _{DDQ} | NC | V _{SS} | $\overline{\text{OE}}$ | V _{SS} | DQ _a | V _{DDQ} |
| G | NC | DQ _b | $\overline{\text{BWb}}$ | $\overline{\text{ADV}}$ | V _{SS} | NC | DQ _a |
| H | DQ _b | NC | V _{SS} | $\overline{\text{GW}}$ | V _{SS} | DQ _a | NC |
| J | V _{DDQ} | V _{DD} | NC | V _{DD} | NC | V _{DD} | V _{DDQ} |
| K | NC | DQ _b | V _{SS} | CLK | V _{SS} | NC | DQ _a |
| L | DQ _b | NC | V _{SS} | NC | $\overline{\text{BWa}}$ | DQ _a | NC |
| M | V _{DDQ} | DQ _b | V _{SS} | $\overline{\text{BWE}}$ | V _{SS} | NC | V _{DDQ} |
| N | DQ _b | NC | V _{SS} | A ₁ * | V _{SS} | DQ _a | NC |
| P | NC | DQP _b | V _{SS} | A ₀ * | V _{SS} | NC | DQ _a |
| R | NC | A | MODE | V _{DD} | NC | A | NC |
| T | NC | A | A | NC | A | A | ZZ |
| U | V _{DDQ} | TMS | TDI | TCK | TDO | NC | V _{DDQ} |

Note: * A₀ and A₁ are the two least significant bits (LSB) of the address field and set the internal burst counter if burst is desired.

PIN DESCRIPTIONS

| Symbol | Pin Name |
|----------------------------------|------------------------------------|
| A | Address Inputs |
| A0, A1 | Synchronous Burst Address Inputs |
| $\overline{\text{ADV}}$ | Synchronous Burst Address Advance. |
| $\overline{\text{ADSP}}$ | Address Status Processor |
| $\overline{\text{ADSC}}$ | Address Status Controller |
| $\overline{\text{GW}}$ | Global Write Enable |
| CLK | Synchronous Clock |
| $\overline{\text{CE}}$ | Synchronous Chip Select |
| $\overline{\text{BW}}_x$ (x=a,b) | Synchronous Byte Write Controls |
| $\overline{\text{BWE}}$ | Byte Write Enable |

| Symbol | Pin Name |
|----------------------------------|--------------------------|
| $\overline{\text{OE}}$ | Output Enable |
| ZZ | Power Sleep Mode |
| MODE | Burst Sequence Selection |
| TCK, TDO TMS, TDI | JTAG Pins |
| NC | No Connect |
| DQ _a -DQ _b | Data Inputs/Outputs |
| DQP _a -P _b | Data Inputs/Outputs |
| V _{DD} | Power Supply |
| V _{DDQ} | Output Power Supply |
| V _{SS} | Ground |

165 PBGA PACKAGE PIN CONFIGURATION

512K x 36 (TOP VIEW)

| | 1 | 2 | 3 | 4 | 5 | 6 | 7 | 8 | 9 | 10 | 11 |
|----------|------|-----------------|------------------|------------------|------------------|------------------|------------------|-------------------|-------------------|-----|------|
| A | NC | A | \overline{CE} | \overline{BWc} | \overline{BWb} | $\overline{CE2}$ | \overline{BWE} | \overline{ADSC} | \overline{ADV} | A | NC |
| B | NC | A | CE2 | \overline{BWd} | \overline{BWa} | CLK | \overline{GW} | \overline{OE} | \overline{ADSP} | A | NC |
| C | DQPc | NC | V _{DDQ} | V _{SS} | V _{SS} | V _{SS} | V _{SS} | V _{SS} | V _{DDQ} | NC | DQPb |
| D | DQc | DQc | V _{DDQ} | V _{DD} | V _{SS} | V _{SS} | V _{SS} | V _{DD} | V _{DDQ} | DQb | DQb |
| E | DQc | DQc | V _{DDQ} | V _{DD} | V _{SS} | V _{SS} | V _{SS} | V _{DD} | V _{DDQ} | DQb | DQb |
| F | DQc | DQc | V _{DDQ} | V _{DD} | V _{SS} | V _{SS} | V _{SS} | V _{DD} | V _{DDQ} | DQb | DQb |
| G | DQc | DQc | V _{DDQ} | V _{DD} | V _{SS} | V _{SS} | V _{SS} | V _{DD} | V _{DDQ} | DQb | DQb |
| H | NC | V _{SS} | NC | V _{DD} | V _{SS} | V _{SS} | V _{SS} | V _{DD} | NC | NC | ZZ |
| J | DQd | DQd | V _{DDQ} | V _{DD} | V _{SS} | V _{SS} | V _{SS} | V _{DD} | V _{DDQ} | DQa | DQa |
| K | DQd | DQd | V _{DDQ} | V _{DD} | V _{SS} | V _{SS} | V _{SS} | V _{DD} | V _{DDQ} | DQa | DQa |
| L | DQd | DQd | V _{DDQ} | V _{DD} | V _{SS} | V _{SS} | V _{SS} | V _{DD} | V _{DDQ} | DQa | DQa |
| M | DQd | DQd | V _{DDQ} | V _{DD} | V _{SS} | V _{SS} | V _{SS} | V _{DD} | V _{DDQ} | DQa | DQa |
| N | DQPd | NC | V _{DDQ} | V _{SS} | NC | A | V _{SS} | V _{SS} | V _{DDQ} | NC | DQPd |
| P | NC | NC | A | A | TDI | A1* | TDO | A | A | A | A |
| R | MODE | NC | A | A | TMS | A0* | TCK | A | A | A | A |

Note: * A0 and A1 are the two least significant bits (LSB) of the address field and set the internal burst counter if burst is desired.

PIN DESCRIPTIONS

| Symbol | Pin Name |
|--|------------------------------------|
| A | Address Inputs |
| A0, A1 | Synchronous Burst Address Inputs |
| \overline{ADV} | Synchronous Burst Address Advance. |
| \overline{ADSP} | Address Status Processor |
| \overline{ADSC} | Address Status Controller |
| \overline{GW} | Global Write Enable |
| CLK | Synchronous Clock |
| \overline{CE} , $\overline{CE2}$, CE2 | Synchronous Chip Select |
| \overline{BWx} (x=a,b,c,d) | Synchronous Byte Write Controls |

| Symbol | Pin Name |
|----------------------|--------------------------|
| \overline{BWE} | Byte Write Enable |
| \overline{OE} | Output Enable |
| ZZ | Power Sleep Mode |
| MODE | Burst Sequence Selection |
| TCK, TDO TMS, TDI | JTAG Pins |
| NC | No Connect |
| DQa-DQd | Data Inputs/Outputs |
| DQPd-Pd | Data Inputs/Outputs |
| V _{DD} | Power Supply |
| V _{DDQ} | Output Power Supply |
| V _{SS} | Ground |

165 PBGA PACKAGE PIN CONFIGURATION

1M x 18 (TOP VIEW)

| | 1 | 2 | 3 | 4 | 5 | 6 | 7 | 8 | 9 | 10 | 11 |
|----------|------------------|-----------------|-----------------|------------------|------------------|------------------|------------------|-------------------|-------------------|-----------------|------------------|
| A | NC | A | \overline{CE} | \overline{BWB} | NC | $\overline{CE2}$ | \overline{BWE} | \overline{ADSC} | \overline{ADV} | A | A |
| B | NC | A | CE2 | NC | \overline{BWA} | CLK | \overline{GW} | \overline{OE} | \overline{ADSP} | A | NC |
| C | NC | NC | VDDQ | VSS | VSS | VSS | VSS | VSS | VDDQ | NC | DQP _a |
| D | NC | DQ _b | VDDQ | VDD | VSS | VSS | VSS | VDD | VDDQ | NC | DQ _a |
| E | NC | DQ _b | VDDQ | VDD | VSS | VSS | VSS | VDD | VDDQ | NC | DQ _a |
| F | NC | DQ _b | VDDQ | VDD | VSS | VSS | VSS | VDD | VDDQ | NC | DQ _a |
| G | NC | DQ _b | VDDQ | VDD | VSS | VSS | VSS | VDD | VDDQ | NC | DQ _a |
| H | NC | VSS | NC | VDD | VSS | VSS | VSS | VDD | NC | NC | ZZ |
| J | DQ _b | NC | VDDQ | VDD | VSS | VSS | VSS | VDD | VDDQ | DQ _a | NC |
| K | DQ _b | NC | VDDQ | VDD | VSS | VSS | VSS | VDD | VDDQ | DQ _a | NC |
| L | DQ _b | NC | VDDQ | VDD | VSS | VSS | VSS | VDD | VDDQ | DQ _a | NC |
| M | DQ _b | NC | VDDQ | VDD | VSS | VSS | VSS | VDD | VDDQ | DQ _a | NC |
| N | DQP _b | NC | VDDQ | VSS | NC | A | VSS | VSS | VDDQ | NC | NC |
| P | NC | NC | A | A | TDI | A1* | TDO | A | A | A | A |
| R | MODE | NC | A | A | TMS | A0* | TCK | A | A | A | A |

Note: * A₀ and A₁ are the two least significant bits (LSB) of the address field and set the internal burst counter if burst is desired.

PIN DESCRIPTIONS

| Symbol | Pin Name |
|--|------------------------------------|
| A | Address Inputs |
| A0, A1 | Synchronous Burst Address Inputs |
| \overline{ADV} | Synchronous Burst Address Advance. |
| \overline{ADSP} | Address Status Processor |
| \overline{ADSC} | Address Status Controller |
| \overline{GW} | Global Write Enable |
| CLK | Synchronous Clock |
| \overline{CE} , $\overline{CE2}$, CE2 | Synchronous Chip Select |
| \overline{BWx} (x=a,b) | Synchronous Byte Write Controls |

| Symbol | Pin Name |
|----------------------------------|--------------------------|
| \overline{BWE} | Byte Write Enable |
| \overline{OE} | Output Enable |
| ZZ | Power Sleep Mode |
| MODE | Burst Sequence Selection |
| TCK, TDO | JTAG Pins |
| TMS, TDI | JTAG Pins |
| NC | No Connect |
| DQ _a -DQ _d | Data Inputs/Outputs |
| DQP _a -Pd | Data Inputs/Outputs |
| VDD | Power Supply |
| VDDQ | Output Power Supply |
| VSS | Ground |

PIN CONFIGURATION

100-Pin TQFP

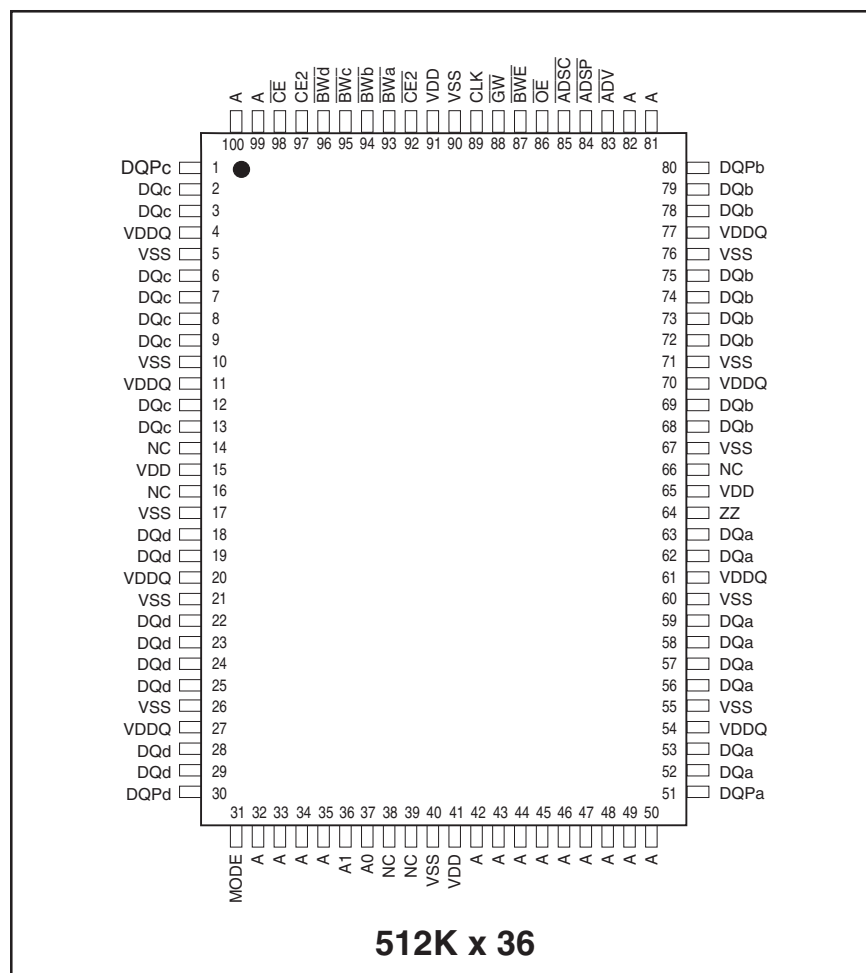

PIN DESCRIPTIONS

| | | | |
|---|--|------------------------|--|
| A0, A1 | Synchronous Address Inputs. These pins must tied to the two LSBs of the address bus. | DQPd-DQPd | Parity Data Input/Output |
| A | Synchronous Address Inputs | Vss | Ground |
| $\overline{\text{ADSC}}$ | Synchronous Controller Address Status | $\overline{\text{GW}}$ | Synchronous Global Write Enable |
| $\overline{\text{ADSP}}$ | Synchronous Processor Address Status | MODE | Burst Sequence Mode Selection |
| $\overline{\text{ADV}}$ | Synchronous Burst Address Advance | $\overline{\text{OE}}$ | Output Enable |
| $\overline{\text{BWA}}-\overline{\text{BWd}}$ | Synchronous Byte Write Enable | TMS, TDI, TCK, TDO | JTAG Boundary Scan Pins |
| $\overline{\text{BWE}}$ | Synchronous Byte Write Enable | VDD | 3.3V/2.5V Power Supply |
| $\overline{\text{CE}}$, CE2, $\overline{\text{CE2}}$ | Synchronous Chip Enable | VDDQ | Isolated Output Buffer Supply: 3.3V/2.5V |
| CLK | Synchronous Clock | ZZ | Snooze Enable |
| DQa-DQd | Synchronous Data Input/Output | | |

PIN CONFIGURATION

100-Pin TQFP



PIN DESCRIPTIONS

| | | | |
|--|--|------------------------|---|
| A0, A1 | Synchronous Address Inputs. These pins must tied to the two LSBs of the address bus. | DQPa-DQPa | Parity Data I/O; DQPa is parity for DQa1-8; DQPa is parity for DQb1-8 |
| A | Synchronous Address Inputs | Vss | Ground |
| $\overline{\text{ADSC}}$ | Synchronous Controller Address Status | $\overline{\text{GW}}$ | Synchronous Global Write Enable |
| $\overline{\text{ADSP}}$ | Synchronous Processor Address Status | MODE | Burst Sequence Mode Selection |
| $\overline{\text{ADV}}$ | Synchronous Burst Address Advance | $\overline{\text{OE}}$ | Output Enable |
| $\overline{\text{BWA}}-\overline{\text{BWB}}$ | Synchronous Byte Write Enable | TMS, TDI, TCK, TDO | JTAG Boundary Scan Pins |
| $\overline{\text{BWE}}$ | Synchronous Byte Write Enable | VDD | 3.3V/2.5V Power Supply |
| $\overline{\text{CE}}, \overline{\text{CE2}}, \overline{\text{CE2}}$ | Synchronous Chip Enable | VDDQ | Isolated Output Buffer Supply: 3.3V/2.5V |
| CLK | Synchronous Clock | ZZ | Snooze Enable |
| DQa-DQb | Synchronous Data Input/Output | | |

TRUTH TABLE⁽¹⁻⁸⁾ (3CE option)

| OPERATION | ADDRESS | \overline{CE} | $\overline{CE2}$ | CE2 | ZZ | \overline{ADSP} | \overline{ADSC} | \overline{ADV} | WRITE | \overline{OE} | CLK | DQ |
|-----------------------------|----------|-----------------|------------------|-----|----|-------------------|-------------------|------------------|-------|-----------------|-----|--------|
| Deselect Cycle, Power-Down | None | H | X | X | L | X | L | X | X | X | L-H | High-Z |
| Deselect Cycle, Power-Down | None | L | X | L | L | L | X | X | X | X | L-H | High-Z |
| Deselect Cycle, Power-Down | None | L | H | X | L | L | X | X | X | X | L-H | High-Z |
| Deselect Cycle, Power-Down | None | L | X | L | L | H | L | X | X | X | L-H | High-Z |
| Deselect Cycle, Power-Down | None | L | H | X | L | H | L | X | X | X | L-H | High-Z |
| Snooze Mode, Power-Down | None | X | X | X | H | X | X | X | X | X | X | High-Z |
| Read Cycle, Begin Burst | External | L | L | H | L | L | X | X | X | L | L-H | Q |
| Read Cycle, Begin Burst | External | L | L | H | L | L | X | X | X | H | L-H | High-Z |
| Write Cycle, Begin Burst | External | L | L | H | L | H | L | X | L | X | L-H | D |
| Read Cycle, Begin Burst | External | L | L | H | L | H | L | X | H | L | L-H | Q |
| Read Cycle, Begin Burst | External | L | L | H | L | H | L | X | H | H | L-H | High-Z |
| Read Cycle, Continue Burst | Next | X | X | X | L | H | H | L | H | L | L-H | Q |
| Read Cycle, Continue Burst | Next | X | X | X | L | H | H | L | H | H | L-H | High-Z |
| Read Cycle, Continue Burst | Next | H | X | X | L | X | H | L | H | L | L-H | Q |
| Read Cycle, Continue Burst | Next | H | X | X | L | X | H | L | H | H | L-H | High-Z |
| Write Cycle, Continue Burst | Next | X | X | X | L | H | H | L | L | X | L-H | D |
| Write Cycle, Continue Burst | Next | H | X | X | L | X | H | L | L | X | L-H | D |
| Read Cycle, Suspend Burst | Current | X | X | X | L | H | H | H | H | L | L-H | Q |
| Read Cycle, Suspend Burst | Current | X | X | X | L | H | H | H | H | H | L-H | High-Z |
| Read Cycle, Suspend Burst | Current | H | X | X | L | X | H | H | H | L | L-H | Q |
| Read Cycle, Suspend Burst | Current | H | X | X | L | X | H | H | H | H | L-H | High-Z |
| Write Cycle, Suspend Burst | Current | X | X | X | L | H | H | H | L | X | L-H | D |
| Write Cycle, Suspend Burst | Current | H | X | X | L | X | H | H | L | X | L-H | D |

NOTE:

1. X means "Don't Care." H means logic HIGH. L means logic LOW.
2. For **WRITE**, L means one or more byte write enable signals ($\overline{BWA-h}$) and \overline{BWE} are LOW or \overline{GW} is LOW. **WRITE** = H for all \overline{BWx} , \overline{BWE} , \overline{GW} HIGH.
3. \overline{BWA} enables WRITES to DQa's and DQPd. \overline{BWB} enables WRITES to DQb's and DQpb. \overline{BWC} enables WRITES to DQc's and DQpc. \overline{BWD} enables WRITES to DQd's and DQpd. \overline{BWE} enables WRITES to DQe's and DQpe. \overline{BWF} enables WRITES to DQf's and DQpf. \overline{BWg} enables WRITES to DQg's and DQpg. \overline{BWH} enables WRITES to DQh's and DQph. DQPa-DQPh are available on the x72 version. DQPa and DQpb are available on the x18 version. DQPa-DQpd are available on the x36 version.
4. All inputs except \overline{OE} and ZZ must meet setup and hold times around the rising edge (LOW to HIGH) of CLK.
5. Wait states are inserted by suspending burst.
6. For a WRITE operation following a READ operation, \overline{OE} must be HIGH before the input data setup time and held HIGH during the input data hold time.
7. This device contains circuitry that will ensure the outputs will be in High-Z during power-up.
8. \overline{ADSP} LOW always initiates an internal READ at the L-H edge of CLK. A WRITE is performed by setting one or more byte write enable signals and \overline{BWE} LOW or \overline{GW} LOW for the subsequent L-H edge of CLK. See WRITE timing diagram for clarification.



TRUTH TABLE⁽¹⁻⁸⁾ (1CE option)

| NEXT CYCLE | ADDRESS | \overline{CE} | \overline{ADSP} | \overline{ADSC} | \overline{ADV} | WRITE | \overline{OE} | DQ |
|-----------------------|----------|-----------------|-------------------|-------------------|------------------|-------|-----------------|--------|
| Deselected | None | H | X | L | X | X | X | High-Z |
| Read, Begin Burst | External | L | L | X | X | X | L | Q |
| Read, Begin Burst | External | L | L | X | X | X | H | High-Z |
| Write, Begin Burst | External | L | H | L | X | L | X | D |
| Read, Begin Burst | External | L | H | L | X | H | L | Q |
| Read, Begin Burst | External | L | H | L | X | H | H | High-Z |
| Read, Continue Burst | Next | X | H | H | L | H | L | Q |
| Read, Continue Burst | Next | X | H | H | L | H | H | High-Z |
| Read, Continue Burst | Next | H | X | H | L | H | L | Q |
| Read, Continue Burst | Next | H | X | H | L | H | H | High-Z |
| Write, Continue Burst | Next | X | H | H | L | L | X | D |
| Write, Continue Burst | Next | H | X | H | L | L | X | D |
| Read, Suspend Burst | Current | X | H | H | H | H | L | Q |
| Read, Suspend Burst | Current | X | H | H | H | H | H | High-Z |
| Read, Suspend Burst | Current | H | X | H | H | H | L | Q |
| Read, Suspend Burst | Current | H | X | H | H | H | H | High-Z |
| Write, Suspend Burst | Current | X | H | H | H | L | X | D |
| Write, Suspend Burst | Current | H | X | H | H | L | X | D |

NOTE:

1. X means "Don't Care." H means logic HIGH. L means logic LOW.
2. For **WRITE**, L means one or more byte write enable signals ($\overline{BWA-h}$) and \overline{BWE} are LOW or \overline{GW} is LOW. $\overline{WRITE} = H$ for all \overline{BWx} , \overline{BWE} , \overline{GW} HIGH.
3. \overline{BWA} enables WRITES to DQa's and DQP_a. \overline{BWB} enables WRITES to DQb's and DQP_b. \overline{BWC} enables WRITES to DQc's and DQP_c. \overline{BWD} enables WRITES to DQd's and DQP_d. \overline{BWE} enables WRITES to DQe's and DQP_e. \overline{BWF} enables WRITES to DQf's and DQP_f. \overline{BWg} enables WRITES to DQg's and DQP_g. \overline{BWH} enables WRITES to DQh's and DQP_h. DQP_a-DQP_h are available on the x72 version. DQP_a and DQP_b are available on the x18 version. DQP_a-DQP_d are available on the x36 version.
4. All inputs except \overline{OE} and ZZ must meet setup and hold times around the rising edge (LOW to HIGH) of CLK.
5. Wait states are inserted by suspending burst.
6. For a WRITE operation following a READ operation, \overline{OE} must be HIGH before the input data setup time and held HIGH during the input data hold time.
7. This device contains circuitry that will ensure the outputs will be in High-Z during power-up.
8. \overline{ADSP} LOW always initiates an internal READ at the L-H edge of CLK. A WRITE is performed by setting one or more byte write enable signals and \overline{BWE} LOW or \overline{GW} LOW for the subsequent L-H edge of CLK. See WRITE timing diagram for clarification.

PARTIAL TRUTH TABLE

| Function | \overline{GW} | \overline{BWE} | \overline{BWA} | \overline{BWB} | \overline{BWC} | \overline{BWD} | \overline{BWE} | \overline{BWF} | \overline{BWg} | \overline{BWh} |
|-----------------|-----------------|------------------|------------------|------------------|------------------|------------------|------------------|------------------|------------------|------------------|
| Read | H | H | X | X | X | X | X | X | X | X |
| Read | H | L | H | H | H | H | H | H | H | H |
| Write Byte 1 | H | L | L | H | H | H | H | H | H | H |
| Write All Bytes | H | L | L | L | L | L | L | L | L | L |
| Write All Bytes | L | X | X | X | X | X | X | X | X | X |

INTERLEAVED BURST ADDRESS TABLE (MODE = V_{DD} or No Connect)

| External Address A1 A0 | 1st Burst Address A1 A0 | 2nd Burst Address A1 A0 | 3rd Burst Address A1 A0 |
|---------------------------|----------------------------|----------------------------|----------------------------|
| 00 | 01 | 10 | 11 |
| 01 | 00 | 11 | 10 |
| 10 | 11 | 00 | 01 |
| 11 | 10 | 01 | 00 |

LINEAR BURST ADDRESS TABLE (MODE = V_{SS})

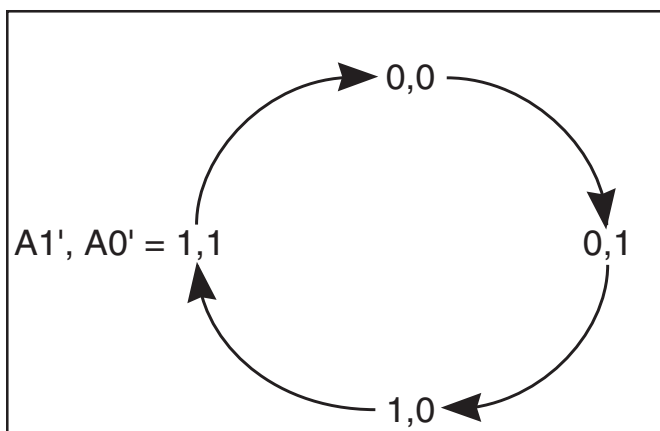

ABSOLUTE MAXIMUM RATINGS⁽¹⁾

| Symbol | Parameter | Value | Unit |
|------------------------------------|---|--------------------------------|------|
| T _{STG} | Storage Temperature | -55 to +150 | °C |
| P _D | Power Dissipation | 1.6 | W |
| I _{OUT} | Output Current (per I/O) | 100 | mA |
| V _{IN} , V _{OUT} | Voltage Relative to V _{SS} for I/O Pins | -0.5 to V _{DDQ} + 0.5 | V |
| V _{IN} | Voltage Relative to V _{SS} for for Address and Control Inputs | -0.5 to V _{DD} + 0.5 | V |
| V _{DD} | Voltage on V _{DD} Supply Relative to V _{SS} | -0.5 to 4.6 | V |

Notes:

1. Stress greater than those listed under ABSOLUTE MAXIMUM RATINGS may cause permanent damage to the device. This is a stress rating only and functional operation of the device at these or any other conditions above those indicated in the operational sections of this specification is not implied. Exposure to absolute maximum rating conditions for extended periods may affect reliability.
2. This device contains circuitry to protect the inputs against damage due to high static voltages or electric fields; however, precautions may be taken to avoid application of any voltage higher than maximum rated voltages to this high-impedance circuit.
3. This device contains circuitry that will ensure the output devices are in High-Z at power up.

OPERATING RANGE (IS61LFxxxx)

| Range | Ambient Temperature | V _{DD} | V _{DDQ} |
|------------|---------------------|-----------------|------------------|
| Commercial | 0°C to +70°C | 3.3V ± 5% | 3.3V/2.5V ± 5% |
| Industrial | -40°C to +85°C | 3.3V ± 5% | 3.3V/2.5V ± 5% |

OPERATING RANGE (IS61VFxxxx)

| Range | Ambient Temperature | V _{DD} | V _{DDQ} |
|------------|---------------------|-----------------|------------------|
| Commercial | 0°C to +70°C | 2.5V ± 5% | 2.5V ± 5% |
| Industrial | -40°C to +85°C | 2.5V ± 5% | 2.5V ± 5% |

DC ELECTRICAL CHARACTERISTICS (Over Operating Range)

| Symbol | Parameter | Test Conditions | 3.3V | | 2.5V | | Unit |
|-----------------|------------------------|--|------|-----------------------|------|-----------------------|------|
| | | | Min. | Max. | Min. | Max. | |
| V _{OH} | Output HIGH Voltage | I _{OH} = -4.0 mA (3.3V) I _{OH} = -1.0 mA (2.5V) | 2.4 | — | 2.0 | — | V |
| V _{OL} | Output LOW Voltage | I _{OL} = 8.0 mA (3.3V) I _{OL} = 1.0 mA (2.5V) | — | 0.4 | — | 0.4 | V |
| V _{IH} | Input HIGH Voltage | | 2.0 | V _{DD} + 0.3 | 1.7 | V _{DD} + 0.3 | V |
| V _{IL} | Input LOW Voltage | | -0.3 | 0.8 | -0.3 | 0.7 | V |
| I _{LI} | Input Leakage Current | V _{SS} ≤ V _{IN} ≤ V _{DD} ⁽¹⁾ | -5 | 5 | -5 | 5 | μA |
| I _{LO} | Output Leakage Current | V _{SS} ≤ V _{OUT} ≤ V _{DDQ} , $\overline{OE} = V_{IH}$ | -5 | 5 | -5 | 5 | μA |

Note:

- V_{IL} (min.) = -2.0V AC (pulse width - 2.0 ns). Not 100% tested.
 V_{IH} (max.) = V_{DD} + 2.0V AC (pulse width - 2.0 ns). Not 100% tested.

POWER SUPPLY CHARACTERISTICS⁽¹⁾ (Over Operating Range)

| Symbol | Parameter | Test Conditions | Temp. range | 6.5 MAX | | | 7.5 MAX | | Unit |
|------------------|-----------------------------|--|--------------|------------|------------|------------|------------|------------|------|
| | | | | x18 | x36 | x72 | x18 | x36 | |
| I _{CC} | AC Operating Supply Current | Device Selected, $\overline{OE} = V_{IH}$, ZZ ≤ V _{IL} , All Inputs ≤ 0.2V or ≥ V _{DD} - 0.2V, Cycle Time ≥ t _{kc} min. | Com. Ind. | 250 275 | 250 275 | 300 350 | 240 250 | 240 250 | mA |
| I _{SB} | Standby Current TTL Input | Device Deselected, V _{DD} = Max., All Inputs ≤ V _{IL} or ≥ V _{IH} , ZZ ≤ V _{IL} , f = Max. | Com. Ind. | 140 150 | 140 150 | 140 150 | 140 150 | 140 150 | mA |
| I _{SB1} | Standby Current CMOS Input | Device Deselected, V _{DD} = Max., V _{IN} ≤ V _{SS} + 0.2V or ≥ V _{DD} - 0.2V f = 0 | Com. Ind. | 110 125 | 110 125 | 110 125 | 110 125 | 110 125 | mA |
| I _{SB2} | Sleep Mode | ZZ > V _{IH} | Com. Ind. | 60 75 | 60 75 | 60 75 | 60 75 | 60 75 | mA |

Note:

- MODE pin has an internal pullup and should be tied to V_{DD} or V_{SS}. It exhibits ±100 μA maximum leakage current when tied to ≤ V_{SS} + 0.2V or ≥ V_{DD} - 0.2V.

CAPACITANCE^(1,2)

| Symbol | Parameter | Conditions | Max. | Unit |
|------------------|--------------------------|-----------------------|------|------|
| C _{IN} | Input Capacitance | V _{IN} = 0V | 6 | pF |
| C _{OUT} | Input/Output Capacitance | V _{OUT} = 0V | 8 | pF |

Notes:

1. Tested initially and after any design or process changes that may affect these parameters.
2. Test conditions: T_A = 25°C, f = 1 MHz, V_{DD} = 3.3V.

3.3V I/O AC TEST CONDITIONS

| Parameter | Unit |
|---|---------------------|
| Input Pulse Level | 0V to 3.0V |
| Input Rise and Fall Times | 1.5 ns |
| Input and Output Timing and Reference Level | 1.5V |
| Output Load | See Figures 1 and 2 |

AC TEST LOADS

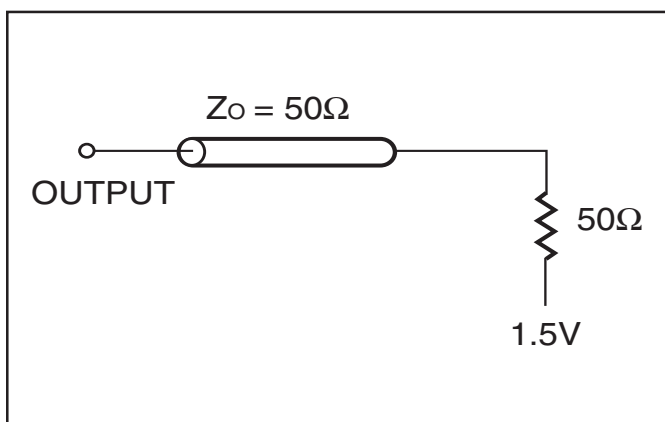

Figure 1

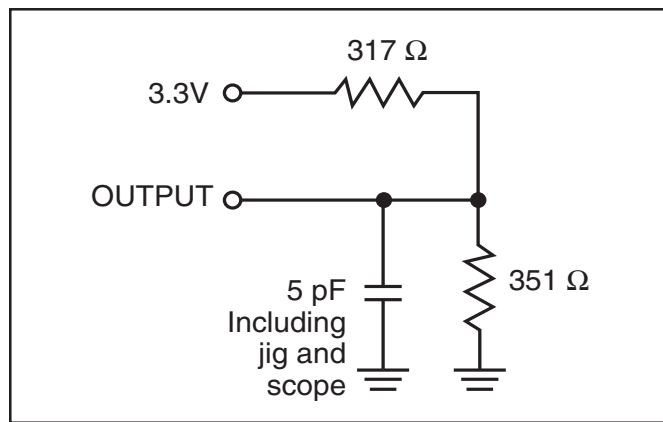

Figure 2

2.5V I/O AC TEST CONDITIONS

| Parameter | Unit |
|---|---------------------|
| Input Pulse Level | 0V to 2.5V |
| Input Rise and Fall Times | 1.5 ns |
| Input and Output Timing and Reference Level | 1.25V |
| Output Load | See Figures 3 and 4 |

2.5V I/O OUTPUT LOAD EQUIVALENT

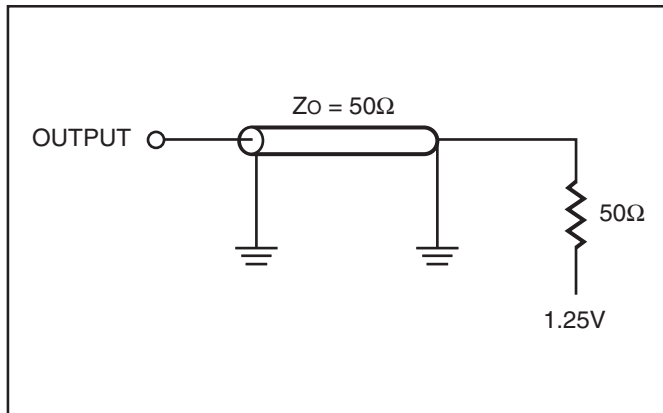

Figure 3



Figure 4



READ/WRITE CYCLE SWITCHING CHARACTERISTICS⁽¹⁾ (Over Operating Range)

| Symbol | Parameter | 6.5 | | 7.5 | | Unit |
|------------------------------------|---------------------------------|------|------|------|------|------|
| | | Min. | Max. | Min. | Max. | |
| f _{max} | Clock Frequency | — | 133 | — | 117 | MHz |
| t _{kc} | Cycle Time | 7.5 | — | 8.5 | — | ns |
| t _{kh} | Clock High Time | 2.2 | — | 2.5 | — | ns |
| t _{kl} | Clock Low Time | 2.2 | — | 2.5 | — | ns |
| t _{kq} | Clock Access Time | — | 6.5 | — | 7.5 | ns |
| t _{kqx} ⁽²⁾ | Clock High to Output Invalid | 2.5 | — | 2.5 | — | ns |
| t _{kqlz} ^(2,3) | Clock High to Output Low-Z | 2.5 | — | 2.5 | — | ns |
| t _{kqhz} ^(2,3) | Clock High to Output High-Z | — | 3.8 | — | 4.0 | ns |
| t _{oeq} | Output Enable to Output Valid | — | 3.2 | — | 3.4 | ns |
| t _{oelz} ^(2,3) | Output Enable to Output Low-Z | 0 | — | 0 | — | ns |
| t _{oehz} ^(2,3) | Output Disable to Output High-Z | — | 3.5 | — | 3.5 | ns |
| t _{as} | Address Setup Time | 1.5 | — | 1.5 | — | ns |
| t _{ws} | Read/Write Setup Time | 1.5 | — | 1.5 | — | ns |
| t _{ces} | Chip Enable Setup Time | 1.5 | — | 1.5 | — | ns |
| t _{avs} | Address Advance Setup Time | 1.5 | — | 1.5 | — | ns |
| t _{ds} | Data Setup Time | 1.5 | — | 1.5 | — | ns |
| t _{ah} | Address Hold Time | 0.5 | — | 0.5 | — | ns |
| t _{wh} | Write Hold Time | 0.5 | — | 0.5 | — | ns |
| t _{ceh} | Chip Enable Hold Time | 0.5 | — | 0.5 | — | ns |
| t _{avh} | Address Advance Hold Time | 0.5 | — | 0.5 | — | ns |
| t _{dh} | Data Hold Time | 0.5 | — | 0.5 | — | ns |
| t _{pds} | ZZ High to Power Down | — | 2 | — | 2 | cyc |
| t _{pds} | ZZ Low to Power Down | — | 2 | — | 2 | cyc |

Notes:

1. Configuration signal MODE is static and must not change during normal operation.
2. Guaranteed but not 100% tested. This parameter is periodically sampled.
3. Tested with load in Figure 2.

READ/WRITE CYCLE TIMING



WRITE CYCLE TIMING



SNOOZE MODE ELECTRICAL CHARACTERISTICS

| Symbol | Parameter | Conditions | Min. | Max. | Unit |
|--------|------------------------------------|------------|------|------|-------|
| ISB2 | Current during SNOOZE MODE | ZZ ≥ Vih | — | 60 | mA |
| tPDS | ZZ active to input ignored | | — | 2 | cycle |
| tPUS | ZZ inactive to input sampled | | 2 | — | cycle |
| tZZI | ZZ active to SNOOZE current | | — | 2 | cycle |
| tRZZI | ZZ inactive to exit SNOOZE current | | 0 | — | ns |

SNOOZE MODE TIMING



IEEE 1149.1 SERIAL BOUNDARY SCAN (JTAG)

The IS61LF/VF51236A and IS61LF/VF102418A have a serial boundary scan Test Access Port (TAP) in the PBGA package only. This port operates in accordance with IEEE Standard 1149.1-1900, but does not include all functions required for full 1149.1 compliance. These functions from the IEEE specification are excluded because they place added delay in the critical speed path of the SRAM. The TAP controller operates in a manner that does not conflict with the performance of other devices using 1149.1 fully compliant TAPs. The TAP operates using JEDEC standard 2.5V I/O logic levels.

DISABLING THE JTAG FEATURE

The SRAM can operate without using the JTAG feature. To disable the TAP controller, TCK must be tied LOW (V_{SS}) to prevent clocking of the device. TDI and TMS are internally pulled up and may be disconnected. They may alternately be connected to V_{DD} through a pull-up resistor. TDO should be left disconnected. On power-up, the device will start in a reset state which will not interfere with the device operation.

TEST ACCESS PORT (TAP) - TEST CLOCK

The test clock is only used with the TAP controller. All inputs are captured on the rising edge of TCK and outputs are driven from the falling edge of TCK.

TEST MODE SELECT (TMS)

The TMS input is used to send commands to the TAP controller and is sampled on the rising edge of TCK. This pin may be left disconnected if the TAP is not used. The pin is internally pulled up, resulting in a logic HIGH level.

TEST DATA-IN (TDI)

The TDI pin is used to serially input information to the registers and can be connected to the input of any register. The register between TDI and TDO is chosen by the instruction loaded into the TAP instruction register. For information on instruction register loading, see the TAP Controller State Diagram. TDI is internally pulled up and can be disconnected if the TAP is unused in an application. TDI is connected to the Most Significant Bit (MSB) on any register.

TAP CONTROLLER BLOCK DIAGRAM

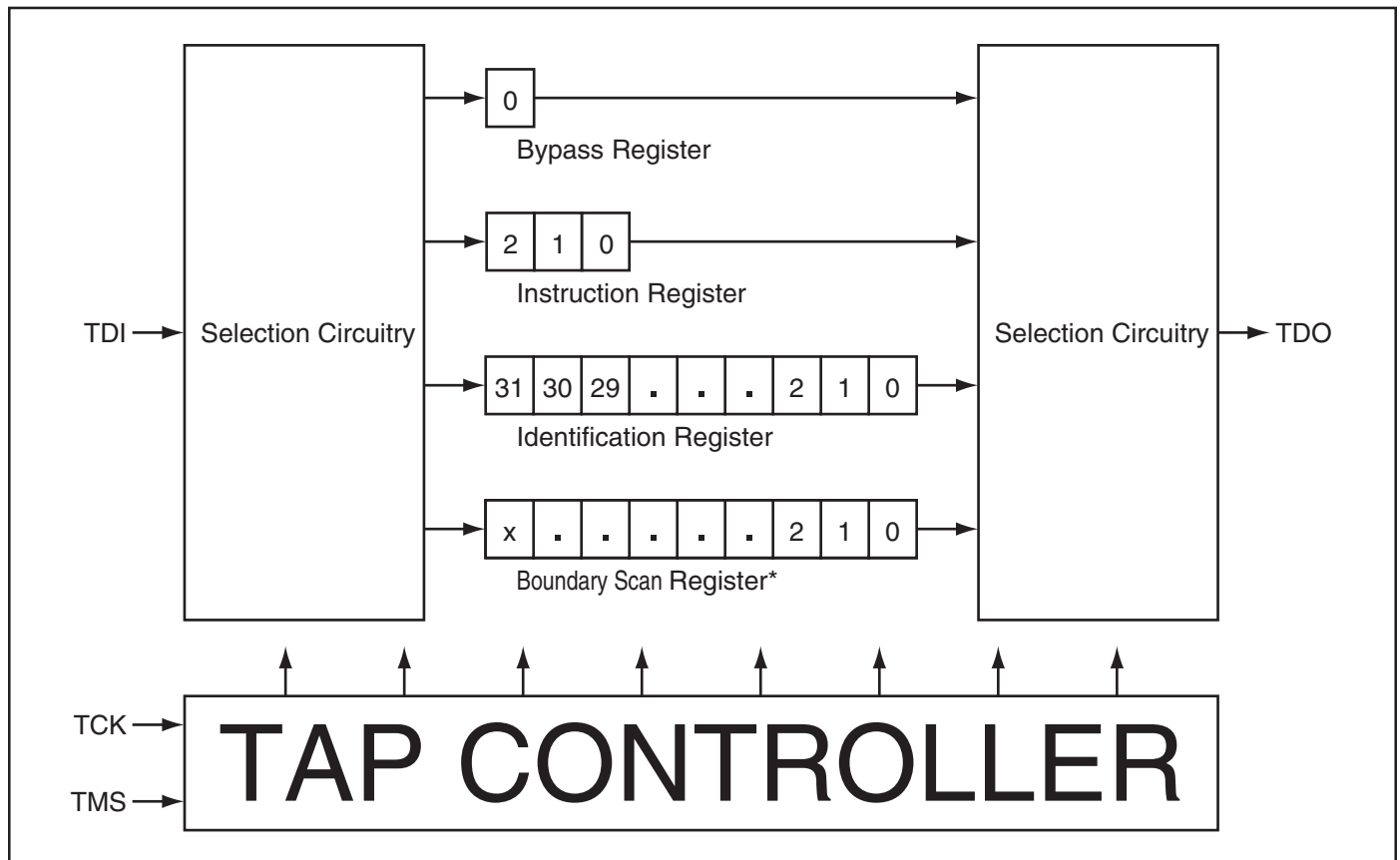

TEST DATA OUT (TDO)

The TDO output pin is used to serially clock data-out from the registers. The output is active depending on the current state of the TAP state machine (see TAP Controller State Diagram). The output changes on the falling edge of TCK and TDO is connected to the Least Significant Bit (LSB) of any register.

PERFORMING A TAP RESET

A Reset is performed by forcing TMS HIGH (V_{DD}) for five rising edges of TCK. RESET may be performed while the SRAM is operating and does not affect its operation. At power-up, the TAP is internally reset to ensure that TDO comes up in a high-Z state.

TAP REGISTERS

Registers are connected between the TDI and TDO pins and allow data to be scanned into and out of the SRAM test circuitry. Only one register can be selected at a time through the instruction registers. Data is serially loaded into the TDI pin on the rising edge of TCK and output on the TDO pin on the falling edge of TCK.

Instruction Register

Three-bit instructions can be serially loaded into the instruction register. This register is loaded when it is placed between the TDI and TDO pins. (See TAP Controller Block Diagram) At power-up, the instruction register is loaded with the IDCODE instruction. It is also loaded with the IDCODE instruction if the controller is placed in a reset state as previously described.

When the TAP controller is in the CaptureIR state, the two least significant bits are loaded with a binary "01" pattern to allow for fault isolation of the board level serial test path.

Bypass Register

To save time when serially shifting data through registers, it is sometimes advantageous to skip certain states. The bypass register is a single-bit register that can be placed between TDI and TDO pins. This allows data to be shifted through the SRAM with minimal delay. The bypass register

is set LOW (V_{SS}) when the BYPASS instruction is executed.

Boundary Scan Register

The boundary scan register is connected to all input and output pins on the SRAM. Several no connect (NC) pins are also included in the scan register to reserve pins for higher density devices. The x36 configuration has a 75-bit-long register and the x18 configuration also has a 75-bit-long register. The boundary scan register is loaded with the contents of the RAM Input and Output ring when the TAP controller is in the Capture-DR state and then placed between the TDI and TDO pins when the controller is moved to the Shift-DR state. The EXTEST, SAMPLE/PRELOAD and SAMPLE-Z instructions can be used to capture the contents of the Input and Output ring.

The Boundary Scan Order tables show the order in which the bits are connected. Each bit corresponds to one of the bumps on the SRAM package. The MSB of the register is connected to TDI, and the LSB is connected to TDO.

Scan Register Sizes

| Register Name | Bit Size (x18) | Bit Size (x36) | Bit Size (x72) |
|---------------|----------------|----------------|----------------|
| Instruction | 3 | 3 | 3 |
| Bypass | 1 | 1 | 1 |
| ID | 32 | 32 | 32 |
| Boundary Scan | 75 | 75 | TBD |

Identification (ID) Register

The ID register is loaded with a vendor-specific, 32-bit code during the Capture-DR state when the IDCODE command is loaded to the instruction register. The IDCODE is hardwired into the SRAM and can be shifted out when the TAP controller is in the Shift-DR state. The ID register has vendor code and other information described in the Identification Register Definitions table.

IDENTIFICATION REGISTER DEFINITIONS

| Instruction Field | Description | 256Kx72 | 512K x 36 | 1M x 18 |
|--------------------------|--|-------------|-------------|-------------|
| Revision Number (31:28) | Reserved for version number. | xxxx | xxxx | xxxx |
| Device Depth (27:23) | Defines depth of SRAM. 512K or 1M | 00110 | 00111 | 01000 |
| Device Width (22:18) | Defines width of the SRAM. x36 or x18 | 00101 | 00100 | 00011 |
| ISSI Device ID (17:12) | Reserved for future use. | xxxxx | xxxxx | xxxxx |
| ISSI JEDEC ID (11:1) | Allows unique identification of SRAM vendor. | 00011010101 | 00011010101 | 00011010101 |
| ID Register Presence (0) | Indicate the presence of an ID register. | 1 | 1 | 1 |

TAP INSTRUCTION SET

Eight instructions are possible with the three-bit instruction register and all combinations are listed in the Instruction Code table. Three instructions are listed as RESERVED and should not be used and the other five instructions are described below. The TAP controller used in this SRAM is not fully compliant with the 1149.1 convention because some mandatory instructions are not fully implemented. The TAP controller cannot be used to load address, data or control signals and cannot preload the Input or Output buffers. The SRAM does not implement the 1149.1 commands EXTEST or INTEST or the PRELOAD portion of SAMPLE/PRELOAD; instead it performs a capture of the Inputs and Output ring when these instructions are executed. Instructions are loaded into the TAP controller during the Shift-IR state when the instruction register is placed between TDI and TDO. During this state, instructions are shifted from the instruction register through the TDI and TDO pins. To execute an instruction once it is shifted in, the TAP controller must be moved into the Update-IR state.

EXTEST

EXTEST is a mandatory 1149.1 instruction which is to be executed whenever the instruction register is loaded with all 0s. Because EXTEST is not implemented in the TAP controller, this device is not 1149.1 standard compliant. The TAP controller recognizes an all-0 instruction. When an EXTEST instruction is loaded into the instruction register, the SRAM responds as if a SAMPLE/PRELOAD instruction has been loaded. There is a difference between the instructions, unlike the SAMPLE/PRELOAD instruction, EXTEST places the SRAM outputs in a High-Z state.

IDCODE

The IDCODE instruction causes a vendor-specific, 32-bit code to be loaded into the instruction register. It also places the instruction register between the TDI and TDO pins and allows the IDCODE to be shifted out of the device when the TAP controller enters the Shift-DR state. The IDCODE instruction is loaded into the instruction register upon power-up or whenever the TAP controller is given a test logic reset state.

SAMPLE-Z

The SAMPLE-Z instruction causes the boundary scan register to be connected between the TDI and TDO pins when the TAP controller is in a Shift-DR state. It also places all SRAM outputs into a High-Z state.

SAMPLE/PRELOAD

SAMPLE/PRELOAD is a 1149.1 mandatory instruction. The PRELOAD portion of this instruction is not implemented, so the TAP controller is not fully 1149.1 compliant. When the SAMPLE/PRELOAD instruction is loaded to the instruction register and the TAP controller is in the Capture-DR state, a snapshot of data on the inputs and output pins is captured in the boundary scan register.

It is important to realize that the TAP controller clock operates at a frequency up to 10 MHz, while the SRAM clock runs more than an order of magnitude faster. Because of the clock frequency differences, it is possible that during the Capture-DR state, an input or output will undergo a transition. The TAP may attempt a signal capture while in transition (metastable state). The device will not be harmed, but there is no guarantee of the value that will be captured or repeatable results.

To guarantee that the boundary scan register will capture the correct signal value, the SRAM signal must be stabilized long enough to meet the TAP controller's capture set-up plus hold times (t_{cs} and t_{ch}). To insure that the SRAM clock input is captured correctly, designs need a way to stop (or slow) the clock during a SAMPLE/PRELOAD instruction. If this is not an issue, it is possible to capture all other signals and simply ignore the value of the CLK and **CLK** captured in the boundary scan register.

Once the data is captured, it is possible to shift out the data by putting the TAP into the Shift-DR state. This places the boundary scan register between the TDI and TDO pins.

Note that since the PRELOAD part of the command is not implemented, putting the TAP into the Update to the Update-DR state while performing a SAMPLE/PRELOAD instruction will have the same effect as the Pause-DR command.

BYPASS

When the BYPASS instruction is loaded in the instruction register and the TAP is placed in a Shift-DR state, the bypass register is placed between the TDI and TDO pins. The advantage of the BYPASS instruction is that it shortens the boundary scan path when multiple devices are connected together on a board.

RESERVED

These instructions are not implemented but are reserved for future use. Do not use these instructions.

INSTRUCTION CODES

| Code | Instruction | Description |
|------|----------------|--|
| 000 | EXTEST | Captures the Input/Output ring contents. Places the boundary scan register between the TDI and TDO. Forces all SRAM outputs to High-Z state. This instruction is not 1149.1 compliant. |
| 001 | IDCODE | Loads the ID register with the vendor ID code and places the register between TDI and TDO. This operation does not affect SRAM operation. |
| 010 | SAMPLE-Z | Captures the Input/Output contents. Places the boundary scan register between TDI and TDO. Forces all SRAM output drivers to a High-Z state. |
| 011 | RESERVED | Do Not Use: This instruction is reserved for future use. |
| 100 | SAMPLE/PRELOAD | Captures the Input/Output ring contents. Places the boundary scan register between TDI and TDO. Does not affect the SRAM operation. This instruction does not implement 1149.1 preload function and is therefore not 1149.1 compliant. |
| 101 | RESERVED | Do Not Use: This instruction is reserved for future use. |
| 110 | RESERVED | Do Not Use: This instruction is reserved for future use. |
| 111 | BYPASS | Places the bypass register between TDI and TDO. This operation does not affect SRAM operation. |

TAP CONTROLLER STATE DIAGRAM

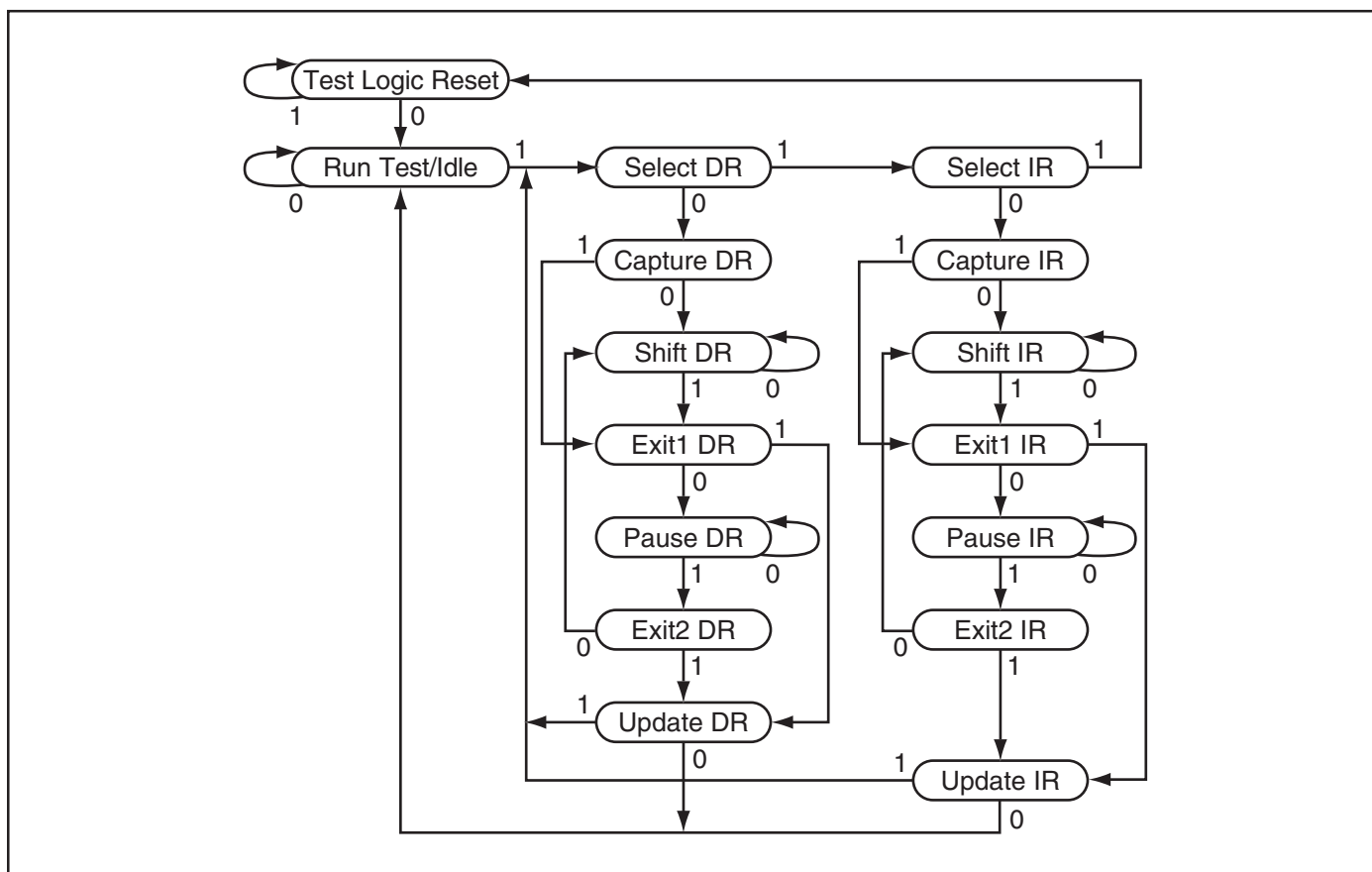

TAP Electrical Characteristics Over the Operating Range^(1,2)

| Symbol | Parameter | Test Conditions | Min. | Max. | Units |
|------------------|---------------------|---|------|----------------------|-------|
| V _{OH1} | Output HIGH Voltage | I _{OH} = -2.0 mA | 1.7 | — | V |
| V _{OH2} | Output HIGH Voltage | I _{OH} = -100 μA | 2.1 | — | V |
| V _{OL1} | Output LOW Voltage | I _{OL} = 2.0 mA | — | 0.7 | V |
| V _{OL2} | Output LOW Voltage | I _{OL} = 100 μA | — | 0.2 | V |
| V _{IH} | Input HIGH Voltage | | 1.7 | V _{DD} +0.3 | V |
| V _{IL} | Input LOW Voltage | I _{OLT} = 2mA | -0.3 | 0.7 | V |
| I _X | Input Load Current | V _{SS} ≤ V _I ≤ V _{DDQ} | -5 | 5 | mA |

Notes:

1. All Voltage referenced to Ground.
2. Overshoot: V_{IH} (AC) ≤ V_{DD} +1.5V for t ≤ t_{TCYC}/2,
 Undershoot: V_{IL} (AC) ≤ 0.5V for t ≤ t_{TCYC}/2,
 Power-up: V_{IH} < 2.6V and V_{DD} < 2.4V and V_{DDQ} < 1.4V for t < 200 ms.

TAP AC ELECTRICAL CHARACTERISTICS^(1,2) (OVER OPERATING RANGE)

| Symbol | Parameter | Min. | Max. | Unit |
|-------------------|-------------------------------|------|------|------|
| t _{TCYC} | TCK Clock cycle time | 100 | — | ns |
| f _{TF} | TCK Clock frequency | — | 10 | MHz |
| t _{TH} | TCK Clock HIGH | 40 | — | ns |
| t _{TL} | TCK Clock LOW | 40 | — | ns |
| t _{TMSS} | TMS setup to TCK Clock Rise | 10 | — | ns |
| t _{TDIS} | TDI setup to TCK Clock Rise | 10 | — | ns |
| t _{CS} | Capture setup to TCK Rise | 10 | — | ns |
| t _{TMSh} | TMS hold after TCK Clock Rise | 10 | — | ns |
| t _{TDIH} | TDI Hold after Clock Rise | 10 | — | ns |
| t _{CH} | Capture hold after Clock Rise | 10 | — | ns |
| t _{TDOV} | TCK LOW to TDO valid | — | 20 | ns |
| t _{TDOX} | TCK LOW to TDO invalid | 0 | — | ns |

Notes:

1. Both t_{CS} and t_{CH} refer to the set-up and hold time requirements of latching data from the boundary scan register.
2. Test conditions are specified using the load in TAP AC test conditions. t_R/t_F = 1 ns.

TAP AC TEST CONDITIONS

| | |
|--------------------------------------|---------------------|
| Input pulse levels | 0 to 2.5V/0 to 3.0V |
| Input rise and fall times | 1ns |
| Input timing reference levels | 1.25V/1.5V |
| Output reference levels | 1.25V/1.5V |
| Test load termination supply voltage | 1.25V/1.5V |

TAP Output Load Equivalent

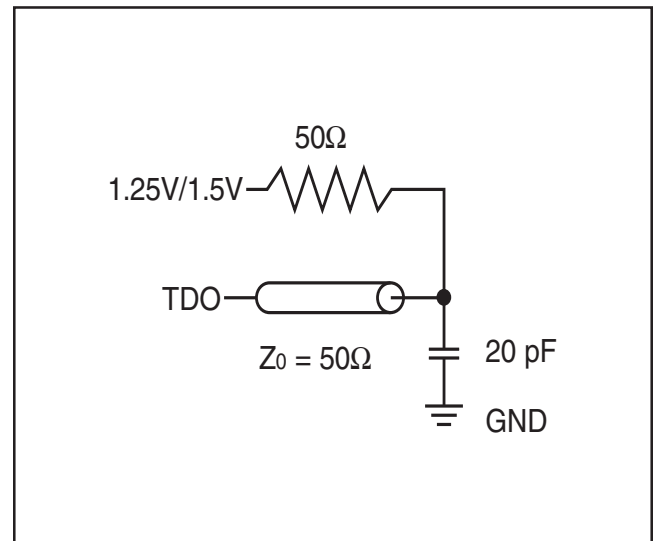

TAP TIMING

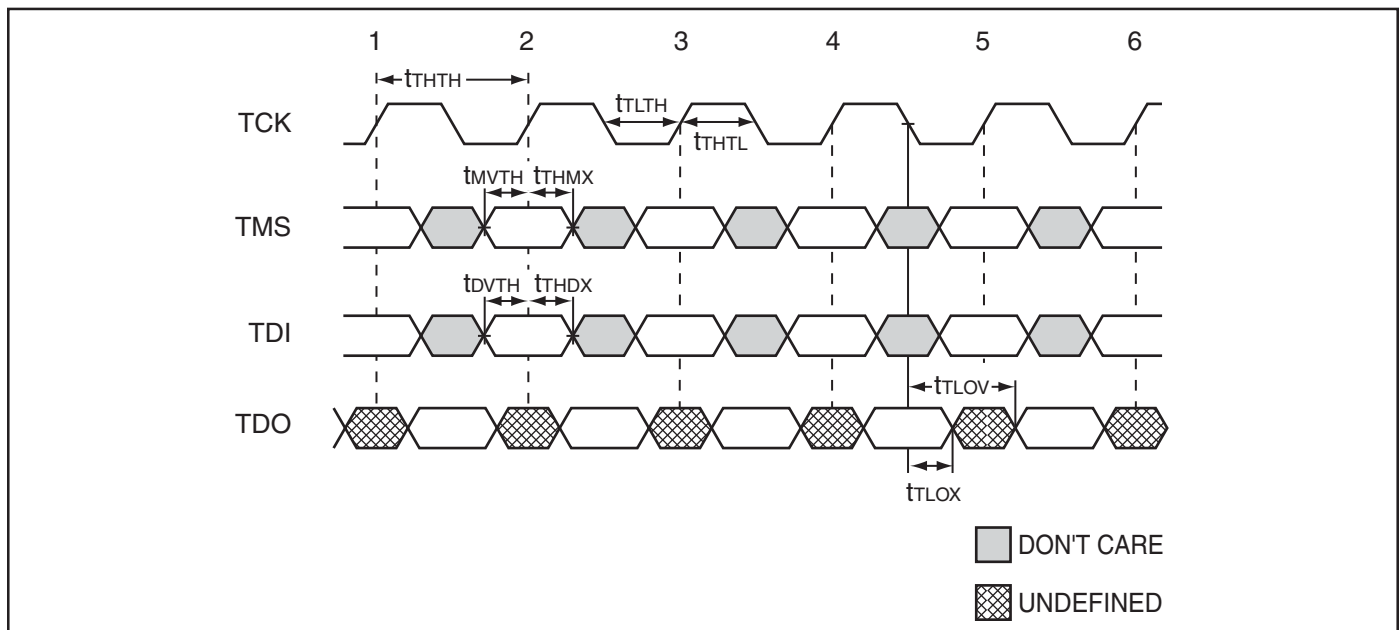



165 PBGA BOUNDARY SCAN ORDER (512K x 36)

| Bit # | Signal Name | Bump ID | Bit # | Signal Name | Bump ID | Bit # | Signal Name | Bump ID | Bit # | Signal Name | Bump ID |
|-------|-------------|---------|-------|-------------------|---------|-------|------------------|---------|-------|-------------|---------|
| 1 | MODE | 1R | 21 | DQb | 11G | 41 | NC | 1A | 61 | DQd | 1J |
| 2 | A | 6N | 22 | DQb | 11F | 42 | $\overline{CE}2$ | 6A | 62 | DQd | 1K |
| 3 | A | 11P | 23 | DQb | 11E | 43 | $\overline{BW}a$ | 5B | 63 | DQd | 1L |
| 4 | A | 8P | 24 | DQb | 11D | 44 | $\overline{BW}b$ | 5A | 64 | DQd | 1M |
| 5 | A | 8R | 25 | DQb | 10G | 45 | $\overline{BW}c$ | 4A | 65 | DQd | 2J |
| 6 | A | 9R | 26 | DQb | 10F | 46 | $\overline{BW}d$ | 4B | 66 | DQd | 2K |
| 7 | A | 9P | 27 | DQb | 10E | 47 | CE2 | 3B | 67 | DQd | 2L |
| 8 | A | 10P | 28 | DQb | 10D | 48 | \overline{CE} | 3A | 68 | DQd | 2M |
| 9 | A | 10R | 29 | DQb | 11C | 49 | A | 2A | 69 | DQd | 1N |
| 10 | A | 11R | 30 | NC | 11A | 50 | A | 2B | 70 | A | 3P |
| 11 | ZZ | 11H | 31 | A | 10A | 51 | NC | 1B | 71 | A | 3R |
| 12 | DQa | 11N | 32 | A | 10B | 52 | DQc | 1C | 72 | A | 4R |
| 13 | DQa | 11M | 33 | \overline{ADV} | 9A | 53 | DQc | 1D | 73 | A | 4P |
| 14 | DQa | 11L | 34 | \overline{ADSP} | 9B | 54 | DQc | 1E | 74 | A1 | 6P |
| 15 | DQa | 11K | 35 | \overline{ADSC} | 8A | 55 | DQc | 1F | 75 | A0 | 6R |
| 16 | DQa | 11J | 36 | \overline{OE} | 8B | 56 | DQc | 1G | | | |
| 17 | DQa | 10M | 37 | \overline{BWE} | 7A | 57 | DQc | 2D | | | |
| 18 | DQa | 10L | 38 | \overline{GW} | 7B | 58 | DQc | 2E | | | |
| 19 | DQa | 10K | 39 | CLK | 6B | 59 | DQc | 2F | | | |
| 20 | DQa | 10J | 40 | NC | 11B | 60 | DQc | 2G | | | |



165 PBGA BOUNDARY SCAN ORDER (1M x 18)

| Bit # | Signal Name | Bump ID | Bit # | Signal Name | Bump ID | Bit # | Signal Name | Bump ID | Bit # | Signal Name | Bump ID |
|-------|-------------|---------|-------|-------------------|---------|-------|------------------|---------|-------|-------------|---------|
| 1 | MODE | 1R | 21 | DQa | 11G | 41 | NC | 1A | 61 | DQb | 1J |
| 2 | A | 6N | 22 | DQa | 11F | 42 | $\overline{CE2}$ | 6A | 62 | DQb | 1K |
| 3 | A | 11P | 23 | DQa | 11E | 43 | \overline{BWa} | 5B | 63 | DQb | 1L |
| 4 | A | 8P | 24 | DQa | 11D | 44 | NC | 5A | 64 | DQb | 1M |
| 5 | A | 8R | 25 | DQa | 11C | 45 | \overline{BWb} | 4A | 65 | DQb | 1N |
| 6 | A | 9R | 26 | NC | 10F | 46 | NC | 4B | 66 | NC | 2K |
| 7 | A | 9P | 27 | NC | 10E | 47 | CE2 | 3B | 67 | NC | 2L |
| 8 | A | 10P | 28 | NC | 10D | 48 | \overline{CE} | 3A | 68 | NC | 2M |
| 9 | A | 10R | 29 | NC | 10G | 49 | A | 2A | 69 | NC | 2J |
| 10 | A | 11R | 30 | A | 11A | 50 | A | 2B | 70 | A | 3P |
| 11 | ZZ | 11H | 31 | A | 10A | 51 | NC | 1B | 71 | A | 3R |
| 12 | NC | 11N | 32 | A | 10B | 52 | NC | 1C | 72 | A | 4R |
| 13 | NC | 11M | 33 | \overline{ADV} | 9A | 53 | NC | 1D | 73 | A | 4P |
| 14 | NC | 11L | 34 | \overline{ADSP} | 9B | 54 | NC | 1E | 74 | A1 | 6P |
| 15 | NC | 11K | 35 | \overline{ADSC} | 8A | 55 | NC | 1F | 75 | A0 | 6R |
| 16 | NC | 11J | 36 | \overline{OE} | 8B | 56 | NC | 1G | | | |
| 17 | DQa | 10M | 37 | \overline{BWE} | 7A | 57 | DQb | 2D | | | |
| 18 | DQa | 10L | 38 | \overline{GW} | 7B | 58 | DQb | 2E | | | |
| 19 | DQa | 10K | 39 | CLK | 6B | 59 | DQb | 2F | | | |
| 20 | DQa | 10J | 40 | NC | 11B | 60 | DQb | 2G | | | |

209 BOUNDARY SCAN ORDER (256K X 72)





ORDERING INFORMATION ($V_{DD} = 3.3V/V_{DDQ} = 2.5V/3.3V$)

Commercial Range: 0°C to +70°C

| Configuration | Access Time | Order Part Number | Package |
|---------------|-------------|----------------------|---------------------|
| 256Kx72 | 6.5 | IS61LF25672A-6.5B1 | 209 PBGA |
| 512Kx36 | 6.5 | IS61LF51236A-6.5TQ | 100 TQFP |
| | | IS61LF51236A-6.5B2 | 119 PBGA |
| | | IS61LF51236A-6.5B3 | 165 PBGA |
| 512Kx36 | 7.5 | IS61LF51236A-7.5TQ | 100 TQFP |
| | | IS61LF51236A-7.5B2 | 119 PBGA |
| | | IS61LF51236A-7.5B3 | 165 PBGA |
| 1Mx18 | 6.5 | IS61LF102418A-6.5TQ | 100 TQFP |
| | | IS61LF102418A-6.5TQL | 100 TQFP, Lead-free |
| | | IS61LF102418A-6.5B2 | 119 PBGA |
| | | IS61LF102418A-6.5B3 | 165 PBGA |
| 1Mx18 | 7.5 | IS61LF102418A-7.5TQ | 100 TQFP |
| | | IS61LF102418A-7.5B2 | 119 PBGA |
| | | IS61LF102418A-7.5B3 | 165 PBGA |

Industrial Range: -40°C to +85°C

| Configuration | Access Time | Order Part Number | Package |
|---------------|-------------|-----------------------|---------------------|
| 256Kx72 | 6.5 | IS61LF25672A-6.5B1I | 209 PBGA |
| 512Kx36 | 6.5 | IS61LF51236A-6.5TQI | 100 TQFP |
| | | IS61LF51236A-6.5TQLI | 100 TQFP, Lead-free |
| | | IS61LF51236A-6.5B2I | 119 PBGA |
| | | IS61LF51236A-6.5B2LI | 119 PBGA, Lead-free |
| | | IS61LF51236A-6.5B3I | 165 PBGA |
| 512Kx36 | 7.5 | IS61LF51236A-7.5TQI | 100 TQFP |
| | | IS61LF51236A-7.5TQLI | 100 TQFP, Lead-free |
| | | IS61LF51236A-7.5B2I | 119 PBGA |
| | | IS61LF51236A-7.5B3I | 165 PBGA |
| | | IS61LF51236A-7.5B3LI | 165 PBGA, Lead-free |
| 1Mx18 | 6.5 | IS61LF102418A-6.5TQI | 100 TQFP |
| | | IS61LF102418A-6.5B2I | 119 PBGA |
| | | IS61LF102418A-6.5B3I | 165 PBGA |
| 1Mx18 | 7.5 | IS61LF102418A-7.5TQI | 100 TQFP |
| | | IS61LF102418A-7.5TQLI | 100 TQFP, Lead-free |
| | | IS61LF102418A-7.5B2I | 119 PBGA |
| | | IS61LF102418A-7.5B3I | 165 PBGA |
| | | IS61LF102418A-7.5B3LI | 165 PBGA, Lead-free |



ORDERING INFORMATION (V_{DD} = 2.5V /V_{DDQ} = 2.5V)

Commercial Range: 0°C to +70°C

| Configuration | Access Time | Order Part Number | Package |
|---------------|-------------|---------------------|----------|
| 256Kx72 | 6.5 | IS61VF25672A-6.5B1 | 209 PBGA |
| 512Kx36 | 6.5 | IS61VF51236A-6.5TQ | 100 TQFP |
| | | IS61VF51236A-6.5B2 | 119 PBGA |
| | | IS61VF51236A-6.5B3 | 165 PBGA |
| 512Kx36 | 7.5 | IS61VF51236A-7.5TQ | 100 TQFP |
| | | IS61VF51236A-7.5B2 | 119 PBGA |
| | | IS61VF51236A-7.5B3 | 165 PBGA |
| 1Mx18 | 6.5 | IS61VF102418A-6.5TQ | 100 TQFP |
| | | IS61VF102418A-6.5B2 | 119 PBGA |
| | | IS61VF102418A-6.5B3 | 165 PBGA |
| 1Mx18 | 7.5 | IS61VF102418A-7.5TQ | 100 TQFP |
| | | IS61VF102418A-7.5B2 | 119 PBGA |
| | | IS61VF102418A-7.5B3 | 165 PBGA |

Industrial Range: -40°C to +85°C

| Configuration | Access Time | Order Part Number | Package |
|---------------|-------------|----------------------|---------------------|
| 256Kx72 | 6.5 | IS61VF25672A-6.5B1I | 209 PBGA |
| 512Kx36 | 6.5 | IS61VF51236A-6.5TQI | 100 TQFP |
| | | IS61VF51236A-6.5B2I | 119 PBGA |
| | | IS61VF51236A-6.5B3I | 165 PBGA |
| 512Kx36 | 7.5 | IS61VF51236A-7.5TQI | 100 TQFP |
| | | IS61VF51236A-7.5TQLI | 100 TQFP, Lead-free |
| | | IS61VF51236A-7.5B2I | 119 PBGA |
| | | IS61VF51236A-7.5B3I | 165 PBGA |
| 1Mx18 | 6.5 | IS61VF102418A-6.5TQI | 100 TQFP |
| | | IS61VF102418A-6.5B2I | 119 PBGA |
| | | IS61VF102418A-6.5B3I | 165 PBGA |
| 1Mx18 | 7.5 | IS61VF102418A-7.5TQI | 100 TQFP |
| | | IS61VF102418A-7.5B2I | 119 PBGA |
| | | IS61VF102418A-7.5B3I | 165 PBGA |





| | | | | | | |
|--|-------|--|------|---|------|------------|
| | TITLE | 100L 14x20x1.4mm LQFP (Footprint : 2.0 mm) Package Outline | REV. | F | DATE | 09/01/2009 |
|--|-------|--|------|---|------|------------|

280-600-011 REV. A



| | | | | | | |
|--|--------------|--|-------------|----------|-------------|-------------------|
| | TITLE | 119L 14x22mm PBGA Package Outline | REV. | D | DATE | 10/02/2008 |
|--|--------------|--|-------------|----------|-------------|-------------------|



| SYM. | DIMENSION (mm) | | | DIMENSION (inch) | | |
|------|----------------|-------|-------|------------------|-------|-------|
| | MIN. | NOM. | MAX. | MIN. | NOM. | MAX. |
| A | — | — | 1.20 | — | — | 0.047 |
| A1 | 0.25 | 0.35 | 0.40 | 0.010 | 0.014 | 0.016 |
| A2 | — | 0.79 | — | — | 0.031 | — |
| b | 0.40 | 0.45 | 0.50 | 0.016 | 0.018 | 0.020 |
| D | 14.90 | 15.00 | 15.10 | 0.587 | 0.591 | 0.594 |
| D1 | 13.90 | 14.00 | 14.10 | 0.547 | 0.551 | 0.555 |
| E | 12.90 | 13.00 | 13.10 | 0.508 | 0.512 | 0.516 |
| E1 | 9.90 | 10.00 | 10.10 | 0.390 | 0.394 | 0.398 |
| ⓔ | 1.00 BSC | | | 0.039 BSC | | |

NOTE :
1. CONTROLLING DIMENSION : MM .

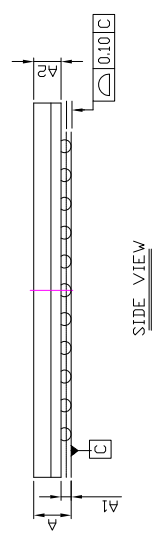

| | | | | |
|--|-------|--|--------|-----------------|
| | TITLE | 165L 13x15mm TF-BGA Package Outline | REV. B | DATE 08/28/2008 |
|--|-------|--|--------|-----------------|

Данный компонент на территории Российской Федерации

Вы можете приобрести в компании MosChip.

Для оперативного оформления запроса Вам необходимо перейти по данной ссылке:

<http://moschip.ru/get-element>

Вы можете разместить у нас заказ для любого Вашего проекта, будь то серийное производство или разработка единичного прибора.

В нашем ассортименте представлены ведущие мировые производители активных и пассивных электронных компонентов.

Нашей специализацией является поставка электронной компонентной базы двойного назначения, продукции таких производителей как XILINX, Intel (ex.ALTERA), Vicor, Microchip, Texas Instruments, Analog Devices, Mini-Circuits, Amphenol, Glenair.

Сотрудничество с глобальными дистрибьюторами электронных компонентов, предоставляет возможность заказывать и получать с международных складов практически любой перечень компонентов в оптимальные для Вас сроки.

На всех этапах разработки и производства наши партнеры могут получить квалифицированную поддержку опытных инженеров.

Система менеджмента качества компании отвечает требованиям в соответствии с ГОСТ Р ИСО 9001, ГОСТ РВ 0015-002 и ЭС РД 009

Офис по работе с юридическими лицами:

105318, г.Москва, ул.Щербаковская д.3, офис 1107, 1118, ДЦ «Щербаковский»

Телефон: +7 495 668-12-70 (многоканальный)

Факс: +7 495 668-12-70 (доб.304)

E-mail: info@moschip.ru

Skype отдела продаж:

moschip.ru

moschip.ru_4

moschip.ru_6

moschip.ru_9