

## LDO10C Series

### 50 Watts C-Class Non-Isolated

Total Power: 50 Watts  
Input Voltage: 3 - 13.8 Vdc  
No. of Outputs: Single

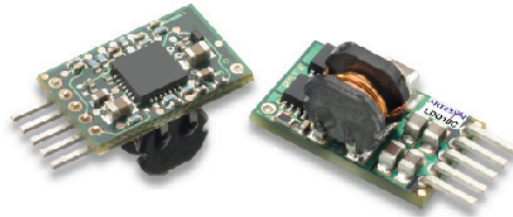

### Special Features

- 10 A current rating
- Adjustable output voltage: 0.59 - 5.1 V
- Excellent transient response
- Power enable (5 pin model)
- Minimum airflow
- Small package
- Termination voltage capability
- RoHS compliant

## Electrical Specifications

### Output

Output voltage	See Note 5	0.59 - 5.1 V
Output setpoint accuracy	0.1% trim resistors	± 1.0%
Line regulation	Low line to high line	± 0.2%
Load regulation	Full load to min. load	± 0.5%
Min./max. load		0 A/10 A
Overshoot	At turn-on	0.5% max.
Undershoot	At turn-off	100 mV max.
Ripple and noise 5 Hz to 20 MHz	See Note 1	20 mV Vin = 5 V, Vout = 2.5 V
Transient response	See Notes 1, 2	130 mV max. deviation 15 μs recovery to within regulation band

### Input

Input voltage range		3 - 13.8 Vdc
Input current	Minimum load Remote OFF	50 mA 5 mA
Input current (max.)	See Note 3	10 A @ Io max.
Start-up time	Power up Remote ON/OFF	3 ms 2 ms

### Safety

UL, cUL CAN/CSA 22.2  
No. E139421  
TÜV Product Service (EN60950)  
Certificate No. TBD  
CB Report and  
Certificate to IEC60950

## General

Efficiency (high input)	Vin=5 V, Vo=2.5 V, Io=10 A	91% typical
Switching frequency	Fixed	620 kHz
Approvals and standards (pending)		EN60950 UL/cUL6950
Material flammability		UL94V-0
Weight		1.899 g (0.067 oz.)
MTBF	12 V @ 40 °C, 100% load Bellcore 332	> 8,220,210 hours
Coplanarity	Surface mount models	150 μm

## Environmental Specifications

Thermal performance	Operating ambient, temperature	-40 °C to +85 °C
See Note 5	Non-operating	-40 °C to +125 °C

## Protection

Short-circuit	Hiccup, non-latching
---------------	----------------------

## Recommended System Capacitance

Input	See Note 6	0 μF
Output	See Note 7	0 μF

## Ordering Information

Output Power (Max.)	Input Voltage	OVP	Output Voltage	Output Current (Min.)	Output Current (Max.)	Efficiency (Typical)	Regulation Line	Regulation Load	Model Number <sup>(3,5)</sup>
50 W	3 - 13.8 Vdc	N/A	0.59 - 5.1 V	0 A	10 A	94%	± 0.2%	± 0.5%	LDO10C-005W05-VJ
50 W	3 - 13.8 Vdc	N/A	0.59 - 5.1 V	0 A	10 A	94%	± 0.2%	± 0.5%	LDO10C-005W05-HJ
50 W	3 - 13.8 Vdc	N/A	0.59 - 5.1 V	0 A	10 A	94%	± 0.2%	± 0.5%	LDO10C-005W05-SJ

## Part Number System with Options

Product Family	Rated Output Current	Performance	Input Voltage	Number of Pins and Type of Output	Output Voltage	Mounting Option	RoHS Compliance <sup>(8)</sup>
<b>LDO</b>	<b>10</b>	<b>C</b>	<b>00</b>	<b>5W</b>	<b>05</b>	<b>V</b>	<b>J</b>
Product Family LDO = C-Class LDO Series	Rated Output Current 10 = 10 Amp	Performance C = Cost Optimized	Input Voltage 00 = 3 - 13.8 V	Number of Pins and Type of Output 5W = 5 Pins and Wide Output	Output Voltage 05 = 0.59-5.1 V	Mounting Option V = Vertical H = Horizontal S = Surface	RoHS Compliance J = Pb free (RoHS 6/6 compliant) Y = non PB-free (TSE 5/6 compliant)

### Output Voltage Adjustment of the LDO03C Series

The ultra-wide output voltage trim range offers major advantages to users who select the LDO010C series. It is no longer necessary to purchase a variety of modules in order to cover different output voltages. The output voltage can be trimmed in a range of 0.59 - 5.1 Vdc. When the LDO03C converter leaves the factory, the output has been adjusted to the default voltage of 0.59 V.

#### Notes:

- 1 Measured as per recommended system capacitance. See Application Note 186.
- 2  $di/dt = 10 \text{ A}/\mu\text{s}$ ,  $V_{in} = \text{Nom}$ ,  $T_c = 25 \text{ }^\circ\text{C}$ , load change = 0.50 lo to full lo and full lo to 0.50.
- 3 External input fusing is recommended.
- 4 Additional part numbers may be available with different output voltages.
- 5 Airflow dependent, 100 LFM minimum required.
- 6 No capacitors needed for ripple current capability.
- 7 No capacitors needed for stability.
- 8 NOTICE: the input voltage must be greater than the programmed output voltage. the max duty cycle is 95%. These non-isolated dc-dc modules are buck converters.

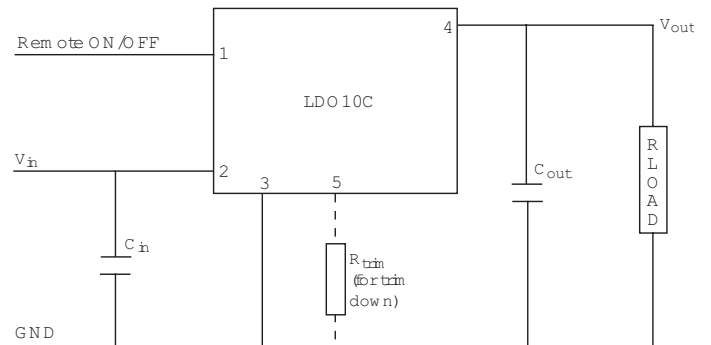

Figure 1: Standard Application Drawing

# Mechanical Drawings

## Vertical Mount

Dimensions in inches (mm). Tolerances (unless otherwise specified) 2 Places  $\pm 0.030$  ( $\pm 0.76$ ) 3 Places  $\pm 0.010$  ( $\pm 0.25$ )

### Pin Assignments

Pin No.	Function
1.	Enable
2.	Vin
3.	Common/RTN
4.	Vout
5.	Trim

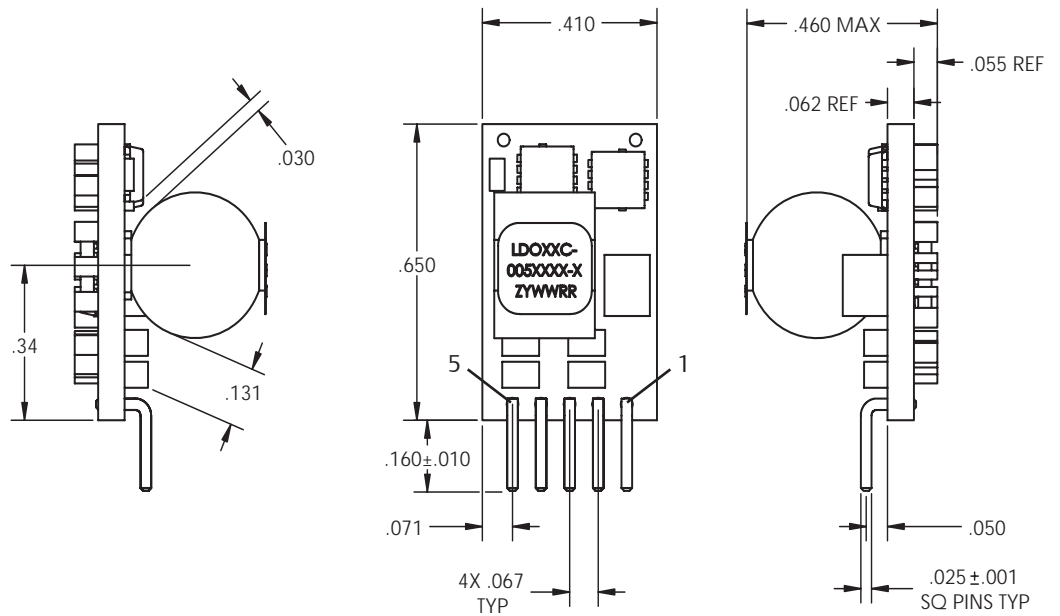

Figure 2: Vertical Mount Mechanical Drawing

## Horizontal Mount

Dimensions in inches (mm). Tolerances (unless otherwise specified) 2 Places  $\pm 0.030$  ( $\pm 0.76$ ) 3 Places  $\pm 0.010$  ( $\pm 0.25$ )

### Pin Assignments

Pin No.	Function
1.	Enable
2.	Vin
3.	Common/RTN
4.	Vout
5.	Trim
6.	Mech Pin

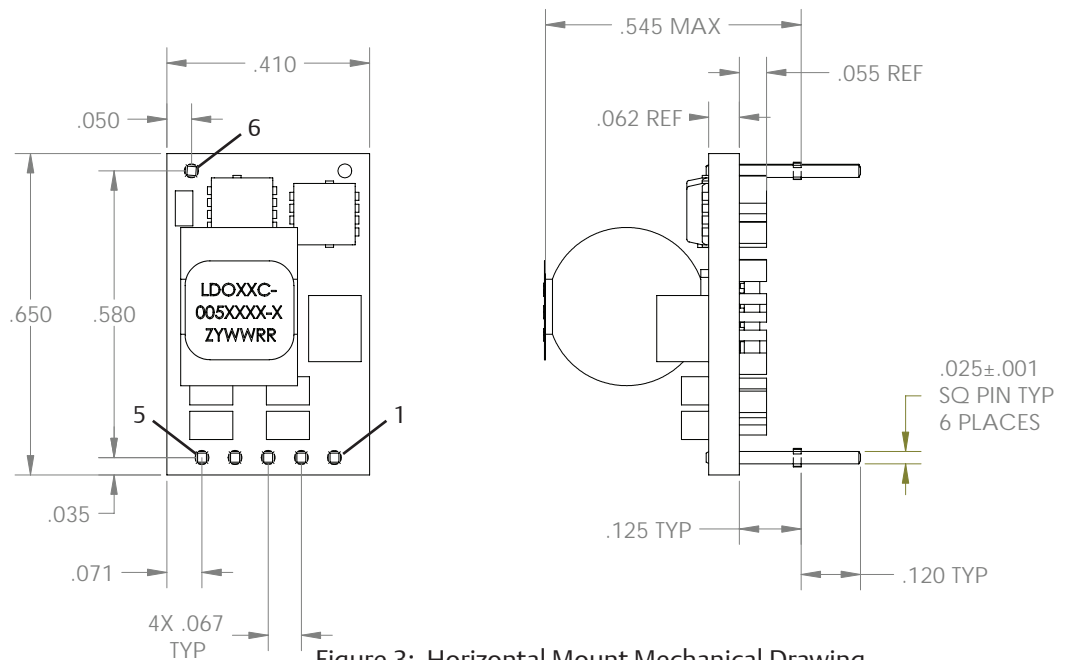

Figure 3: Horizontal Mount Mechanical Drawing

## Surface Mount

Dimensions in inches (mm). Tolerances (unless otherwise specified) 2 Places  $\pm 0.030$  ( $\pm 0.76$ )  
3 Places  $\pm 0.010$  ( $\pm 0.25$ )

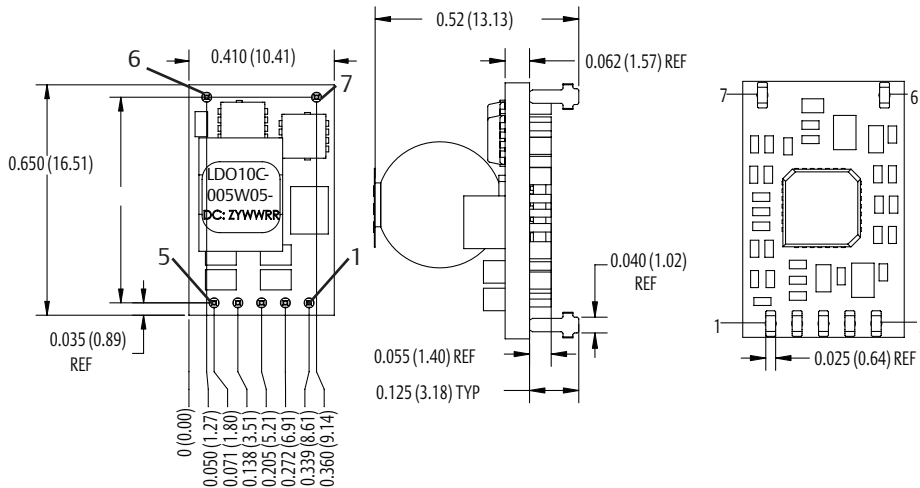

Figure 4: Surface Mount Mechanical Drawing

## Pin Assignments

Pin No.	Function
1.	Enable
2.	Vin
3.	Common/RTN
4.	Vout
5.	Trim
6.	Mech Pin
7.	Mech Pin

## Americas

5810 Van Allen Way  
Carlsbad, CA 92008  
USA  
Telephone: +1 760 930 4600  
Facsimile: +1 760 930 0698

## Europe (UK)

Waterfront Business Park  
Merry Hill, Dudley  
West Midlands, DY5 1LX  
United Kingdom  
Telephone: +44 (0) 1384 842 211  
Facsimile: +44 (0) 1384 843 355

## Asia (HK)

1/F, Lu Plaza  
2 Wing Yip Street  
Kwun Tong, Kowloon  
Hong Kong  
Telephone: +852 2176 3333  
Facsimile: +852 2176 3888

For global contact, visit:

[www.Emerson.com/  
EmbeddedPower  
techsupport.embeddedpower  
@emerson.com](http://www.Emerson.com/EmbeddedPowertechsupport.embeddedpower@emerson.com)

While every precaution has been taken to ensure accuracy and completeness in this literature, Emerson Network Power assumes no responsibility, and disclaims all liability for damages resulting from use of this information or for any errors or omissions.

## Emerson Network Power.

The global leader in enabling business-critical continuity.

- AC Power
- Connectivity
- DC Power
- Embedded Computing
- **Embedded Power**
- Monitoring
- Outside Plant
- Power Switching & controls
- Precision Cooling
- Racks & Integrated Cabinets
- Services
- Surge Protection

[EmersonNetworkPower.com](http://EmersonNetworkPower.com)

Emerson Network Power and the Emerson Network Power logo are trademarks and service marks of Emerson Electric Co.  
©2010 Emerson Electric Co.

## Данный компонент на территории Российской Федерации

### Вы можете приобрести в компании MosChip.

Для оперативного оформления запроса Вам необходимо перейти по данной ссылке:

<http://moschip.ru/get-element>

Вы можете разместить у нас заказ для любого Вашего проекта, будь то серийное производство или разработка единичного прибора.

В нашем ассортименте представлены ведущие мировые производители активных и пассивных электронных компонентов.

Нашей специализацией является поставка электронной компонентной базы двойного назначения, продукции таких производителей как XILINX, Intel (ex.ALTERA), Vicor, Microchip, Texas Instruments, Analog Devices, Mini-Circuits, Amphenol, Glenair.

Сотрудничество с глобальными дистрибьюторами электронных компонентов, предоставляет возможность заказывать и получать с международных складов практически любой перечень компонентов в оптимальные для Вас сроки.

На всех этапах разработки и производства наши партнеры могут получить квалифицированную поддержку опытных инженеров.

Система менеджмента качества компании отвечает требованиям в соответствии с ГОСТ Р ИСО 9001, ГОСТ РВ 0015-002 и ЭС РД 009

### Офис по работе с юридическими лицами:

105318, г.Москва, ул.Щербаковская д.3, офис 1107, 1118, ДЦ «Щербаковский»

Телефон: +7 495 668-12-70 (многоканальный)

Факс: +7 495 668-12-70 (доб.304)

E-mail: [info@moschip.ru](mailto:info@moschip.ru)

Skype отдела продаж:

moschip.ru

moschip.ru\_4

moschip.ru\_6

moschip.ru\_9