



12-/16-Bit DASs with ADC, DACs, DPIOs, APIOs, Reference, Voltage Monitors, and Temp Sensor

MAX1329/MAX1330

General Description

The MAX1329/MAX1330 are smart data acquisition systems (DASs) based on a successive approximation register (SAR) analog-to-digital converter (ADC). These devices are highly integrated, offering an ADC, digital-to-analog converters (DACs), operational amplifiers (op amps), voltage reference, temperature sensors, and analog switches in the same device.

The MAX1329/MAX1330 offer a single ADC with a reference buffer. The ADC is capable of operating in one of two user-programmable modes. In normal mode, the ADC provides up to 12 bits of resolution at 312ksps. In DSP mode, the ADC provides up to 16 bits of resolution at 1000sps. The ADC accepts one external differential input or two external single-ended inputs as well as inputs from other circuitry on-board. An on-chip programmable gain amplifier (PGA) follows the analog inputs, reducing external circuitry requirements. The PGA gain is adjustable from 1V/V to 8V/V.

The MAX1329/MAX1330 operate from a 1.8V to 3.6V digital power supply. Shutdown and sleep modes are available for power-saving applications. Under normal operation, an internal charge pump boosts the supply voltage for the analog circuitry when the supply is < 2.7V.

The MAX1329/MAX1330 offer four analog programmable I/Os (APIOs) and four digital programmable I/Os (DPIOs). The APIOs can be configured as general-purpose logic inputs and outputs, as a wake-up function, or as a buffer and level shifter for the serial interface to communicate with slave devices powered by the analog supply, AVDD. The DPIOs can be configured as general-purpose logic inputs and outputs as well as inputs to directly control the ADC conversion rate, the analog switches, the loading of the DACs, wake-up, sleep, and shutdown modes, and as an interrupt for when the analog-to-digital conversion is complete.

The MAX1329 includes dual 12-bit force-sense DACs with a programmable reference buffer and one op amp. The MAX1330 provides one 12-bit force-sense DAC with a programmable reference buffer and two op amps. For the MAX1329/MAX1330, a 16-word DAC FIFO can be used with the DACA for direct digital synthesis (DDS) of waveforms.

The 4-wire serial interface is compatible with SPI™, QSPI™, and MICROWIRE™.

Applications

- Battery-Powered and Portable Devices
- Electrochemical and Optical Sensors
- Medical Instruments
- Industrial Control
- Data Acquisition Systems
- Low-Cost CODECs

SPI/QSPI are trademarks of Motorola, Inc.

MICROWIRE is a trademark of National Semiconductor Corp.



Maxim Integrated Products 1

For pricing delivery, and ordering information please contact Maxim Direct at 1-888-629-4642, or visit Maxim's website at www.maxim-ic.com.

Features

- ◆ 1.8V to 3.6V Single Digital Supply Operation
- ◆ Internal Charge Pump for Analog Circuits (2.7V to 5.5V)
- ◆ 12-Bit SAR ADC
 - 12 Bits, 312ksps, No Missing Codes
 - 16 Bits, 1000sps, DSP Mode
 - 16-Word FIFO and 20-Bit Accumulator
 - PGA with Gains of 1, 2, 4, and 8
 - Unipolar and Bipolar Modes
 - 16-Input Differential Multiplexer
- ◆ Dual 12-Bit Force-Sense DACs
 - 16-Word FIFO (DACA Only)
- ◆ Independent Voltage References for ADC and DACs
 - Internal 2.5V Reference
 - Adjustable Reference Buffers Provide 1.25V, 2.048V, or 2.5V
- ◆ System Support
 - ADC Alarm Register
 - Uncommitted Op Amps
 - Dual SPDT Analog Switches
 - Internal/External Temperature Sensor
 - Internal Oscillator with Clock I/O
 - Digital Programmable I/O
 - Analog Programmable I/O
 - Programmable Interrupts
 - Accurate Supply Voltage Measurement
 - Programmable Dual Voltage Monitors
- ◆ SPI-/QSPI-/MICROWIRE-Compatible, 4-Wire Serial Interface
- ◆ Space-Saving, 6mm x 6mm, 40-Pin Thin QFN Package

Ordering Information

PART	TEMP RANGE	PIN-PACKAGE
MAX1329BETL+	-40°C to +85°C	40 Thin QFN-EP**
MAX1330BETL+*	-40°C to +85°C	40 Thin QFN-EP**

*Future product—contact factory for availability.

**EP = Exposed pad.

+Denotes a lead-free/RoHS-compliant package.

Pin Configurations appear at end of data sheet.

12-/16-Bit DASs with ADC, DACs, DPIOs, APIOs, Reference, Voltage Monitors, and Temp Sensor

ABSOLUTE MAXIMUM RATINGS

AV _{DD} to AGND	-0.3V to +6V
DV _{DD} to DGND	-0.3V to +6V
Analog Inputs to AGND	-0.3V to the lower of (AV _{DD} + 0.3V) or +6V
Digital Inputs to DGND	-0.3V to the lower of (DV _{DD} + 0.3V) or +6V
Analog Outputs to AGND	-0.3V to the lower of (AV _{DD} + 0.3V) or +6V
Digital Outputs to DGND	-0.3V to the lower of (DV _{DD} + 0.3V) or 6V

AGND to DGND	-0.3V to +0.3V
Continuous Current into Any Pin	±50mA
Continuous Power Dissipation (T _A = +70°C) 40-Pin Thin QFN (derate 37mW/°C above +70°C)	2963mW
Operation Temperature Range	-40°C to +85°C
Storage Temperature Range	-65°C to +150°C
Junction Temperature	+150°C
Lead Temperature (soldering, 10s)	+300°C

Stresses beyond those listed under "Absolute Maximum Ratings" may cause permanent damage to the device. These are stress ratings only, and functional operation of the device at these or any other conditions beyond those indicated in the operational sections of the specifications is not implied. Exposure to absolute maximum rating conditions for extended periods may affect device reliability.

ELECTRICAL CHARACTERISTICS

(DV_{DD} = 1.8V to 3.6V, AV_{DD} = 2.7V to 5.5V, V_{REFDAC} = V_{REFADC} = 2.5V, external reference; 10µF capacitor at REFADC and REFDAC; 0.01µF capacitor at REFADJ; T_A = T_{MIN} to T_{MAX}, unless otherwise noted. Typical values are at T_A = +25°C.)

PARAMETER	SYMBOL	CONDITIONS	MIN	TYP	MAX	UNITS
ADC						
Resolution		No missing codes	12			Bits
DSP-Mode Resolution		256 oversampling, dither enabled	16			Bits
Integral Nonlinearity	INL	Normal mode (Note 1)			±1	LSB ₁₂
Differential Nonlinearity	DNL	Normal mode (Note 1)			±1	LSB ₁₂
Offset Error		(Note 1)			±4	mV
Offset Drift				±1.5		µV/°C
Gain Error (Excluding Reference) (Note 1)		Gain = 1			±0.1	% FS
		Gain = 2, 4			±1.5	
		Gain = 8			±2.5	
Gain Temperature Coefficient		Excluding reference		±0.8		ppm/°C
Voltage Range		Unipolar mode, gain = 1, 2, 4, 8	0	+V _{REFADC} / Gain		V
		Bipolar mode, gain = 1, 2, 4, 8	-V _{REFADC} / (2 x Gain)	+V _{REFADC} / (2 x Gain)		
Absolute Input Voltage Range			AGND		AV _{DD}	V
Input Leakage Current into Analog Inputs		(Note 2)		±0.5	±1	nA
Input Capacitance		Gain = 1, 2		24		pF
		Gain = 4, 8		48		
Acquisition Time	t _{ACQ}	Gain = 1, 2	0.6			µs
		Gain = 4, 8	1.2			
Conversion Time	t _{CONV}	12 clocks	2.4			µs
Conversion Clock Frequency			0.1		5.0	MHz
ADC Supply Current (Note 3)		Normal operation mode, ADC converting at 234ksps		325		µA
		Fast power-down mode, ADC converting at 234ksps		210		
Aperture Delay	t _{AD}			30		ns

12-/16-Bit DASs with ADC, DACs, DPIOs, APIOs, Reference, Voltage Monitors, and Temp Sensor

ELECTRICAL CHARACTERISTICS (continued)

(DV_{DD} = 1.8V to 3.6V, AV_{DD} = 2.7V to 5.5V, V_{REFDAC} = V_{REFADC} = 2.5V, external reference; 10μF capacitor at REFADC and REFDAC; 0.01μF capacitor at REFADJ; T_A = T_{MIN} to T_{MAX}, unless otherwise noted. Typical values are at T_A = +25°C.)

PARAMETER	SYMBOL	CONDITIONS	MIN	TYP	MAX	UNITS
Aperture Jitter	t _{AJ}			50		ps
Sample Rate		Gain = 1, 2; DV _{DD} ≥ 2.7V, AV _{DD} ≥ 5.0V			312	ksps
		Gain = 4, 8; DV _{DD} ≥ 2.7V, AV _{DD} ≥ 5.0V			263	
		Gain = 1, 2			234	
		Gain = 4, 8			200	
Power-Supply Rejection	PSR	AV _{DD} = 2.7V to 5.5V, full-scale input		±0.06	±0.5	mV/V
Turn-On Time		Supply and reference have settled		1		μs
ADC DYNAMIC ACCURACY (10kHz sine wave, V_{IN} = 2.5Vp-p, f_{SAMPLE} = 234ksps, gain = 1)						
Signal-to-Noise Plus Distortion	SINAD			71		dB
Total Harmonic Distortion	THD	Up to the 5th harmonic		82		dB
Spurious-Free Dynamic Range	SFDR			84		dB
Channel-to-Channel Crosstalk				100		dB
Full-Power Bandwidth	FPBW	-3dB point		4		MHz
DAC (R_L = 5kΩ, C_L = 200pF, tested in unity gain, unless otherwise noted)						
Resolution			12			Bits
Differential Nonlinearity	DNL	Guaranteed monotonic (Note 4)			±1.0	LSB
Integral Nonlinearity	INL	(Note 4)		±1	±8	LSB
Offset Error		Code = 0x000 (tested at 0x032)		±2.5	±30	mV
Offset-Error Temperature Coefficient		Due to amplifier		±7		μV/°C
Gain Error		Code = 0xFFFF		0	±5	% FS
Gain-Error Temperature Coefficient		Excluding reference drift		±7		ppm/°C
Output Voltage Range		No load	AGND		AV _{DD}	V
Output Slew Rate		C _L = 200pF		0.5		V/μs
Output Settling Time		Code = 0x400 to 0xC00 (Note 2)		4	10	μs
FB_ Input Bias Current		(Note 2)		±0.1	1	nA
FB_ Switch Resistance					200	Ω
FB_ Switch Turn-On/-Off Time				40		ns
FB_ Switch Off Isolation		f = 10kHz		100		dB
FB_ Switch Charge Injection				1		pC
DAC-to-DAC Crosstalk				0.5		nV-s
Short-Circuit Current		Sink		13		mA
		Source		50		
DC Output Impedance		Code = 0x800		0.8		Ω
Power-Up Time		0.5 LSB settling to 0x800		5		μs
Power-Supply Rejection	PSR	AV _{DD} = 2.7V to 5.5V		±1		mV/V
Charge-Pump Output Feedthrough		Code = 0x800, buffer on, R _L = 5kΩ, C _L = 200pF		100		μVRMS

12-/16-Bit DASs with ADC, DACs, DPIOs, APIOs, Reference, Voltage Monitors, and Temp Sensor

ELECTRICAL CHARACTERISTICS (continued)

(DVDD = 1.8V to 3.6V, AVDD = 2.7V to 5.5V, VREFDAC = VREFADC = 2.5V, external reference; 10 μ F capacitor at REFADC and REFDAC; 0.01 μ F capacitor at REFADJ; TA = TMIN to TMAX, unless otherwise noted. Typical values are at TA = +25°C.)

PARAMETER	SYMBOL	CONDITIONS	MIN	TYP	MAX	UNITS
Power-Down Output Leakage Current					±100	nA
Supply Current per DAC		No load (Note 3)		70		μ A
INTERNAL REFERENCE (10μF capacitor at REFADC and REFDAC, 0.01μF capacitor at REFADJ)						
Output Voltage at REFADC and REFDAC		TA = +25°C, AREF<1:0> = DREF<1:0> = 01	1.225	1.250	1.275	V
		TA = +25°C, AREF<1:0> = DREF<1:0> = 10	2.007	2.048	2.089	
		TA = +25°C, AREF<1:0> = DREF<1:0> = 11	2.450	2.500	2.550	
Output-Voltage Temperature		(Note 2)		±10	±75	ppm/°C
REFADC and REFDAC Output Short-Circuit Current		Source		40		mA
		Sink		13		
REFADC and REFDAC Line Regulation				±100	±600	μ V/V
Load Regulation		ISOURCE = 0 μ A to 500 μ A, TA = +25°C			10	μ V/ μ A
		ISINK = 0 μ A to 80 μ A, TA = +25°C			10	
Long-Term Stability		TA = +25°C		±100		ppm/1000hrs
Turn-On Time		At REFADJ		2		ms
Turn-Off Time				100		ns
Reference Supply Current (Note 3)		Internal reference		445		μ A
		REFADC buffer		270		
		REFDAC buffer		270		
EXTERNAL REFERENCE AT REFADJ						
External Reference Input Voltage Range		AREF<1:0> = DREF<1:0> = 11	1.225V		AVDD - 0.1V	V
		AREF<1:0> = DREF<1:0> = 10		1.496V to AVDD - 0.1V		
		AREF<1:0> = DREF<1:0> = 01		2.450V to AVDD - 0.1V		
Input Resistance			50	75		k Ω
REFADC Buffer Gain		AREF<1:0> = 01		1		V/V
		AREF<1:0> = 10		0.8192		
		AREF<1:0> = 11		0.5		
REFDAC Buffer Gain		DREF<1:0> = 01		1		V/V
		DREF<1:0> = 10		0.8192		
		DREF<1:0> = 11		0.5		
Minimum Capacitive Bypass		REFADJ to AGND		10		nF

12-/16-Bit DASs with ADC, DACs, DPIOs, APIOs, Reference, Voltage Monitors, and Temp Sensor

ELECTRICAL CHARACTERISTICS (continued)

(DVDD = 1.8V to 3.6V, AVDD = 2.7V to 5.5V, VREFDAC = VREFADC = 2.5V, external reference; 10μF capacitor at REFADC and REFDAC; 0.01μF capacitor at REFADJ; TA = TMIN to TMAX, unless otherwise noted. Typical values are at TA = +25°C.)

PARAMETER	SYMBOL	CONDITIONS	MIN	TYP	MAX	UNITS
EXTERNAL REFERENCE AT REFADC						
External Reference Input Voltage Range			AGND		AVDD	V
REFADC Input Resistance			50	75		kΩ
REFADC Input Current		VREFADC = 2.5V, 300ksps		30	40	μA
Turn-On Time		REFADC buffer, CREFADC = 1μF		75		μs
Shutdown REFADC Input Current				0.01	1.0	μA
Minimum Capacitive Bypass		REFADC to AGND	10			μF
EXTERNAL REFERENCE AT REFDAC						
REFDAC Input Voltage Range			AGND		AVDD	V
REFDAC Input Resistance		MAX1329	64	90	180	kΩ
		MAX1330	128	180	360	
REFDAC Input Current		MAX1329, VREFDAC = 2.5V		28	86	μA
		MAX1330, VREFDAC = 2.5V		14	43	
Turn-On Time		REFDAC buffer		75		μs
Shutdown REFDAC Input Current				0.1	1	μA
Minimum Capacitive Bypass		REFDAC to AGND	10			μF
MULTIPLEXER						
Absolute Input Voltage Range			AGND		AVDD	V
Absolute Input Leakage Current		(AGND + 100mV) < VAIN_ < (AVDD - 100mV) (Note 2)		±0.01	±1	nA
Input Capacitance		ADC gain = 1, 2		24		pF
		ADC gain = 4, 8		48		
On Resistance				340		Ω
INTERNAL TEMPERATURE SENSOR						
Internal Sensor Measurement Error (Note 5)		TA = +25°C		±0.25		°C
		TA = -40°C to +85°C			±3	
External Sensor Measurement Error (Note 5)		TA = +25°C		±0.4		°C
		TA = 0°C to +70°C		±2		
		TA = -40°C to +85°C		±3		

12-/16-Bit DASs with ADC, DACs, DPIOs, APIOs, Reference, Voltage Monitors, and Temp Sensor

ELECTRICAL CHARACTERISTICS (continued)

(DV_{DD} = 1.8V to 3.6V, AV_{DD} = 2.7V to 5.5V, V_{REFDAC} = V_{REFADC} = 2.5V, external reference; 10μF capacitor at REFADC and REFDAC; 0.01μF capacitor at REFADJ; T_A = T_{MIN} to T_{MAX}, unless otherwise noted. Typical values are at T_A = +25°C.)

PARAMETER	SYMBOL	CONDITIONS	MIN	TYP	MAX	UNITS
Temperature Resolution		V _{REFADC} = 2.5V		1/8		°C/LSB
External-Diode Drive Ratio		I _{DRIVEMIN} = 4μA, I _{DRIVEMAX} = 68μA		17:1		
Temperature-Sensor Supply Current		Not including ADC current (Note 3)		100		μA
Temperature-Sensor Conversion Time		307 clocks per measurement, master clock = 5.00MHz		65		μs
CHARGE PUMP						
Input Voltage	DV _{DD}		1.8		3.6	V
No-Load Output Voltage	AV _{DD}	DV _{DD} = 1.8V to 3.0V, VM2CP<2:0> = 001	2.85	3.0	3.20	V
		DV _{DD} = 2.2V to 3.6V, VM2CP<2:0> = 010	3.75	4.0	4.30	
		DV _{DD} = 2.7V to 3.6V, VM2CP<2:0> = 011	4.80	5.0	5.40	
Output Current		Including internal current (Table 32)	25			mA
No-Load Supply Current		DV _{DD} = 2.7V, AV _{DD} = 4V, 39kHz clock		250		μA
Switching Frequency			39		78	kHz
Switch Turn-On/Off Time		Between DV _{DD} to AV _{DD} , charge pump off		40		ns
Switch Impedance		Shorts DV _{DD} to AV _{DD} , charge pump off		25	50	Ω
Efficiency		25mA load, DV _{DD} = 1.8V, AV _{DD} = 3.0V, 39kHz clock		80		%
DV_{DD} VOLTAGE MONITOR (VM1)						
Supply Voltage Range			1.0		3.6	V
Trip Threshold (DV _{DD} Falling)	V _{DTH}	VM1<1:0> = 0x, $\overline{RST1}$ input	1.80	1.865	1.93	V
		VM1<1:0> = x0, $\overline{RST2}$ input	2.65	2.750	2.90	
Hysteresis	V _{DHYS}	VM1<1:0> = 0x, $\overline{RST1}$ input		15		mV
		VM1<1:0> = x0, $\overline{RST2}$ input		22.5		
Reset Timeout Period		V _{DVDD} = V _{DTH} + V _{DHYS}		170		ms
Turn-On Time		DV _{DD} = 1.8V, enabled by VM1 <1:0>		2		ms
AV_{DD} VOLTAGE MONITOR (VM2)						
Supply Voltage Range			1.0		5.5	V
Trip Threshold (AV _{DD} Falling) (Note 6)	V _{A_{TH}}	VM2CP<1:0> = 01	2.53	2.775	2.975	V
		VM2CP<1:0> = 10	3.4	3.700	3.925	
		VM2CP<1:0> = 11	4.25	4.625	4.925	
Hysteresis	V _{A_{HYS}}	VM2CP<1:0> = 01		22.5		mV
		VM2CP<1:0> = 10		30		
		VM2CP<1:0> = 11		37.5		

12-/16-Bit DASs with ADC, DACs, DPIOs, APIOs, Reference, Voltage Monitors, and Temp Sensor

MAX1329/MAX1330

ELECTRICAL CHARACTERISTICS (continued)

(DVDD = 1.8V to 3.6V, AVDD = 2.7V to 5.5V, VREFDAC = VREFADC = 2.5V, external reference; 10μF capacitor at REFADC and REFDAC; 0.01μF capacitor at REFADJ; TA = TMIN to TMAX, unless otherwise noted. Typical values are at TA = +25°C.)

PARAMETER	SYMBOL	CONDITIONS	MIN	TYP	MAX	UNITS
Turn-On Time		AVDD = 2.7V, enabled by VM2CP<1:0>		2		ms
INTERNAL OSCILLATOR						
Clock Frequency		TA = TMIN to TMAX	3.5758	3.6864	3.7970	MHz
Turn-Off Delay		Using clock at CLKIO pin, ODLY = 1		1024		Clocks
Turn-On Time				200		ns
Supply Current		(Note 7)		120		μA
SWITCHES (SPDT)						
On Resistance		AVDD = 2.7V to 5.5V		140	200	Ω
		AVDD = 4.5V to 5.5V		90	120	
On-Resistance Match				15		Ω
On-Resistance Flatness		Over analog voltage range		12		Ω
Analog Voltage Range			AGND		AVDD	V
Turn-On/-Off Time		Break-before-make for SPDT configuration		50		ns
Leakage Current		AGND + 100mV < VSN_ < AVDD - 100mV (Note 2)		0.08	±1	nA
Off Isolation		f = 10kHz		100		dB
Charge Injection				1		pC
Input Capacitance				2		pF
OPERATIONAL AMPLIFIER (RL = 10kΩ, CL = 200pF)						
Input Bias Current		(Note 2)		0.3	±1	nA
Input Offset Voltage	VOS			2	±20	mV
Input Offset Drift	ΔVOS			±10		μV/°C
Common-Mode Rejection Ratio	CMRR	AGND + 100mV < VCM < AVDD - 100mV		75		dB
Phase Margin				60		degrees
Charge-Pump Output Feedthrough				100		μVp-p
Common-Mode Input Voltage Range			AGND		AVDD	V
Output Voltage Range		No load	AGND		AVDD	V
		10kΩ load	0.1		AVDD - 0.1	
		100kΩ load	0.1		AVDD - 0.1	
Gain Bandwidth Product				1		MHz
Slew Rate				0.5		V/μs
OSW_ Switch Resistance		AVDD = 2.7V to 5.5V		140	200	Ω
		AVDD = 4.5V to 5.5V		90	120	
OSW_ Switch Turn-On/-Off Time				50		ns

12-/16-Bit DASs with ADC, DACs, DPIOs, APIOs, Reference, Voltage Monitors, and Temp Sensor

ELECTRICAL CHARACTERISTICS (continued)

(DV_{DD} = 1.8V to 3.6V, AV_{DD} = 2.7V to 5.5V, V_{REFDAC} = V_{REFADC} = 2.5V, external reference; 10μF capacitor at REFADC and REFDAC; 0.01μF capacitor at REFADJ; T_A = T_{MIN} to T_{MAX}, unless otherwise noted. Typical values are at T_A = +25°C.)

PARAMETER	SYMBOL	CONDITIONS	MIN	TYP	MAX	UNITS
OSW_ Switch Charge Injection				1		pC
Input Noise Voltage Density		f _{IN_} = 1kHz		330		nV/√Hz
Input Noise Voltage		f _{IN_} = 0.1Hz to 10Hz		9		μV _{RMS}
Power-Down Output Leakage					±10	nA
Power-Supply Rejection Ratio		AV _{DD} = 2.7V to 5.5V	65	100		dB
Supply Current per Amplifier		(Note 3)		70		μA
Turn-On Time				5		μs
Short-Circuit Current		Source		50		mA
		Sink		13		
DC Output Impedance		A _v = 1V/V		0.2		Ω
DIGITAL INPUTS (DIN, SCLK, CS)						
Input High Voltage	V _{IH}		0.7 x DV _{DD}			V
Input Low Voltage	V _{IL}				0.3 x DV _{DD}	V
Input Hysteresis		DV _{DD} = 3V		200		mV
Input Leakage Current		V _{IN} = 0 or DV _{DD}		±0.01	±10	μA
DIGITAL OUTPUTS (DOUT, $\overline{\text{RST1}}$, $\overline{\text{RST2}}$)						
Output Low Voltage	V _{OL}	I _{SINK} = 1mA, DV _{DD} = 2.7V to 3.6V			0.4	V
		I _{SINK} = 200μA, DV _{DD} = 1.8V to 3.6V			0.4	
Output High Voltage	V _{OH}	I _{SOURCE} = 0.2mA, DV _{DD} = 2.7V to 3.6V	0.8 x DV _{DD}			V
		I _{SOURCE} = 100μA, DV _{DD} = 1.8V to 3.6V	0.8 x DV _{DD}			
DOUT Three-State Leakage				±0.01	±10	μA
DOUT Three-State Capacitance		(Note 2)			15	pF
$\overline{\text{RST1}}$, $\overline{\text{RST2}}$ Open-Drain Output Low Voltage		I _{SINK} = 1mA, DV _{DD} = 2.7V to 3.6V			0.4	V
		I _{SINK} = 200μA, DV _{DD} = 1.8V to 3.6V			0.4	
$\overline{\text{RST1}}$, $\overline{\text{RST2}}$ Open-Drain Output Leakage Current		(Note 2)		0.13	100	nA
DIGITAL I/O (DPIO1–DPIO4, CLKIO)						
Output Low Voltage		I _{SINK} = 2mA, DV _{DD} = 2.7V to 3.6V			0.4	V
		I _{SINK} = 1mA, DV _{DD} = 1.8V to 3.6V			0.4	
Output High Voltage		I _{SOURCE} = 2mA, DV _{DD} = 2.7V to 3.6V	0.8 x DV _{DD}			V
		I _{SOURCE} = 1mA, DV _{DD} = 1.8V to 3.6V	0.8 x DV _{DD}			

12-/16-Bit DASs with ADC, DACs, DPIOs, APIOs, Reference, Voltage Monitors, and Temp Sensor

ELECTRICAL CHARACTERISTICS (continued)

(DV_{DD} = 1.8V to 3.6V, AV_{DD} = 2.7V to 5.5V, V_{REFDAC} = V_{REFADC} = 2.5V, external reference; 10μF capacitor at REFADC and REFDAC; 0.01μF capacitor at REFADJ; T_A = T_{MIN} to T_{MAX}, unless otherwise noted. Typical values are at T_A = +25°C.)

PARAMETER	SYMBOL	CONDITIONS	MIN	TYP	MAX	UNITS
Input High Voltage			0.7 x DV _{DD}			V
Input Low Voltage		DPIO1–DPIO4			0.3 x DV _{DD}	V
		CLKIO			0.25 x DV _{DD}	
Input Hysteresis		DV _{DD} = 3V	110			mV
Three-State Leakage			±0.01		±1	μA
Three-State Capacitance		(Note 2)			15	pF
DPIO_ Pullup Resistance			0.5			MΩ
ANALOG I/O (APIO1–APIO4)						
Output Low Voltage		ISINK = 2mA, AV _{DD} = 2.7V to 5.5V			0.4	V
		ISINK = 1mA, AV _{DD} = 1.8V to 5.5V			0.4	
Output High Voltage		ISOURCE = 2mA, AV _{DD} = 2.7V to 5.5V	0.8 x AV _{DD}			V
		ISOURCE = 1mA, AV _{DD} = 1.8V to 5.5V	0.8 x AV _{DD}			
Input High Voltage		AV _{DD} = 2.7V to 5.5V	0.7 x AV _{DD}			V
		AV _{DD} = DV _{DD} = 1.8V to 3.6V	0.7 x AV _{DD}			
Input Low Voltage		AV _{DD} = 2.7V to 5.5V			0.3 x AV _{DD}	V
		AV _{DD} = DV _{DD} = 1.8V to 3.6V			0.3 x AV _{DD}	
Input Hysteresis		AV _{DD} = 3V	120			mV
		AV _{DD} = 5V	160			
Three-State Leakage			±0.01		±10	μA
Three-State Capacitance		(Note 2)			15	pF
Pullup Resistance			0.5			MΩ
POWER REQUIREMENTS						
DV _{DD} Supply Voltage Range			1.8		3.6	V
AV _{DD} Supply Voltage Range			2.7		5.5	V
Supply Current (Note 8)		Run (all on, except charge pump)		3.75	7.5	mA
		Sleep (1.8V or 2.7V monitor on)		1	2.5	μA
Shutdown Current		All off		0.5	1	μA

12-/16-Bit DASs with ADC, DACs, DPIOs, APIOs, Reference, Voltage Monitors, and Temp Sensor

TIMING CHARACTERISTICS

(DV_{DD} = 1.8V to 3.6V, AV_{DD} = 2.7V to 5.5V, T_A = T_{MIN} to T_{MAX}, unless otherwise noted.)

PARAMETER	SYMBOL	CONDITIONS	MIN	TYP	MAX	UNITS
SERIAL-INTERFACE TIMING PARAMETERS (DV_{DD} = 2.7V to 3.6V) (Figures 1 and 2)						
SCLK Operating Frequency	f _{OP}		0		20	MHz
SCLK Cycle Time	t _{CYC}		50			ns
DIN to SCLK Setup	t _{DS}		15			ns
DIN to SCLK Hold	t _{DH}		0			ns
SCLK Fall to Output Data Valid	t _{DO}				20	ns
$\overline{\text{CS}}$ Fall to Output Enable	t _{DV}				24	ns
$\overline{\text{CS}}$ Rise to Output Disable	t _{TR}				24	ns
$\overline{\text{CS}}$ to SCLK Rise Setup	t _{CSS}		15			ns
$\overline{\text{CS}}$ to SCLK Rise Hold	t _{CSH}		0			ns
SCLK Pulse-Width High	t _{CH}		20			ns
SCLK Pulse-Width Low	t _{CL}		20			ns
SERIAL-INTERFACE TIMING PARAMETERS (DV_{DD} = 1.8V to 3.6V) (Figures 1 and 2)						
SCLK Operating Frequency	f _{OP}		0		10	MHz
SCLK Cycle Time	t _{CYC}		100			ns
DIN to SCLK Setup	t _{DS}		30			ns
DIN to SCLK Hold	t _{DH}		0			ns
SCLK Fall to Output Data Valid	t _{DO}				40	ns
$\overline{\text{CS}}$ Fall to Output Enable	t _{DV}				48	ns
$\overline{\text{CS}}$ Rise to Output Disable	t _{TR}				48	ns
$\overline{\text{CS}}$ to SCLK Rise Setup	t _{CSS}		30			ns
$\overline{\text{CS}}$ to SCLK Rise Hold	t _{CSH}		0			ns
SCLK Pulse-Width High	t _{CH}		40			ns
SCLK Pulse-Width Low	t _{CL}		40			ns
DIGITAL PROGRAMMABLE I/O TIMING PARAMETERS (DPIO1–DPIO4, DV_{DD} = 2.7V to 3.6V, C_L = 20pF)						
SPI Write to DPIO Output Valid	t _{SD}	From last SCLK rising edge			50	ns
DPIO Rise/Fall Input to Interrupt Asserted Delay	t _{DI}	Interrupt programmed on $\overline{\text{RST1}}$ and/or $\overline{\text{RST2}}$, corresponding status bits unmasked			55	ns
DPIO Input to Analog Block Delay	t _{DA}	When controlling ADC, DACs, or switches		40		ns
DIGITAL PROGRAMMABLE I/O TIMING PARAMETERS (DPIO1–DPIO4, DV_{DD} = 1.8V to 3.6V, C_L = 20pF)						
SPI Write to DPIO Output Valid	t _{SD}	From last SCLK rising edge			100	ns
DPIO Rise/Fall Input to Interrupt Asserted Delay	t _{DI}	Interrupt programmed on $\overline{\text{RST1}}$ and/or $\overline{\text{RST2}}$, corresponding status bits unmasked			150	ns
DPIO Input to Analog Block Delay	t _{DA}	When controlling ADC, DACs, or switches		50		ns
ANALOG PROGRAMMABLE I/O TIMING PARAMETERS (APIO1–APIO4, DV_{DD} = 2.7V to 3.6V, AV_{DD} = 2.7V to 5.5V, C_L = 20pF)						
SPI Write to APIO Output Valid	t _{SD}	From last SCLK rising edge			50	ns
APIO Rise/Fall Input to Interrupt Asserted Delay	t _{DI}	Interrupt programmed on $\overline{\text{RST1}}$ and/or $\overline{\text{RST2}}$, corresponding status bits unmasked			50	ns
$\overline{\text{CS}}$ to APIO4 Propagation Delay	t _{DCA}	AP4MD<1:0> = 11			35	ns

12-/16-Bit DASs with ADC, DACs, DPIOs, APIOs, Reference, Voltage Monitors, and Temp Sensor

TIMING CHARACTERISTICS (continued)

(DV_{DD} = 1.8V to 3.6V, AV_{DD} = 2.7V to 5.5V, T_A = T_{MIN} to T_{MAX}, unless otherwise noted.)

PARAMETER	SYMBOL	CONDITIONS	MIN	TYP	MAX	UNITS
SCLK to APIO3 Propagation Delay	t _{DSA}	AP3MD<1:0> = 11, \overline{CS} is high			30	ns
DIN to APIO2 Propagation Delay	t _{DDA}	AP2MD<1:0> = 11, \overline{CS} is high			25	ns
APIO1 to DOUT Propagation Delay	t _{DAD}	AP1MD<1:0> = 11, \overline{CS} is high			20	ns
SPI-Mode Propagation Delay Matching	t _{DM}	Among APIO4, APIO3, APIO2, and APIO1			±10	ns
ANALOG PROGRAMMABLE I/O TIMING PARAMETERS (APIO1–APIO4, DV_{DD} = 1.8V to 3.6V, AV_{DD} = 2.7V to 5.5V, C_L = 20pF)						
SPI Write to APIO Output Valid	t _{SD}	From last SCLK rising edge			100	ns
APIO Rise/Fall Input to Interrupt Asserted Delay	t _{DI}	Interrupt programmed on $\overline{RST1}$ and/or $\overline{RST2}$, corresponding status bits unmasked			175	ns
\overline{CS} to APIO4 Propagation Delay	t _{DCA}	AP4MD<1:0> = 11			60	ns
SCLK to APIO3 Propagation Delay	t _{DSA}	AP3MD<1:0> = 11, \overline{CS} is high			50	ns
DIN to APIO2 Propagation Delay	t _{DDA}	AP2MD<1:0> = 11, \overline{CS} is high			50	ns
APIO1 to DOUT Propagation Delay	t _{DAD}	AP1MD<1:0> = 11, \overline{CS} is high			80	ns
SPI-Mode Propagation Delay Matching	t _{DM}	Among APIO4, APIO3, APIO2, and APIO1			±30	ns

Note 1: ADC INL and DNL, offset, and gain are tested at DV_{DD} = 1.8V, AV_{DD} = 2.7V, f_{SAMPLE} = 234ksps to guarantee performance at f_{SAMPLE} = 312ksps, DV_{DD} ≥ 2.7V and AV_{DD} ≥ 5.0V.

Note 2: Guaranteed by design. Not production tested.

Note 3: AV_{DD} supply current contribution for this module.

Note 4: DNL and INL are measured between code 115 and 4095.

Note 5: Temperature sensor accuracy is tested using a 2.5084V reference applied to REFADJ.

Note 6: The maximum trip levels for the AV_{DD} monitor are 5% below the typical charge-pump output value. The charge-pump output voltage and the trip thresholds track to prevent tripping at -5% below the typical charge-pump output value.

Note 7: DV_{DD} supply current contribution for this module.

Note 8: The normal operation and sleep mode supply currents are measured with no load on DOUT, SCLK idle, and all digital inputs at DGND or DV_{DD}. CLKIO runs in normal mode operation and idle in sleep mode.

12-/16-Bit DASs with ADC, DACs, DPIOs, APIOs, Reference, Voltage Monitors, and Temp Sensor

Typical Operating Characteristics

($AV_{DD} = 5.0V$, $V_{REFADC} = V_{REFDAC} = 2.5V$ for $DV_{DD} = 3.0V$; $T_A = +25^\circ C$, unless otherwise noted.)

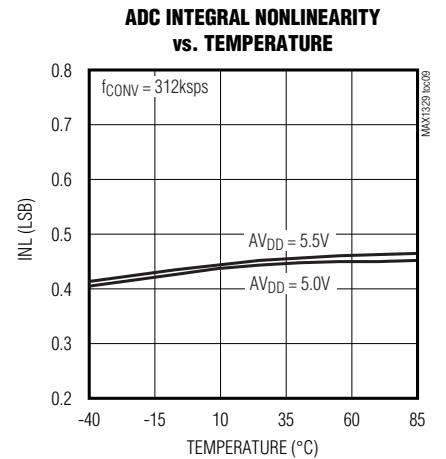
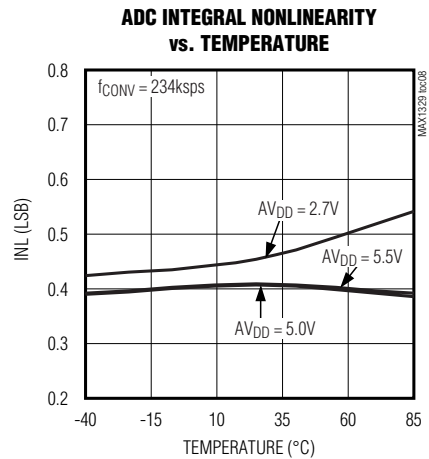
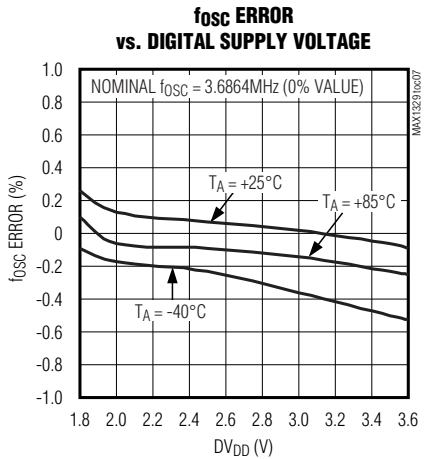
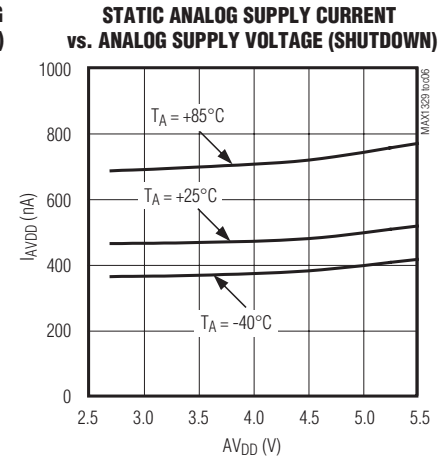
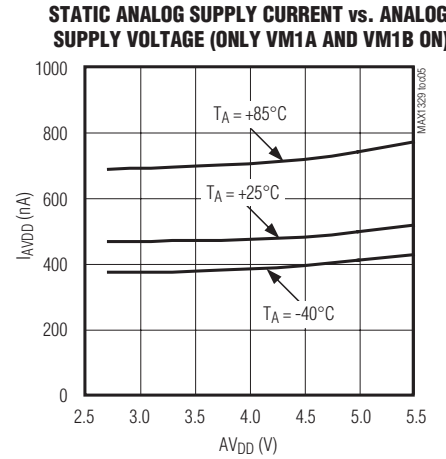
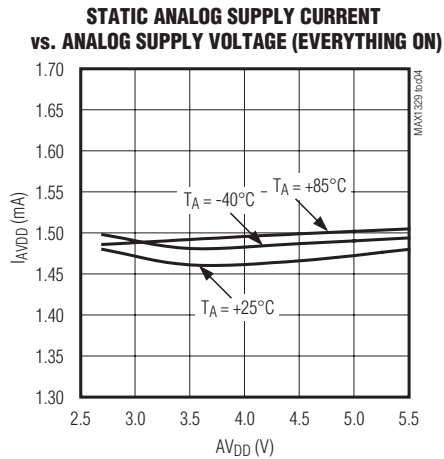
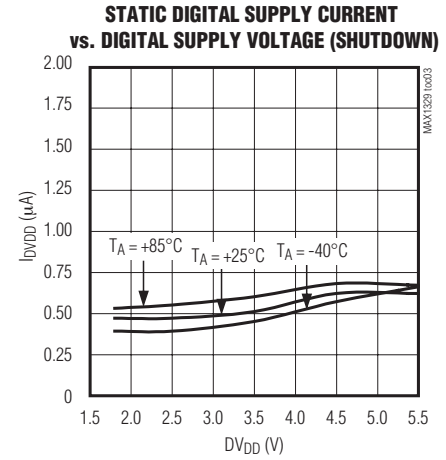
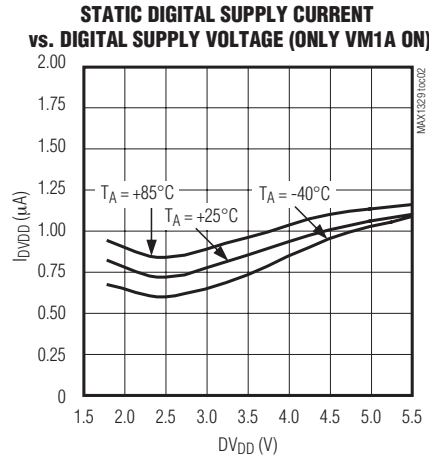
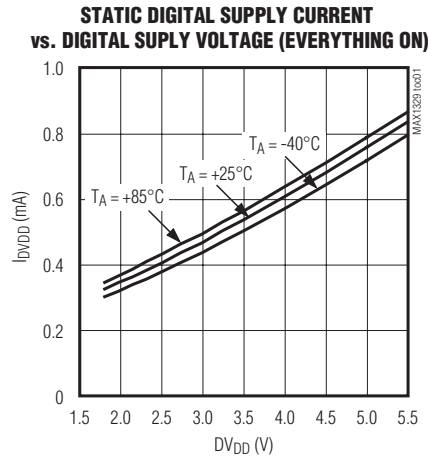

12-/16-Bit DASs with ADC, DACs, DPIOs, APIOs, Reference, Voltage Monitors, and Temp Sensor

MAX1329/MAX1330

Typical Operating Characteristics (continued)

($AV_{DD} = 5.0V$, $V_{REFADC} = V_{REFDAC} = 2.5V$ for $DV_{DD} = 3.0V$; $T_A = +25^\circ C$, unless otherwise noted.)

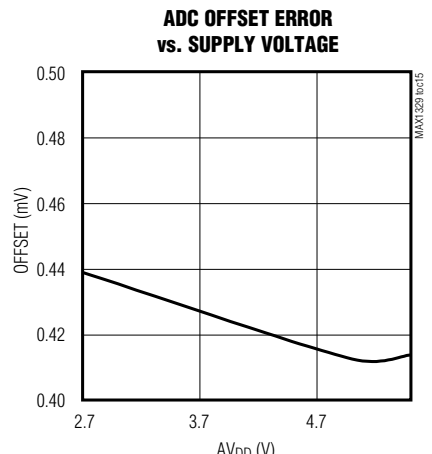
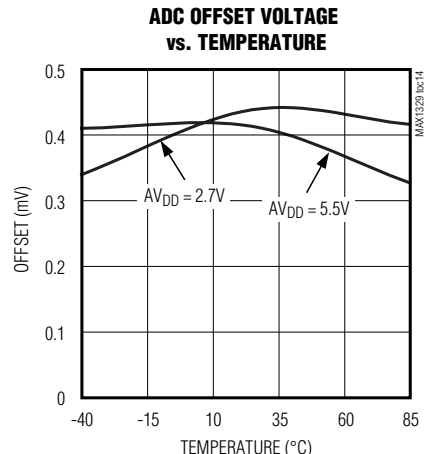
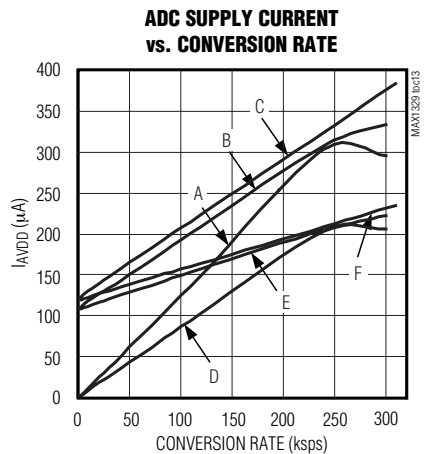
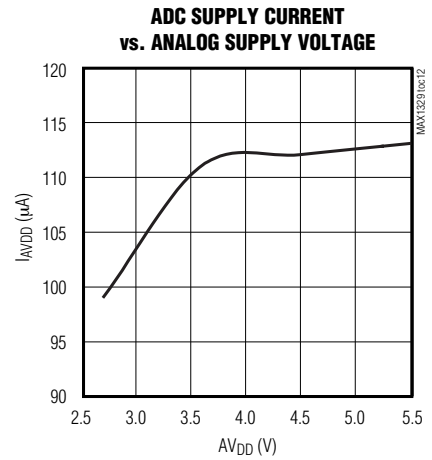
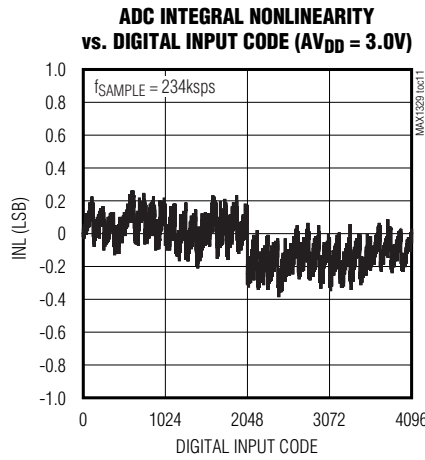
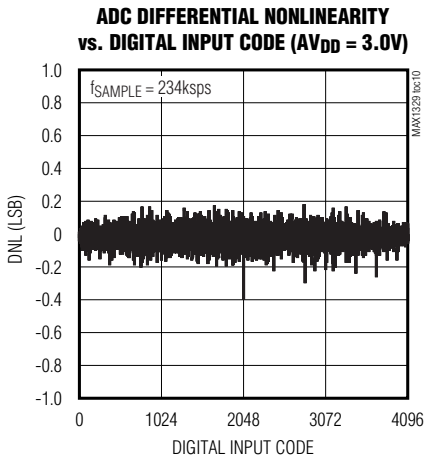

A = FAST POWER-DOWN B = NORMAL MODE C = BURST MODE
 $AV_{DD} = 5V$, $V_{REFDAC} = 2.5V$ $AV_{DD} = 5V$, $V_{REFDAC} = 2.5V$ $AV_{DD} = 5V$, $V_{REFDAC} = 2.5V$
D = FAST POWER-DOWN E = NORMAL MODE F = BURST MODE
 $AV_{DD} = 3V$, $V_{REFADC} = 1.25V$ $AV_{DD} = 3V$, $V_{REFADC} = 1.25V$ $AV_{DD} = 3V$, $V_{REFADC} = 1.25V$

12-/16-Bit DASs with ADC, DACs, DPIOs, APIOs, Reference, Voltage Monitors, and Temp Sensor

Typical Operating Characteristics (continued)

($AV_{DD} = 5.0V$, $V_{REFADC} = V_{REFDAC} = 2.5V$ for $DV_{DD} = 3.0V$; $T_A = +25^\circ C$, unless otherwise noted.)

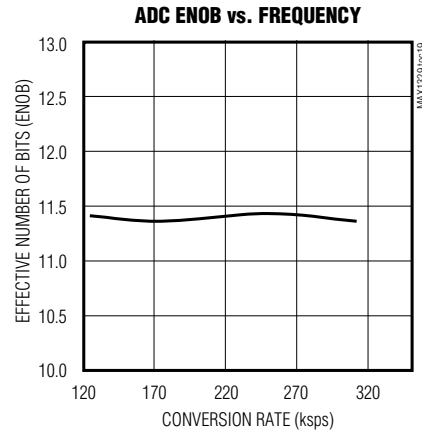
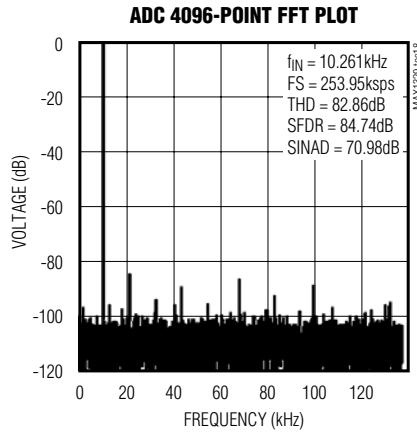
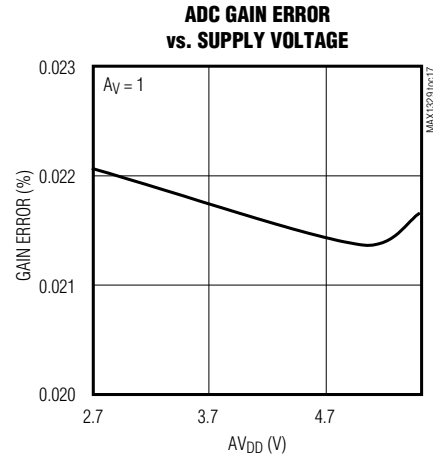
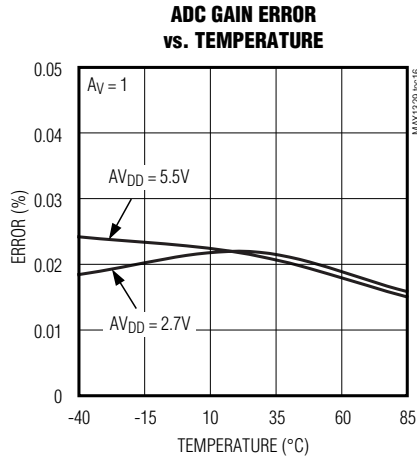

12-/16-Bit DASs with ADC, DACs, DPIOs, APIOs, Reference, Voltage Monitors, and Temp Sensor

Typical Operating Characteristics (continued)

($V_{DD} = 5.0V$, $V_{REFADC} = V_{REFDAC} = 2.5V$ for $DV_{DD} = 3.0V$; $T_A = +25^\circ C$, unless otherwise noted.)

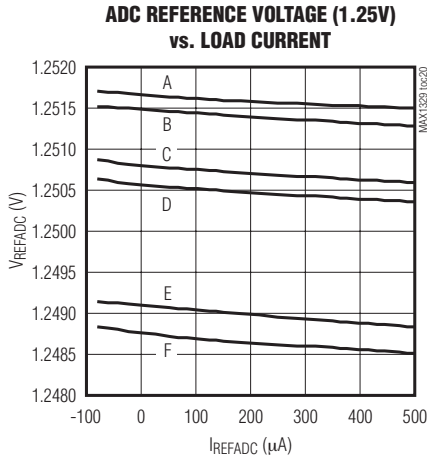

A: $T_A = -40^\circ C$, $AV_{DD} = 5V$, $DV_{DD} = 3V$ D: $T_A = +25^\circ C$, $AV_{DD} = 3V$, $DV_{DD} = 2V$
 B: $T_A = -40^\circ C$, $AV_{DD} = 3V$, $DV_{DD} = 2V$ E: $T_A = +85^\circ C$, $AV_{DD} = 5V$, $DV_{DD} = 3V$
 C: $T_A = +25^\circ C$, $AV_{DD} = 5V$, $DV_{DD} = 3V$ F: $T_A = +85^\circ C$, $AV_{DD} = 3V$, $DV_{DD} = 2V$

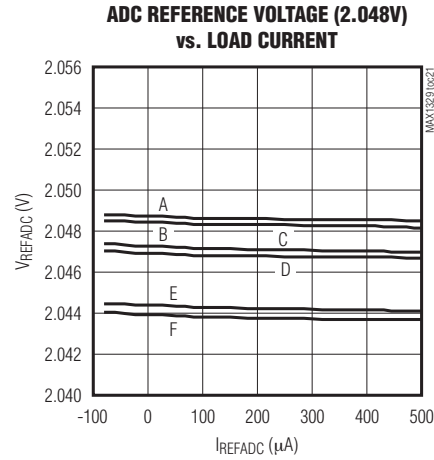

A: $T_A = -40^\circ C$, $AV_{DD} = 5V$, $DV_{DD} = 3V$ D: $T_A = +25^\circ C$, $AV_{DD} = 3V$, $DV_{DD} = 2V$
 B: $T_A = -40^\circ C$, $AV_{DD} = 3V$, $DV_{DD} = 2V$ E: $T_A = +85^\circ C$, $AV_{DD} = 5V$, $DV_{DD} = 3V$
 C: $T_A = +25^\circ C$, $AV_{DD} = 5V$, $DV_{DD} = 3V$ F: $T_A = +85^\circ C$, $AV_{DD} = 3V$, $DV_{DD} = 2V$

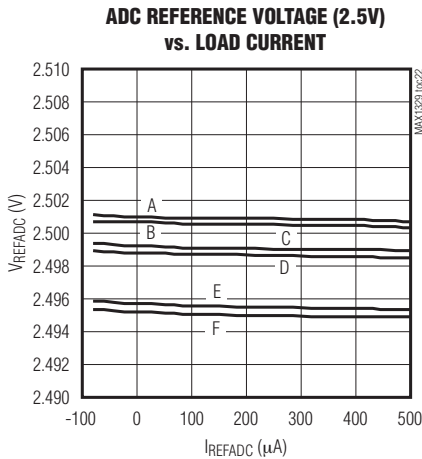

A: $T_A = -40^\circ C$, $AV_{DD} = 5V$, $DV_{DD} = 3V$ D: $T_A = +25^\circ C$, $AV_{DD} = 3V$, $DV_{DD} = 2V$
 B: $T_A = -40^\circ C$, $AV_{DD} = 3V$, $DV_{DD} = 2V$ E: $T_A = +85^\circ C$, $AV_{DD} = 5V$, $DV_{DD} = 3V$
 C: $T_A = +25^\circ C$, $AV_{DD} = 5V$, $DV_{DD} = 3V$ F: $T_A = +85^\circ C$, $AV_{DD} = 3V$, $DV_{DD} = 2V$

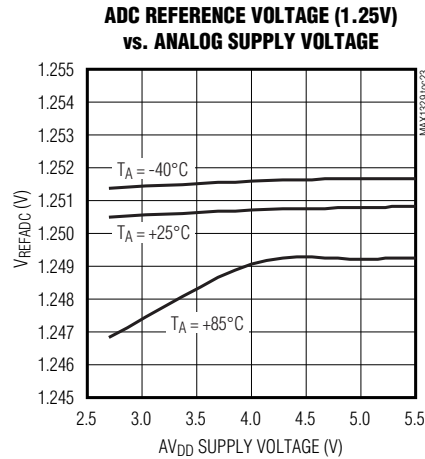

12-/16-Bit DASs with ADC, DACs, DPIOs, APIOs, Reference, Voltage Monitors, and Temp Sensor

Typical Operating Characteristics (continued)

($V_{DD} = 5.0V$, $V_{REFADC} = V_{REFDAC} = 2.5V$ for $DV_{DD} = 3.0V$; $T_A = +25^\circ C$, unless otherwise noted.)

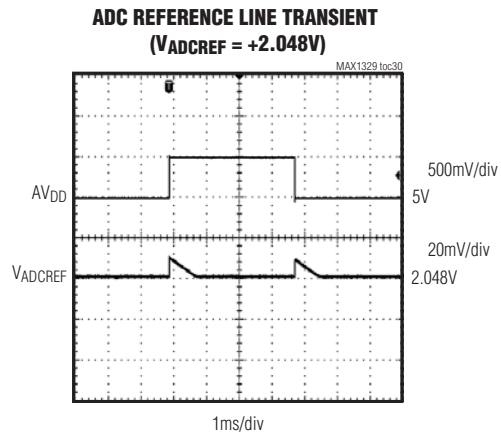
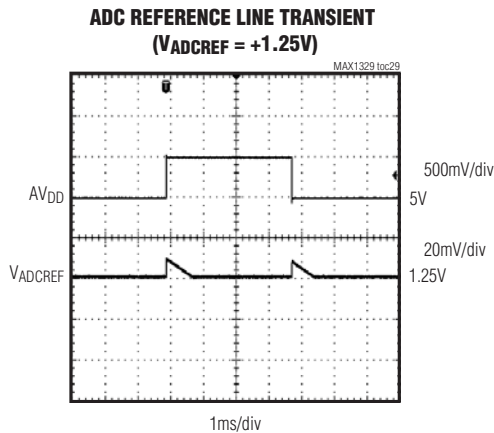
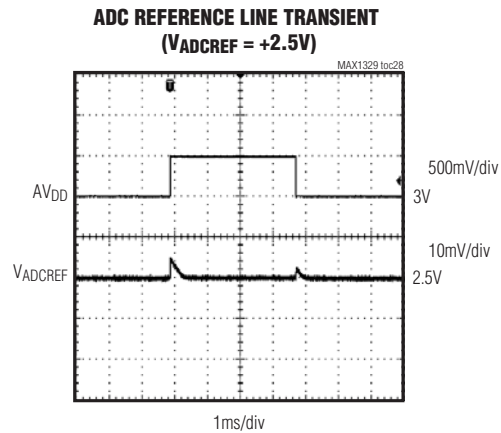
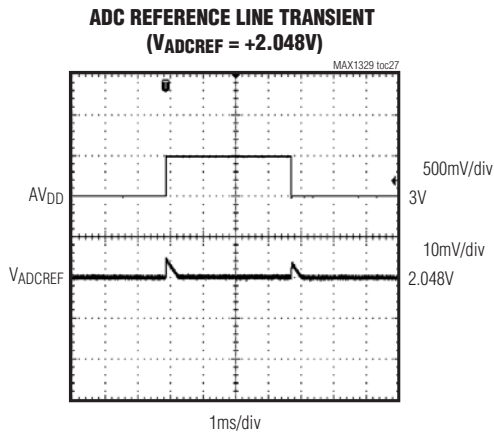
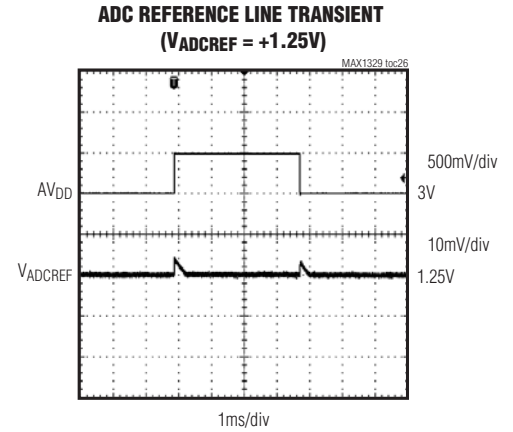
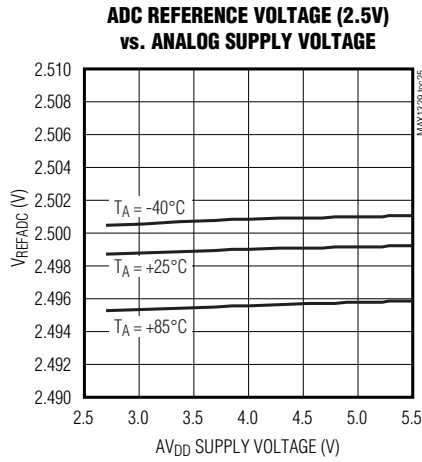
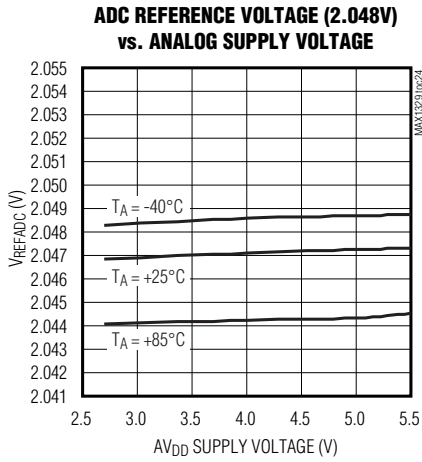

12-/16-Bit DASs with ADC, DACs, DPIOs, APIOs, Reference, Voltage Monitors, and Temp Sensor

Typical Operating Characteristics (continued)

($AV_{DD} = 5.0V$, $V_{REFADC} = V_{REFDAC} = 2.5V$ for $DV_{DD} = 3.0V$; $T_A = +25^\circ C$, unless otherwise noted.)

ADC REFERENCE LINE TRANSIENT
($V_{ADCREf} = +2.5V$)

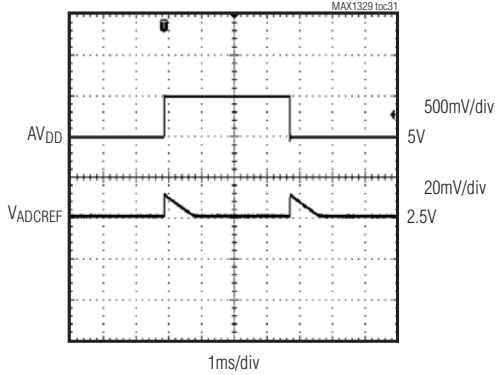

ADC REFERENCE SUPPLY CURRENT vs. ANALOG SUPPLY VOLTAGE

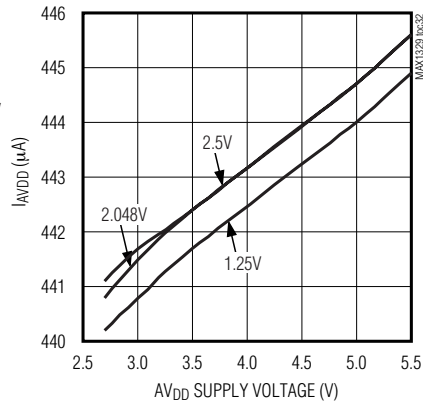

ADC REFERENCE TURN-ON TIME vs. ANALOG SUPPLY VOLTAGE

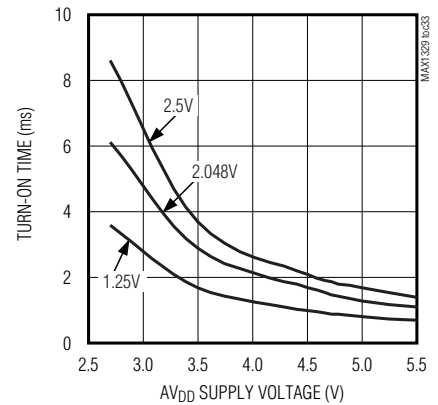

DAC INTEGRAL NONLINEARITY vs. DIGITAL INPUT CODE (AV_{DD} = 3V)

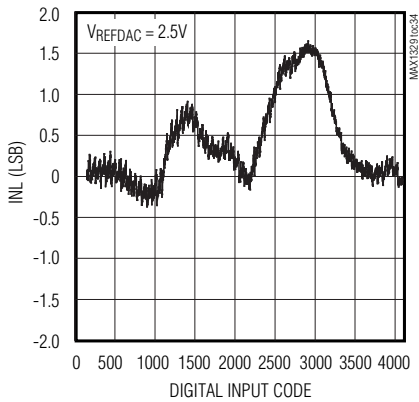

DAC INTEGRAL NONLINEARITY vs. DIGITAL INPUT CODE (AV_{DD} = 5V)

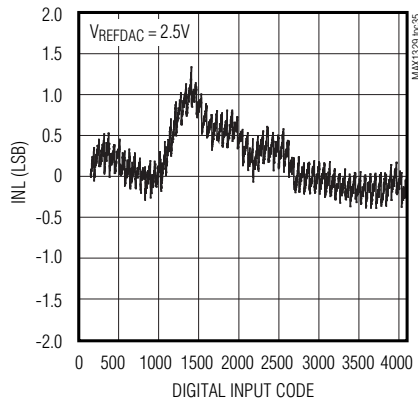

DAC DIFFERENTIAL NONLINEARITY vs. DIGITAL INPUT CODE (AV_{DD} = 3V)

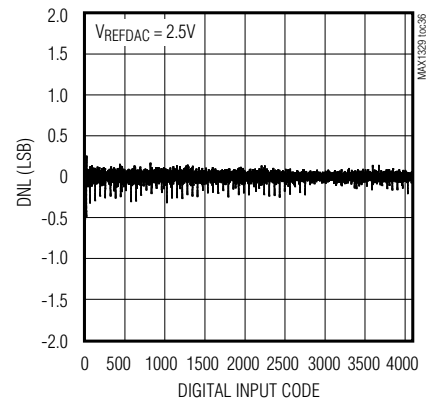

DAC DIFFERENTIAL NONLINEARITY vs. DIGITAL INPUT CODE (AV_{DD} = 5V)

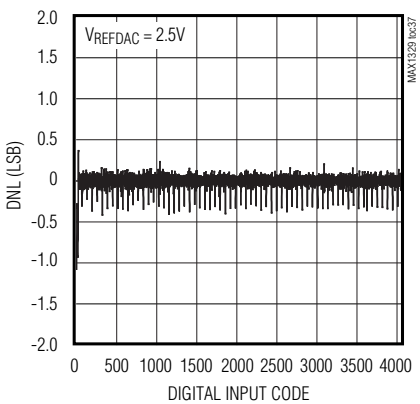

DAC SUPPLY CURRENT vs. ANALOG SUPPLY VOLTAGE

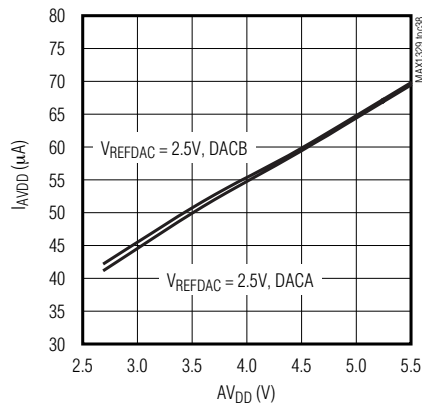

DAC OFFSET VOLTAGE vs. TEMPERATURE

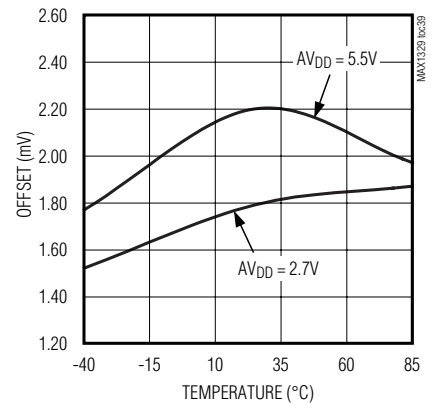

12-/16-Bit DASs with ADC, DACs, DPIOs, APIOs, Reference, Voltage Monitors, and Temp Sensor

Typical Operating Characteristics (continued)

($A_{VDD} = 5.0V$, $V_{REFADC} = V_{REFDAC} = 2.5V$ for $DV_{DD} = 3.0V$; $T_A = +25^\circ C$, unless otherwise noted.)

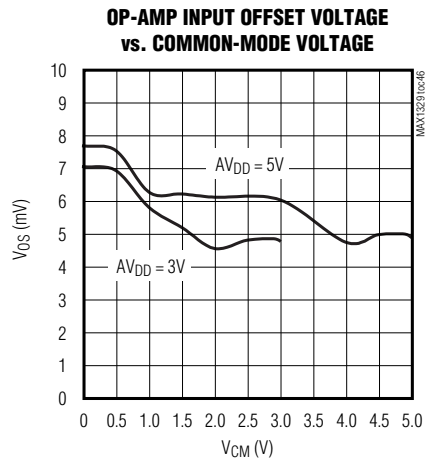
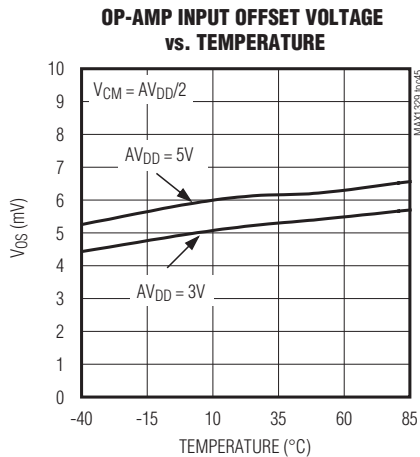
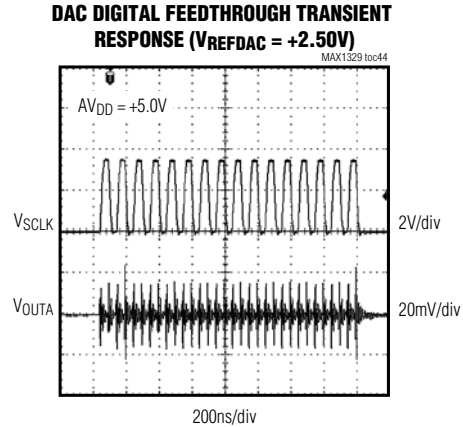
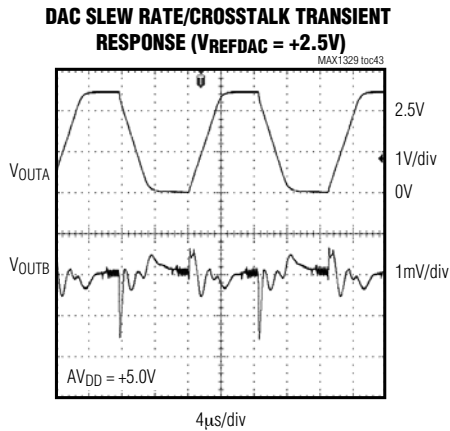
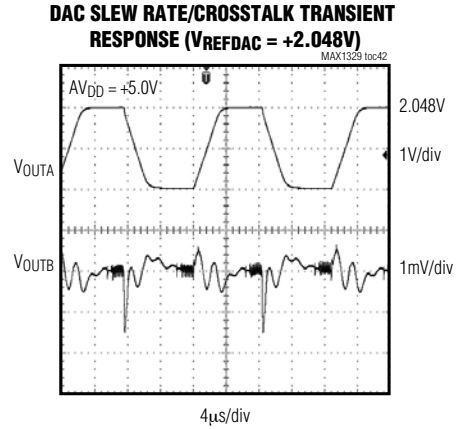
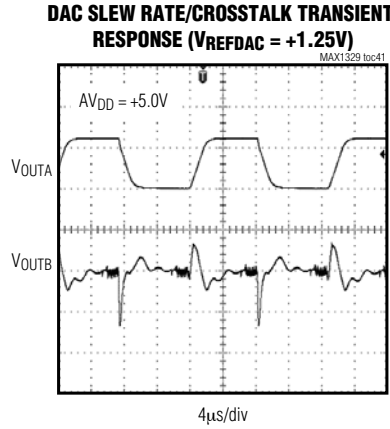
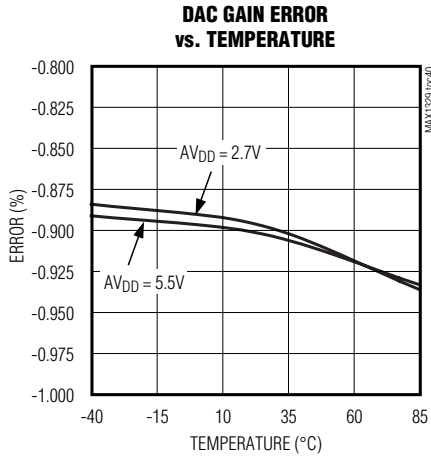

12-/16-Bit DASs with ADC, DACs, DPIOs, APIOs, Reference, Voltage Monitors, and Temp Sensor

MAX1329/MAX1330

Typical Operating Characteristics (continued)

($AV_{DD} = 5.0V$, $V_{REFADC} = V_{REFDAC} = 2.5V$ for $DV_{DD} = 3.0V$; $T_A = +25^\circ C$, unless otherwise noted.)

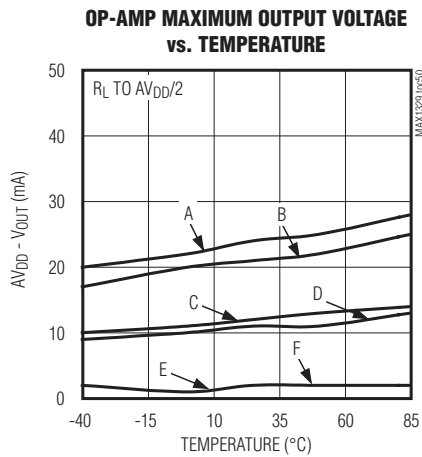
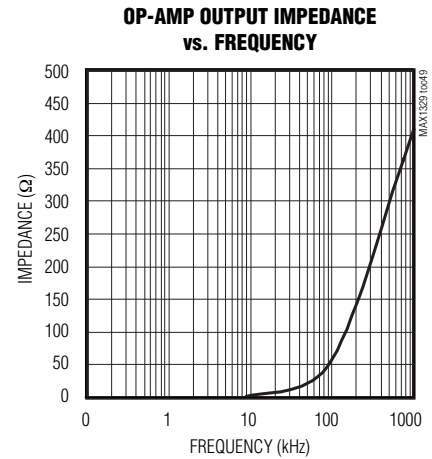
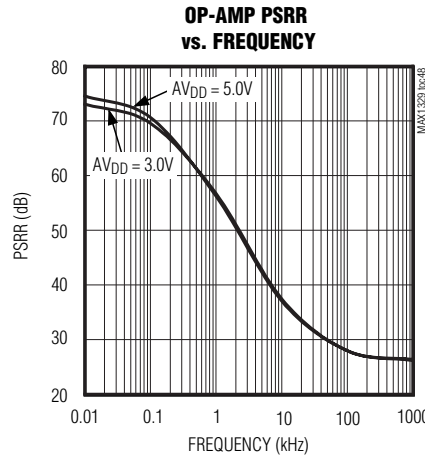
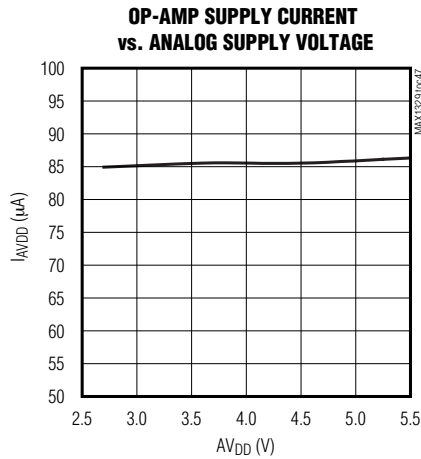

A: = $R_L = 5k\Omega$, $AV_{DD} = 5V$, $DV_{DD} = 3V$ B: = $R_L = 5k\Omega$, $AV_{DD} = 3V$, $DV_{DD} = 2V$
 C: = $R_L = 10k\Omega$, $AV_{DD} = 5V$, $DV_{DD} = 3V$ D: = $R_L = 10k\Omega$, $AV_{DD} = 3V$, $DV_{DD} = 2V$
 E: = $R_L = 100k\Omega$, $AV_{DD} = 5V$, $DV_{DD} = 3V$ F: = $R_L = 100k\Omega$, $AV_{DD} = 3V$, $DV_{DD} = 2V$

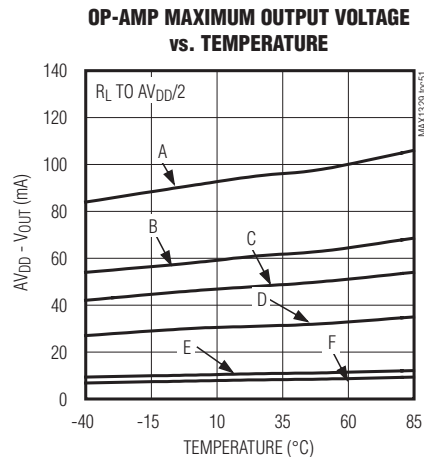

A: = $R_L = 5k\Omega$, $AV_{DD} = 5V$, $DV_{DD} = 3V$ B: = $R_L = 5k\Omega$, $AV_{DD} = 3V$, $DV_{DD} = 2V$
 C: = $R_L = 10k\Omega$, $AV_{DD} = 5V$, $DV_{DD} = 3V$ D: = $R_L = 10k\Omega$, $AV_{DD} = 3V$, $DV_{DD} = 2V$
 E: = $R_L = 100k\Omega$, $AV_{DD} = 5V$, $DV_{DD} = 3V$ F: = $R_L = 100k\Omega$, $AV_{DD} = 3V$, $DV_{DD} = 2V$

12-/16-Bit DASs with ADC, DACs, DPIOs, APIOs, Reference, Voltage Monitors, and Temp Sensor

Typical Operating Characteristics (continued)

($AV_{DD} = 5.0V$, $V_{REFADC} = V_{REFDAC} = 2.5V$ for $DV_{DD} = 3.0V$; $T_A = +25^\circ C$, unless otherwise noted.)

OP-AMP GAIN AND PHASE vs. FREQUENCY

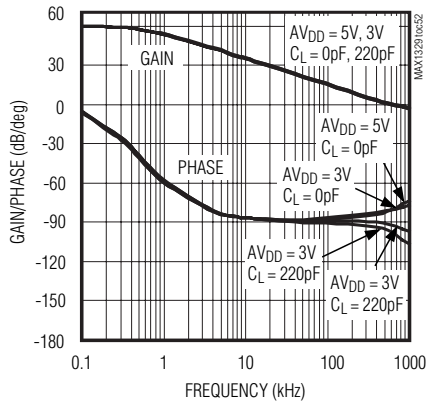

ANALOG SWITCH ON-RESISTANCE vs. COM VOLTAGE (AV_{DD} = 3V)

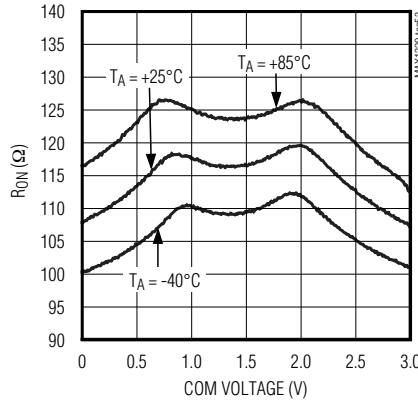

ANALOG SWITCH ON-RESISTANCE vs. COM VOLTAGE (AV_{DD} = 5V)

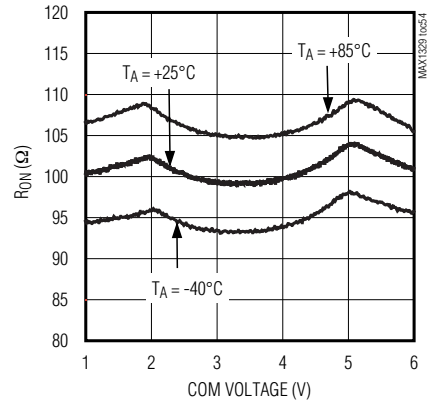

ANALOG SWITCH TURN-ON/OFF TIME vs. ANALOG SUPPLY VOLTAGE

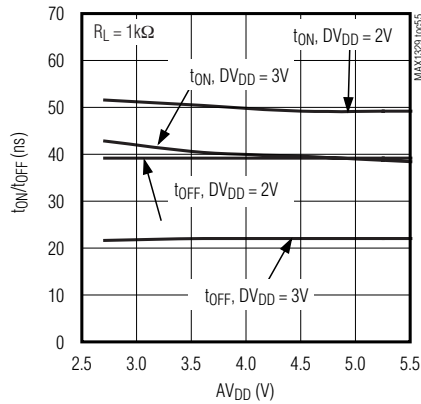

ANALOG SWITCH TURN-ON/OFF TIME vs. TEMPERATURE

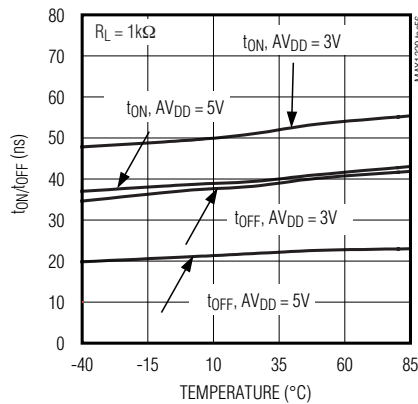

ANALOG SWITCH LEAKAGE CURRENT vs. TEMPERATURE

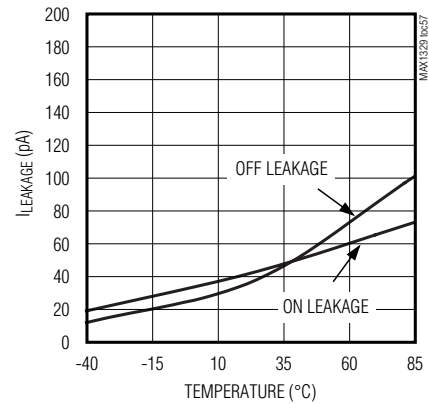

ANALOG SWITCH ON-RESPONSE vs. FREQUENCY

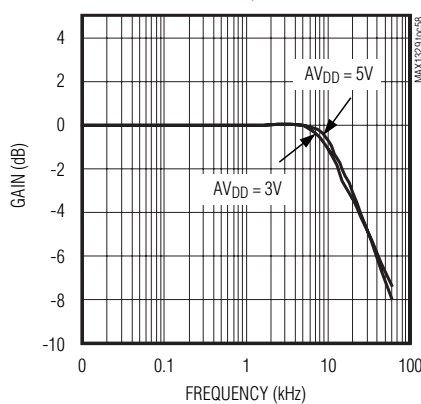

ANALOG SWITCH CROSSTALK AND OFF ISOLATION vs. FREQUENCY (AV_{DD} = 3V)

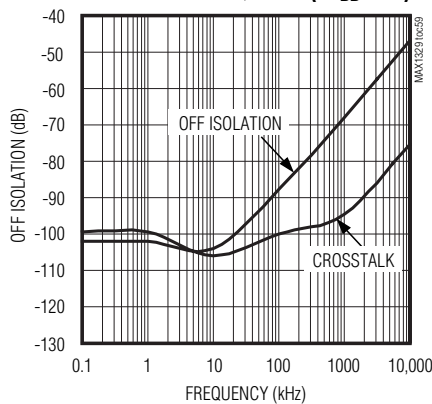

ANALOG SWITCH CROSSTALK AND OFF ISOLATION vs. FREQUENCY (AV_{DD} = 5V)

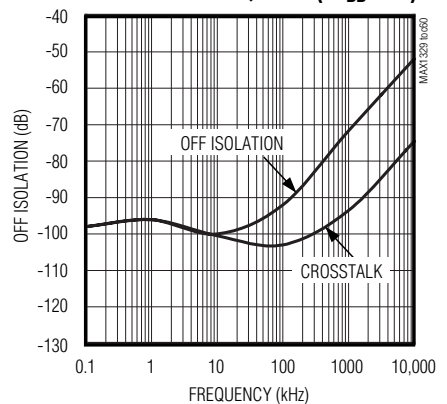

12-/16-Bit DASs with ADC, DACs, DPIOs, APIOs, Reference, Voltage Monitors, and Temp Sensor

MAX1329/MAX1330

Typical Operating Characteristics (continued)

($V_{DD} = 5.0V$, $V_{REFADC} = V_{REFDAC} = 2.5V$ for $DV_{DD} = 3.0V$; $T_A = +25^\circ C$, unless otherwise noted.)

TEMPERATURE-SENSOR ACCURACY vs. TEMPERATURE

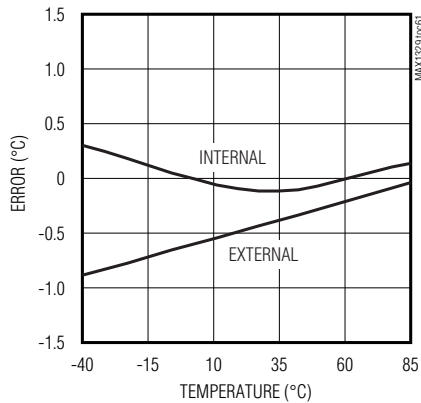

TEMPERATURE-SENSOR THERMAL STEP RESPONSE (+25°C TO +85°C)

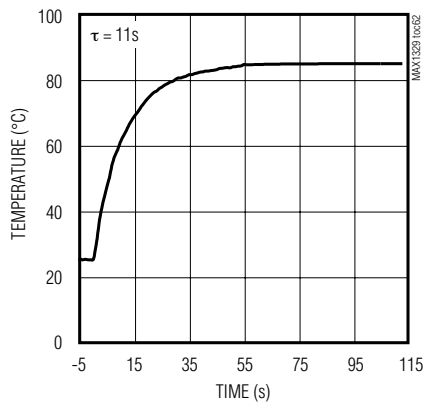

INTERNAL TEMPERATURE-SENSOR SUPPLY CURRENT vs. SUPPLY VOLTAGE

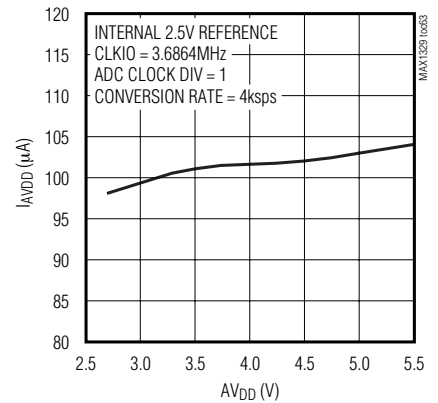

CHARGE-PUMP EFFICIENCY vs. OUTPUT CURRENT (AVDD = 3V)

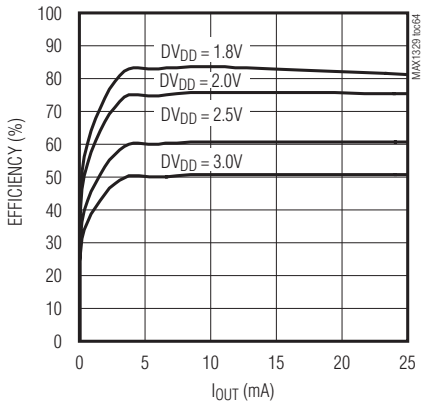

CHARGE-PUMP EFFICIENCY vs. OUTPUT CURRENT (AVDD = 4V)

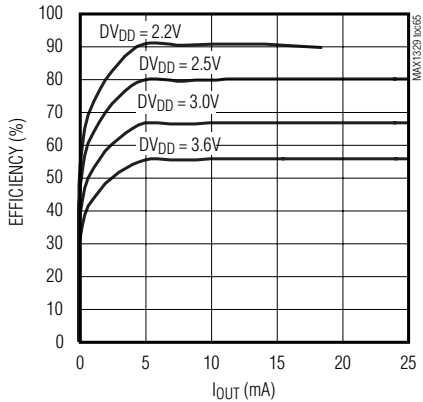

CHARGE-PUMP EFFICIENCY vs. OUTPUT CURRENT (AVDD = 5V)

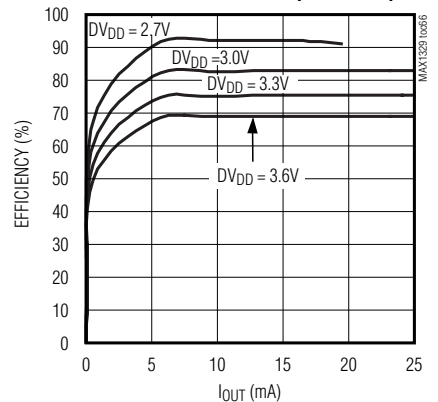

CHARGE-PUMP OUTPUT VOLTAGE vs. OUTPUT CURRENT (AVDD = 3V)

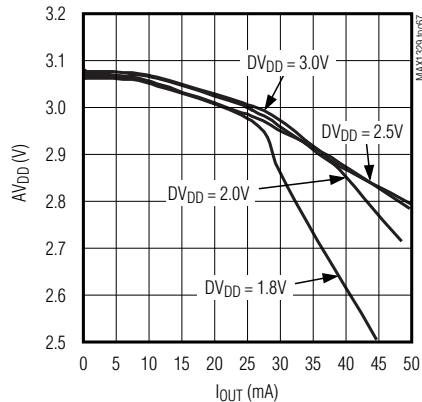

CHARGE-PUMP OUTPUT VOLTAGE vs. OUTPUT CURRENT (AVDD = 4V)

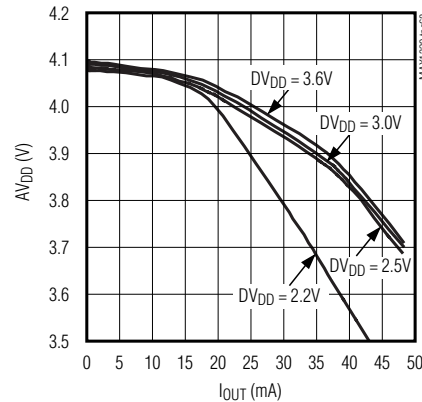

12-/16-Bit DASs with ADC, DACs, DPIOs, APIOs, Reference, Voltage Monitors, and Temp Sensor

Typical Operating Characteristics (continued)

($AV_{DD} = 5.0V$, $V_{REFADC} = V_{REFDAC} = 2.5V$ for $DV_{DD} = 3.0V$; $T_A = +25^\circ C$, unless otherwise noted.)

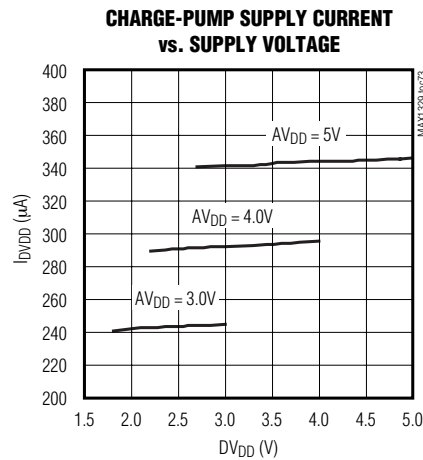
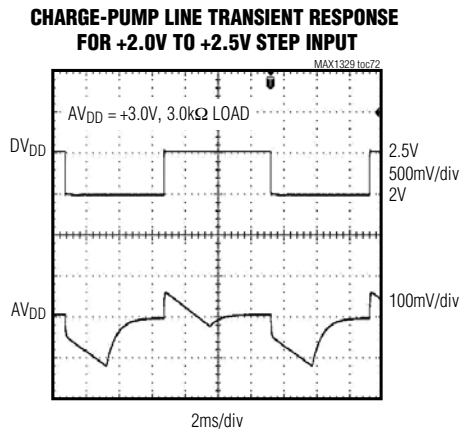
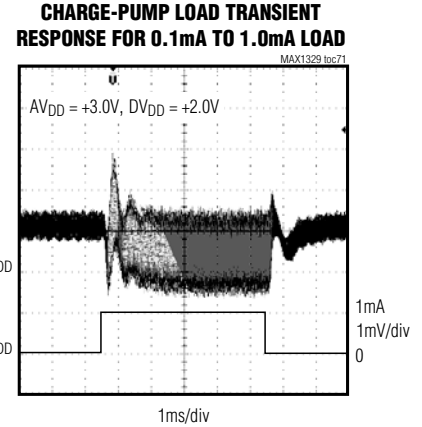
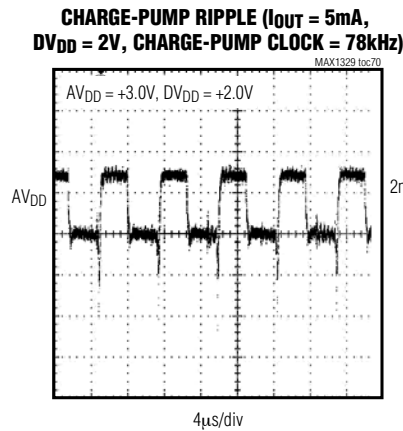
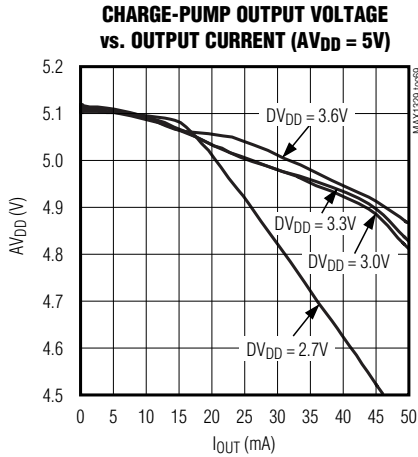

12-/16-Bit DASs with ADC, DACs, DPIOs, APIOs, Reference, Voltage Monitors, and Temp Sensor

Pin Description

MAX1329/MAX1330

PIN		NAME	FUNCTION
MAX1329	MAX1330		
1	1	DPIO1	Digital Programmable Input/Output 1
2	2	DPIO2	Digital Programmable Input/Output 2
3	3	DPIO3	Digital Programmable Input/Output 3
4	4	DPIO4	Digital Programmable Input/Output 4
5	5	DOUT	Serial-Data Output. DOUT outputs serial data from the data register. DOUT changes on the falling edge of SCLK and is valid on the rising edge of SCLK. When \overline{CS} is high, DOUT is high impedance, unless APIO1 is programmed for SPI mode.
6	6	SCLK	Serial-Clock Input. Apply an external serial clock to transfer data to and from the device. When \overline{CS} is high, SCLK is inactive unless APIO3 is configured for SPI mode. Then the input on SCLK is level-shifted and output at APIO3.
7	7	DIN	Serial-Data Input. Data on DIN is clocked in on the rising edge of SCLK when \overline{CS} is low. When \overline{CS} is high, DIN is inactive unless APIO2 is configured for SPI mode. Then the input on DIN is level-shifted and output at APIO2.
8	8	\overline{CS}	Active-Low Chip-Select Input. Drive \overline{CS} low to transfer data to and from the device. When \overline{CS} is high and APIO4 is configured for SPI mode, APIO4 is low.
9	9	$\overline{RST1}$	Open-Drain Reset Output 1. $\overline{RST1}$ remains low while DV_{DD} is below 1.8V. $\overline{RST1}$ can be reprogrammed as a push-pull, active-high, or active-low Status register interrupt output.
10	10	$\overline{RST2}$	Open-Drain Reset Output 2. $\overline{RST2}$ remains low while DV_{DD} is below 2.7V. $\overline{RST2}$ can be reprogrammed as a push-pull, active-high, or active-low Status register interrupt output.
11	11	APIO1	Analog Programmable Input/Output 1
12	12	APIO2	Analog Programmable Input/Output 2
13	13	APIO3	Analog Programmable Input/Output 3
14	14	APIO4	Analog Programmable Input/Output 4
15	15	SNO1	Analog Switch 1 Normally-Open Terminal
16	16	SCM1	Analog Switch 1 Common Terminal
17	17	SNC1	Analog Switch 1 Normally-Closed Terminal
18	18	IN1+	Operational Amplifier 1 Noninverting Input
19	19	IN1-	Operational Amplifier 1 Inverting Input. Also internally connected to ADC mux.
20	20	OUT1	Operational Amplifier 1 Output. Also internally connected to ADC mux.
21	—	N.C.	No Connection. Not internally connected.
22	—	FBB	DACB Force-Sense Feedback Input. Also internally connected to ADC mux.
23	—	OUTB	DACB Force-Sense Output. Also internally connected to ADC mux.
—	21	IN2+	Operational Amplifier 2 Noninverting Input
—	22	IN2-	Operational Amplifier 2 Inverting Input. Also internally connected to ADC mux.
—	23	OUT2	Operational Amplifier 2 Output. Also internally connected to ADC mux.

12-/16-Bit DASs with ADC, DACs, DPIOs, APIOs, Reference, Voltage Monitors, and Temp Sensor

Pin Description (continued)

PIN		NAME	FUNCTION
MAX1329	MAX1330		
24	24	OUTA	DACA Force-Sense Output. Also internally connected to ADC mux.
25	25	FBA	DACA Force-Sense Feedback Input. Also internally connected to ADC mux.
26	26	REFDAC	DAC Internal Reference Buffer Output/DAC External Reference Input. In internal reference mode, REFDAC provides a 1.25V, 2.048V, or 2.5V internal reference buffer output. In external DAC reference buffer mode, disable internal reference buffer. Bypass REFDAC to AGND with a 1 μ F capacitor.
27	27	SNC2	Analog Switch 2 Normally-Closed Terminal
28	28	SCM2	Analog Switch 2 Common Terminal
29	29	SNO2	Analog Switch 2 Normally-Open Terminal
30	30	AIN2	Analog Input 2. Also internally connected to ADC mux.
31	31	AIN1	Analog Input 1. Also internally connected to ADC mux.
32	32	REFADC	ADC Internal Reference Buffer Output/ADC External Reference Input. In internal reference mode, REFADC provides a 1.25V, 2.048V, or 2.5V internal reference buffer output. In external ADC reference buffer mode, disable internal reference buffer. Bypass REFADC to AGND with a 1 μ F capacitor.
33	33	REFADJ	Internal Reference Output/Reference Buffer Amplifiers Input. In internal reference mode, bypass REFADJ to AGND with a 0.01 μ F capacitor. In external reference mode, disable internal reference.
34	34	AGND	Analog Ground
35	35	AVDD	Analog Supply Input. Bypass AVDD to AGND with at least a 0.01 μ F capacitor. With the charge pump enabled, see Table 32 for required capacitor values.
36	36	C1B	Charge-Pump Capacitor Input B. Connect C _{FLY} across C1A and C1B. See Table 32 for required capacitor values.
37	37	C1A	Charge-Pump Capacitor Input A. Connect C _{FLY} across C1A and C1B. See Table 32 for required capacitor values.
38	38	DVDD	Digital Supply Input. Bypass DVDD to DGND with at least a 0.01 μ F capacitor. When using charge pump, see Table 32 for required capacitor values.
39	39	DGND	Digital Ground
40	40	CLKIO	Clock Input/Output. In internal clock mode, enable CLKIO output for external use. In external clock mode, apply a clock signal at CLKIO for the ADC and charge pump.
—	—	EP	Exposed Pad. The exposed pad is located on the package bottom and is internally connected to AGND. Connect EP to the analog ground plane. Do not route any PCB traces under the package.

12-/16-Bit DASs with ADC, DACs, DPIOs, APIOs, Reference, Voltage Monitors, and Temp Sensor

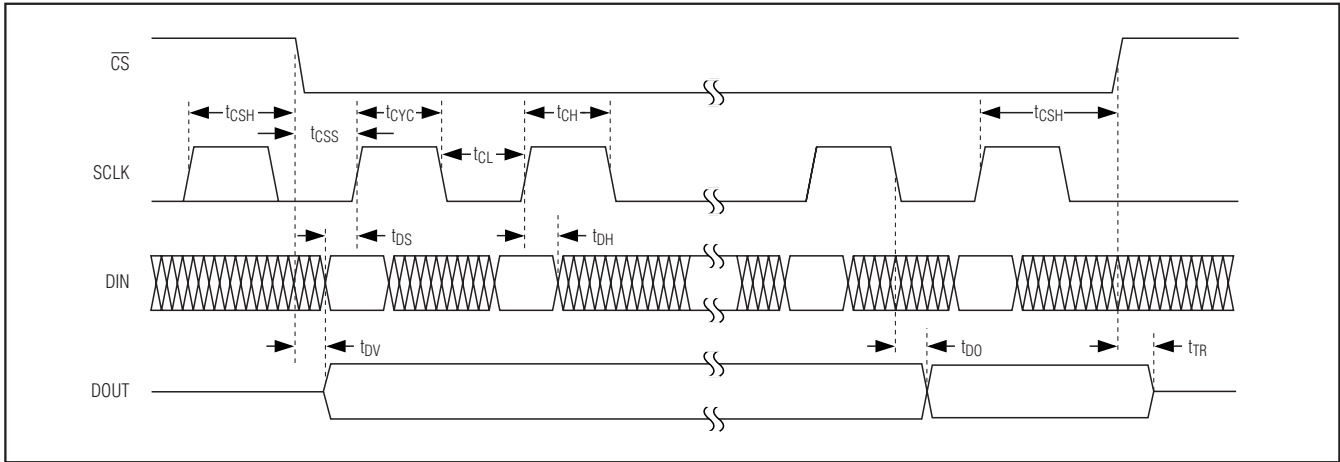

Figure 1. Detailed Serial-Interface Timing Diagram

Detailed Description

The MAX1329/MAX1330 smart DASs are based on a 312ksps, 12-bit SAR ADC with a 1ksps, 16-bit DSP mode. The ADC includes a differential multiplexer, a programmable gain amplifier (PGA) with gains of 1, 2, 4, and 8, a 20-bit accumulator, internal dither, a 16-word FIFO, and an alarm register. The MAX1329/MAX1330 operate with a digital supply down to 1.8V and feature an internal charge pump to boost the supply voltage for the analog circuitry that requires 2.7V to 5.5V.

The MAX1329/MAX1330 include an internal reference with programmable buffer for the ADC, two analog external inputs as well as inputs from other internal circuitry, an internal/external temperature sensor, internal oscillator, dual single-pole, double-throw (SPDT) switches, four digital programmable I/Os, four analog programmable I/Os, and dual programmable voltage monitors.

The MAX1329 features dual 12-bit force-sense DACs with programmable reference buffer and one operational amplifier. The MAX1330 includes one 12-bit force-sense DAC with programmable reference buffer and dual op amps. DACA can be sequenced with a 16-word FIFO. The DAC buffers and op amps have internal analog switches between the output and the inverting input.

Power-On Reset

After a power-on reset, the DV_{DD} voltage supervisor is enabled with thresholds at 1.8V and 2.7V. All digital and analog programmable I/Os (DPIOs and APIOs) are configured as inputs with pullups enabled. The internal oscillator is enabled and is output at CLKIO once the 1.8V reset trip threshold has been exceeded and the subsequent timeout period has expired. See the

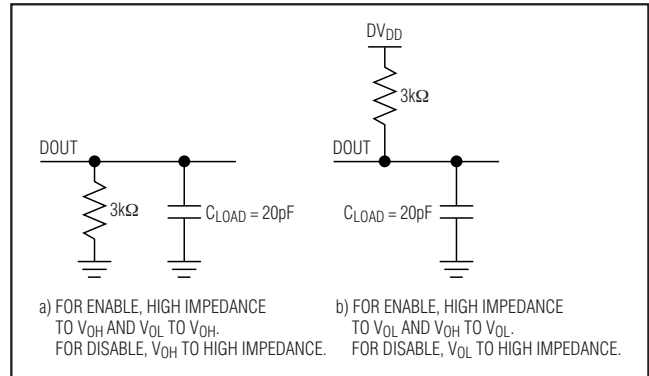

Figure 2. DOUT Enable and Disable Time Load Circuits

Register Bit Descriptions section for the default values after a power-on reset.

Power-On Setup

After applying power to AV_{DD}:

- 1) Write to the Reset register. This initializes the temperature sensor and voltage reference trim logic.
- 2) Within 3ms following the reset, configure the charge pump as desired by writing to the CP/VM Control register. The details of programming the charge pump are described in the Charge Pump section.

Charge Pump

Power AV_{DD} and DV_{DD} by any one of the following ways: drive AV_{DD} and DV_{DD} with a single external power supply, drive AV_{DD} and DV_{DD} with separate external power supplies, or drive DV_{DD} with an external supply and enable the internal charge pump to generate AV_{DD} or short DV_{DD} to AV_{DD} internally.

12-/16-Bit DASs with ADC, DACs, DPIOs, APIOs, Reference, Voltage Monitors, and Temp Sensor

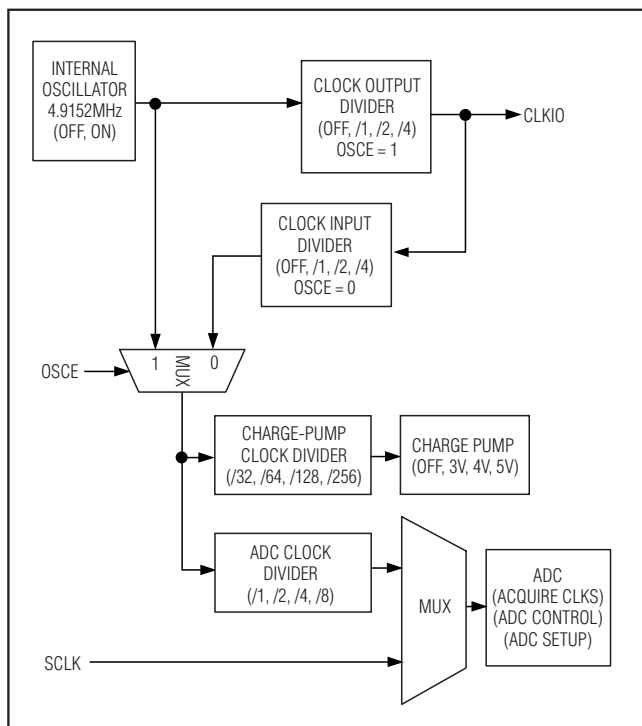

Figure 3. Clock-Divider Block Diagram

Upon a power-on reset, the charge pump is disabled. Enable the charge pump through the CP/VM Control register. When the charge pump is in its off state, AVDD is isolated from DVDD unless the bypass switch is enabled. To bypass the charge pump and directly connect DVDD to AVDD, enable (close) the bypass switch through the CP/VM Control register (see Tables 21 and 22). During the on mode, the charge pump boosts DVDD and regulates the voltage to generate the selected output voltage at AVDD. The charge-pump output voltage selections are 3.0V, 4.0V, or 5.0V.

The charge-pump clock and ADC clock are synchronized from the same master clock. The charge pump uses a pulse-width-modulation (PWM) scheme to regulate the output voltage. The charge pump supports a maximum load of 25mA of current to an external device including what is required for internal circuitry.

Power Modes

Three power modes are available for the MAX1329/MAX1330: shutdown, sleep, and normal operation. In shutdown mode, all functional blocks are powered down except the serial interface, data registers, and wake-up circuitry (if enabled). Sleep mode is identical to shutdown mode except the DVDD voltage monitors (if enabled) remain active. Global sleep or shutdown mode is initiated through a

DPIO configured as $\overline{\text{SLP}}$ or $\overline{\text{SHDN}}$ inputs. In normal mode, each analog and digital block can be powered up or shut down individually through its respective control register.

Voltage Supervisors

The MAX1329/MAX1330 provide two programmable voltage supervisors, one for DVDD and one for AVDD. The DVDD voltage supervisor has two thresholds (set to 1.8V and 2.7V by default) that are both enabled after a power-on reset. On initial power-up, $\overline{\text{RST1}}$ is assigned the 1.8V monitor output and $\overline{\text{RST2}}$ is assigned the 2.7V monitor output, both for DVDD. If DVDD falls below the 1.8V or 2.7V threshold, the VM1A bit or VM1B bit, respectively, in the Status register is set. The VM1A and VM1B status bits can also be mapped to the interrupt generator. The default states of $\overline{\text{RST1}}$ and $\overline{\text{RST2}}$ are open-drain outputs but can be programmed as push-pull Status register interrupts through the CP/VM Control register.

The AVDD voltage supervisor provides three programmable thresholds. If AVDD falls below the programmed threshold, the VM2 bit is set in the Status register. The VM2 status bit can also be mapped to the interrupt generator.

Interrupt Generator

The interrupt generator accepts inputs from other internal circuits to provide an interrupt to an external microcontroller (μC). The sources for generating an interrupt are programmable through the serial interface. Possible sources include a rising or falling edge on the digital and analog programmable inputs, ADC alarms, an ADC conversion complete, an ADC FIFO full, an ADC accumulator full, and the voltage-supervisor outputs. The interrupt causes $\overline{\text{RST1}}$ and/or $\overline{\text{RST2}}$ to assert when configured as an interrupt output. The interrupt remains asserted until the Status register is read. See the CP/VM Control register for programming the $\overline{\text{RST1}}$ and $\overline{\text{RST2}}$ outputs as interrupts and the Interrupt Mask register for programming the interrupt sources.

Internal Oscillator and Programmable Clock Dividers

The MAX1329/MAX1330 feature an internal oscillator, which operates at a fixed frequency of 3.6864MHz. When enabled, the internal oscillator provides the master clock source for the ADC and charge pump. To allow external devices to use the internally generated clock, configure CLKIO as an output through the Clock Control register. The CLKIO output frequency is configurable for 0.9216MHz, 1.8432MHz, and 3.6864MHz. When the internal oscillator is enabled, and regardless of the CLKIO output frequency, the ADC and charge-pump clock dividers always receive a 3.6864MHz clock signal (see Figure 3). After a power-on reset, CLKIO defaults to an output with the divider set to 2 (resulting in 1.8432MHz).

12-/16-Bit DASs with ADC, DACs, DPIOs, APIOs, Reference, Voltage Monitors, and Temp Sensor

For external clock mode, disable the internal oscillator, which then configures CLKIO as an input. Apply an external clock at CLKIO with a frequency up to 20MHz. The input clock divider can be set to 1, 2, or 4. The output of the CLKIO input divider goes to the input of charge pump and ADC clock dividers.

Note: When using the internally generated clock, entering shutdown or sleep mode causes CLKIO to become an input. To prevent crowbar current, connect a 500k Ω resistor from CLKIO to DGND.

Digital and Analog Programmable I/Os

The MAX1329/MAX1330 provide four digital programmable I/Os (DPIO1–DPIO4) and four analog programmable I/Os (APIO1–APIO4). The DPIOs and APIOs can be configured as logic inputs or outputs through the DPIO and APIO Control registers. The DPIOs are powered by DV_{DD}. Likewise, the APIOs are powered by AV_{DD}. When configured as inputs, internal pullups can be enabled through the DPIO and APIO Setup registers.

Digital Programmable I/O

DPIO1–DPIO4 are powered by DV_{DD} and are programmable as the following:

- General-purpose input
- Wake-up input (internal oscillator enable)
- Power-down mode (sleep or shutdown) control input
- DAC loading or sequencing input
- ADC acquisition and conversion control input
- DAC, op amp, and SPDT switch control input
- ADC data-ready output
- General-purpose output

Analog Programmable I/O

APIO1–APIO4 are powered by AV_{DD} and are programmable as the following:

- General-purpose input
- Wake-up input (internal oscillator enable)
- General-purpose output
- Digital input/output for signals to be level-shifted from/to the SPI interface

Temperature Sensor

An internal temperature sensor measures the device temperature of the MAX1329/MAX1330. The ADC converts the analog measurement from the internal temperature sensor to a digital output (see Table 1). The temperature measurement resolution is +0.125 $^{\circ}$ C for each LSB and the measured temperature can be calculated using the following equation:

$$T = \text{ADC output data}/8^{\circ}\text{C}$$

Table 1. Temperature vs. ADC Output

TEMPERATURE ($^{\circ}$ C)	ADC OUTPUT DATA	
	TWO'S COMPLEMENT	HEX
+85.000	0010 1010 1000	2A8
+70.000	0010 0011 0000	230
+25.000	0000 1100 1000	0C8
+0.250	0000 0000 0010	002
+0.125	0000 0000 0001	001
0	0000 0000 0000	000
-0.125	1111 1111 1111	FFF
-0.250	1111 1111 1110	FFE
-25.000	1111 0011 1000	F38
-40.000	1110 1100 0000	EC0

where ADC output data is the decimal value of the two's complement result.

The MAX1329/MAX1330 support external single-ended and differential temperature measurements using a diode connected transistor between AIN1 and AGND, AIN2 and AGND, or AIN1 and AIN2. Select the appropriate channel for conversion through the ADC Setup register.

Voltage References

The internal unbuffered 2.5V reference is externally accessible at REFADJ. Separate ADC and DAC reference buffers are programmable to output 1.25V, 2.048V, or 2.5V REFADC and REFDAC. The reference and buffers can be individually controlled through the ADC Control and DAC Control registers. Power down the internal reference to apply an external reference at REFADJ as an input to the ADC and DAC reference buffers. Power down the reference buffers to apply external references directly at REFADC and REFDAC.

Note: All temperature sensor measurements use the voltage at REFADJ as a reference and require a 2.5V reference for accurate results.

Operational Amplifiers

The MAX1329 includes one uncommitted operational amplifier. The MAX1330 includes two op amps. These op amps feature rail-to-rail inputs and outputs, with a bandwidth of 1MHz. The op amps are powered down through the DAC Control register. An internal analog switch shorts the negative input to the output when enabled through the Switch Control register or a DPIO configured as a switch control input. When powered down, the outputs of the op amps go high impedance.

12-/16-Bit DASs with ADC, DACs, DPIOs, APIOs, Reference, Voltage Monitors, and Temp Sensor

Single-Pole/Double-Throw (SPDT) Switches

The MAX1329/MAX1330 provide two uncommitted SPDT switches that can also be configured as a double-pole/single-throw (DPST) switch (see Tables 28 and 29). Each switch has a typical on-resistance of 115Ω at $V_{DD} = 3V$. The switch is controlled through the Switch Control register or a DPIO configured to control the switches.

Analog-to-Digital Converter (ADC)

The MAX1329/MAX1330 include a 12-bit SAR ADC with a programmable-gain amplifier (PGA), input multiplexer, and digital post-processing. The analog input signal feeds into the differential input multiplexer and then into the PGA with gain settings of 1, 2, 4, or 8. The temperature sensor and supply voltage measurements bypass the PGA. Both unipolar and bipolar transfer functions are selectable.

The ADC done status bit (ADD in the Status register) can be programmed to provide an interrupt. Any of the DPIOs can be configured as a CONVST input to directly control the acquisition time and synchronize the conversions. A 16-word FIFO stores the ADC results until the 12-bit data is read by the external μC .

Analog Inputs

The MAX1329/MAX1330 provide two external analog inputs: AIN1 and AIN2. The inputs are rail-to-rail and can be used differentially or single-ended to ground. The analog inputs can also be used for remote temperature sensing with external diodes.

AIN1 and AIN2 feed directly into a differential multiplexer. This 16-channel multiplexer is segmented into an upper and a lower multiplexer (see Tables 7 and 8 for configuration).

ADC FIFO Register

The ADC writes its results in the ADC FIFO, which stores up to sixteen 16-bit words. Each 16-bit word in the FIFO includes a 4-bit FIFO address and the 12-bit data result from the ADC. The ADC FIFO includes four pointers: depth, interrupt, write, and read configured by writing to the ADC FIFO register (see Figure 4).

A depth pointer sets the working depth of the FIFO such that locations beyond the depth pointer are inaccessible for writing or reading. The interrupt pointer sets the location that causes an interrupt every time data has been written to that location. Set the interrupt pointer to the same or lower location than the depth pointer. The interrupt pointer is set equal to the depth pointer if written with a value greater than the depth pointer. A write to the ADC FIFO register causes the write and read pointers to reset to location 0. Setting the depth pointer to location 0 disables the FIFO.

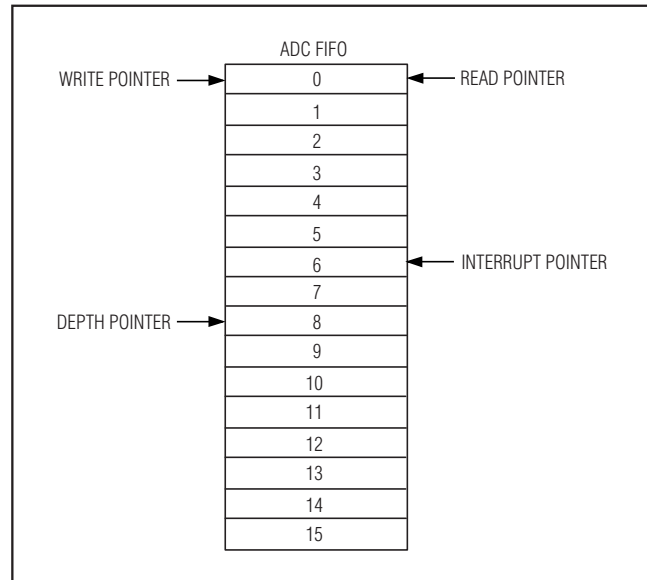

Figure 4. ADC FIFO

Every time a conversion completes, the data is written to the present location of the write pointer, which then increments by 1. The write pointer continues to increment until the depth pointer location has been written. The write pointer then moves to location 0 and continues to increment but must remain behind the read pointer. Once the last valid FIFO location has been written, no further ADC results are written to the FIFO until the next FIFO location is cleared by a read.

When the ADC FIFO is enabled, the read pointer points to location 0. When a read occurs, the pointer then increments by 1 only if 15 of the 16 bits are clocked out successfully. Reading the FIFO is done in 16-bit words consecutively as long as a serial clock is present. The read pointer must stay one location behind the write pointer. When the write pointer is one location ahead of the read pointer and the read continues, it clocks out the current read location over and over again until the write pointer increments.

The FIFO can be accessed simultaneously by the serial interface to read a result and by the ADC to write a result, but the read and write pointers are never at the same address.

ADC Accumulator, Decimation, and Dither Mode

The accumulator is used for oversampling. In this mode, up to 256 samples are accumulated in the ADC Accumulator register. This is a 24-bit read register with 1 bit for dither enable, 3 bits for the accumulator count, and 20 bits for the accumulated ADC conversions. The

12-/16-Bit DASs with ADC, DACs, DPIOs, APIOs, Reference, Voltage Monitors, and Temp Sensor

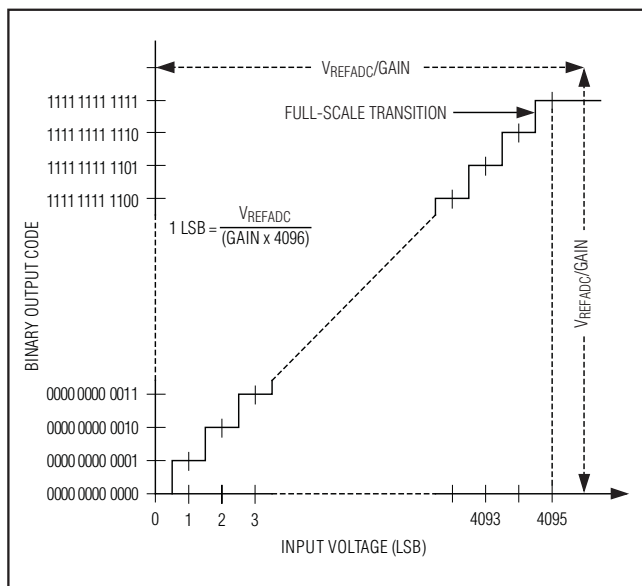

Figure 5. Unipolar Transfer Function

accumulator is functional for the normal, fast power-down, and burst modes, but cannot be used for temperature-sensor conversions.

The 20-bit binary accumulator provides up to 256 times oversampling and binary digital filtering. The digital filter has a sinc response and the notch locations are determined by the sampling rate and the oversampling ratio (see the *Applying a Digital Filter to ADC Data Using the 20-Bit Accumulator* section). There is a digital-signal-processing mode where dither is added to the oversampling to extend the resolution from 12 to 16 bits. In this mode, a sample rate of 1220sps can be maintained. The oversampling rate (OSR) required to achieve an increase in resolution is $OSR = 2^{2N}$, where N is the additional bits of resolution. See the *ADC Accumulator Register* section.

ADC Alarm Mode

The ADC Greater-Than (GT) and Less-Than (LT) Alarm registers can be used to generate an interrupt once the ADC result exceeds the alarm register value. The alarm registers also control the number of alarm trips required and whether or not they need to be consecutive to generate an interrupt. The GT and LT alarms are programmed through the ADC GT and LT Alarm registers. The alarms are functional for the normal, fast power-down, and burst modes.

ADC Transfer Functions

Figures 5 and 6 provide the ADC transfer functions for unipolar and bipolar mode. The digital output code

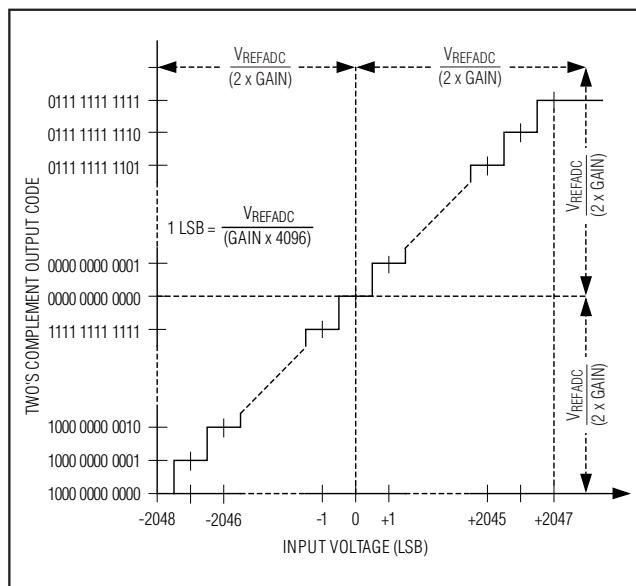

Figure 6. Bipolar Transfer Function

format is binary for unipolar mode and two's complement for bipolar mode. Calculate 1 LSB using the following equation:

$$1 \text{ LSB} = V_{REFADC} / (\text{gain} \times 4096)$$

for both unipolar and bipolar modes,

where V_{REFADC} is the reference voltage at REFADC and gain is the PGA gain. In unipolar mode, the output code ranges from 0 to 4095 for inputs from zero to full-scale. In bipolar mode, the output code ranges from -2048 to +2047 for inputs from negative full-scale to positive full-scale.

Digital-to-Analog Converter (DAC)

The MAX1329 includes two 12-bit DACs (DACA and DACB) and the MAX1330 includes one 12-bit DAC (DACA). The DACs feature force-sense outputs and DACA includes a 16-word FIFO. Each DAC is double-buffered with an input and output register (see Figure 7). The DACA(B)PD<1:0> bits in the DAC Control register control the power and write modes for DACA and DACB.

With the DAC(s) powered-up, the three possible commands are a write to both the input and output registers, a write to the input register only, or a shift of data from the input register to the output register. With the DAC(s) powered-down, only a simultaneous write to both input and output registers is possible. DPIO_ can be programmed to shift the input register data to the output register for each DAC individually or simultaneously (MAX1329 only). The value in the output register

12-/16-Bit DASs with ADC, DACs, DPIOs, APIOs, Reference, Voltage Monitors, and Temp Sensor

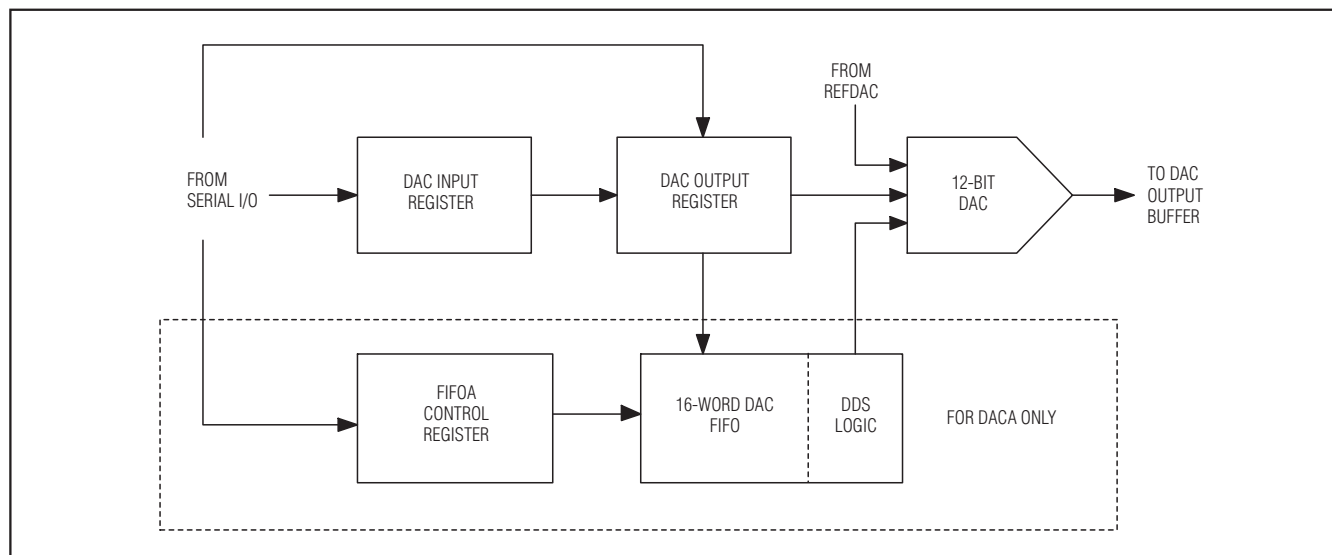

Figure 7. Detailed DAC and FIFO Block Diagram

determines the analog output voltage. An internal switch configures the force-sense output for unity gain configuration when it is closed.

In power-down mode, the DAC outputs and feedback inputs are high impedance.

DACA FIFO and Direct Digital Synthesis (DDS) Logic

The DACA FIFO and DDS logic can be used for waveform synthesis by loading the FIFO and configuring the DDS mode through the FIFOA Control register. The FIFO is sequenced by writing to the FIFO Sequence register address or by toggling a DPIO configured for this function.

The input register value, in conjunction with the FIFOA Data register values, can be used to create waveforms. The FIFOA Data register values are added to or subtracted from the Input register value before shifting to the output register. The FIFO data is straight binary (0 to +4095) when the bipolar bit (BIPA) is not asserted and as sign magnitude (-2047 to +2047) when BIPA is asserted. In sign magnitude mode, the MSB represents the sign bit, where 0 indicates a positive number and 1 indicates a negative number. The 11 LSBs provide the magnitude in sign magnitude.

The type of waveform generated is determined by the asymmetric/symmetric mode bit (SYMA), unipolar/bipolar mode bit (BIPA), and the single/continuous mode bit (CONA). All waveforms are generated in phases (see Figure 8). For all bit combinations, phase 1 is created by first shifting the input register value to the output reg-

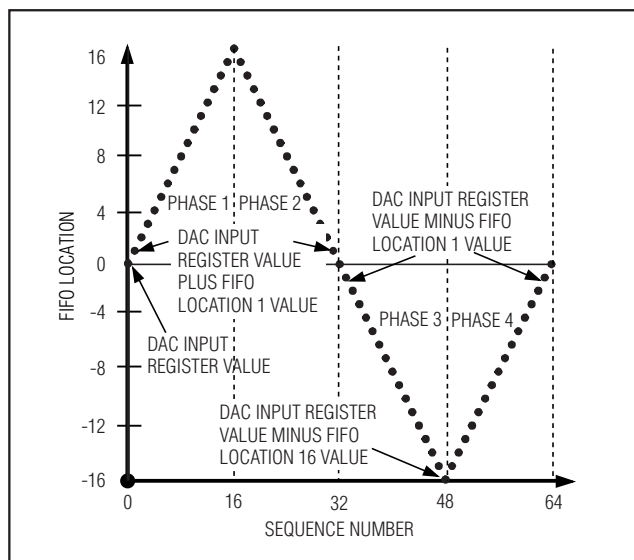
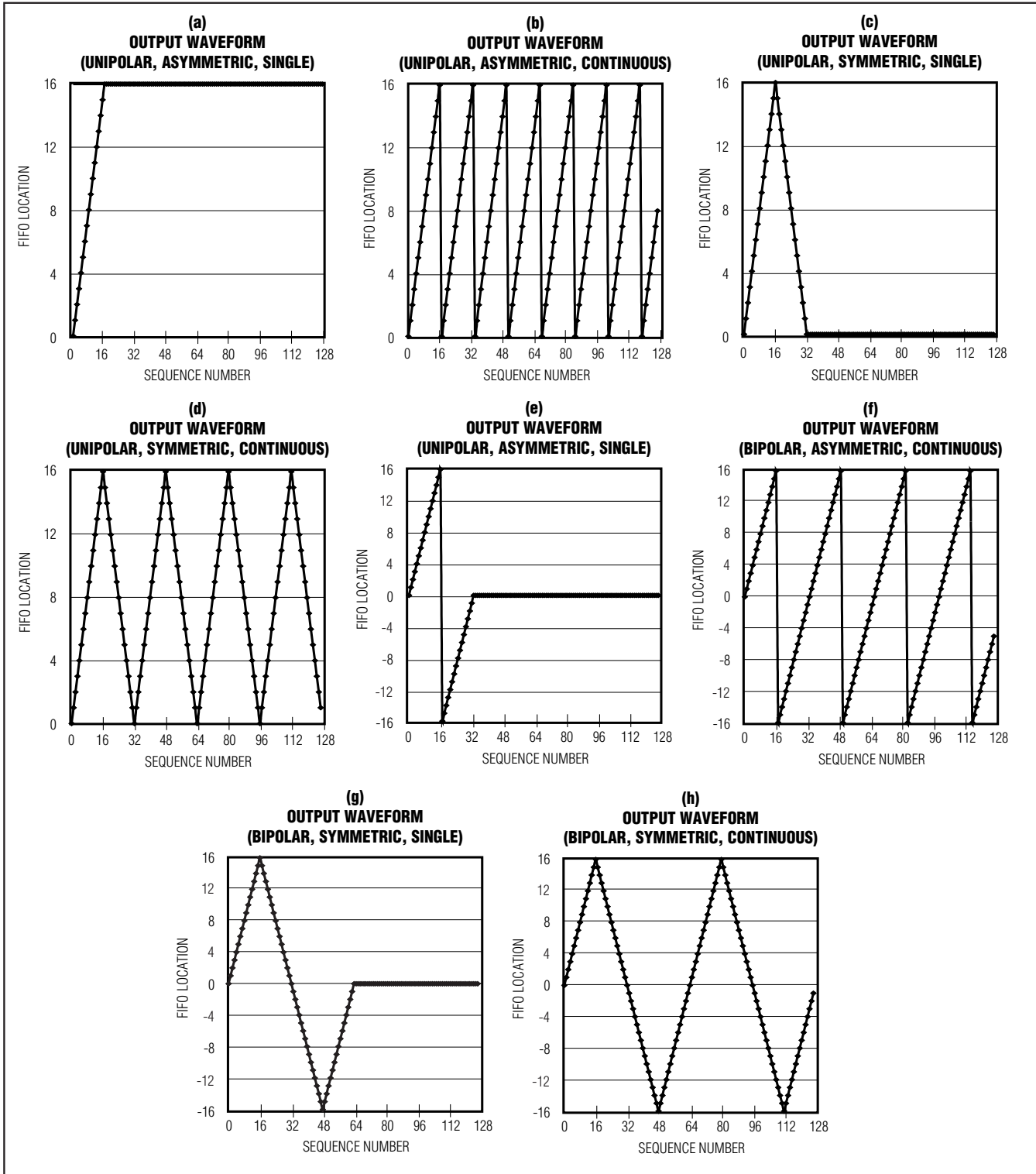

Figure 8. DAC FIFO Waveform Phases

ister. For each subsequent sequence, the FIFOA Data register value is added to the input register before shifting to the output register until the programmed FIFO depth has been reached (see Figure 9a). The FIFO depth ($DPTA<3:0>$) can be set to any integer value from 1 to 16 and the FIFO always starts at location 1.

Asserting the SYMA bit creates phase two by causing the FIFO to reverse direction at the end of phase 1 without repeating the final value before sequencing back to the beginning (see Figure 9c).

12-/16-Bit DASs with ADC, DACs, DPIOs, APIOs, Reference, Voltage Monitors, and Temp Sensor



Figures 9a–9h. Waveform Examples Using the DAC FIFO

12-/16-Bit DASs with ADC, DACs, DPIOs, APIOs, Reference, Voltage Monitors, and Temp Sensor

Table 2. Direct-Mode Definitions

COMMAND NAME	START	CONTROL			
		MUX<3:0>	GAIN<1:0>	BIP	
ADC Convert	1	MUX<3:0>		GAIN<1:0>	BIP
DACA Write	0	1	R/W	0	DACA<11:0>
DACB Write	0	1	R/W	1	DACB<11:0>
Register Mode*	0	0	R/W	ADDRESS (ADR<4:0>)	DATA (D<255:0>, D<23:0>, D<15:0>, or D<7:0>)

*See Table 3.

Asserting the BIPA bit with SYMA = 1 creates phases three and four (see Figure 9g). Phases three and four repeat the same sequence as in phases one and two, respectively, but the FIFO data is subtracted from the input register data this time through. The final value in phase two is not repeated before proceeding with phase three. The resulting waveform is composed of all four phases.

Asserting the BIPA bit with SYMA = 0 creates phase four (see Figure 9e). Phase four repeats the same sequence as in phase one in reverse order, but the FIFO data is subtracted from the input register data. In this case, the last location in the FIFO is repeated before sequencing back to the beginning.

When the CONA bit is not asserted, the output is static once the end of the programmed pattern has been reached. Asserting the CONA bit causes the patterns described above to repeat without repeating the final value (see Figures 9b, 9d, 9f, and 9h).

The FIFO Enable bit (FFEA) enables the ability to create waveforms. The FFEA must be disabled to write to the FIFOA Data register. Any change in the FIFOA Control register reinitializes the FIFO sequencing logic and the next sequence loads the input register value. The DACA Input and/or Output registers can be written directly and not affect the sequencing logic. Writing to the DACA input register effectively moves the DC offset of the waveform on the next sequence and writing to the DACA output register immediately changes the output level independent of the FIFO.

Serial Interface

The MAX1329/MAX1330 feature a 4-wire serial interface consisting of a chip select (\overline{CS}), serial clock (SCLK), data in (DIN), and data out (DOUT). \overline{CS} must be low to allow data to be clocked into or out of the shift register. DOUT is high-impedance while \overline{CS} is high, unless APIO1 is programmed for SPI mode. The data is clocked in at DIN into the shift register on the rising edge of SCLK. Data is clocked out at DOUT on the

falling edge of SCLK. The serial interface is compatible with SPI modes CPOL = 0, CPHA = 0 and CPOL = 1, CPHA = 1. A write operation takes effect on the rising edge of SCLK used to shift in the LSB (or last bit of the data word being written). If \overline{CS} goes high before the complete transfer, the write is ignored. \overline{CS} must be forced high between commands.

Direct-Mode Commands

The direct-mode commands include the ADC Convert command and DACA and DACB Read and Write commands. The ADC Convert command is an 8-bit command that initiates an ADC conversion, selects the conversion channel through the multiplexer, sets the PGA gain, and selects bipolar or unipolar mode. If an ADC Convert command is issued during a conversion in progress, the current conversion aborts and a new one begins. The MUX<3:0>, GAIN<1:0>, and BIP bits settings in the ADC Setup register are overwritten by the values in the ADC Convert command.

The DACA and DACB Data Write commands set the DACA and DACB input and/or output register values, respectively. The DACA and DACB data write modes are determined by the DAC Control register. The DACA and DACB data read commands read the DACA and DACB input register data, respectively.

In register mode, an address byte identifies each register. The data registers are 8, 16, or 24 bits wide. The ADC and DACA FIFO Data registers are variable length up to 256 bits wide. Figures 10–17 provide example timing diagrams for various commands.

ADC Conversion Timing

Configure the ADC Control and Setup registers before attempting any conversions. Initiate an ADC conversion with the 8-bit ADC Convert command (see Table 2) or by toggling a DPIO input configured for an ADC conversion-start function. When a conversion completes, the result is ready to be read in the data register. In burst mode, the ADC data is delivered real time on DOUT.

12-/16-Bit DASs with ADC, DACs, DPIOs, APIOs, Reference, Voltage Monitors, and Temp Sensor

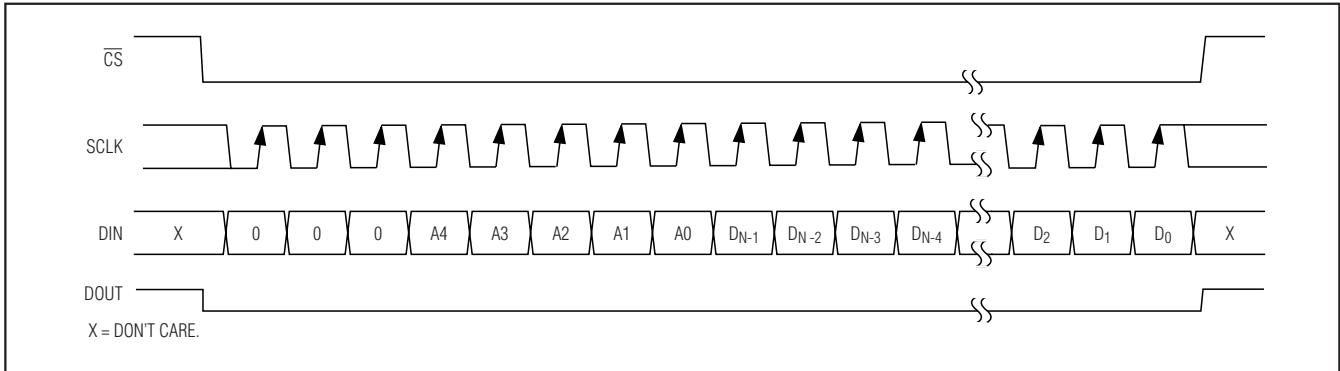

Figure 10. Variable Length Register-Mode Data-Write Operation

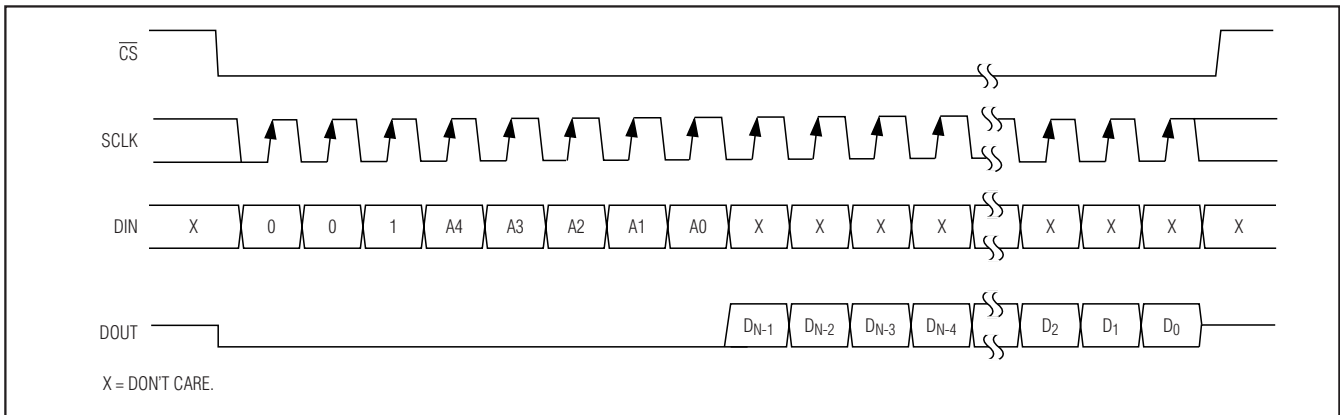

Figure 11. Variable Length Register-Mode Data-Read Operation

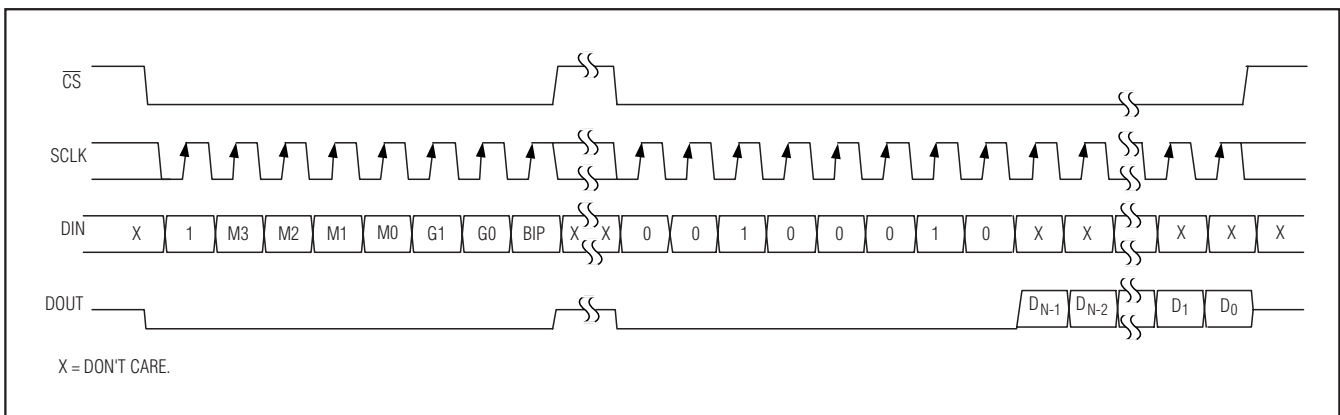

Figure 12. Write Command to Start a Normal or Fast Power-Down ADC Conversion Followed by ADC Data Register Read

12-/16-Bit DASs with ADC, DACs, DPIOs, APIOs, Reference, Voltage Monitors, and Temp Sensor

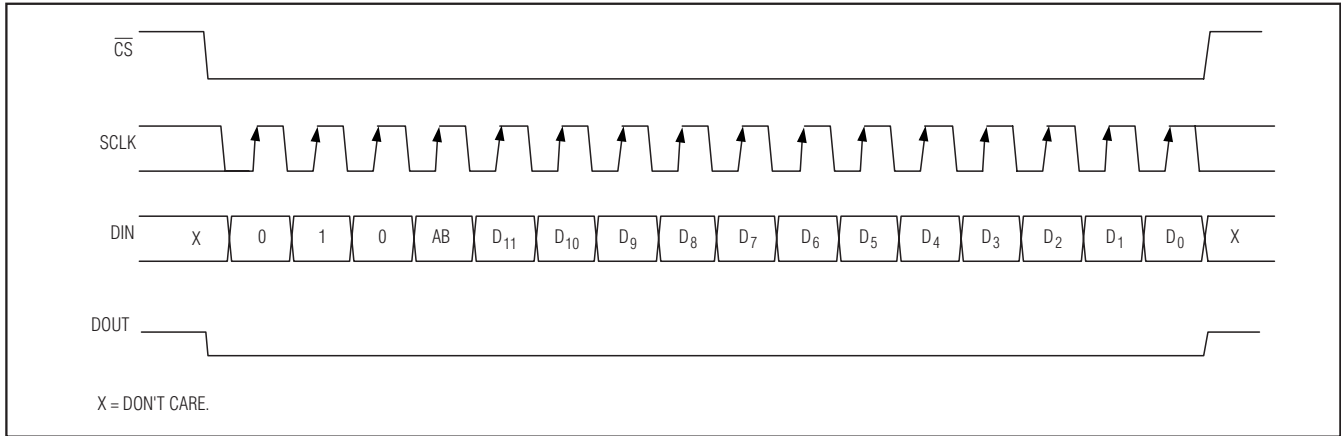

Figure 13. Write to DACA (AB = 0) or DACB (AB = 1). The DAC Control register programs the write mode.

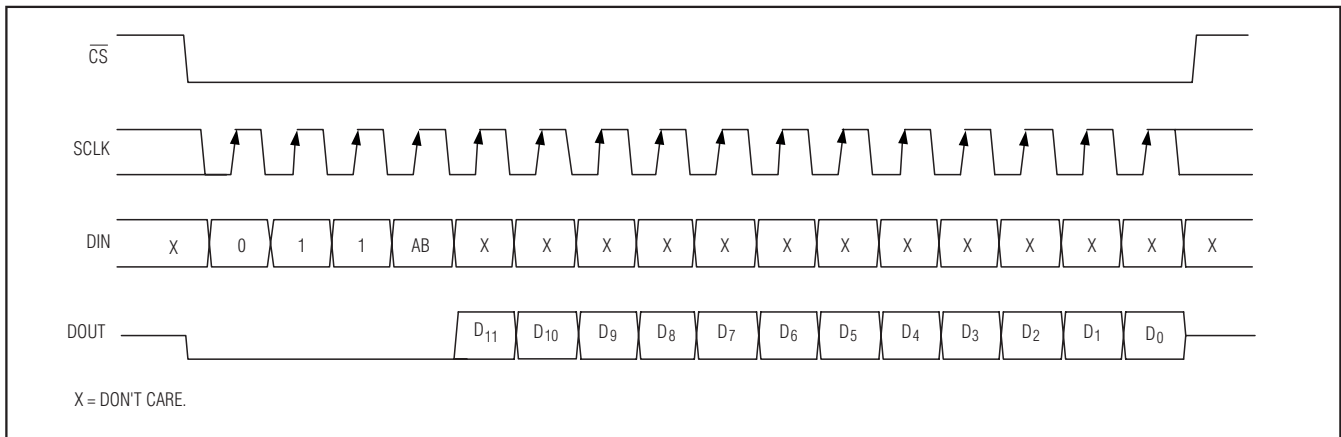

Figure 14. Read of DACA (AB = 0) or DACB (AB = 1) Input Register

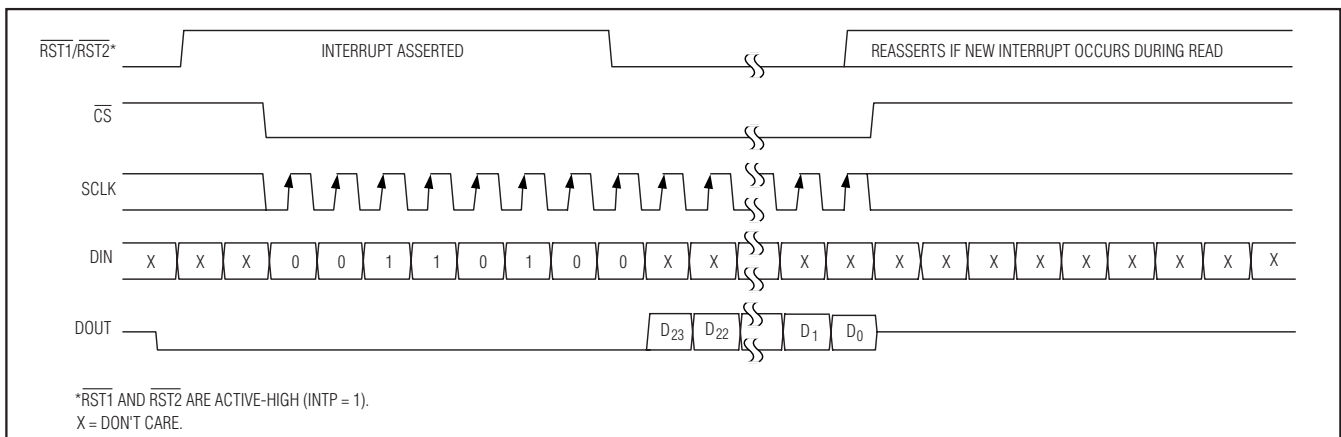

Figure 15. Read of Status Register to Clear Asserted Interrupt ($\overline{RST1}/\overline{RST2}$)

12-/16-Bit DASs with ADC, DACs, DPIOs, APIOs, Reference, Voltage Monitors, and Temp Sensor

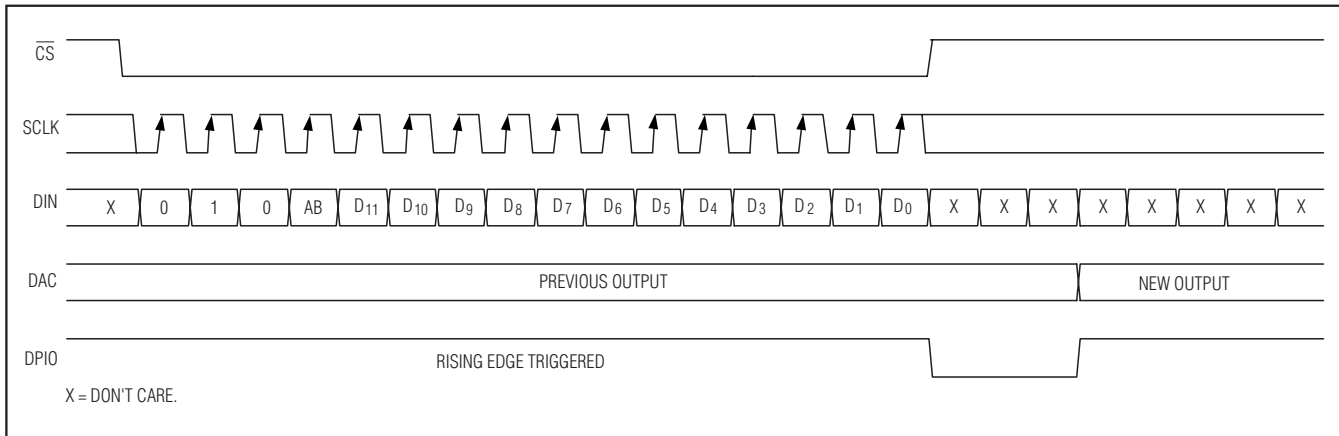

Figure 16. Write to DACA (AB = 0) or DACB (AB = 1) Input Register Followed by a DPIO DACA or DACB Load

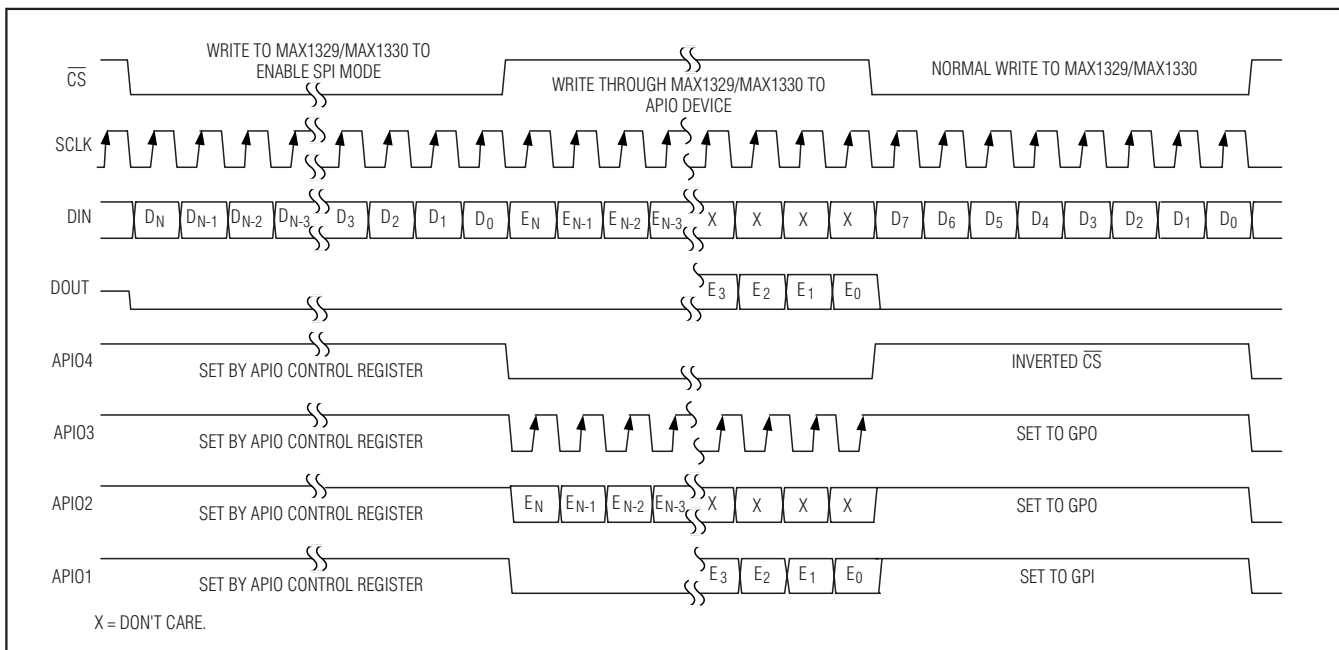

Figure 17. Write to Program and Use APIO SPI Mode

The four conversion modes programmed by the APD<1:0> and AUTO<2:0> bits in the ADC Control register are: autoconvert, fast power-down, normal, and burst modes. In normal and fast power-down modes, single conversions are initiated with the ADC convert command or by toggling a configured DPIO. In fast power-down mode, the PGA and ADC power down between conversions to reduce power. A minimum of 16 clock cycles is required to complete a conversion in normal or fast power-down mode.

Burst mode is initiated with one ADC convert command and continuously converts on the same channel sending the data directly to DOUT as long as there is activity on SCLK and CS is low. Burst mode aborts when CS goes high. In burst mode, SCLK directly clocks the ADC. For best performance, synchronize SCLK with the CLKIO clock (see Figure 18). A minimum of 14 clock cycles is required to complete a conversion in burst mode.

12-/16-Bit DASs with ADC, DACs, DPIOs, APIOs, Reference, Voltage Monitors, and Temp Sensor

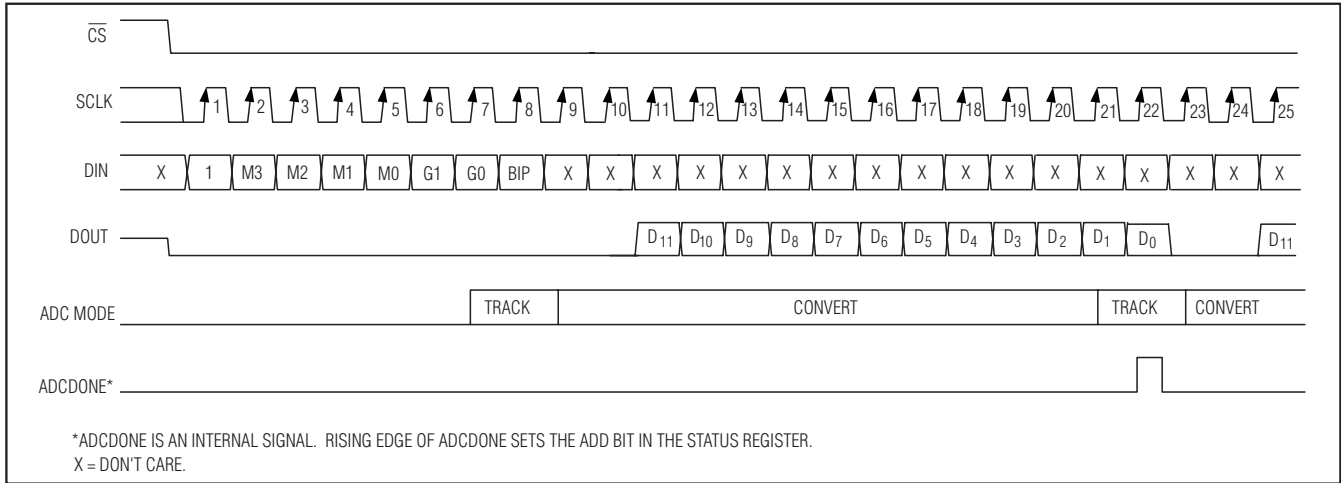

Figure 18. Write Command to Start ADC Burst Conversions Clocked by SCLK with Real-Time Data Read (ACQCK<1:0> = 00, GAIN<1:0> = 00)

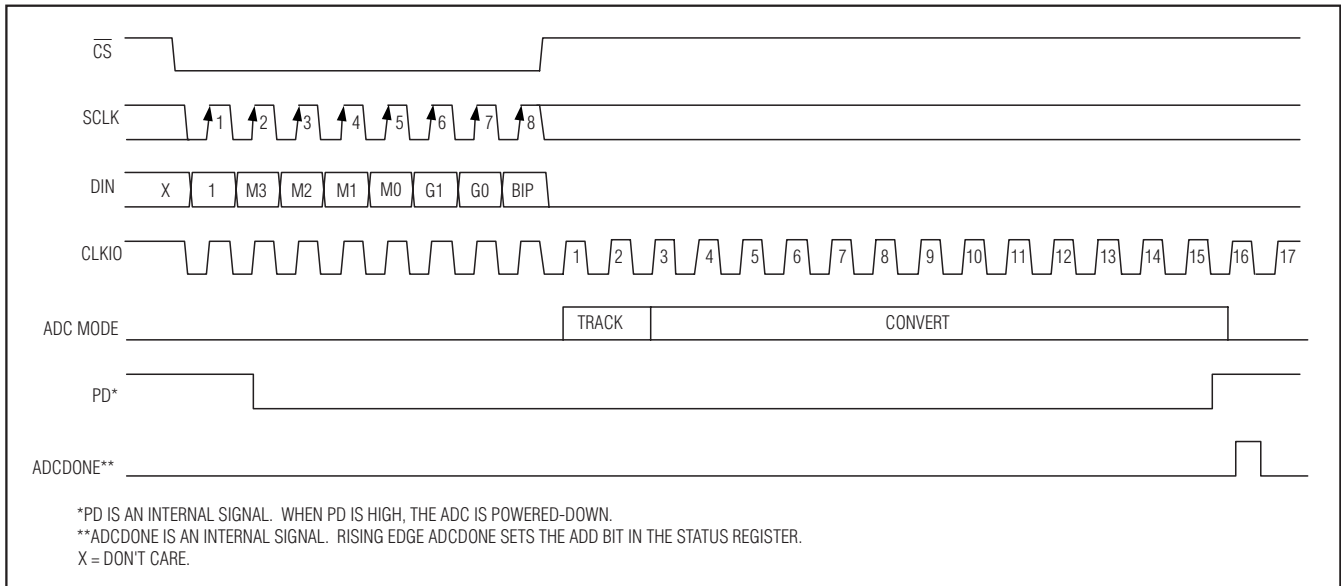

Figure 19. Write Command to Start ADC Normal or Fast Power-Down, with Autoconvert Disabled (AUTO<2:0> = 000) and Conversions Clocked by CLKIO (OSCE = 0, ADDIV<1:0> = 00, CLKIO<1:0> = 11)

12-/16-Bit DASs with ADC, DACs, DPIOs, APIOs, Reference, Voltage Monitors, and Temp Sensor

Once configured, autoconvert mode initiates with one ADC Convert command. Conversions continue at the rate selected by the ADC Autoconvert bits (see Table 4) until disabled by writing to the ADC Control register. The Autoconvert mode can run only in the normal or fast power-down modes. The autoconvert function must be disabled to use burst mode or DPIO CONVST mode.

When writing to the ADC Control register in fast power-down mode with autoconvert disabled, acquisition begins on the 1st rising ADC clock edge after \overline{CS} transitions high, and ends after the programmed number of clock cycles. The conversion completes a minimum 14 clock cycles after acquisition ends. When autoconvert is enabled, an additional three ADC clock cycles are added prior to acquisition to allow the ADC to wake up. See Figures 19 and 20 for timing diagrams.

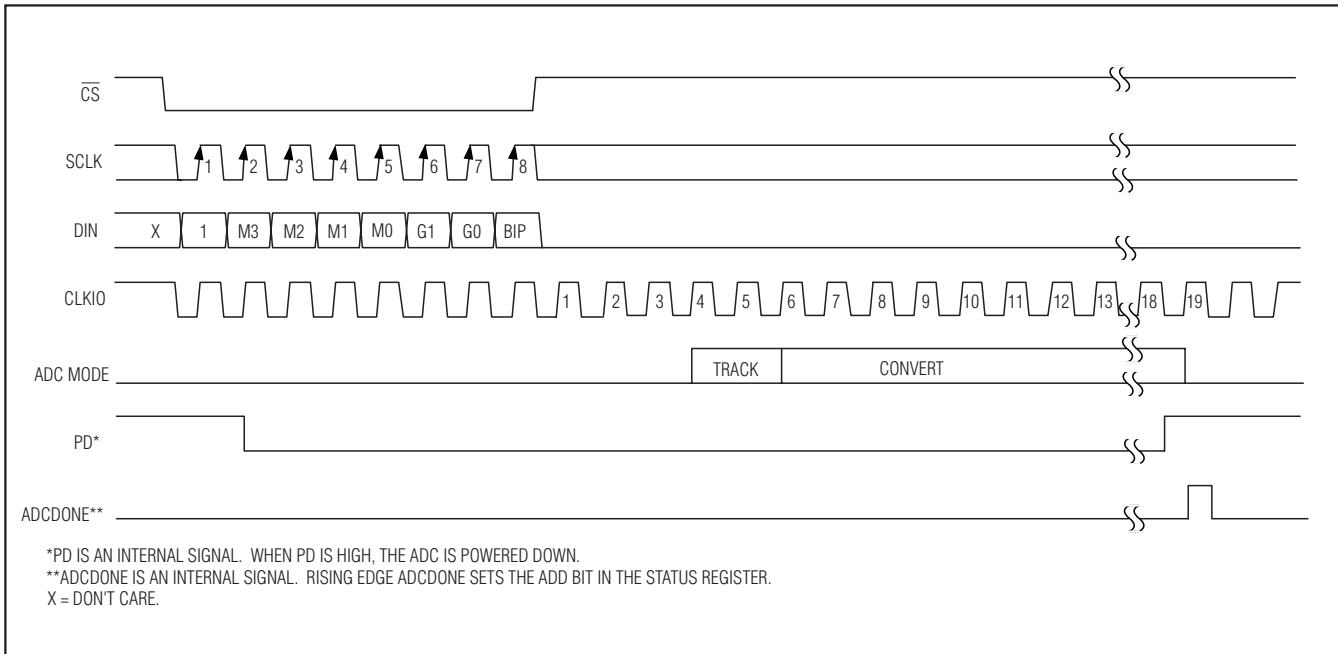

Figure 20. Write Command to Start ADC Normal or Fast Power-Down, with Autoconvert Enabled and Conversions Clocked by CLKIO (OSCE = 0, ADDIV<1:0> = 00, CLKIO<1:0> = 11)

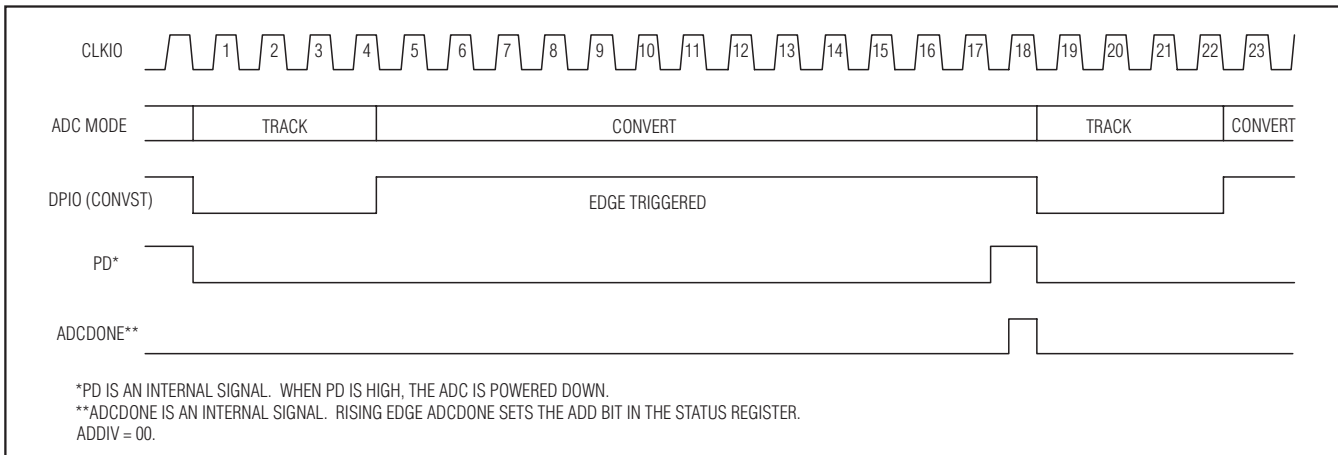

Figure 21. DPIO-Controlled ADC Conversion Start

12-/16-Bit DASs with ADC, DACs, DPIOs, APIOs, Reference, Voltage Monitors, and Temp Sensor

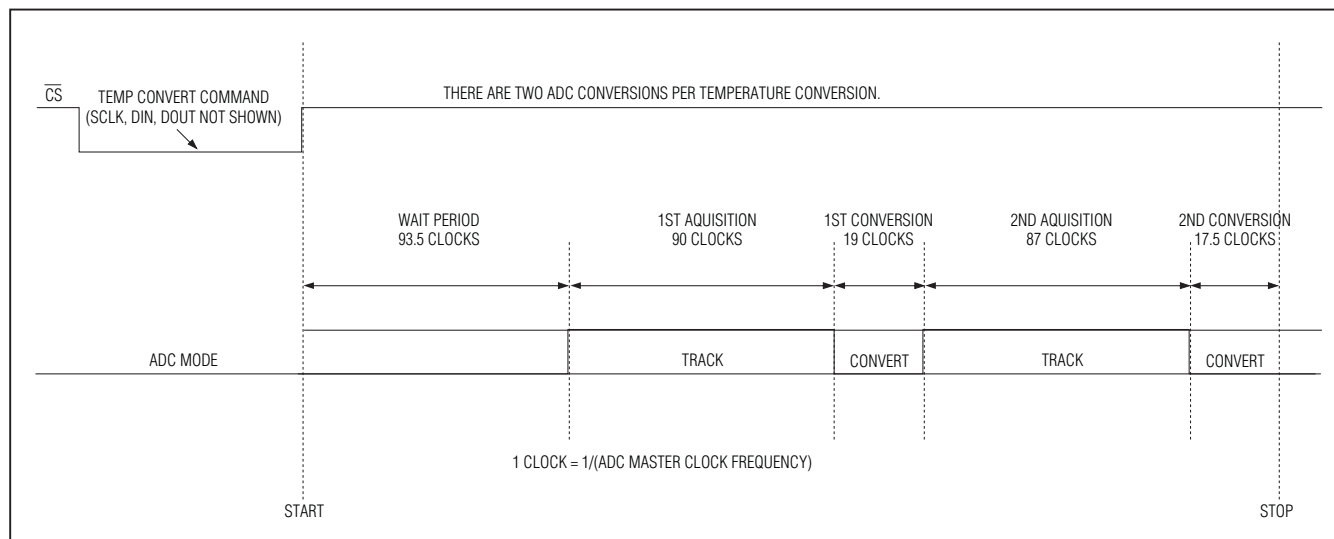

Figure 22. Temperature-Conversion Timing

See Figure 21 for performing an ADC conversion using a DPIO input programmed as CONVST. Allow at least 600ns for acquisition while the DPIO input is low and the acquisition ends on the rising edge of the DPIO. The conversion requires an additional 14 ADC clock cycles. If the PGA gain is set to 4 or 8, the minimum acquisition time is 1.2µs due to the increase of the input sampling capacitor.

Temperature Measurement

The MAX1329/MAX1330 perform temperature measurement by measuring the voltage across a diode-connected transistor at two different current levels. The following equation illustrates the algorithm used for temperature calculations:

$$\text{temperature} = (V_{\text{HIGH}} - V_{\text{LOW}}) \times \frac{\frac{q}{k}}{n \times \ln \left[\frac{I_{\text{HIGH}}}{I_{\text{LOW}}} \right]}$$

where:

V_{HIGH} = sensor-diode voltage with high current flowing (I_{HIGH})

V_{LOW} = sensor-diode voltage with low current flowing (I_{LOW})

q = charge of electron = 1.602 × 10⁻¹⁹ coulombs

k = Boltzman constant = 1.38 × 10⁻²³ J/K

n = ideality factor (slightly greater than 1)

The temperature measurement process is fully automated in the MAX1329/MAX1330. All steps are sequenced and executed by the MAX1329/MAX1330 each time an input channel (or an input channel pair) configured for temperature measurement is scanned.

The resulting 12-bit, two's complement number represents the sensor temperature in degrees Celsius, with 1 LSB = +0.125°C. Figure 22 shows the timing for a temperature measurement.

An external 2.500V reference can be applied to REFADJ, provided the internal reference is disabled first. Use the temperature correction equation to obtain the correct temperature:

$$T_{\text{ACT}} = 0.997 \times T_{\text{MEAS}} - 0.91^{\circ}\text{C}$$

Use the following equation when using the internal reference:

$$T_{\text{ACT}} = T_{\text{MEAS}} + (T_{\text{MEAS}} + 270.63) \times \left(1 - \frac{2.500\text{V}}{V_{\text{REFADJ}}}\right)^{\circ}\text{C}$$

12-/16-Bit DASs with ADC, DACs, DPIOs, APIOs, Reference, Voltage Monitors, and Temp Sensor

Register Definitions

Table 3. Register Summary

REGISTER NAME	START		READ/ WRITE (R/W)	ADDRESS (ADR<4:0>)				DATA (D<255:0>, D<23:0>, D<15:0>, OR D<7:0>)								
ADC Control	0	0	R/W	0	0	0	0	0	AUTO<2:0>		APD<1:0>		AREF<1:0>		REFE	
ADC Setup	0	0	R/W	0	0	0	0	1	MSEL	MUX<3:0>			GAIN<1:0>		BIP	
ADC Data	0	0	1	0	0	0	1	0	ADCDATA<11:0>			X	X	X	X	
ADC FIFO	0	0	0	0	0	0	1	1	AFFD<3:0>			AFFI<3:0>				
			1						AFFDATA<11:0>*			AFFA<3:0>*				
ADC Accumulator	0	0	0	0	0	1	0	0	DITH	ACCC<2:0>		X	X	X	X	
			1						ACCC<2:0>		ACCDATA<19:0>					
ADC GT Alarm	0	0	R/W	0	0	1	0	1	GTAM	GTAC<2:0>		GTAT<11:0>				
ADC LT Alarm	0	0	R/W	0	0	1	1	0	LTAM	LTAC<2:0>		LTAT<11:0>				
DAC Control	0	0	R/W	0	0	1	1	1	DAPD1	DAPD0/ OA3E	DBPD1	DBPD0/ OA2E	OA1E	DREF<1:0>		REFE
FIFOA Control	0	0	R/W	0	1	0	0	0	FFAE	BIPA	SYMA	CONA	DPTA<3:0>			
Reserved	0	0	X	0	1	0	0	1	RESERVED, DO NOT USE							
FIFOA Data	0	0	R/W	0	1	0	1	0	FFADATA<11:0>			X	X	X	X	
Reserved	0	0	X	0	1	0	1	1	RESERVED, DO NOT USE							
FIFO Sequence	0	0	W	0	1	1	0	0	X	X	X	X	X	X	X	
Clock Control	0	0	R/W	0	1	1	0	1	ODLY	OSCE	CLKIO<1:0>		ADDIV<1:0>		ACQCK<1:0>	
CP/VM Control	0	0	R/W	0	1	1	1	0	INTP	VM1<1:0>		VM2CP<2:0>		CPDIV<1:0>		
Switch Control	0	0	R/W	0	1	1	1	1	DSWA/ OSW3	DSWB	OSW1	OSW2	SPDT1<1:0>		SPDT2<1:0>	
APIO Control	0	0	R/W	1	0	0	0	0	AP4MD<1:0>		AP3MD<1:0>		AP2MD<1:0>		AP1MD<1:0>	
APIO Setup	0	0	R/W	1	0	0	0	1	AP4PU	AP3PU	AP2PU	AP1PU	AP4LL	AP3LL	AP2LL	AP1LL
DPIO Control	0	0	R/W	1	0	0	1	0	DP4MD<3:0>			DP3MD<3:0>				
									DP2MD<3:0>			DP1MD<3:0>				
DPIO Setup	0	0	R/W	1	0	0	1	1	DP4PU	DP3PU	DP2PU	DP1PU	DP4LL	DP3LL	DP2LL	DP1LL
Status	0	0	R	1	0	1	0	0	VM1A	VM1B	VM2	ADD	AFF	ACF	GTA	LTA
									APR<4:1>			APF<4:1>				
									DPR<4:1>			DPF<4:1>				
Interrupt Mask	0	0	R/W	1	0	1	0	1	MV1A	MV1B	MV2	MADD	MAFF	MACF	MGTA	MLTA
									MAPR<4:1>			MAPF<4:1>				
									MDPR<4:1>			MDPF<4:1>				
Reserved	0	0	X	1	0	1	1	0	RESERVED, DO NOT USE							
Reserved	0	0	X	1	0	1	1	1	RESERVED, DO NOT USE							
Reserved	0	0	X	1	1	0	0	0	RESERVED, DO NOT USE							

Note: R/W = 0 for write, R/W = 1 for read, X = don't care.

*Data length can vary from 1 to 16 words, where a word is 16 bits (12 data bits plus 4 address bits).

12-/16-Bit DASs with ADC, DACs, DPIOs, APIOs, Reference, Voltage Monitors, and Temp Sensor

Table 3. Register Summary (continued)

REGISTER NAME	START		READ/ WRITE (R/W)	ADDRESS (ADR<4:0>)					DATA (D<255:0>, D<23:0>, D<15:0>, OR D<7:0>)							
Reserved	0	0	X	1	1	0	0	1	RESERVED, DO NOT USE							
Reserved	0	0	X	1	1	0	1	0	RESERVED, DO NOT USE							
Reserved	0	0	X	1	1	0	1	1	RESERVED, DO NOT USE							
Reserved	0	0	X	1	1	1	0	0	RESERVED, DO NOT USE							
Reserved	0	0	X	1	1	1	0	1	RESERVED, DO NOT USE							
Reserved	0	0	X	1	1	1	1	0	RESERVED, DO NOT USE							
Reset	0	0	\bar{W}	1	1	1	1	1	X	X	X	X	X	X	X	X

Note: $R/\bar{W} = 0$ for write, $R/\bar{W} = 1$ for read, $X = \text{don't care}$.

*Data length can vary from 1 to 16 words, where a word is 16 bits (12 data bits plus 4 address bits).

Register Bit Descriptions

ADC Control Register

The ADC Control register configures the autoconvert mode, the ADC power-down modes, the ADC reference buffer, and the internal reference voltage. Changes made to the ADC Control register settings are applied immediately. If changes are made during a conversion in progress, discard the results of that conversion to ensure a valid conversion result.

AUTO<2:0>: ADC Autoconvert bits (default = 000). The AUTO<2:0> bits configure the ADC to continuously convert at the selected interval (see Table 4). Calculate the conversion rate by dividing the ADC master clock frequency by the selected number of clock cycles. For example, if the ADC master clock frequency is 3.6864MHz and the selected value is 256, the conversion rate is 3.6864MHz/256 or 14.4ksps. The conversion can be started with the ADC Direct Write command and runs continuously using the ADC master clock. Write 000 to the AUTO<2:0> bits to disable autoconvert mode. When the autoconvert ADC master clock cycle rate is set to 32 and the acquisition time is set to 32 (AUTO<2:0> = 001, ACQCK<1:0> = 11, and GAIN<1:0> = 1X), the acquisition time is automatically reduced to 16 clocks so that the ADC throughput is less than the autoconversion interval. The automode operation is unavailable in burst mode.

APD<1:0>: ADC Power-Down bits (default = 00). The APD<1:0> bits control the power-down states of the ADC and PGA (see Table 5). When a direct-mode ADC conversion command is received, the ADC and PGA power up except when APD<1:0> = 00.

The burst mode outputs data to DOUT directly in real time as the bit decision is made on the falling edge of SCLK and the latest conversion result is also stored in the ADC Data register. For this mode, the conversion rate is controlled by the SCLK frequency, which is limited to 5MHz. If the charge pump is enabled, synchronize SCLK with the CLKIO clock to prevent charge-pump noise from corrupting the ADC result. Initiate the conversion by writing to the ADC Control register. SCLK is required to run continuously during the conversion period. For ADC gains of 1 or 2, a total of 14 to 28 clocks (two to 16 for acquisition and 12 for conversion) are required to complete the conversion. For ADC gains of 4 or 8, a total of 16 to 44 clocks (four to 32 for acquisition, and 12 for conversion) are required to complete the conversion. Bringing \bar{CS} high aborts burst mode.

AREF<1:0>: ADC Reference Buffer bits (default = 00). The AREF<1:0> bits set the ADC reference buffer gain when REFE = 0 and the REFADC output voltage when REFE = 1 (see Table 6). Set AREF<1:0> to 00 to disable the ADC reference buffer and drive REFADC directly with an external reference.

REFE: Internal Reference Enable bit (default = 0). REFE = 1 enables the internal reference and sets REFADJ to 2.5V. REFE = 0 disables the internal reference, allowing an external reference to be applied at REFADJ, which drives the inputs to the ADC and DAC reference buffers. The voltage at REFADJ is also used for temperature measurement and must be 2.5V for accurate results. See the *Temperature Sensor* section. This bit is mirrored in the DAC Control register so that writing either location updates both bits.

	MSB					LSB		
NAME	AUTO2	AUTO1	AUTO0	APD1	APD0	AREF1	AREF0	REFE
DEFAULT	0	0	0	0	0	0	0	0

12-/16-Bit DASs with ADC, DACs, DPIOs, APIOs, Reference, Voltage Monitors, and Temp Sensor

Table 4. ADC Autoconvert Bit Configuration (AUTO<2:0>)

AUTO2	AUTO1	AUTO0	ADC MASTER CLOCK CYCLES
0	0	0	Autoconvert disabled
0	0	1	32
0	1	0	64
0	1	1	128
1	0	0	256
1	0	1	512
1	1	0	1024
1	1	1	2048

Table 5. ADC Power-Down Bit Configuration

APD1	APD0	ADC MODE	COMMENTS
0	0	Power-down	ADC/PGA off
0	1	Fast power-down	ADC/PGA off between conversions
1	0	Normal	ADC/PGA on
1	1	Burst	ADC/PGA on, SCLK clocks conversion, data clocked out on DOUT in real time on the falling edge of SCLK

Table 6. ADC Reference-Buffer Bit Configuration

AREF1	AREF0	ADC REFERENCE-BUFFER GAIN (V/V) (REFE = 0)	REFADC VOLTAGE (V) (REFE = 1)
0	0	Buffer off	High-impedance
0	1	0.5	1.25
1	0	0.8192	2.048
1	1	1	2.5

12-/16-Bit DASs with ADC, DACs, DPIOs, APIOs, Reference, Voltage Monitors, and Temp Sensor

ADC Setup Register

The ADC Setup register configures the input multiplexer, ADC gain, and unipolar/bipolar modes to perform a data conversion. Changes made to the ADC Setup register settings are applied immediately. If changes are made during a conversion in progress, discard the results of that conversion to ensure a valid conversion result.

MSEL: Multiplexer Select bit (default = 0). The MSEL bit selects the upper or lower multiplexer. MSEL = 0 selects the upper mux and MSEL = 1 selects the lower mux.

MUX<3:0>: Multiplexer Input Select bits (default = 0000). The MUX<3:0> bits plus the MSEL bit select the inputs to the ADC (see Tables 7 and 8).

GAIN<1:0>: ADC Gain bits (default = 00). The GAIN<1:0> bits select the gain of the ADC (see Table 9).

BIP: Unipolar-/Bipolar-Mode Selection bit (default = 0). For unipolar mode, set BIP = 0. For bipolar mode, set BIP = 1. For temperature-sensor conversions, use the default GAIN = 00 and BIP = 0.

MSB						LSB		
NAME	MSEL	MUX3	MUX2	MUX1	MUX0	GAIN1	GAIN0	BIP
DEFAULT	0	0	0	0	0	0	0	0

Table 7. Upper Multiplexer Bit Configuration (MSEL = 0)

MUX3	MUX2	MUX1	MUX0	POSITIVE INPUT		NEGATIVE INPUT	
				MAX1329	MAX1330	MAX1329	MAX1330
0	0	0	0	AIN1		AGND	
0	0	0	1	AIN2		AGND	
0	0	1	0	OUTA		AGND	
0	0	1	1	FBA		AGND	
0	1	0	0	OUT1		AGND	
0	1	0	1	IN1-		AGND	
0	1	1	0	OUTB	OUT2	AGND	
0	1	1	1	FBB	IN2-	AGND	
1	0	0	0	AIN1		AIN2	
1	0	0	1	AIN2		AIN1	
1	0	1	0	OUTA		FBA	
1	0	1	1	FBA		OUTA	
1	1	0	0	OUT1		IN1-	
1	1	0	1	IN1-		OUT1	
1	1	1	0	OUTB	OUT2	FBB	IN2-
1	1	1	1	FBB	IN2-	OUTB	OUT2

12-/16-Bit DASs with ADC, DACs, DPIOs, APIOs, Reference, Voltage Monitors, and Temp Sensor

MAX1329/MAX1330

Table 8. Lower Multiplexer Bit Configuration (MSEL = 1)

MUX3	MUX2	MUX1	MUX0	POSITIVE INPUT		NEGATIVE INPUT	
				MAX1329	MAX1330	MAX1329	MAX1330
0	0	0	0	AIN1		REFADC	
0	0	0	1	OUTA		REFADC	
0	0	1	0	OUT1		REFADC	
0	0	1	1	OUTB	OUT2	REFADC	
0	1	0	0	AIN1		REFDAC	
0	1	0	1	OUTA		REFDAC	
0	1	1	0	OUT1		REFDAC	
0	1	1	1	OUTB	OUT2	REFDAC	
1	0	0	0	TEMP1+ (Internal diode anode)		TEMP1- (Internal diode cathode)	
1	0	0	1	TEMP2+ (External diode anode at AIN1)		TEMP2- (External diode cathode at AIN2)	
1	0	1	0	TEMP3+ (External diode anode at AIN1)		AGND	
1	0	1	1	TEMP4+ (External diode anode at AIN2)		AGND	
1	1	0	0	DV _{DD} /4		AGND	
1	1	0	1	AV _{DD} /4		AGND	
1	1	1	0	REFADC		AGND	
1	1	1	1	REFDAC		AGND	

Table 9. ADC Gain Bit Configuration

GAIN1	GAIN0	ADC GAIN SETTING (V/V)
0	0	1
0	1	2
1	0	4
1	1	8

12-/16-Bit DASs with ADC, DACs, DPIOs, APIOs, Reference, Voltage Monitors, and Temp Sensor

ADC Data Register

The ADC Data register contains the result from the most recently completed analog-to-digital conversion. The 12-bit result is stored in the ADCDATA<11:0> bits. The data format is binary for unipolar mode and two's complement for bipolar mode. The ADC Data register contents are the same as the ADC FIFO contents at the last written address, unless writes to the ADC FIFO have been inhibited.

MSB								
NAME	ADCDATA11	ADCDATA10	ADCDATA9	ADCDATA8	ADCDATA7	ADCDATA6	ADCDATA5	ADCDATA4
DEFAULT	0	0	0	0	0	0	0	0
LSB								
NAME	ADCDATA3	ADCDATA2	ADCDATA1	ADCDATA0	X	X	X	X
DEFAULT	0	0	0	0	X	X	X	X

X = Don't care.

ADC FIFO Register

The ADC FIFO register contents are different for write and read modes. In write mode, the ADC FIFO register sets the working depth of the FIFO and the address that generates an interrupt. In read mode, the ADC FIFO register holds the ADC FIFO data and FIFO address.

Write Format

A serial interface write to the ADC FIFO register moves the FIFO write and read pointers to address 0.

AFFD<3:0>: ADC FIFO Depth bits (default = 0000). AFFD<3:0> sets the working depth of the FIFO (see Table 10). If set to a depth of zero, the ADC FIFO is disabled and writes to the AFF (ADC FIFO Full) bit in the Status register are also disabled. AFFD<3:0> are write-only bits.

AFFI<3:0>: ADC FIFO Interrupt Address bits (default = 0000). AFFI<3:0> sets the FIFO address. After each successful ADC conversion, the conversion results are transferred from the ADC Data register to the FIFO location indicated by the FIFO write pointer, and the FIFO write pointer is incremented. When the FIFO write pointer exceeds the value in AFFI<3:0>, the AFF bit in the Status register (Table 11) is asserted. Set the AFFI<3:0> value equal to or less than the AFFD<3:0> value. If set to a value greater than AFFD<3:0>, AFFI<3:0> is forced to the AFFD<3:0> value. If AFFD<3:0> is set to 0000 (depth of zero), the ADC FIFO is disabled and writes to the AFF bit are also disabled. AFFI<3:0> are write-only bits.

MSB					LSB			
NAME	AFFD3	AFFD2	AFFD1	AFFD0	AFFI3	AFFI2	AFFI1	AFFI0
DEFAULT	0	0	0	0	0	0	0	0

12-/16-Bit DASs with ADC, DACs, DPIOs, APIOs, Reference, Voltage Monitors, and Temp Sensor

Read Format

A single read from the ADC FIFO register returns the ADC FIFO data and the 4-bit FIFO address (AFFA<3:0>) corresponding to the location read.

After clocking out the 16-bit word, the read pointer increments and continual clock shifts out the 16-bit word at the location pointed to by the ADC FIFO read pointer. If trying to read from the ADC FIFO at a location pointed to by the ADC FIFO write pointer, the FIFO repeats the last ADC conversion result and corresponding ADC FIFO address equivalent to the ADC FIFO write pointer. To stop reading, bring \overline{CS} high after clocking out the 16th bit of a complete word. The read

pointer increments after each complete 16-bit word read. It does not increment if the read is aborted by bringing \overline{CS} high before clocking out all 16 bits. Any read operation on the ADC FIFO register resets the interrupt flag (AFF).

AFFDATA<11:0>: ADC FIFO Read Data bits (default = 0000 0000 0000). AFFDATA<11:0> returns the data written by the ADC at the current read pointer location.

AFFA<3:0>: ADC FIFO Read Address bits (default = 0000). AFFA<3:0> returns the address of the current read pointer location. AFFA<3:0> is never greater than the AFFD<3:0> programmed value.

MSB								
NAME	AFFDATA11	AFFDATA10	AFFDATA9	AFFDATA8	AFFDATA7	AFFDATA6	AFFDATA5	AFFDATA4
DEFAULT	0	0	0	0	0	0	0	0
LSB								
NAME	AFFDATA3	AFFDATA2	AFFDATA1	AFFDATA0	AFFA3	AFFA2	AFFA1	AFFA0
DEFAULT	0	0	0	0	0	0	0	0

Note: Data length can vary from 1 to 16 words, where a word is 16 bits (12 data bits plus 4 address bits).

Table 10. ADC FIFO Depth Bit Configuration

AFFD3	AFFD2	AFFD1	AFFD0	ADC FIFO WORD DEPTH	WRITE POINTER RANGE
0	0	0	0	FIFO disabled	
0	0	0	1	2	0-1
0	0	1	0	3	0-2
0	0	1	1	4	0-3
0	1	0	0	5	0-4
0	1	0	1	6	0-5
0	1	1	0	7	0-6
0	1	1	1	8	0-7
1	0	0	0	9	0-8
1	0	0	1	10	0-9
1	0	1	0	11	0-10
1	0	1	1	12	0-11
1	1	0	0	13	0-12
1	1	0	1	14	0-13
1	1	1	0	15	0-14
1	1	1	1	16	0-15

Table 11. ADC FIFO Interrupt-Address Bit Configuration

AFFI3	AFFI2	AFFI1	AFFI0	ADC FIFO INTERRUPT ADDRESS
0	0	0	0	0
0	0	0	1	1
0	0	1	0	2
0	0	1	1	3
0	1	0	0	4
0	1	0	1	5
0	1	1	0	6
0	1	1	1	7
1	0	0	0	8
1	0	0	1	9
1	0	1	0	10
1	0	1	1	11
1	1	0	0	12
1	1	0	1	13
1	1	1	0	14
1	1	1	1	15

12-/16-Bit DASs with ADC, DACs, DPIOs, APIOs, Reference, Voltage Monitors, and Temp Sensor

ADC Accumulator Register

The ADC Accumulator register contains the bits to enable dither, set the accumulator count, and set the 20-bit accumulator data. The dither and accumulator count bits are read/write and the accumulator data is read only. A write to the register resets the accumulator data (ACCDATA<19:0>) to 0x00000 and starts new accumulation. The ACCDATA<19:0> bits remain unchanged until the programmed count of conversions is completed. The accumulator is functional for the normal, fast power-down, and burst modes.

DITH: Dither bit (default = 0). When DITH = 0, the dither generator is disabled and the accumulator can be used for oversampling and providing digital filtering (see the *Applying a Digital Filter to ADC Data Using the 20-Bit Accumulator* section). When DITH = 1, the dithering for the ADC is enabled. Use dithering with the accumulator to oversample data and decimate the result to extend the

effective resolution to a maximum of 16 bits and provide digital filtering.

ACCC<2:0> ADC Accumulator Count bits (default = 000). The ACCC<2:0> bits set the number of ADC data conversion results to be accumulated and then written to the ACCDATA register before the ACF Status bit is set (see Table 12). The ACF status bit is set in the Status register when the data is written to the ACCDATA register. If the accumulator count is set to 1, the accumulator does not accumulate and the ACCDATA<11:0> is the same as ADCDATA<11:0> in the ADC Data register.

ACCDATA<19:0>: ADC Accumulator Data bits (default = 0x00000). The ACCDATA<19:0> bits are the summation of up to 256 ADC conversion results. When the count set by ACCC<2:0> has been reached, the ACF status bit is set and the accumulated data is written to this register. The data is written to the register at a rate of the ADC conversion rate divided by the accumulator count. The accumulator does not exceed 0xFFFFF.

Write Format

	MSB					LSB		
NAME	DITH	ACCC2	ACCC1	ACCC0	X	X	X	X
DEFAULT	0	0	0	0	X	X	X	X

X = Don't care.

Read Format

MSB								
NAME	DITH	ACCC2	ACCC1	ACCC0	ACCDATA19	ACCDATA18	ACCDATA17	ACCDATA16
DEFAULT	0	0	0	0	0	0	0	0
NAME	ACCDATA15	ACCDATA14	ACCDATA13	ACCDATA12	ACCDATA11	ACCDATA10	ACCDATA9	ACCDATA8
DEFAULT	0	0	0	0	0	0	0	0
LSB								
NAME	ACCDATA7	ACCDATA6	ACCDATA5	ACCDATA4	ACCDATA3	ACCDATA2	ACCDATA1	ACCDATA0
DEFAULT	0	0	0	0	0	0	0	0

Table 12. ADC Accumulator-Count Bit Configuration

ACCC2	ACCC1	ACCC0	ACCUMULATOR COUNT
0	0	0	1
0	0	1	4
0	1	0	8
0	1	1	16
1	0	0	32
1	0	1	64
1	1	0	128
1	1	1	256

12-/16-Bit DASs with ADC, DACs, DPIOs, APIOs, Reference, Voltage Monitors, and Temp Sensor

ADC GT Alarm Register

The ADC GT Alarm register contains the greater-than mode, trip count, and threshold settings. A write to this register address resets the trip counters to zero. The GT alarm is functional for the normal, fast power-down, and burst modes.

GTAM: ADC Greater-Than Alarm Mode bit (default = 0). GTAM = 0 means that the alarm trips do not need to be consecutive before the GTA Status bit is set. When GTAM = 1, the alarm trips must be consecutive to set the GTA Status bit.

GTAC<2:0>: ADC Greater-Than Alarm Trip Count bits (default = 000). GTAC<2:0> set the number of conversion

results needed to be greater than the alarm threshold before the GTA Status bit is set (see Table 13).

GTAT<11:0>: ADC Greater-Than Alarm Threshold bits (default = 0xFFF). When the required number of conversion results greater than the threshold set by the GTAT<11:0> bits have been completed, the GTA Status bit is set in the Status register. Clearing the GTA Status bit by reading the Status register or writing to the ADC GT Alarm register restarts the trip count. The GTAT<11:0> bits are in binary format when the ADC is in unipolar mode and two's complement format when the ADC is in bipolar mode. Disable the GT alarm by setting GTAT<11:0> to 0xFFF when the ADC is in unipolar mode and 0x7FF when the ADC is in bipolar mode.

MSB								
NAME	GTAM	GTAC2	GTAC1	GTAC0	GTAT11	GTAT10	GTAT9	GTAT8
DEFAULT	0	0	0	0	1	1	1	1
LSB								
NAME	GTAT7	GTAT6	GTAT5	GTAT4	GTAT3	GTAT2	GTAT1	GTAT0
DEFAULT	1	1	1	1	1	1	1	1

Table 13a. ADC Greater-Than Alarm Trip Count Bit Configuration

GTAC2	GTAC1	GTAC0	NUMBER OF TRIPS
0	0	0	1
0	0	1	2
0	1	0	3
0	1	1	4
1	0	0	5
1	0	1	6
1	1	0	7
1	1	1	8

12-/16-Bit DASs with ADC, DACs, DPIOs, APIOs, Reference, Voltage Monitors, and Temp Sensor

ADC LT Alarm Register

The ADC LT Alarm register contains the less-than mode, trip count, and threshold settings. Writing the register address resets the trip counters to zero. The LT alarm is functional for the normal, fast power-down, and burst modes.

LTAM: ADC Less-Than Alarm Mode bit (default = 0). LTAM = 0 means that the alarm trips need not be consecutive to cause the LTA Status bit to be set. LTAM = 1 means that the alarm trips must be consecutive before the LTA Status bit is set.

LTAC<2:0>: ADC Less-Than Alarm Trip Count bits (default = 000). LTAC<2:0> set the number of conversion results needed to be less than the alarm threshold before the LTA Status bit is set.

LTAT<11:0>: ADC Less-Than Alarm Threshold bits (default = 0x000). When the required number of ADC conversions results less than the threshold set by the LTAT<11:0> bits have been completed, the LTA Status bit is set in the Status register. Clearing the LTA Status bit by reading the Status register or writing to the ADC LT Alarm register restarts the trip count. The LTAT<11:0> bits are in binary format when the ADC is in unipolar mode and two's complement format when the ADC is in bipolar mode. Disable the LT alarm by setting LTAT<11:0> to 0x000 when the ADC is in unipolar mode and 0x800 when the ADC is in bipolar mode.

MSB								
NAME	LTAM	LTAC2	LTAC1	LTAC0	LTAT11	LTAT10	LTAT9	LTAT8
DEFAULT	0	0	0	0	0	0	0	0
LSB								
NAME	LTAT7	LTAT6	LTAT5	LTAT4	LTAT3	LTAT2	LTAT1	LTAT0
DEFAULT	0	0	0	0	0	0	0	0

Table 13b. ADC Less-Than Alarm Trip Count Bit Configuration

LTAC2	LTAC1	LTAC0	NUMBER OF TRIPS
0	0	0	1
0	0	1	2
0	1	0	3
0	1	1	4
1	0	0	5
1	0	1	6
1	1	0	7
1	1	1	8

12-/16-Bit DASs with ADC, DACs, DPIOs, APIOs, Reference, Voltage Monitors, and Temp Sensor

DAC Control Register

The DAC Control register configures the power states for DACA, DACB, the op amps, DAC reference buffer, and the internal reference. The DAC Control register also controls the DACA and DACB input and output register write modes. At power-up, all DACs and op amps are powered down. When powered down, the outputs of the DAC buffers and op amps are high impedance.

DAPD<1:0>: DACA Power-Down bits (default = 00). DAPD<1:0> control the power-down states and write modes for DACA (see Table 14).

DBPD<1:0>: (MAX1329 only) DACB Power-Down bits (default = 00). DBPD<1:0> control the power-down states and write modes for a DACB write as shown in Table 15.

OA1E: Op Amp 1 Enable bit (default = 0). Set OA1E = 1 to power up op amp 1.

OA2E (MAX1330 only): Op Amp 2 Enable bit (default = 0). Set OA2E = 1 to power up op amp 2.

DREF<1:0>: DAC Reference Buffer bits (default = 00). DREF<1:0> sets the DAC reference buffer gain when REFE = 0 (see Table 16). DREF<1:0> sets the REF DAC voltage when the REFE = 1.

REFE: Internal Reference Enable bit (default = 0). REFE = 1 enables the internal reference and sets REFADJ to 2.5V. REFE = 0 disables the internal reference so an external reference can be applied at REFADJ, which drives the inputs to the ADC and DAC reference buffers. This bit is mirrored in the ADC Control register so that writing either location updates both bits.

MAX1329								
MSB					LSB			
NAME	DAPD1	DAPD0	DBPD1	DBPD0	OA1E	DREF1	DREF0	REFE
DEFAULT	0	0	0	0	0	0	0	0

MAX1330								
MSB					LSB			
NAME	DAPD1	DAPD0	X	OA2E	OA1E	DREF1	DREF0	REFE
DEFAULT	0	0	X	0	0	0	0	0

Table 14. DACA Power-Down Bit Configuration

DAPD1	DAPD0	DACA POWER MODE	DACA WRITE MODE
0	0	Powered down	Write input and output register
0	1	Powered up	Write input and output register
1	0	Powered up	Write input register
1	1	Powered up	Shift input to output register

Table 15. DACB Power-Down Bit Configuration (MAX1329 Only)

DBPD1	DBPD0	DACB POWER MODE	DACB WRITE MODE
0	0	Powered down	Write input and output register
0	1	Powered up	Write input and output register
1	0	Powered up	Write input register
1	1	Powered up	Shift input to output register

12-/16-Bit DASs with ADC, DACs, DPIOs, APIOs, Reference, Voltage Monitors, and Temp Sensor

FIFOA Control Register

The FIFOA Control register enables the DACA FIFO, configures the bipolar, symmetry, and continuous modes, and sets the depth of the FIFO. Any change to the contents of this register resets the FIFOA sequence to the starting location. If the FIFO operation is enabled (FFAE = 1), the next sequence command transfers the DACA input register data to the output register. The DACA input or output register can be written to when the FIFO is enabled without affecting the FIFOA sequence, but the DACA output and/or input register data is changed.

FFAE: DACA FIFO Enable bit (default = 0). Set FFAE = 1 to enable the sequencing function. FFAE must be set to 0 to write to the FIFO. Writes to the FIFO when FFAE = 1 are ignored.

BIPA: DACA FIFO Bipolar bit (default = 0). Set BIPA = 0 to generate a unipolar waveform or set BIPA = 1 to generate a bipolar waveform. For a unipolar waveform, the FIFOA data is added to the DACA input register data during phases 1 and 2 (see Figures 8 and 9).

For a bipolar waveform, the FIFOA data is added to the DACA input register data (during phases 1 and 2) and

subtracted from the DACA input register data (during phases 3 and 4).

SYMA: DACA FIFO Symmetry bit (default = 0). Set SYMA = 0 to generate an asymmetrical waveform, consisting of phase 1 (BIPA = 0) or phases 1 and 4 (BIPA = 1). Set SYMA = 1 to generate symmetry phases 1 and 2 (BIPA = 0) or phases 1–4 (BIPA = 1).

CONA: DACA FIFO Continuous bit (default = 0). Set CONA = 0 to generate a single waveform or set CONA = 1 to generate a periodic or continuous waveform.

DPTA<3:0>: DACA FIFO Depth bits (default = 0000). The DPTA<3:0> bits set the depth of the FIFOA data register to be used for waveform generation (see Table 17). The entire FIFOA data register can be filled with 16 words but only the number programmed by DPTA<3:0> are used. During waveform generation, the FIFOA words are added to the DACA input register value before being sent to the DACA output register. The first output is the DACA input register value. The following value is the DACA input register value summed with the FIFOA location 1 value. The FIFOA locations are incremented until the FIFO depth specified by the DPTA<3:0> bits has been reached.

	MSB							LSB
NAME	FFAE	BIPA	SYMA	CONA	DPTA3	DPTA2	DPTA1	DPTA0
DEFAULT	0	0	0	0	0	0	0	0

Table 16. DAC Reference Buffer Bit Configuration

DREF1	DREF0	DAC REFERENCE BUFFER GAIN (V/V) (REFE = 0)	REFDAC VOLTAGE (V) (REFE = 1)
0	0	N/A	Buffer disabled
0	1	0.5	1.25
1	0	0.8192	2.048
1	1	1.0	2.5

12-/16-Bit DASs with ADC, DACs, DPIOs, APIOs, Reference, Voltage Monitors, and Temp Sensor

FIFOA Data Register

The FIFOA Data register stores up to 16 12-bit words that can be used by DACA to generate a waveform.

FFADATA<11:0>: FIFOA Data bits (default = 0xXXX). FFADATA<11:0> represents a 12-bit word that is left justified with 4 don't-care LSBs. A write or read operation always starts at location 1 and ends at the full FIFO depth. Any attempt to write past the full FIFO depth does not overwrite the data just written. Any attempt to read past the full FIFO depth returns zeroes on DOUT.

A write to the FIFOA Data register is possible only when the FFAE bit in the FIFOA Control register is 0. If FFAE = 1, any write to the FIFOA Data register is ignored. A read command is possible at any time. If BIPA = 0, the data is interpreted as binary (0 to 4095). If BIPA = 1, the data is interpreted as sign magnitude (-2047 to +2047). In sign magnitude, the MSB represents the sign bit, where 0 indicates a positive number and 1 indicates a negative number. The 11 LSBs provide the magnitude in sign magnitude.

MSB								
NAME	FFADATA11	FFADATA10	FFADATA9	FFADATA8	FFADATA7	FFADATA6	FFADATA5	FFADATA4
DEFAULT	0	0	0	0	0	0	0	0
LSB								
NAME	FFADATA3	FFADATA2	FFADATA1	FFADATA0	X	X	X	X
DEFAULT	0	0	0	0	X	X	X	X

X = Don't care.

Table 17. DACA FIFO Depth Bit Configuration

DPTA3	DPTA2	DPTA1	DPTA0	FIFOA DEPTH
0	0	0	0	1
0	0	0	1	2
0	0	1	0	3
0	0	1	1	4
0	1	0	0	5
0	1	0	1	6
0	1	1	0	7
0	1	1	1	8
1	0	0	0	9
1	0	0	1	10
1	0	1	0	11
1	0	1	1	12
1	1	0	0	13
1	1	0	1	14
1	1	1	0	15
1	1	1	1	16

12-/16-Bit DASs with ADC, DACs, DPIOs, APIOs, Reference, Voltage Monitors, and Temp Sensor

FIFO Sequence Register

A write to the FIFO Sequence register steps DACA to the next FIFOA word. A valid write consists of the 8-bit address and 8 bits of data, where the data bits are don't-care bits. The FIFO location increments on the 16th rising edge of SCLK. Successive writes sequence the entire contents of the FIFOA Data register to the DACA output register. The FIFO can also be sequenced with the DPIOs configured as DLDA or DLAB. The FIFO Sequence register is a write-only register.

Clock Control Register

The Clock Control register enables the internal oscillator and the CLKIO output, sets the ADC acquisition time, and controls the CLKIO, ADC, and charge-pump programmable dividers.

ODLY: Oscillator Turn-Off Delay bit (default = 0). Set ODLY = 0 to allow the oscillator to turn off immediately when powered down by the OSCE bit. If ODLY = 1, the oscillator turns off 1024 CLKIO clock cycles after it is powered down by the OSCE bit. ODLY also affects DPIO sleep mode (SLPB). When ODLY = 1, OSCE = 1, and CLKIO<1:0> does not equal 00b, SLPB is delayed by 1024 CLKIO clocks.

OSCE: Internal Oscillator Enable bit (default = 1). Set OSCE = 1 to enable the internal 3.6864MHz oscillator. Set OSCE = 0 to disable the internal oscillator and apply an external oscillator at CLKIO. When turning off, CLKIO drives low before becoming an input. **Do not leave CLKIO unconnected when configured as an input.** The APIOs and DPIOs can be configured as a wake-up to set the OSCE bit.

CLKIO<1:0>: CLKIO Configuration bits (default = 10). CLKIO<1:0> control the CLKIO input and output divider settings. See Table 18 for the CLKIO configurations. Changes to the CLKIO<1:0> bits occur on the falling edge of CLKIO. The ODLY bit is ignored and has no effect when the CLKIO is disabled. When OSCE = 1, changing the CLKIO output frequency does not change the frequency of the clock to the ADC and charge-pump clock dividers. When OSCE = 0, the output of the CLKIO input dividers is applied to the ADC and charge-pump clock dividers. The changes can take up to four CLKIO clock cycles due to internal synchronization.

ADDIV<1:0>: ADC Clock Divider bits (default = 00). ADDIV<1:0> configures the ADC clock divider (see Table 19), and the output is the ADC master clock (Figure 3). If OSCE = 1, the input to the ADC clock divider is the output of the 3.6864MHz oscillator. If OSCE = 0 and CLKIO<1:0> ≠ 00, the output of the CLKIO input divider is applied to the input of the ADC clock divider.

ACQCK<1:0>: ADC Acquisition Clock bits (default = 01). ACQCK<1:0> set the number of ADC master clocks used for the ADC acquisition (see Table 20). For gains of 1 or 2 (GAIN<1:0> = 0X in the ADC Control register), the number of acquisition clocks can be set for 2, 4, 8, or 16. For gains of 4 or 8 (GAIN<1:0> = 1X), the number of acquisition clocks can be programmed to be 4, 8, 16, or 32.

MSB					LSB			
NAME	ODLY	OSCE	CLKIO1	CLKIO0	ADDIV1	ADDIV0	ACQCK1	ACQCK0
DEFAULT	0	1	1	0	0	0	0	1

Table 18. CLKIO Bit Configuration

CLKIO1	CLKIO0	CLKIO INPUT MODE (OSCE = 0)	CLKIO OUTPUT MODE (MHz) (OSCE = 1)
0	0	Input	Disabled (output low)
0	1	$f_{CLKIO}/4$	1.2288
1	0	$f_{CLKIO}/2$	2.4567
1	1	f_{CLKIO}	4.9152

Table 19. ADC Clock Divider Bit Configuration

ADDIV1	ADDIV0	ADC CLOCK DIVIDER
0	0	Divide by 1
0	1	Divide by 2
1	0	Divide by 4
1	1	Divide by 8

12-/16-Bit DASs with ADC, DACs, DPIOs, APIOs, Reference, Voltage Monitors, and Temp Sensor

CP/VM Control Register

The CP/VM (Charge Pump/Voltage Monitor) Control register configures the interrupt polarity, charge-pump output voltage settings and power-down, supply voltage bypass switch state, and the voltage monitor settings for DVDD and AVDD.

INTP: Interrupt Polarity bit (default = 0). INTP controls the output polarity for $\overline{RST1}$ and $\overline{RST2}$ when configured as interrupt outputs. INTP = 0 results in active-low operation and INTP = 1 selects active-high operation.

VM1<1:0>: Voltage Monitor 1 (VM1) Control bits (default = 00). VM1 monitors the voltage on DVDD. The VM1<1:0> bits control the threshold and output settings of VM1 (see Table 21). $\overline{RST1}$ and $\overline{RST2}$ are open-drain outputs when configured as voltage monitor outputs and are push-pull when configured as interrupt outputs. The VM1A status bit is set when DVDD drops below the 1.8V threshold and the VM1B status bit is set when DVDD drops below the 2.7V threshold.

VM2CP<2:0>: Voltage Monitor 2 (VM2) and Charge-Pump Control bits (default = 000). VM2CP<2:0> control the charge pump, the bypass switch, and the AVDD voltage monitor. The charge pump generates a regulated AVDD supply voltage from a DVDD input. When activated (VM2CP = 100), the bypass switch internally shorts DVDD to AVDD. VM2 monitors the voltage on AVDD and sets the VM2 Status bit when AVDD drops below the threshold.

CPDIV<1:0>: Charge-Pump Clock Divider bits (default = 00). The CPDIV<1:0> bits set the divider value for the input clock to the charge pump (see Table 23). If OSCE = 1, the input to the charge-pump clock divider is the 3.6864MHz oscillator output. If OSCE = 0 and CLKIO<1:0> \neq 00, the output of the CLKIO input divider is applied to the input of the charge-pump clock divider. The charge pump is optimized to operate with a clock rate between 39kHz and 78kHz. Set the CPDIV<1:0> and CLKIO<1:0> bits to provide the optimal clock frequency for the charge pump.

	MSB						LSB	
NAME	INTP	VM11	VM10	VM2CP2	VM2CP1	VM2CP0	CPDIV1	CPDIV0
DEFAULT	0	0	0	0	0	0	0	0

Table 20. ADC Acquisition Clock Bit Configuration

ACQCK1	ACQCK0	ADC ACQUISITION CLOCKS	
		GAIN = 1, 2	GAIN = 4, 8
0	0	2	4
0	1	4	8
1	0	8	16
1	1	16	32

Table 21. Voltage Monitor 1 Control Bit Configuration

VM11	VM10	$\overline{RST1}$ OUTPUT	$\overline{RST2}$ OUTPUT	VM1A STATE (1.8V MONITOR)	VM1B STATE (2.7V MONITOR)
0	0	1.8V monitor	2.7V monitor	On	On
0	1	1.8V monitor	Interrupt	On	Off
1	0	Interrupt	2.7V monitor	Off	On
1	1	Interrupt	Interrupt	Off	Off

12-/16-Bit DASs with ADC, DACs, DPIOs, APIOs, Reference, Voltage Monitors, and Temp Sensor

Table 22. Voltage Monitor 2 and Charge-Pump Control Bit Configuration

VM2CP2	VM2CP1	VM2CP0	CHARGE-PUMP STATE	BYPASS SWITCH STATE	VM2 STATE (THRESHOLD VOLTAGE)
0	0	0	Off	Open	Off
0	0	1	On (3V)	Open	On (2.7V)
0	1	0	On (4V)	Open	On (3.8V)
0	1	1	On (5V)	Open	On (4.5V)
1	0	0	Off	Closed	Off
1	0	1	Off	Open	On (2.7V)
1	1	0	Off	Open	On (3.6V)
1	1	1	Off	Open	On (4.5V)

Table 23. Charge-Pump Clock Divider Bit Configuration

CPDIV1	CPDIV0	CHARGE-PUMP CLOCK DIVIDER
0	0	Divide by 32
0	1	Divide by 64
1	0	Divide by 128
1	1	Divide by 256

12-/16-Bit DASs with ADC, DACs, DPIOs, APIOs, Reference, Voltage Monitors, and Temp Sensor

Switch Control Register

The Switch Control register controls the two SPDT switches and the feedback switches for DACA, DACB, op amp 1, and op amp 2. The switches are controlled through the serial interface or by a configured DPIO.

DSWA: DACA Switch Control bit (default = 0). The DSWA bit controls the state of the DACA switch. A logic-high in DSWA or on any DPIO_ configured as a DACA switch control input causes the DACA switch to close. The switch remains open when DSWA = 0 and all DPIO_ pins configured as DACA switch control inputs are logic-low. DPIO_ pins not configured as DACA switch control inputs are treated as logic zeros. See Table 24.

DSWB (MAX1329 only): DACB Switch Control bit (default = 0). A logic-high in DSWB or an any DPIO_ configured as a DACB switch control input causes the DACB switch to close. The switch remains open when DSWB = 0 and all DPIO_s configured as DACB switch control inputs are logic-low. DPIO_s not configured as DACB switch control inputs are treated as logic zeros. See Table 25.

OSW1: Op Amp 1 Switch Control bit (default = 0). The OSW1 bit and DPIO_ configured in OSW1 mode control the state of the op amp 1 switch. If DPIO_ is not configured for OSW1 mode, it is set to 0 as shown in Table 26.

OSW2 (MAX1330 only): Op Amp 2 Switch Control bit (default = 0). The OSW2 bit and DPIO_ configured in OSW2 mode control the state of the op amp 2 switch. If DPIO_ is not configured for OSW2 mode, it is set to 0 as shown in Table 27.

SPDT1<1:0>: Single-Pole, Double-Throw Switch 1 (SPDT1) Control bits (default = 00). The SPDT1<1:0> bits and DPIO_ configured for SPDT1 mode control the state of the switch. If DPIO_ is not configured for SPDT1 mode, it is set to 0 as shown in Table 28.

SPDT2<1:0>: Single-Pole, Double-Throw Switch 2 (SPDT2) Control bits (default = 00). The SPDT2<1:0> bits and DPIO_ configured for SPDT2 mode control the state of the switch. If DPIO_ is not configured for SPDT2 mode, it is set to 0 as shown in Table 29.

MAX1329								
MSB					LSB			
NAME	DSWA	DSWB	OSW1	X	SPDT11	SPDT10	SPDT21	SPDT20
DEFAULT	0	0	0	X	0	0	0	0

MAX1330								
MSB					LSB			
NAME	DSWA	X	OSW1	OSW2	SPDT11	SPDT10	SPDT21	SPDT20
DEFAULT	0	X	0	0	0	0	0	0

X = Don't care.

Table 24. DACA Switch Control Configuration

DSWA BIT	DPIO4	DPIO3	DPIO2	DPIO1	DACA SWITCH STATE (DSWA)
0	0	0	0	0	Open
X	X	X	X	1	Closed
X	X	X	1	X	Closed
X	X	1	X	X	Closed
X	1	X	X	X	Closed
1	X	X	X	X	Closed

X = Don't care.

Table 25. DACB Switch Control Configuration

DSWB BIT	DPIO4	DPIO3	DPIO2	DPIO1	DACB SWITCH STATE (DSWB)
0	0	0	0	0	Open
X	X	X	X	1	Closed
X	X	X	1	X	Closed
X	X	1	X	X	Closed
X	1	X	X	X	Closed
1	X	X	X	X	Closed

X = Don't care.

12-/16-Bit DASs with ADC, DACs, DPIOs, APIOs, Reference, Voltage Monitors, and Temp Sensor

Table 26. Op Amp 1 Switch Control Configuration

OSW1 BIT	DPIO4	DPIO3	DPIO2	DPIO1	OP AMP 1 SWITCH STATE (OSW1)
0	0	0	0	0	Open
X	X	X	X	1	Closed
X	X	X	1	X	Closed
X	X	1	X	X	Closed
X	1	X	X	X	Closed
1	X	X	X	X	Closed

X = Don't care.

Table 27. Op Amp 2 Switch Control Configuration

OSW2 BIT	DPIO4	DPIO3	DPIO2	DPIO1	OP AMP 2 SWITCH STATE (OSW2)
0	0	0	0	0	Open
X	X	X	X	1	Closed
X	X	X	1	X	Closed
X	X	1	X	X	Closed
X	1	X	X	X	Closed
1	X	X	X	X	Closed

X = Don't care.

Table 28. SPDT1 Switch Control Configuration

SPDT11 BIT	SPDT10 BIT	DPIO4	DPIO3	DPIO2	DPIO1	SPDT1 SWITCH STATE	
						SNO1-TO-SCM1 STATE	SNC1-TO-SCM1 STATE
0	0	0	0	0	0	Open	Open
0	X	X	X	X	1	Closed	Closed
0	X	X	X	1	X	Closed	Closed
0	X	X	1	X	X	Closed	Closed
0	X	1	X	X	X	Closed	Closed
0	1	X	X	X	X	Closed	Closed
1	0	0	0	0	0	Open	Closed
1	X	X	X	X	1	Closed	Open
1	X	X	X	1	X	Closed	Open
1	X	X	1	X	X	Closed	Open
1	X	1	X	X	X	Closed	Open
1	1	X	X	X	X	Closed	Open

X = Don't care.

12-/16-Bit DASs with ADC, DACs, DPIOs, APIOs, Reference, Voltage Monitors, and Temp Sensor

Table 29. SPDT2 Switch Control Configuration

SPDT21 BIT	SPDT20 BIT	DPIO4	DPIO3	DPIO2	DPIO1	SPDT2 SWITCH STATE	
						SNO2-TO-SCM2 STATE	SNC2-TO-SCM2 STATE
0	0	0	0	0	0	Open	Open
0	X	X	X	X	1	Closed	Closed
0	X	X	X	1	X	Closed	Closed
0	X	X	1	X	X	Closed	Closed
0	X	1	X	X	X	Closed	Closed
0	1	X	X	X	X	Closed	Closed
1	0	0	0	0	0	Open	Closed
1	X	X	X	X	1	Closed	Open
1	X	X	X	1	X	Closed	Open
1	X	X	1	X	X	Closed	Open
1	X	1	X	X	X	Closed	Open
1	1	X	X	X	X	Closed	Open

APIO Control Register

The Analog Programmable Input/Output (APIO) Control register configures the modes of APIO1–APIO4. APIO1–APIO4 I/O logic levels are referenced to AV_{DD} and AGND (see Analog I/O in the *Electrical Characteristics* table). APIO_n is configurable as a general-purpose input,

active-low wake-up input, general-purpose output, or serial-interface, level-shifted buffered I/O.

AP_MD<1:0>: APIO_n Mode Configuration bits (default = 00). AP_MD<1:0> configures the APIO_n mode according to Table 30.

	MSB						LSB	
NAME	AP4MD1	AP4MD0	AP3MD1	AP3MD0	AP2MD1	AP2MD0	AP1MD1	AP1MD0
DEFAULT	0	0	0	0	0	0	0	0

Table 30. APIO_n Mode Bit Configuration

AP_MD1	AP_MD0	MODE	DESCRIPTION
0	0	GPI	Digital input. APIO _n logic level read from AP_LL register bit.
0	1	WUL	Digital input. A falling edge on APIO _n sets the OSCE bit to 1 enabling the oscillator.
1	0	GPO	Digital output. Set the APIO _n logic level by writing to the AP_LL register bit.
1	1	SPI	Digital input or output. The SPI mode functions differ for each APIO1–APIO4. <ul style="list-style-type: none"> • APIO1 digital input. DOUT outputs the APIO1 logic level when \overline{CS} is high, and APIO1 is a GPI, when \overline{CS} is low. Set the resistor pullup configuration with the AP1PU bit. • APIO2 digital output. APIO2 outputs the DIN logic level when \overline{CS} is high and becomes a GPO with the level set by AP2LL bit when \overline{CS} is low. • APIO3 digital output. APIO3 outputs the SCLK logic level when \overline{CS} is high and becomes a GPO with the level set by the AP3LL bit when \overline{CS} is low. • APIO4 digital output. APIO4 inverts and then outputs the \overline{CS} logic level.

12-/16-Bit DASs with ADC, DACs, DPIOs, APIOs, Reference, Voltage Monitors, and Temp Sensor

APIO Setup Register

The APIO Setup register programs the resistor pullup and the logic level for APIO1–APIO4.

AP<4:1>PU: APIO Resistor Pullup bits (default = 1111). AP_PU controls the internal 500k Ω (typ) pullup resistor on the corresponding APIO_. AP_PU = 0 disables the pullup resistor and AP_PU = 1 connects the pullup resistor to AV_{DD}. The pullup resistor is active only when the corresponding APIO_ is configured as an input.

AP<4:1>LL: APIO Logic-Level bits (default = 0000). If APIO_ is programmed as a GPO, set the corresponding AP_LL = 0 to set APIO_ to a logic-low level or set AP_LL = 1 to set APIO_ to a logic-high level. A read from AP_LL returns the logic level at the corresponding APIO_ when the register is read, regardless of the APIO mode.

MSB					LSB			
NAME	AP4PU	AP3PU	AP2PU	AP1PU	AP4LL	AP3LL	AP2LL	AP1LL
DEFAULT	1	1	1	1	0	0	0	0

DPIO Control Register

The Digital Programmable Input/Output (DPIO) Control register programs the modes of the DPIO1–DPIO4. DPIO1–DPIO4 are referenced to DV_{DD} and DGND (see Digital I/O in the *Electrical Characteristics* table).

DP_MD<3:0>: DPIO_ Mode Configuration bits (default = 0000). DP_MD<3:0> configures the corresponding DPIO_ (see Table 31).

MSB								LSB
NAME	DP4MD3	DP4MD2	DP4MD1	DP4MD0	DP3MD3	DP3MD2	DP3MD1	DP3MD0
DEFAULT	0	0	0	0	0	0	0	0
								LSB
NAME	DP2MD3	DP2MD2	DP2MD1	DP2MD0	DP1MD3	DP1MD2	DP1MD1	DP1MD0
DEFAULT	0	0	0	0	0	0	0	0

DPIO Setup Register

The DPIO Setup register configures the pullup resistor and logic level on DPIO1–DPIO4.

DP<4:1>PU: DPIO Resistor Pullup bits (default = 1111). DP_PU controls the internal 500k Ω (typ) pullup resistor on the corresponding DPIO_. DP_PU = 0 disables the pullup resistor and DP_PU = 1 connects the pullup resistor to DV_{DD}. The pullup resistor is active only when the corresponding DPIO_ is configured as an input.

DP<4:1>LL: DPIO Logic-Level bits (default = 0000). If DPIO_ is programmed as a GPO, set the corresponding DP_LL = 0 to set DPIO_ to a logic-low level or set DP_LL = 1 to set DPIO_ to a logic-high level. A read from DP_LL returns the logic level at the corresponding DPIO_ when the register is read, regardless of the DPIO mode.

MSB					LSB			
NAME	DP4PU	DP3PU	DP2PU	DP1PU	DP4LL	DP3LL	DP2LL	DP1LL
DEFAULT	1	1	1	1	0	0	0	0

12-/16-Bit DASs with ADC, DACs, DPIOs, APIOs, Reference, Voltage Monitors, and Temp Sensor

Table 31. DPIO_ Mode Bit Configuration

DP_MD3	DP_MD2	DP_MD1	DP_MD0	MODE		DESCRIPTION
				MAX1329	MAX1330	
0	0	0	0	GPI	GPI	Digital input. DPIO_ logic-level read from DP_LL register bit.
0	0	0	1	WUL	WUL	Digital input. A falling edge on WUL sets the OSCE bit enabling the oscillator.
0	0	1	0	WUH	WUH	Digital input. A rising edge on WUH sets the OSCE bit enabling the oscillator.
0	0	1	1	$\overline{\text{SLP}}$	$\overline{\text{SLP}}$	Digital input. A logic-low on $\overline{\text{SLP}}$ overrides the register settings and powers down all circuits except VM1 and all the registers. A logic-high on $\overline{\text{SLP}}$ transfers the power control back to the register settings. See the <i>Clock Control Register</i> section.
0	1	0	0	$\overline{\text{SHDN}}$	$\overline{\text{SHDN}}$	Digital input. A logic-low on $\overline{\text{SHDN}}$ overrides the register settings and powers down all circuits. A logic-high on $\overline{\text{SHDN}}$ transfers the power control back to the register settings.
0	1	0	1	DLAB	DLAB	Digital input. A rising edge on DLAB shifts DACA and DACB data from the input register to the output register or sequences through FIFOA if enabled. For the MAX1330, this applies only to DACA.
0	1	1	0	CONVST	CONVST	Digital input. CONVST controls acquisition time and conversion start. A falling edge on CONVST puts the ADC in acquisition mode. A rising edge on CONVST starts a single conversion.
0	1	1	1	DLDA	DLDA	Digital input. A rising edge on DLDA shifts DACA data from the input to output register or sequences through FIFOA if enabled.
1	0	0	0	DSWA	DSWA	Digital input. DSWA and OSW3 control the DACA and op amp 3 switches, respectively. See the <i>Switch Control Register</i> section.
1	0	0	1	DLDB	—	Digital input. A rising edge on DLDB shifts DACB data from the input to output register.
1	0	1	0	DSWB	OSW2	Digital input. DACB and op amp 2 control the DACB and op amp 2 switches, respectively. See the <i>Switch Control Register</i> section.
1	0	1	1	OSW1	OSW1	Digital input. Op amp 1 switch control. See the <i>Switch Control Register</i> section.
1	1	0	0	SPDT1	SPDT1	Digital input. SPDT1 controls the SPDT1 switch. See the <i>Switch Control Register</i> section.

12-/16-Bit DASs with ADC, DACs, DPIOs, APIOs, Reference, Voltage Monitors, and Temp Sensor

Table 31. DPIO_Mode Bit Configuration (continued)

DP_MD3	DP_MD2	DP_MD1	DP_MD0	MODE		DESCRIPTION
				MAX1329	MAX1330	
1	1	0	1	SPDT2	SPDT2	Digital input. SPDT2 controls the SPDT2 switch. See the <i>Switch Control Register</i> section.
1	1	1	0	DRDY	DRDY	Digital output. DRDY goes high when a conversion is complete and valid ADC data is available in the ADC Data register. If the ADC Data or Status register is read, DRDY returns low. If high, DRDY pulses low for one ADC master clock cycle while updating the ADC Data register before returning high.
1	1	1	1	GPO	GPO	Digital output. Write to the DP_LL register bits to set the GPO level.

Status Register

The Status register is a 24-bit register that contains Status bits from all blocks. Setting a Status bit causes the interrupt output to assert when the corresponding Interrupt Mask bit in the Interrupt Mask register is cleared. If a Status bit is set and an event occurs to set it again, the Status bit and interrupt output remain asserted. All Status bits clear once the Status register has been read successfully. Updating of the Status register is delayed during a read until the Status register read has been completed.

VM1A: 1.8V DV_{DD} Voltage-Monitor Status bit (default = 0). VM1A indicates the status of the 1.8V DV_{DD} voltage monitor. The VM1A = 1 when the DV_{DD} voltage drops below the 1.8V threshold. The VM1A bit clears to 0 when the Status register is read and only if the condition is no longer true. When the 1.8V DV_{DD} voltage monitor is powered down, the previous state of the bit is maintained until it is read and it cannot be set to 1 in this state.

Note: The default state is 0. However, at power-up, the voltage monitor asserts VM1A. Read the Status register after power-up to reset VM1A to 0.

VM1B: 2.7V DV_{DD} Voltage-Monitor Status bit (default = 0). VM1B indicates the status of the 2.7V DV_{DD} voltage monitor. VM1B = 1 when the DV_{DD} voltage drops below the 2.7V threshold. The VM1B bit clears to 0 when the Status register is read and only if the condition is no longer true. When the 2.7V DV_{DD} voltage monitor is powered down, the previous state of the bit is maintained until it is read and it cannot be set to 1 in this state.

Note: The default state is 0. However, at power-up, the voltage monitor asserts VM1B. Read the Status register after power-up to reset VM1B to 0.

VM2: AV_{DD} Voltage-Monitor Status bit (default = 0). VM2 indicates the status of the AV_{DD} voltage monitor. VM2 = 1 when the AV_{DD} voltage drops below the threshold programmed by the VM2CP<2:0> bits. VM2 clears to 0 when the Status register is read and only if the condition is no longer true. When the AV_{DD} voltage monitor is powered down, the previous state of the bit is maintained until it is read and it cannot be set to 1 in this state.

ADD: ADC Done Status bit (default = 0). The ADD bit indicates when an ADC conversion has completed and the data is ready to be read from the ADC Data register. ADD is set to 1 after the data from an ADC conversion has been written to the ADC Data register. ADD clears to 0 when the Status register or the ADC Data register is read.

AFF: ADC FIFO Full Status bit (default = 0). The AFF bit indicates that the ADC has written data to the ADC FIFO address programmed by the AFFI<3:0> bits. The AFF bit is set to 1 when the address has been written. AFF clears to 0 when the Status register is read or when the ADC FIFO register is read (any number of ADC data words) or written.

ACF: ADC Accumulator Full Status bit (default = 0). The ACF bit indicates that the programmed number of ADC conversion results have been accumulated. The result is saved in the ACCDATA<19:0> bits in the ADC Accumulator register for the next programmed number of accumulations before it is overwritten. The ACF bit sets to 1 when the ADC Accumulator is filled to the programmed address. The ACF bit clears to 0 when the Status register is read or when the ADC Accumulator register is read or written.

12-/16-Bit DASs with ADC, DACs, DPIOs, APIOs, Reference, Voltage Monitors, and Temp Sensor

MSB								
NAME	VM1A	VM1B	VM2	ADD	AFF	ACF	GTA	LTA
DEFAULT	0*	0*	0	0	0	0	0	0
NAME	APR4	APR3	APR2	APR1	APF4	APF3	APF2	APF1
DEFAULT	0	0	0	0	0	0	0	0
LSB								
NAME	DPR4	DPR3	DPR2	DPR1	DPF4	DPF3	DPF2	DPF1
DEFAULT	0	0	0	0	0	0	0	0

*The default states for VM1A and VM1B are 0. However, at power-up, the voltage monitor asserts VM1A and VM1B.

GTA: ADC Greater-Than (GT) Alarm Status bit (default = 0). GTA = 1 indicates that ADC GT alarm has been tripped. The GTA bit clears to 0 by reading the Status register or by writing the ADC GT Alarm register.

LTA: ADC Less-Than (LT) Alarm Status bit (default = 0). LTA = 1 indicates that the ADC LT alarm has been tripped. The LTA bit clears to 0 by reading the Status register or by writing the ADC LT Alarm register.

APR<4:1>: APIO Rising-Edge Status bit (default = 0). A logic-high in the APR<4:1> bits indicate that a rising edge has been detected on the corresponding APIO_. APR_ clears to 0 when the Status register is read.

APF<4:1>: APIO Falling-Edge Status bit (default = 0). A logic-high in the APF<4:1> bits indicate that a falling edge has been detected on the corresponding APIO_. APF_ clears to 0 when the Status register is read.

DPR<4:1>: DPIO Rising-Edge Status bit (default = 0). A logic-high in the DPR<4:1> bits indicate that a rising edge has been detected on the corresponding DPIO_. DPR_ clears to 0 when the Status register is read.

DPF<4:1>: DPIO Falling-Edge Status bit (default = 0). A logic-high in the DPF<4:1> bits indicate that a falling edge has been detected on the corresponding DPIO_. DPF_ clears to 0 when the Status register is read.

12-/16-Bit DASs with ADC, DACs, DPIOs, APIOs, Reference, Voltage Monitors, and Temp Sensor

Interrupt Mask Register

The Interrupt Mask register bits enable the Status bits to generate an interrupt on $\overline{RST1}$ and/or $\overline{RST2}$ if programmed as interrupts (configured by VM1<1:0> in the CP/VM Control register). Clearing a mask bit to 0 enables the corresponding bit in the Status register to generate an interrupt. Setting a mask bit to 1 prevents the Status bit from generating an interrupt. If the interrupt output is asserted and another interrupt occurs, the interrupt output remains asserted. Interrupt conditions on $\overline{RST1}$ and/or $\overline{RST2}$ are released after recognizing a read to the Status register. Updating of the Status register is delayed until after the Status register has been read. If the Status register read was aborted or if a new unmasked Status bit is set during the read, the interrupt output reasserts at the end of the read (see Figure 15).

MV1A: 1.8V DV_{DD} Voltage-Monitor Mask bit (default = 1). Set MV1A = 0 to unmask the VM1A Status bit to generate an interrupt.

MV1B: 2.7V DV_{DD} Voltage-Monitor Mask bit (default = 1). Set MV1B = 0 to unmask the VM1B Status bit to generate an interrupt.

MVM2: AV_{DD} Voltage-Monitor Mask bit (default = 1). Set MVM2 = 0 to unmask the VM2 Status bit to generate an interrupt.

MADD: ADC Done Mask bit (default = 1). Set MADD = 0 to unmask the ADD Status bit to generate an interrupt.

MAFF: ADC FIFO Full Mask bit (default = 1). Set MAFF = 0 to unmask the AFF Status bit to generate an interrupt.

MACF: ADC Accumulator Full Mask bit (default = 1). Set MACF = 0 to unmask the MACF Status bit to generate an interrupt.

MGTA: ADC GT Alarm Mask bit (default = 1). Set MGTA = 0 to unmask the GTA Status bit to generate an interrupt.

MLTA: ADC LT Alarm Mask bit (default = 1). Set MLTA = 0 to unmask the LTA Status bit to generate an interrupt.

MAPR<4:1>: APIO Rising-Edge Mask bits (default = 1111). Set MAPR_ = 0 to unmask the corresponding APIO_ Status bit to generate an interrupt.

MAPF<4:1>: APIO Falling-Edge Mask bits (default = 1111). Set MAPF_ = 0 to unmask the corresponding APIO_ Status bit to generate an interrupt.

MDPR<4:1>: DPIO Rising-Edge Mask bits (default = 1111). Set MDPR_ = 0 to unmask the corresponding DPIO_ Status bit to generate an interrupt.

MDPF<4:1>: DPIO Falling-Edge Mask bits (default = 1111). Set MDPF_ = 0 to unmask the corresponding DPIO_ Status bit to generate an interrupt.

Reset Register

A write to the Reset register resets all registers to their default values. A valid write consists of the 8-bit address and 8 don't-care bits of data. The reset occurs on the 16th rising edge of SCLK.

MSB								
NAME	MV1A	MV1B	MVM2	MADD	MAFF	MACF	MGTA	MLTA
DEFAULT	1	1	1	1	1	1	1	1
NAME	MAPR4	MAPR3	MAPR2	MAPR1	MAPF4	MAPF3	MAPF2	MAPF1
DEFAULT	1	1	1	1	1	1	1	1
LSB								
NAME	MDPR4	MDPR3	MDPR2	MDPR1	MDPF4	MDPF3	MDPF2	MDPF1
DEFAULT	1	1	1	1	1	1	1	1

12-/16-Bit DASs with ADC, DACs, DPIOs, APIOs, Reference, Voltage Monitors, and Temp Sensor

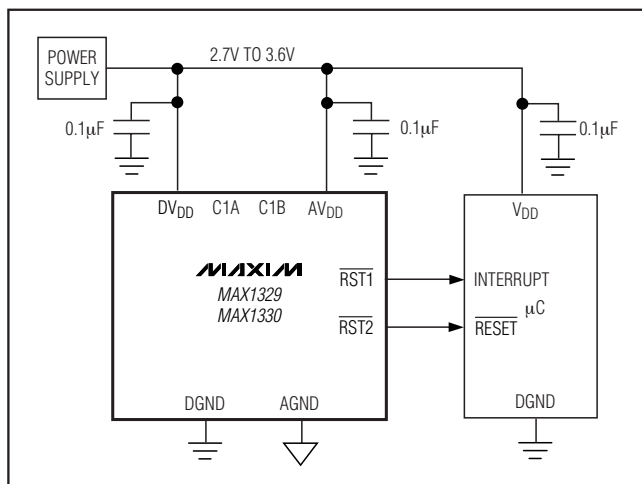

Figure 23. Power-Supply Circuit Using an External 3.0V Power Supply for DV_{DD} and AV_{DD}

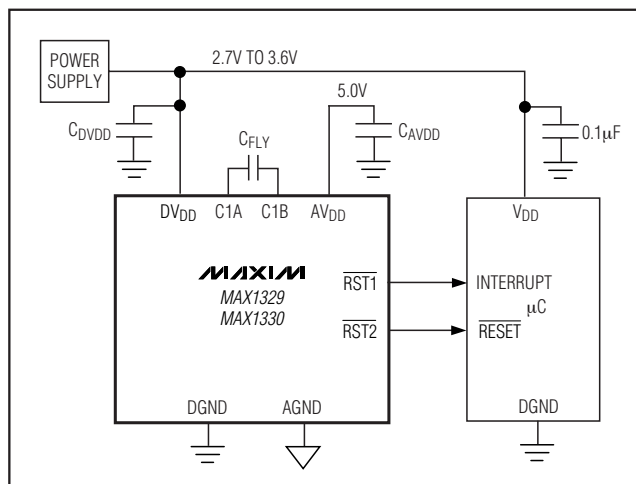

Figure 24. Power-Supply Circuit Using an External 3.0V Power Supply for DV_{DD} and Internal Charge Pump Set to 5V for AV_{DD}

Applications Information

Power-Supply Considerations

The circuit in Figure 23 applies an external 3.0V power supply to both DV_{DD} and AV_{DD}. To drive AV_{DD} directly, disable the internal charge pump through the CP/V_M Control register. The bypass switch between DV_{DD} and AV_{DD} can be either open or closed in this configuration.

Figure 24 shows the charge pump enabled to supply AV_{DD}. The charge-pump output voltage is set to 5.0V through the CP/V_M Control register. See the *Charge-Pump Component Selection* section.

Figure 25 shows DV_{DD} is powered from a battery with the charge-pump output set to 3.0V. The charge pump can draw high peak currents from DV_{DD} under maximum load. Select an appropriately sized bypass capacitor for DV_{DD} (≥ 10 times C_{FLY}). Supply ripple can be reduced by increasing C_{AVDD} and/or the charge-pump clock frequency.

Running Directly Off Batteries

The MAX1329/MAX1330 can be powered directly from two alkaline cells, two silver oxide button cells, or a lithium-coin cell. DV_{DD} requires 1.8V to 3.6V and AV_{DD} requires 2.7V to 5.5V for proper operation. Save power by running DV_{DD} directly off the battery and shorting to AV_{DD} by closing the internal bypass switch. Use the 2.7V AV_{DD} voltage monitor to detect when it drops to 2.7V. Power is saved during this time because the internal charge pump is off. Once the battery voltage drops to 2.7V, open the bypass switch and enable the internal charge pump as long as DV_{DD} is between 1.8V and 2.7V. Following this procedure optimizes the battery life.

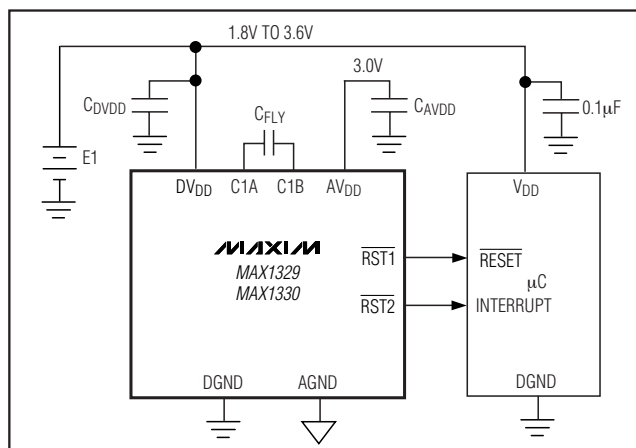

Figure 25. Power-Supply Circuit Using a Battery for DV_{DD} and Internal Charge Pump Set to 3.0V for AV_{DD}

Digital-Interface Connections

Figure 26 provides standard digital-interface connections between the MAX1329/MAX1330 and a µC. The µC generates its own 32kHz clock for timekeeping and the MAX1329/MAX1330 provide the high-frequency clock required by the µC. See the *Clock Control Register* section to program the CLKIO output and frequency and set the ODLY bit to delay the turn-off time to enable the µC time to go to sleep. During sleep, CLKIO becomes an input and requires a weak pulldown resistor ($\leq 1M\Omega$) to minimize power dissipation. See the DPIO Setup and DPIO Control registers to program DPIO1–DPIO4 as wake-ups. Upon wake-up, the internal oscillator starts and outputs to CLKIO. See the *CP/V_M Control Register* section to program the RST1 and RST2 as a reset or interrupt.

12-/16-Bit DASs with ADC, DACs, DPIOs, APIOs, Reference, Voltage Monitors, and Temp Sensor

Communication with a Peripheral Device Powered by the MAX1329/MAX1330

The circuit in Figure 27 shows the MAX1329/MAX1330 providing an interface between a μC and a peripheral device powered by different supply voltages. This eliminates the need for external level-translation circuitry due to the different supply voltages. The internal charge pump boosts the μC supply voltage (DV_{DD}) to the peripheral device supply voltage (AV_{DD}). See the APIO Control and APIO Setup registers to program APIO2–APIO4 as DIN, SCLK, and $\overline{\text{CS}}$ outputs to the peripheral device, respectively, and APIO1 as the DOUT input from the peripheral device. The digital inputs at DIN, SCLK, and $\overline{\text{CS}}$ are level-translated from DV_{DD} to AV_{DD} and output at the configured APIO2, APIO3, and APIO4 outputs. The digital output at DOUT is level-translated from AV_{DD} to DV_{DD} from the configured APIO1 input.

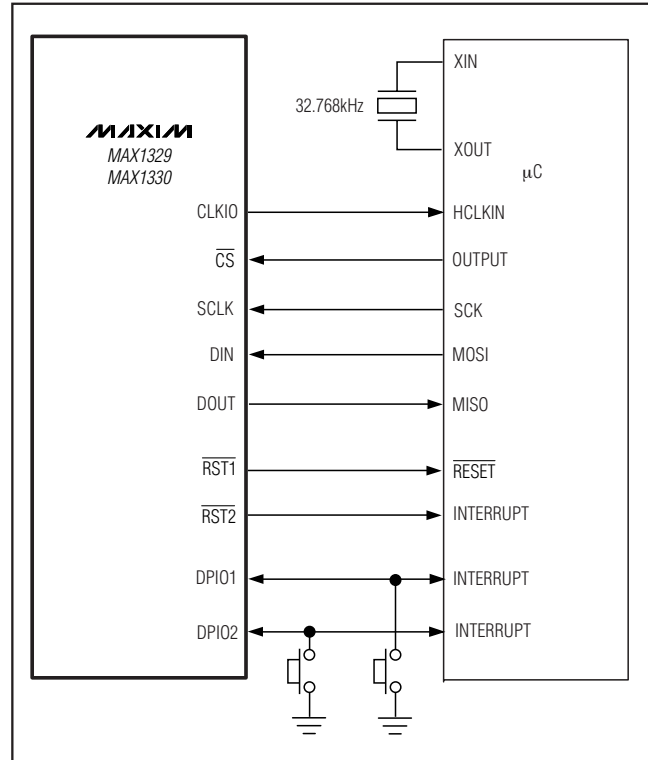

Figure 26. Digital-Interface Connections

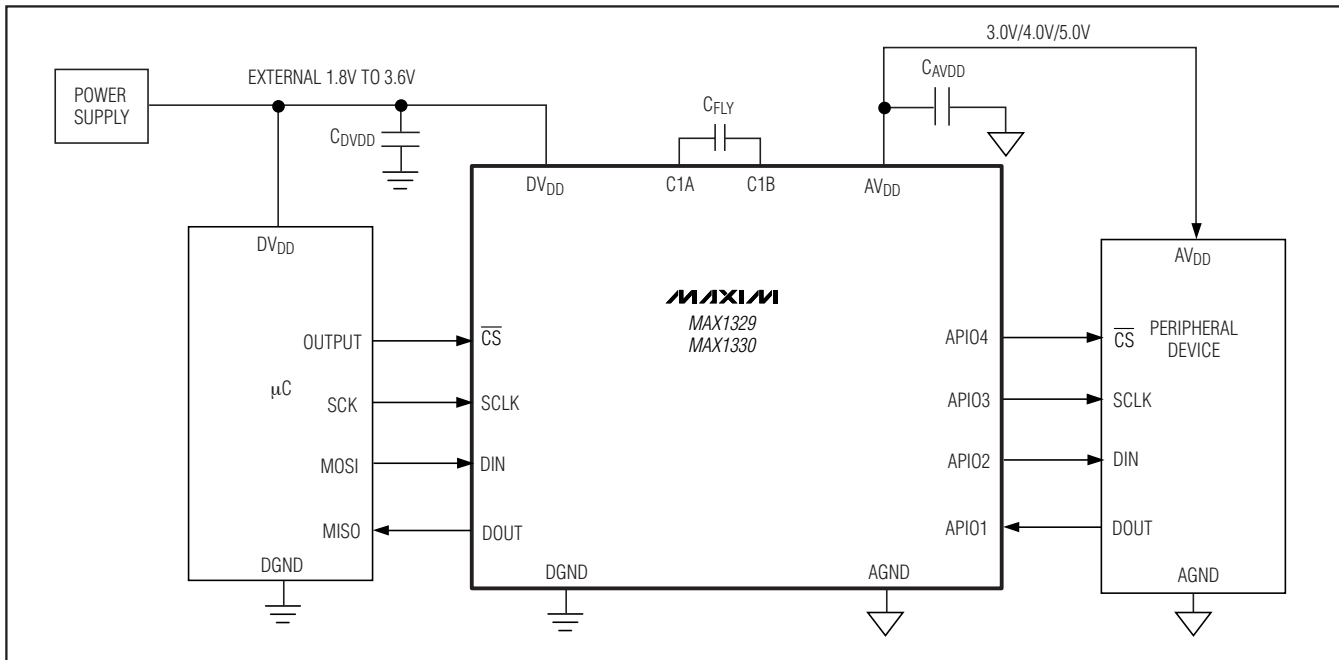

Figure 27. Communication with a Peripheral Device Powered by the MAX1329/MAX1330

12-/16-Bit DASs with ADC, DACs, DPIOs, APIOs, Reference, Voltage Monitors, and Temp Sensor

MAX1329/MAX1330

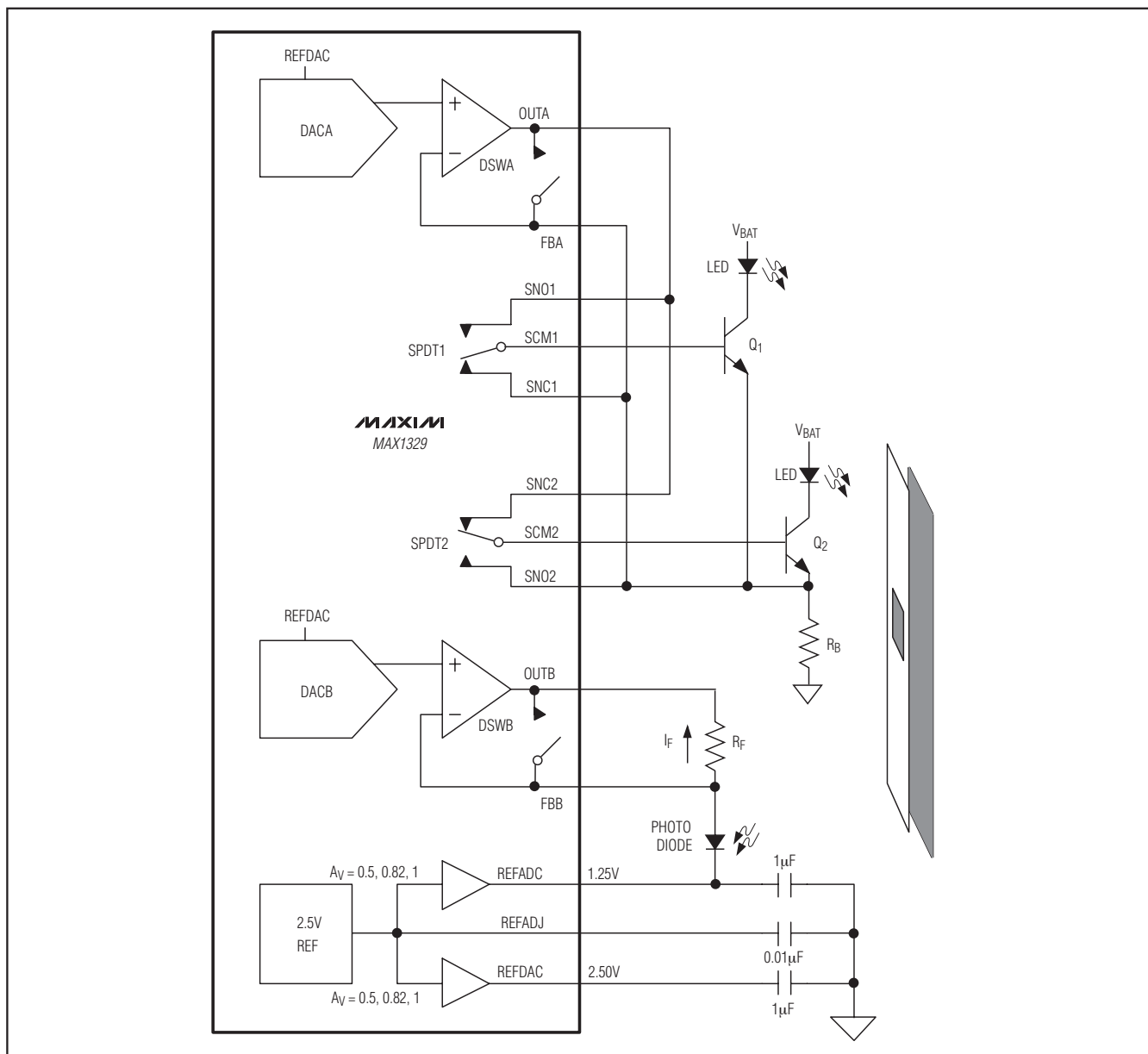

Figure 28. Optical Reflectometry Application with Dual LED and Single Photodiode

Optical Reflectometry Application with Dual LED and Single Photodiode

Figure 28 illustrates the MAX1329 in an optical reflectometry application with two transmitting LEDs and one receiving photodiode. The LEDs transmit light at specific frequencies onto the sample strip and the photodiode receives the reflections from the strip. Set the DACA output to provide the appropriate bias currents for the LEDs.

The DSWA and DSWB switches are open in this configuration. The LED bias current is calculated as $I_{LED} = V_{OUTA}/R_B$. REFADC is used as an analog ground and DACB is set to ensure that the photodiode is not forward biased. The I_F current is converted to a voltage through the R_F resistor and measured by the internal ADC. SPDT1 and SPDT2 are configured as single-pole double-throw switches and enable switching between

12-/16-Bit DASs with ADC, DACs, DPIOs, APIOs, Reference, Voltage Monitors, and Temp Sensor

the two LEDs. The LEDs can be powered directly from V_{BAT} or from AV_{DD} powered by the internal charge pump if the V_D of the LEDs require a higher or regulated voltage. Ambient light rejection is performed in the digital domain in this configuration by digitizing the photodiode current with the internal ADC while both LEDs are off and subtracting this from the result when the LEDs are turned on.

Three-Electrode Potentiostat with Software-Switchable Single- or Dual-Channel Connection

The MAX1329 is used in a software switchable single- or dual-channel three-electrode potentiostat application (see Figure 29). In both configurations, the DAC buffer feedback switches, DSWA and DSWB, are normally open but can be closed during high sensor current to keep the DAC buffer outputs compliant. In the dual-channel configuration, the SPDT1 switch is open and the OSW1 switch is closed. DACA biases the working electrode (WE) and DACB biases the reference electrode (RE) both relative to the counter electrode (CE). The CE is shared by the two channels. In this configuration, RE is really a second working electrode and I_A and I_B are the two sensor currents being measured. I_A and I_B are converted to voltages through R_A and R_B and measured by the internal ADC. In the single-channel configuration, the SPDT1 switch is closed and the OSW1 switch is open. DACA biases the WE relative to the RE and the RE is set by IN1-. Op amp 1's force-sense configuration holds RE constant while the CE swings up and down depending on the sensor current and the sensor impedance. In this configuration, I_A is the sensor current being measured. The R₁ resistor is typically a large value to keep op amp 1 stable when the sensor is not present or not active.

Two-Electrode Potentiostat with AC and DC Excitation

The circuit in Figure 30 shows the MAX1330 in a two-electrode potentiostat application with both AC and DC excitation to the sensor. The DSWA can be open or closed and OSW1 and OSW2 should be normally open although OSW1 can be closed during high sensor current to keep op amp 1 in compliance. REFADC is analog ground and the working electrode (WE) is connected to analog ground through op amp 1. The sensor current to be measured is converted to a voltage through R_F and measured by the internal ADC. For DC operation, the bias voltage between WE and the counter electrode (CE) is set by DACA. For AC operation, DACA is configured to generate a waveform by programming the FIFOA Control and FIFOA Data registers for the desired operation. Op amp 2 is configured as a 2nd-order Sallen Key lowpass filter to smooth the steps in the AC waveform going to the sensor. The DACA can be sequenced to create an AC waveform through the SPI interface or by configuring one of the DPIOs and driving it with a clock. The internal ADC includes a 16-word FIFO to facilitate data gathering during this mode of operation.

Temperature Measurement with Two Remote Sensors

For external measurements, select single-ended AIN1 and AIN2 temperature measurement relative to AGND in the lower multiplexer. Two diode-connected 2N3904 transistors are used as external temperature sensing diodes in Figure 31. For internal temperature sensor measurements, select internal temperature measurement in the lower multiplexer. During all temperature measurements, autoconvert and burst modes are unavailable. Divide the ADC result by eight to obtain the measured temperature.

When using an external reference at REFADJ, disable the internal reference and use the temperature correction equation in the *Temperature Measurement* section.

12-/16-Bit DASs with ADC, DACs, DPIOs, APIOs, Reference, Voltage Monitors, and Temp Sensor

MAX1329/MAX1330

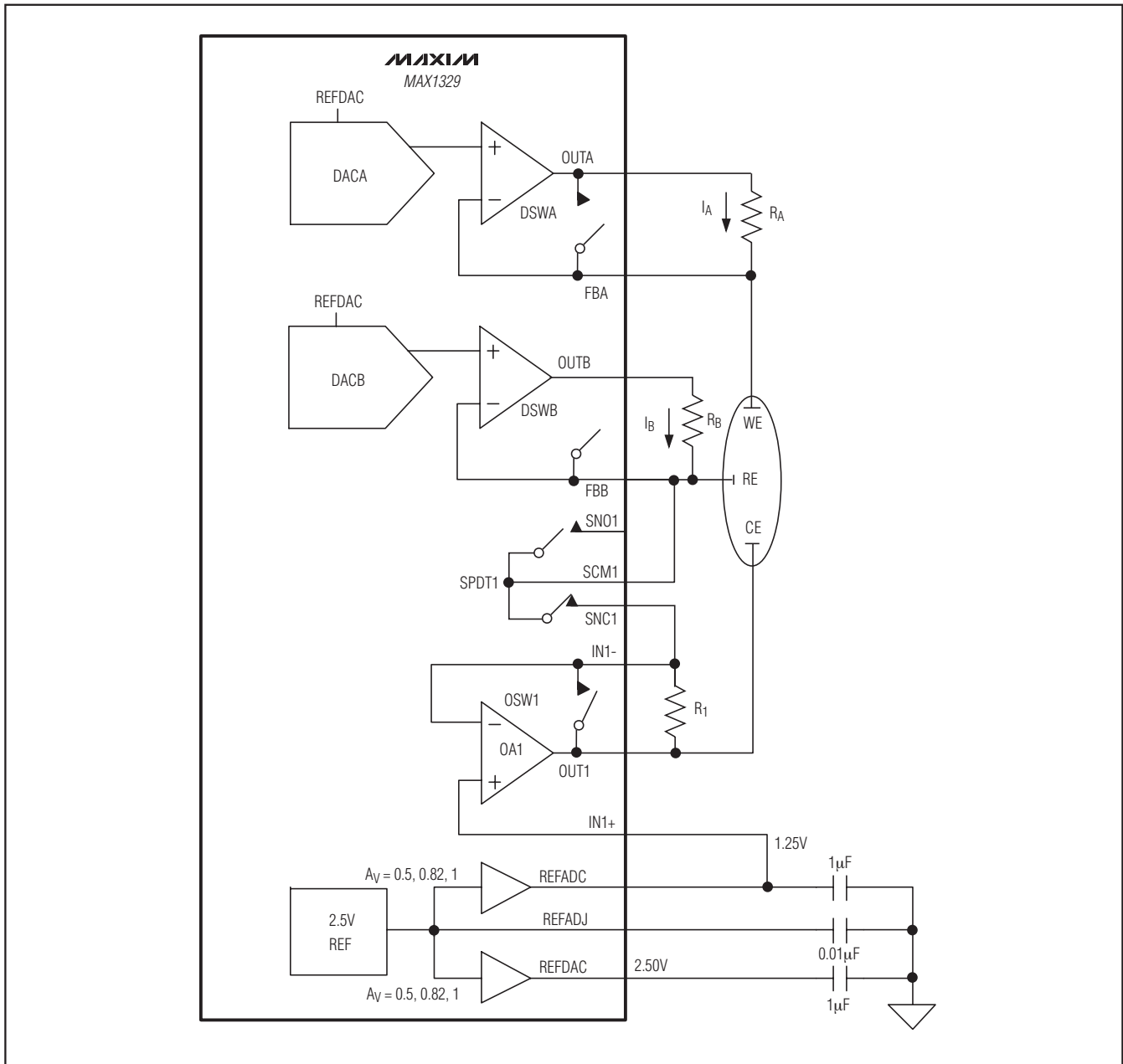

Figure 29. Three-Electrode Potentiostat Software-Switchable Single- or Dual-Channel Connection

12-/16-Bit DASs with ADC, DACs, DPIOs, APIOs, Reference, Voltage Monitors, and Temp Sensor

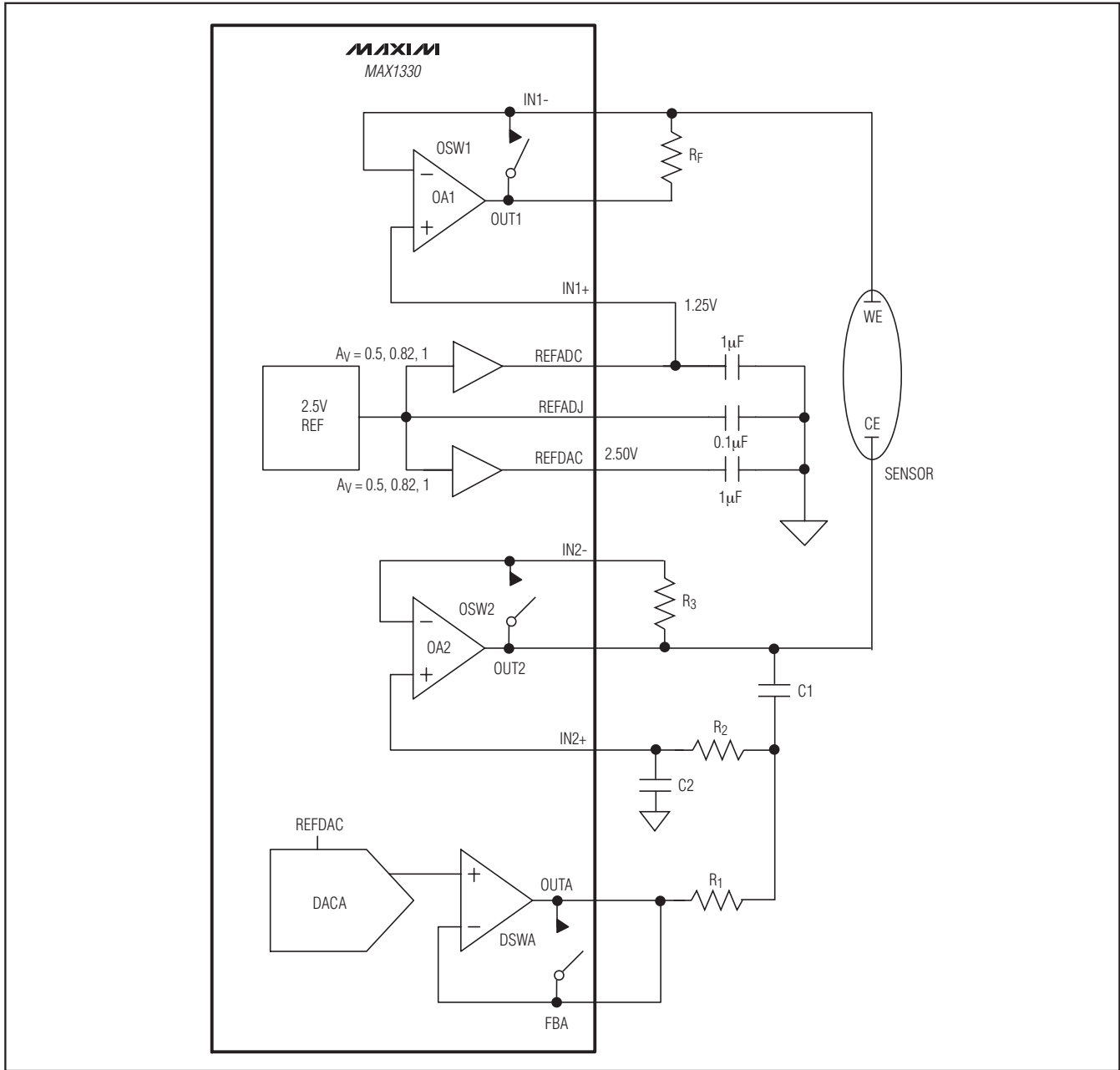

Figure 30. Two-Electrode Potentiostat with AC and DC Excitation

12-/16-Bit DASs with ADC, DACs, DPIOs, APIOs, Reference, Voltage Monitors, and Temp Sensor

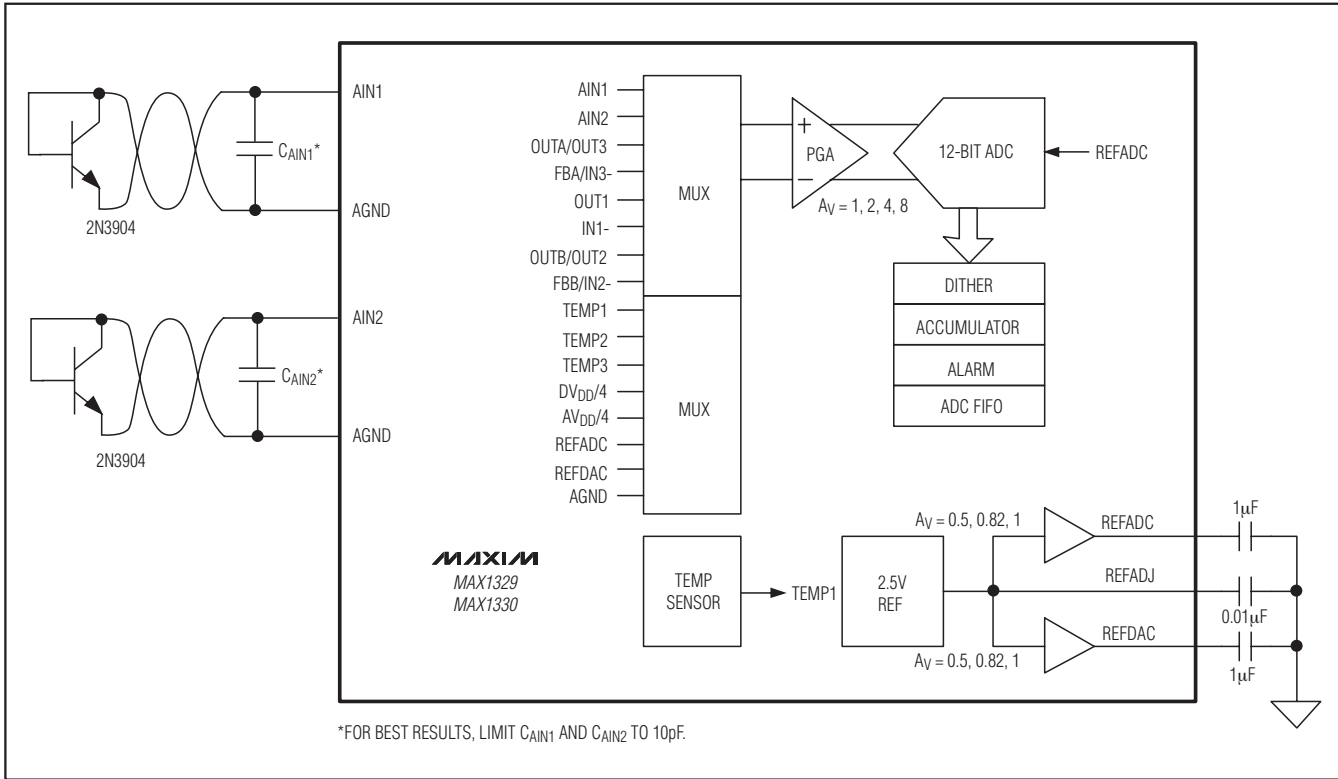

Figure 31. Temperature Measurement with Two Remote Sensors

Programmable-Gain Instrumentation Amplifier

Two op amps and two SPDT switches are configured as a programmable-gain instrumentation amplifier in Figure 32. It includes a differential input and a single-ended output. SPDT1 and SPDT2 are configured as single-pole, double-throw switches. The gain is set by the following equations:

$$V_{OUT} = \left(\frac{R_2 + R_3}{R_1} + 1 \right) (V_{IN+} - V_{IN-})$$

for switch position 1, and

$$V_{OUT} = \left(\frac{R_3}{R_1 + R_2} + 1 \right) (V_{IN+} - V_{IN-})$$

for switch position 2.

12-/16-Bit DASs with ADC, DACs, DPIOs, APIOs, Reference, Voltage Monitors, and Temp Sensor

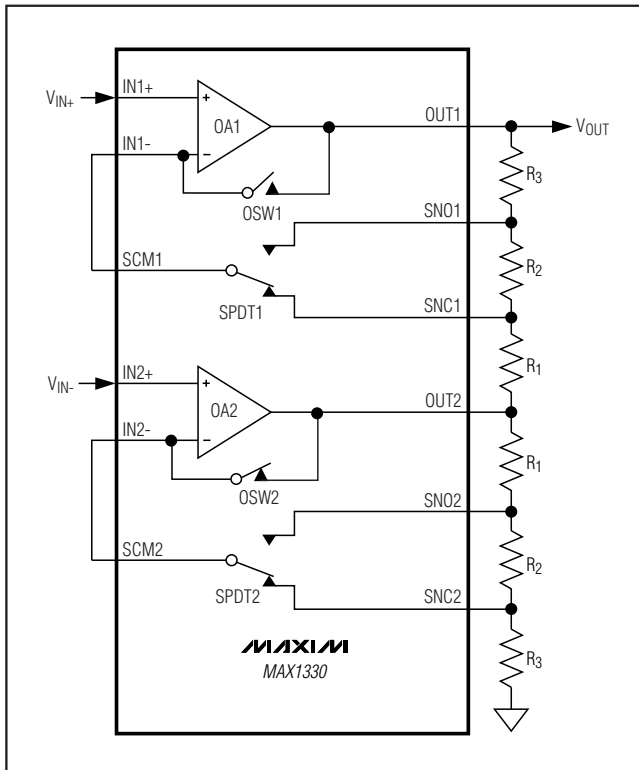

Figure 32. Programmable-Gain Instrumentation Amplifier, Switch Position 1

Synthesizing a Sine Wave

The MAX1329/MAX1330 can easily create up to a 64-point single or periodic sine wave using the DACA and FIFOA. The 16-word FIFO or memory is used to create the first quarter of the waveform and symmetry is used to extend the waveform to produce a complete period. See the *DAC FIFO and Direct Digital Synthesis (DDS) Logic* section for detailed waveform generation. The first data point is the DACA input register data. The FIFOA data is offset from this initial data. To determine the values to be written to the FIFOA Data register use the following equation.

$$\text{FIFOA_DATA}(n) = A \times \sin((n/N) \times 90^\circ)$$

where

$n = 1$ to N ,

$N = \text{DPTA}\langle 3:0 \rangle$,

$A = (V_{\text{PEAK}}/V_{\text{REFDAC}}) \times 4096$,

V_{PEAK} is the desired peak voltage of the sine wave,

and V_{REFDAC} is the DAC reference voltage programmed at REFDAC.

Round the FIFOA_DATA(n) values to the nearest integer and write these values to the FIFOA Data register. Figure 33 shows a sine wave with a 2Vp-p output and with a 1.25V offset. Write the DACA Control register with 0x43 to enable DACA, enable the internal reference, and to set REFDAC to 2.5V. Write to the DACA input and output register by performing a direct mode write with 0x4800 to set DACA to midscale or 1.25V. Write the FIFOA Control register with 0x7F to disable FIFOA and allow a write to the FIFOA Data register, enabling bipolar, symmetry, and continuous modes, and setting the depth to 16.

The FIFOA data calculated from the above equation is 161, 320, 476, 627, 772, 910, 1039, 1159, 1267, 1362, 1445, 1514, 1568, 1607, 1631, and 1638 decimal. Write the FIFOA Data register with 0x0A10 1400 1DC0 2730 3040 38E0 40F0 4870 4F30 5520 5A50 5EA0 6200 6470 65F0 6660 as a contiguous bit stream to fill the FIFOA Data register with data. Write to the FIFOA Control register with 0xFF to enable FIFOA and to disallow writes to the FIFOA Data register. Write to the DPIO Control register with 0x0007 to program DPIO1 as an input to sequence the DACA FIFO on each rising edge. Write to the Switch Control register with 0x80 to close the DACA switch to put the buffer into unity gain. Input a continuous clock to DPIO1 that is 4 x N times (N = 16) the desired frequency of the synthesized waveform. Figure 33 should be observable on OUTA.

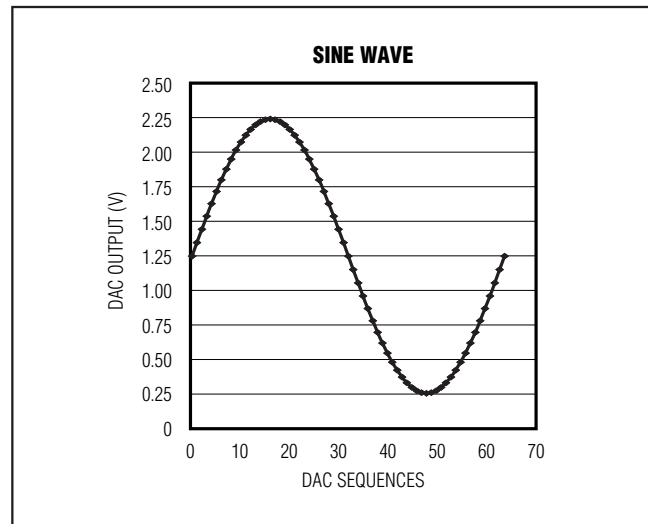

Figure 33. Example Sine-Wave Output

12-/16-Bit DASs with ADC, DACs, DPIOs, APIOs, Reference, Voltage Monitors, and Temp Sensor

Charge-Pump Component Selection

Optimize the charge-pump circuit for size, quiescent current, and output ripple by properly selecting the operating frequency and capacitors C_{DVDD} , C_{FLY} , and C_{AVDD} (Table 32). The charge pump is capable of providing a maximum of 25mA including what is used internally. If less than 25mA is required, smaller capacitor values can be utilized.

For lowest ripple, select 117kHz operation ($CPDIV<1:0> = 00$ and $OSCE = 1$ when using the internal oscillator). In addition, increasing C_{AVDD} relative to C_{FLY} further reduces ripple. For highest efficiency, select 14.6kHz operation ($CPDIV<1:0> = 11$ and $OSCE = 1$ when using the internal oscillator) and select the largest practical values for C_{AVDD} and C_{FLY} while maintaining at least a 30-to-1 ratio. For smallest size, select 117kHz operation. See Table 32 for some suggested values and resulting ripple for 25mA load current. See Figure 34 for load current vs. flying capacitor value when optimizing for other load currents.

Note that the capacitors must have low ESR to maintain low ripple. The C_{FLY} flying capacitor ESR needs to be $< 0.1\Omega$; and the C_{AVDD} and C_{DVDD} filter capacitor ESR needs to be $< 0.3\Omega$. The C_{FLY} flying capacitor can easily be a ceramic capacitor; and the C_{AVDD} and C_{DVDD} filter capacitor can be a low-ESR tantalum or may need to be a combination of a small ceramic and a larger tantalum capacitor.

When $DVDD$ is lower than $AVDD$, the charge pump always operates in voltage-doubler mode. It regulates the output voltage using a pulse-width-modulation (PWM) scheme. Using a PWM scheme ensures that the charge pump is synchronous with the internal ADC preventing corruption of the conversion results.

Table 32. External Component Selection for 25mA Output Current and $2V_{DVDD} - V_{AVDD} \geq 0.4V$ (Figure 25)

CHARGE-PUMP CLOCK (kHz)	$I_{LOAD, MAX}$ (mA)	C_{FLY} (μF)	C_{AVDD} (μF)	C_{DVDD} (μF)	RIPPLE (mV)
14.4	25	1.7	55.6	17.4	32
	12.5	0.9	27.8	8.7	
28.8	25	0.9	27.8	8.7	32
	12.5	0.4	13.9	4.3	
57.6	25	0.4	13.9	4.3	32
	12.5	0.2	6.9	2.2	
115.2	25	0.2	6.9	2.2	32
	12.5	0.1	3.5	1.1	

Operating the Analog Switches

The MAX1329/MAX1330 include two single-pole double-throw (SPDT) and three single-pole single-throw (SPST) analog switches. The two SPDT analog switches are uncommitted and the three SPST analog switches are connected between the DAC buffer or op amp outputs and the inverting inputs.

The analog switches can be controlled using the Switch Control register or any of the DPIOs. See the DPIO Control and DPIO Setup registers to program the DPIOs. The DPIOs should be used when direct control is critical such as synchronizing with another event or if the SPI bus bandwidth is not sufficient for the intended application. The register bit for the analog switch is logically OR'd with DPIOs enabled to control that switch.

The SPDT1 and SPDT2 analog switches can be operated as a SPDT or as a double-pole single-throw (DPST). In the DPST mode, both switches can be opened or closed together. This is useful when connecting two external nodes to a common point. If a lower on-resistance is required, NO_* and NC_* can be connected together externally and be used as a SPST analog switch with half the on-resistance.

The SPST analog switches are intended to be used to set the DAC buffers and op amps to unity gain internally by software control. When the DAC buffers and op amps are used as transimpedance amplifiers, the SPST analog switches can be used to short the external transimpedance resistor during high current periods to keep the amplifier output in compliance.

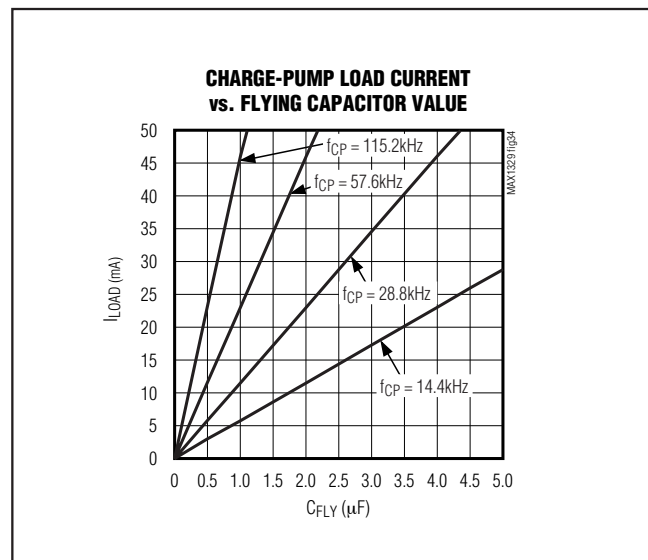

Figure 34. Load Current vs. C_{FLY} Value for $2V_{DVDD} - V_{AVDD} \geq 0.4V$

12-/16-Bit DASs with ADC, DACs, DPIOs, APIOs, Reference, Voltage Monitors, and Temp Sensor

Using the Internal Reference and Reference Buffers

The MAX1329/MAX1330 include a precision 2.5V internal reference and two independent programmable buffers for the ADC and DACs. See the ADC Control and DAC Control registers to enable the internal reference and program the buffers. The REFADJ output is fixed at 2.5V (REFE = 1) and the REFADC and REFDAC connect to the internal ADC reference input and the internal DAC reference inputs, respectively. These buffers can be programmed to output 1.25V, 2.048V, or 2.5V independent of each other. This allows the dynamic range of the ADC and DACs to be optimized or set differently. This is useful if one of the reference voltages is needed to be approximately $V_{DD}/2$ to be used as an analog ground.

The flexibility of the reference circuit allows the internal reference to be shutdown (REFE = 0) and an external voltage reference applied to REFADJ. If either REFADC or REFDAC requires a different or more accurate voltage, an external reference can be applied directly to REFADC or REFDAC and the corresponding reference buffer must be disabled.

Applying a Digital Filter to ADC Data Using the 20-Bit Accumulator

The MAX1329/MAX1330 incorporate a 20-bit accumulator that can sum up to 256 results of the 12-bit ADC automatically. See the *ADC Accumulator Register* section to set the number of samples to be summed. Once the accumulator is full, the ACF bit in the Status register is asserted.

The accumulator provides a digital filtering sync function, with an effective data rate equal to $f_{EDR} = f_s/n$ where f_s is the ADC sample rate and n is the number of samples accumulated. There is a notch at every integer multiple of f_{EDR} . The following equation provides the transfer function of the filter:

$$H(f) = \frac{\sin\left(\frac{n\pi f}{f_s}\right)}{\left(\frac{n\pi f}{f_s}\right)} = \text{sinc}\left(\frac{n\pi f}{f_s}\right)$$

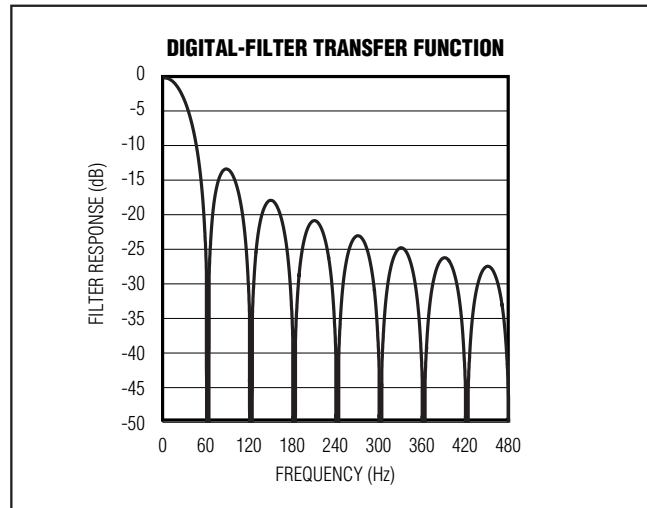

Figure 35. Plot of the Digital Filter with 60Hz Notch

Figure 35 is a plot showing a notch at 60Hz by accumulating 256 samples at 15.36ksps.

The final step is to read the data in the ADC Accumulator register and divide by the number of samples that were accumulated. Shift the data right for each binary multiple of accumulated data. For example, for 256 samples the data should be shifted right eight times.

Increasing ADC Resolution using the Accumulator with Dither

The MAX1329/MAX1330 incorporate an internal dither function that can be used along with the 20-bit accumulator to easily increase the resolution of the 12-bit ADC to up to 16 bits. The oversampling along with the dither increases the resolution with the penalty of a lower effective data rate. Use the following equation to determine the number of samples required to increase the resolution by N number of bits:

$$\text{Samples} = 2^{2N}$$

To increase the resolution by 4 bits, from 12 to 16 bits, 256 samples are required. After accumulating the required number of samples, read the data from the ADC Accumulator register and shift right by 4 bits with the 16 LSBs as the increased resolution result.

12-/16-Bit DASs with ADC, DACs, DPIOs, APIOs, Reference, Voltage Monitors, and Temp Sensor

Using the ADC with the ADC LT (Less-Than) and GT (Greater-Than) Digital Alarms

The ADC LT and GT alarms compare the latest ADC result to the values programmed in the ADC LT Alarm and ADC GT Alarm registers, if enabled, and assert the appropriate GTA or LTA status bit in the Status register once the threshold has been exceeded. The digital alarms can be used as a safeguard during normal ADC conversions to signify an event. Change the GT and LT alarm thresholds, if needed, when selecting a new mux input channel. The ADC can be put into autoconversion mode to continuously convert without user intervention. See the AUTO<2:0> bits in the *ADC Control Register* section to enable the auto mode and to program the ADC conversion rate.

Layout, Grounding, and Bypassing

For best performance, use PCBs. Do not use wire-wrap boards. Board layout should ensure that digital and analog signal lines are separated from each other. Do not run analog and digital (especially clock) signals parallel to one another or run digital lines underneath the MAX1329/MAX1330 package. High-frequency noise in the V_{DD} power supply can affect the MAX1329/MAX1330 performance. Bypass the AV_{DD} and DV_{DD} supplies with a 0.1μF capacitor to GND, close to the AV_{DD} and DV_{DD} pins (see Table 32 for recommended capacitor values). Minimize capacitor lead lengths for best supply-noise rejection.

Selector Guide

PART	NO. OF DACS	NO. OF OP AMPS	TEMP SENSOR ACCURACY (°C)	INTERNAL REFERENCE TEMP COEFFICIENT (ppm/°C max)	TEMP RANGE
MAX1329BETL+	2	1	±3	±75	-40°C to +85°C
MAX1330BETL+	1	2	±3	±75	-40°C to +85°C

+Denotes a lead-free/RoHS-compliant package.

12-/16-Bit DASs with ADC, DACs, DPIOs, APIOs, Reference, Voltage Monitors, and Temp Sensor

Functional Diagrams

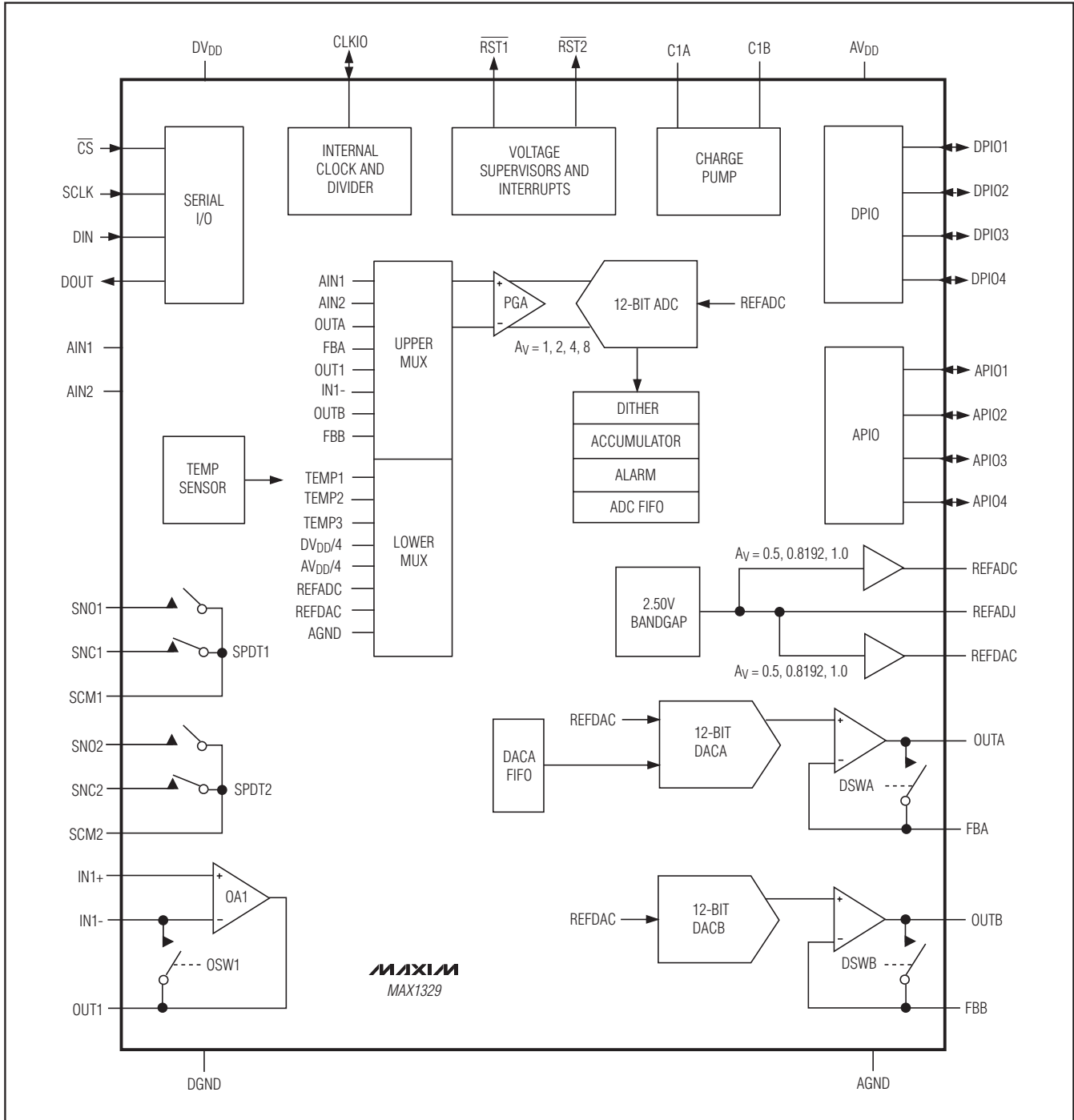

12-/16-Bit DASs with ADC, DACs, DPIOs, APIOs, Reference, Voltage Monitors, and Temp Sensor

Functional Diagrams (continued)

MAX1329/MAX1330

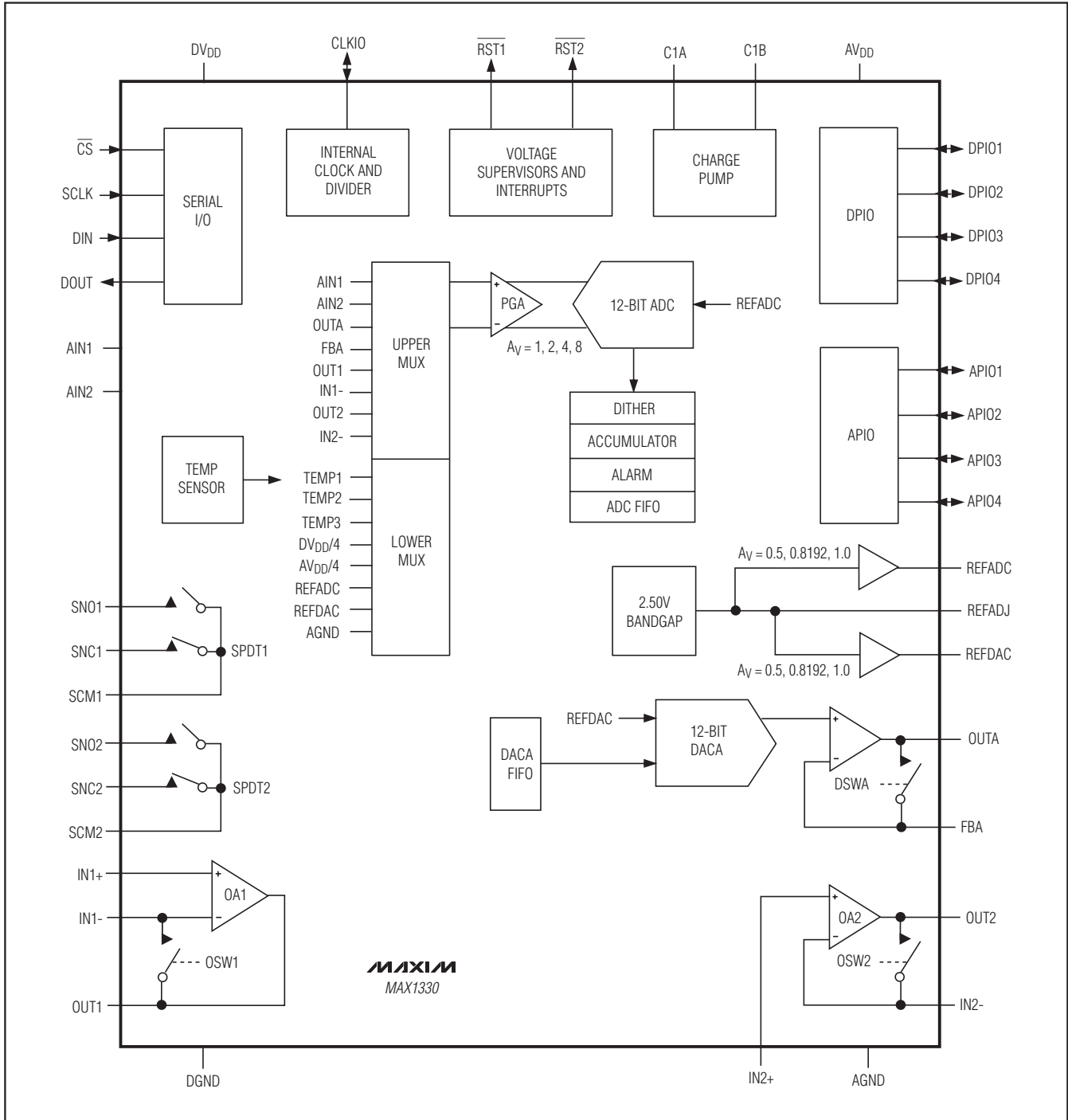

12-/16-Bit DASs with ADC, DACs, DPIOs, APIOs, Reference, Voltage Monitors, and Temp Sensor

Typical Operating Circuit

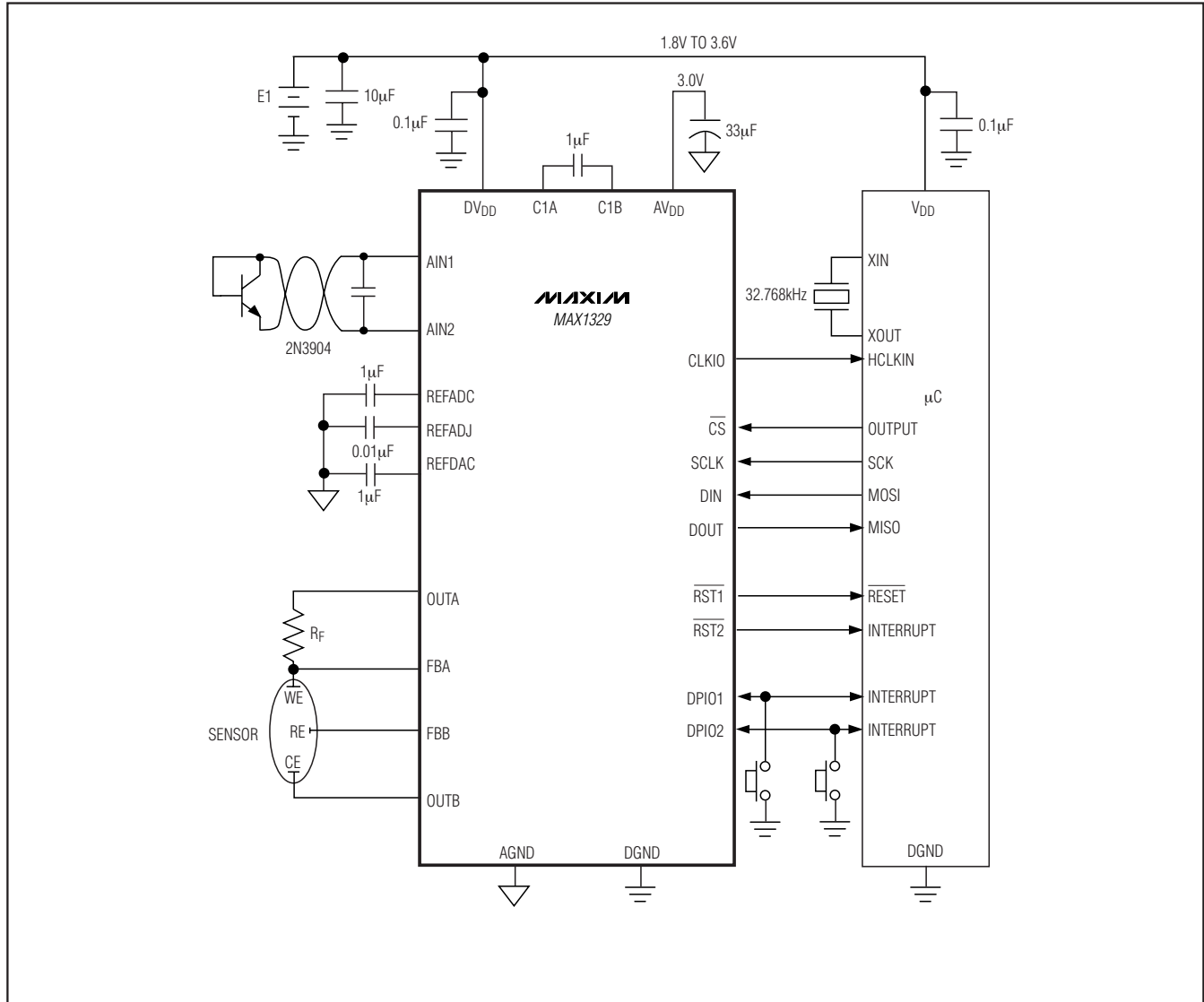

12-/16-Bit DASs with ADC, DACs, DPIOs, APIOs, Reference, Voltage Monitors, and Temp Sensor

Pin Configurations

MAX1329/MAX1330

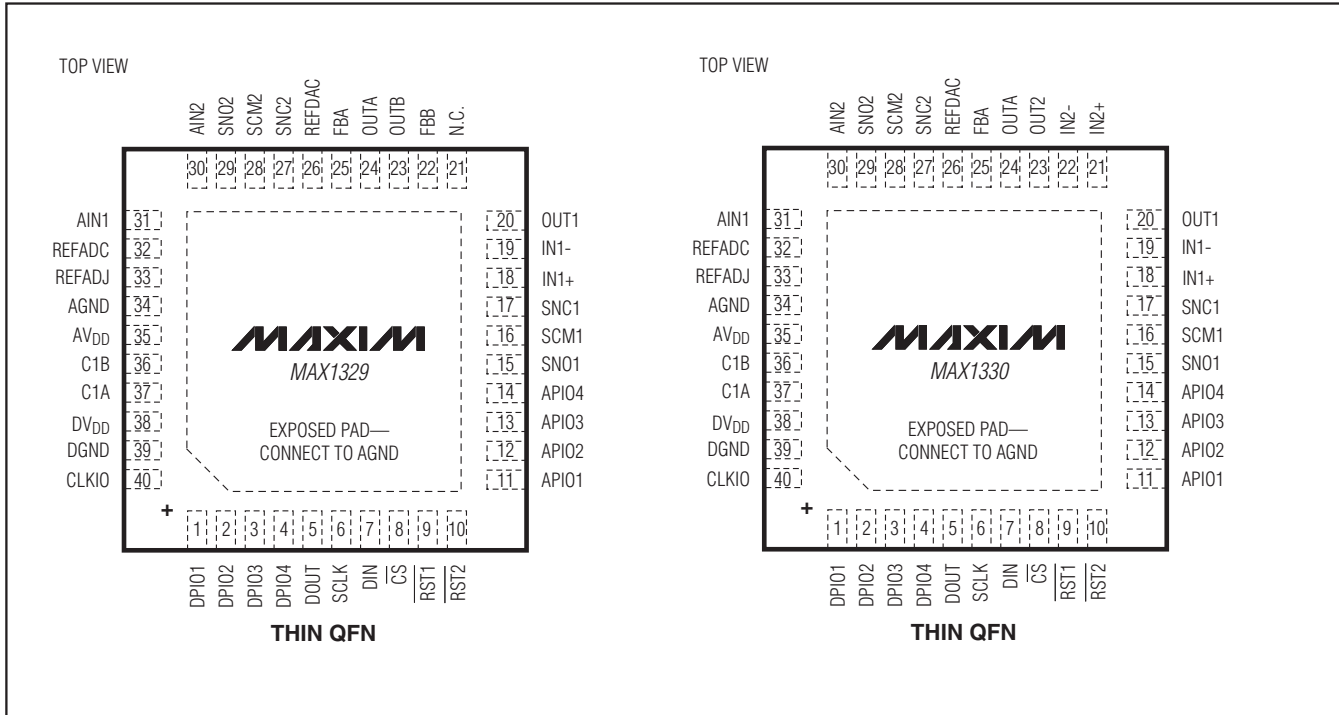

Package Information

For the latest package outline information and land patterns, go to www.maxim-ic.com/packages.

PACKAGE TYPE	PACKAGE CODE	DOCUMENT NO.
40 TQFN-EP	T4066-5	21-0141

12-/16-Bit DASs with ADC, DACs, DPIOs, APIOs, Reference, Voltage Monitors, and Temp Sensor

Revision History

REVISION NUMBER	REVISION DATE	DESCRIPTION	PAGES CHANGED
0	8/08	Initial release	—
1	10/08	Corrected Absolute Maximum Ratings table	2

Maxim cannot assume responsibility for use of any circuitry other than circuitry entirely embodied in a Maxim product. No circuit patent licenses are implied. Maxim reserves the right to change the circuitry and specifications without notice at any time.

78 _____ **Maxim Integrated Products, 120 San Gabriel Drive, Sunnyvale, CA 94086 408-737-7600**

Данный компонент на территории Российской Федерации

Вы можете приобрести в компании MosChip.

Для оперативного оформления запроса Вам необходимо перейти по данной ссылке:

<http://moschip.ru/get-element>

Вы можете разместить у нас заказ для любого Вашего проекта, будь то серийное производство или разработка единичного прибора.

В нашем ассортименте представлены ведущие мировые производители активных и пассивных электронных компонентов.

Нашей специализацией является поставка электронной компонентной базы двойного назначения, продукции таких производителей как XILINX, Intel (ex.ALTERA), Vicor, Microchip, Texas Instruments, Analog Devices, Mini-Circuits, Amphenol, Glenair.

Сотрудничество с глобальными дистрибьюторами электронных компонентов, предоставляет возможность заказывать и получать с международных складов практически любой перечень компонентов в оптимальные для Вас сроки.

На всех этапах разработки и производства наши партнеры могут получить квалифицированную поддержку опытных инженеров.

Система менеджмента качества компании отвечает требованиям в соответствии с ГОСТ Р ИСО 9001, ГОСТ РВ 0015-002 и ЭС РД 009

Офис по работе с юридическими лицами:

105318, г.Москва, ул.Щербаковская д.3, офис 1107, 1118, ДЦ «Щербаковский»

Телефон: +7 495 668-12-70 (многоканальный)

Факс: +7 495 668-12-70 (доб.304)

E-mail: info@moschip.ru

Skype отдела продаж:

moschip.ru

moschip.ru_4

moschip.ru_6

moschip.ru_9