

**SF1131B**

**266 MHz  
SAW Filter**

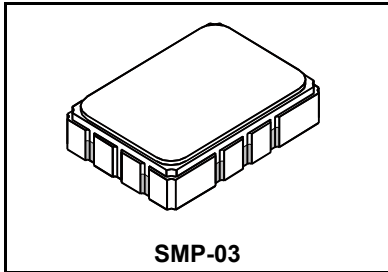

- *Designed for GPS Applications*
- *Quartz Temperature Stability*
- *Small Size*
- *Hermetic 7 x 5 mm Surface-mount Case*
- *Complies with Directive 2002/95/EC (RoHS)*



**Absolute Maximum Ratings**

Rating	Value	Units
Maximum Incident Power in Passband	+10	dBm
Max. DC voltage between any 2 terminals	30	VDC
Storage Temperature Range	-40 to +85	°C
Suitable for lead-free soldering - Max. Soldering Profile	260°C for 30 s	

**Electrical Characteristics**

Characteristic	Sym	Notes	Min	Typ	Max	Units
Nominal Center Frequency	$f_C$	1	266.01			MHz
Passband	Insertion Loss at $f_C$	IL			12.0	dB
	1 db Passband	$BW_1$	0.5			MHz
	3 db Passband	$BW_3$	2.2		2.6	
	Amplitude Ripple over $f_C \pm 0.5$ MHz		1, 2			1.0
Group Delay Variation over $f_C \pm 1.1$ MHz	GDV				250	ns <sub>P-P</sub>
Rejection	$f_C \pm 10$ MHz	1, 2, 3	50			dB
Operating Temperature Range	$T_A$	1	-30		+85	°C

Impedance Matching to 50Ω	External L-C match required to 50 ohms	
Case Style	6	SMP-03 7 x 5 mm Nominal Footprint
Lid Symbolization (YY = year, WW = week)		RFM SF1131B YYWW

 **CAUTION: Electrostatic Sensitive Device. Observe precautions for handling.**

**NOTES:**

1. Unless noted otherwise, all specifications apply over the operating temperature range with filter soldered to the specified demonstration board with impedance matching to 50 Ω and measured with 50 Ω network analyzer.
2. Unless noted otherwise, all frequency specifications are referenced to the nominal center frequency,  $f_C$ .
3. Rejection is measured as attenuation below the minimum IL point in the passband. Rejection in final user application is dependent on PCB layout and external impedance matching design. See Application Note No. 42 for details.
4. "LRIP" or "L" after the part number indicates "low rate initial production" and "ENG" or "E" indicates "engineering prototypes."
5. The design, manufacturing process, and specifications of this filter are subject to change.
6. Tape and Reel Standard ANSI / EIA 481.
7. Either Port 1 or Port 2 may be used for either input or output in the design. However, impedances and impedance matching may vary between Port 1 and Port 2, so that the filter must always be installed in one direction per the circuit design.
8. US and international patents may apply.

**Electrical Connections**

Connection	Terminals
Port 1	1, 10
Port 2	5, 6
Case Ground	All others

## Tape and Reel Specifications

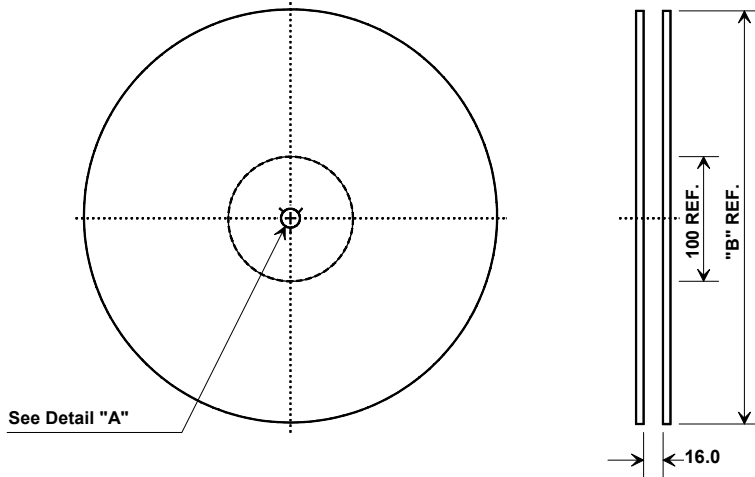

"B " Nominal Size		Quantity Per Reel
Inches	millimeters	
7	178	500
13	330	2000

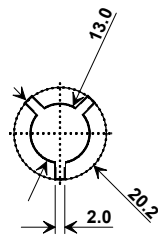

### COMPONENT ORIENTATION and DIMENSIONS

Carrier Tape Dimensions	
<b>Ao</b>	5.5 mm
<b>Bo</b>	7.5 mm
<b>Ko</b>	2.0 mm
<b>Pitch</b>	8.0 mm
<b>W</b>	16.0 mm

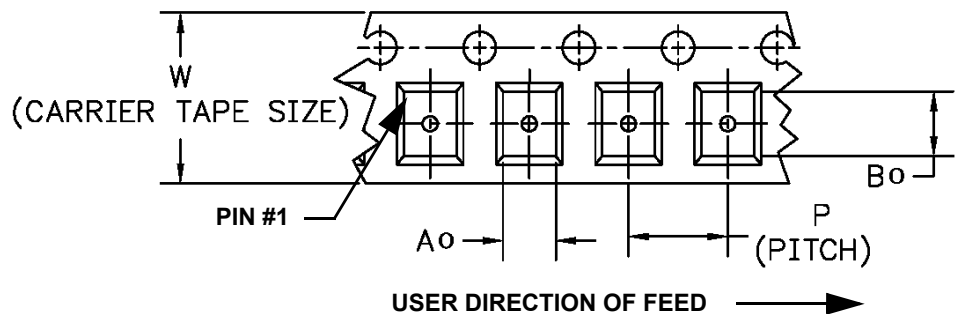
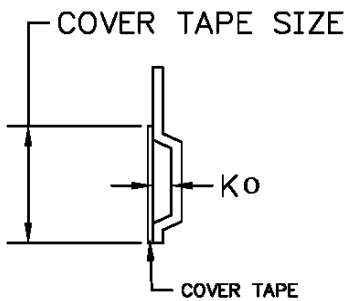

# SMP-03 Case

## 10-Terminal Ceramic Surface-Mount Case 7 x 5 mm Nominal Footprint

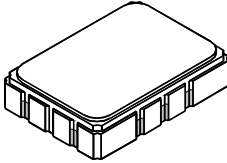

### Recommended PCB Footprint

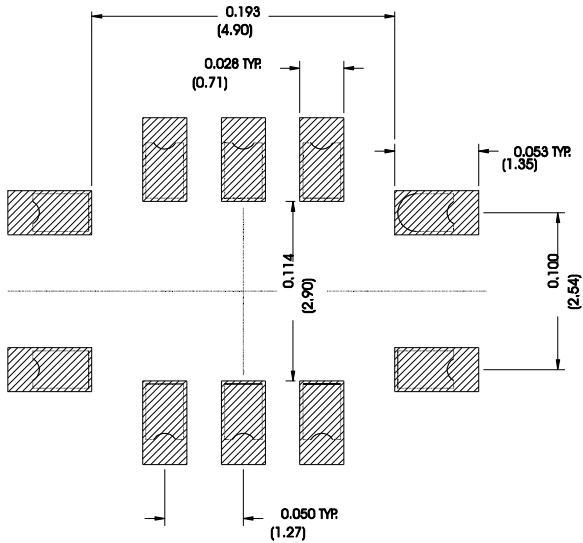

Case Dimensions						
Dimension	mm			Inches		
	Min	Nom	Max	Min	Nom	Max
A	6.80	7.00	7.20	0.268	0.276	0.283
B	4.80	5.00	5.20	0.189	0.197	0.205
C		1.65	2.00		0.065	0.079
D		0.60			0.024	
E		2.54			0.100	
H		1.0			0.039	
J		5.00			0.197	
K		3.00			0.118	
P		1.27			0.050	

Electrical Connections		
Connection		Terminals
Port 1	Input or Return	10
	Return or Input	1
Port 2	Output or Return	5
	Return or Output	6
Ground		All others
<b>Single Ended Operation</b>		<b>Return is ground</b>
<b>Differential Operation</b>		<b>Return is hot</b>

Materials	
Solder Pad Termination	Au plating 30 - 60 unches (76.2-152 uM) over 80-200 unches (203-508 uM) Ni.
Lid	Fe-Ni-Co Alloy Electroless Nickel Plate (8-11% Phosphorus) 100-200 unches Thick
Body	Al <sub>2</sub> O <sub>3</sub> Ceramic
Pb Free	

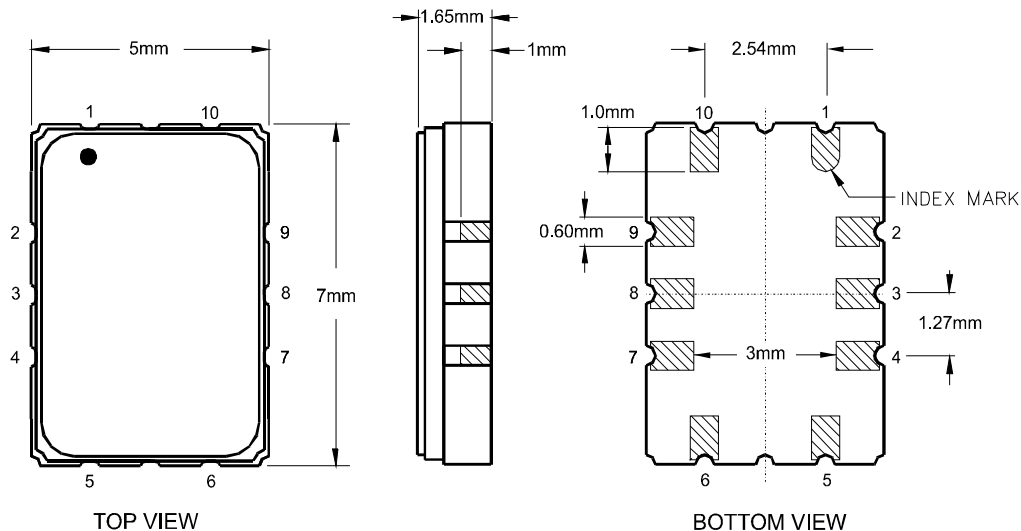

## Данный компонент на территории Российской Федерации

### Вы можете приобрести в компании MosChip.

Для оперативного оформления запроса Вам необходимо перейти по данной ссылке:

<http://moschip.ru/get-element>

Вы можете разместить у нас заказ для любого Вашего проекта, будь то серийное производство или разработка единичного прибора.

В нашем ассортименте представлены ведущие мировые производители активных и пассивных электронных компонентов.

Нашей специализацией является поставка электронной компонентной базы двойного назначения, продукции таких производителей как XILINX, Intel (ex.ALTERA), Vicor, Microchip, Texas Instruments, Analog Devices, Mini-Circuits, Amphenol, Glenair.

Сотрудничество с глобальными дистрибьюторами электронных компонентов, предоставляет возможность заказывать и получать с международных складов практически любой перечень компонентов в оптимальные для Вас сроки.

На всех этапах разработки и производства наши партнеры могут получить квалифицированную поддержку опытных инженеров.

Система менеджмента качества компании отвечает требованиям в соответствии с ГОСТ Р ИСО 9001, ГОСТ РВ 0015-002 и ЭС РД 009

### Офис по работе с юридическими лицами:

105318, г.Москва, ул.Щербаковская д.3, офис 1107, 1118, ДЦ «Щербаковский»

Телефон: +7 495 668-12-70 (многоканальный)

Факс: +7 495 668-12-70 (доб.304)

E-mail: [info@moschip.ru](mailto:info@moschip.ru)

Skype отдела продаж:

moschip.ru

moschip.ru\_4

moschip.ru\_6

moschip.ru\_9