



## Features

- Tip & ring line protection with two devices in one surface mount package
- High voltage surge capabilities
- Assists in meeting ITU-T K.20/K.21/K.45 specifications as well as Telcordia GR-1089 intra-building
- RoHS compliant\*
- Agency recognition:

## Applications

Used as a secondary overcurrent protection device in:

- Customer Premise Equipment (CPE)
- Central Office (CO)
- Subscriber Line Interface Cards (SLIC)

## MF-SD/250 Series - Telecom PTC Resettable Fuses

### Electrical Characteristics

Model	Max. Operating Voltage Volts	Max. Interrupt Ratings		Ihold	Itrip	Initial Resistance		1 Hour (R <sub>1</sub> ) Post-Trip Resistance*	Nominal Time to Trip		Tripped Power Dissipation Watts at 23 °C
		Volts (V)	Amps (A)			Amperes at 23 °C			Ohms at 23 °C		
				Hold	Trip	Min.	Max.	Max.	Typ.		
MF-SD013/250	60	250	3.0	0.13	0.26	2.0	7.0	10.0	1	2.5	1.5

\* R<sub>1</sub> value is measured 24 hours post reflow.  
Resistance matched in housing: 1.0 ohm measured 24 hours after reflow installation.

### Environmental Characteristics

Operating Temperature.....	-45 °C to +85 °C
Maximum Device Surface Temperature in Tripped State.....	125 °C
Passive Aging.....	+85 °C, 1000 hours.....±15 % typical resistance change
.....	+60 °C, 1000 hours.....±15 % typical resistance change
Humidity Aging.....	+85 °C, 85 % R.H. 1000 hours.....±15 % typical resistance change
Thermal Shock.....	MIL-STD-202F, Method 107G.....±10 % typical resistance change
.....	+125 °C to -55 °C, 10 times.....±15 % typical resistance change
Solvent Resistance.....	MIL-STD-202, Method 215B.....No change
Lead Solderability.....	ANSI/J-STD-002
Flammability.....	IEC 695-2-2.....No Flame for 60 secs.
Vibration.....	MIL-STD-883C, Method 2007.1, Condition A.....No change

### Test Procedures And Requirements For Model MF-SD/250 Series

Test	Test Conditions	Accept/Reject Criteria
Visual/Mech.....	Verify dimensions and materials.....	Per MF physical description
Resistance.....	In still air @ 23 °C.....	R <sub>min</sub> ≤ R ≤ R <sub>max</sub>
Time to Trip.....	At specified current, V <sub>max</sub> , 23 °C.....	T ≤ max. time to trip (seconds)
Hold Current.....	30 min. at Ihold.....	No trip

Test	Test Conditions	Primary Protection
Mains Power Contact - ITU-T K.20, K.21.....	230 V rms, 10 ohms, t = 15 min.....	None
Power Induction - ITU-T K.20, K.21.....	600V rms, 600 ohms, t = 0.2 seconds.....	None
Power Induction - ITU-T K.20, K.21.....	600 V rms, 600 ohms, t = 1 second.....	GDT
Lightning Surge - ITU-T K.20, K.21.....	1.5 KV, 10/700 μs.....	None
Lightning Surge.....	4.0 KV, 10/700 μs.....	GDT

UL File Number..... E 174545S

### Thermal Derating Chart -Ihold (Amps)

Model	Ambient Operating Temperature								
	-40 °C	-20 °C	0 °C	23 °C	40 °C	50 °C	60 °C	70 °C	85 °C
MF-SD013/250	0.21	0.18	0.16	0.13	0.10	0.09	0.08	0.07	0.05

\*RoHS Directive 2002/95/EC Jan. 27, 2003 including annex and RoHS Recast 2011/65/EU June 8, 2011.  
Specifications are subject to change without notice.  
Customers should verify actual device performance in their specific applications.

# MF-SD/250 Series - Telecom PTC Resettable Fuses



## Product Dimensions

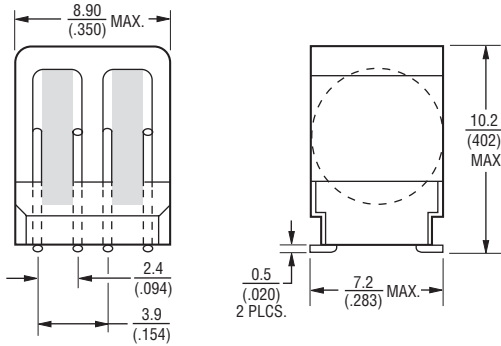

DIMENSIONS:  $\frac{\text{MM}}{\text{(INCHES)}}$

Packaging: TAPE & REEL = 400 pcs. per reel

## Recommended Pad Layout

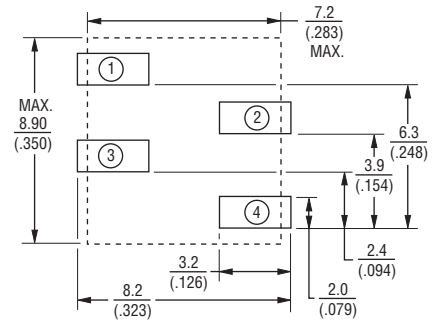

## Typical Time to Trip at 23 °C

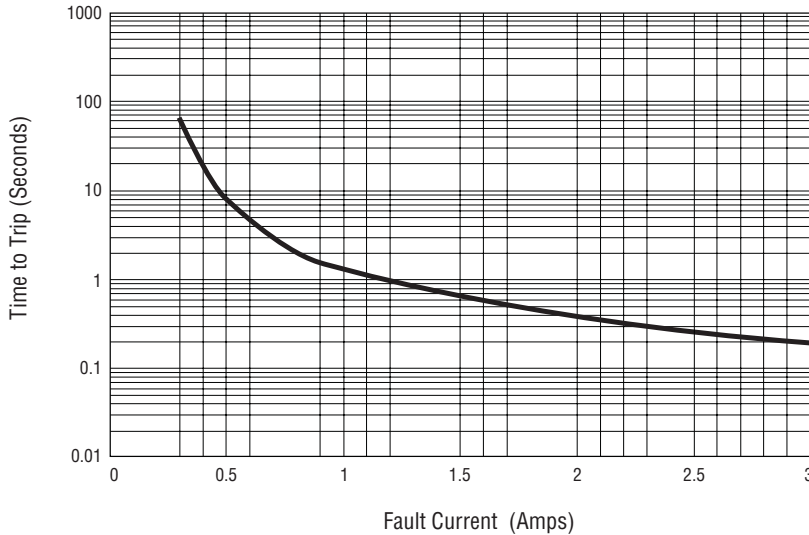

## Schematic

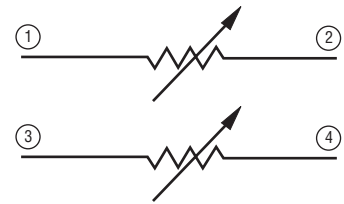

## Typical Part Marking

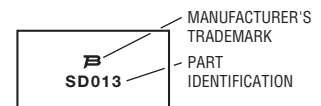

## How to Order

**MF - SD 013/250 - 2**

Multifuse® Product Designator \_\_\_\_\_

Series \_\_\_\_\_  
 SD = Surface Mount Dual Package

Hold Current, I<sub>hold</sub> \_\_\_\_\_  
 013 (0.13 Amps)

Max. Interrupt Voltage, V \_\_\_\_\_  
 250 = 250 Volts

Packaging \_\_\_\_\_  
 - 2 = Tape and Reel\*

\*Packaged per EIA481-2

## Solder Reflow Recommendations

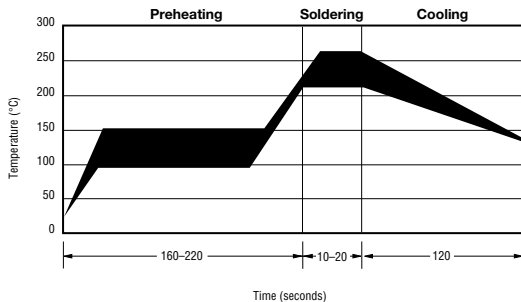

### Solder reflow:

- Recommended reflow methods: IR, vapor phase oven, hot air oven.
- Devices are not designed to be wave soldered to the bottom side of the board.
- Gluing the devices is not recommended.
- Recommended maximum paste thickness is 0.25 mm (.010 inch).
- Devices can be cleaned using standard industry methods and solvents.

### Note:

- If reflow temperatures exceed the recommended profile, devices may not meet the performance requirements.

### Rework:

- A device should not be reworked.

Specifications are subject to change without notice.  
 Customers should verify actual device performance in their specific applications.

# MF-SD/250 Series - Telecom PTC Resettable Fuses

**BOURNS®**

## Storage Recommendations

The recommended long term storage conditions for Multifuse® Polymer PTC devices are 40 °C maximum and 70 % RH maximum. All devices should remain in the original sealed packaging prior to use. Devices may not conform with data sheet specifications if these storage recommendations are exceeded. Devices stored in this manner have an indefinite shelf life.

## Packaging Dimensions

Tape Dimensions	MF-SD/250 Series per EIA 481-2
W	$24.0 \pm 0.5$ (0.945 ± 0.020)
P <sub>0</sub>	$4.0$ (0.157)
P	$16.0$ (0.630)
P <sub>2</sub>	$2.0$ (0.079)
A <sub>0</sub>	$7.5 \pm 0.2$ (0.295 ± 0.008)
B <sub>0</sub>	$9.0 \pm 0.2$ (0.354 ± 0.008)
D	$1.5$ (0.059)
F	$11.5$ (0.453)
E	$1.75$ (0.069)
t	$0.5 \pm 0.15$ (0.020 ± 0.006)
K <sub>0</sub>	$10.0 \pm 0.2$ (0.394 ± 0.008)
Leader min.	$390$ (15.35)
Trailer min.	$160$ (6.30)

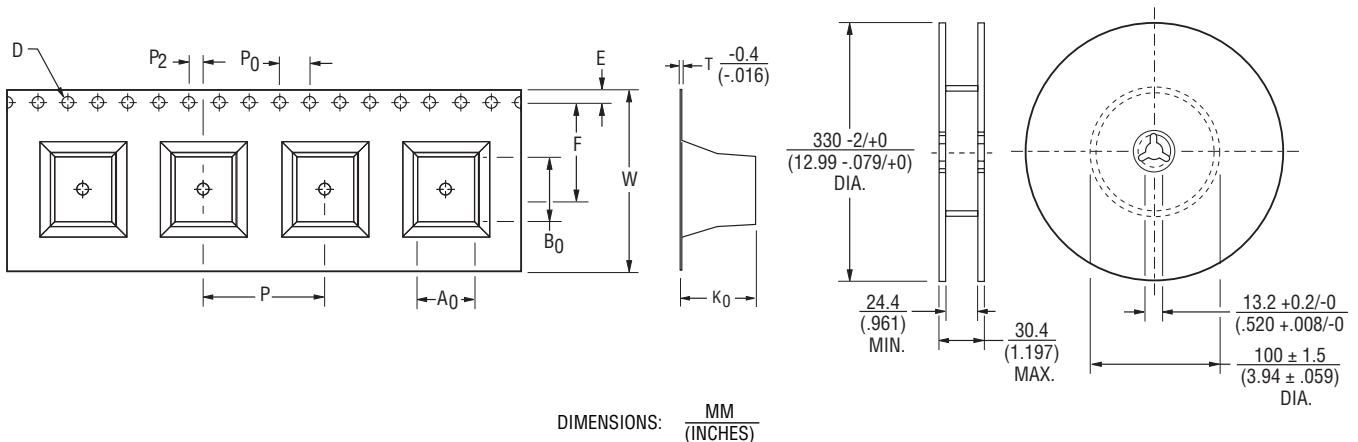

MF-SD/250, REV. D 08/12

Specifications are subject to change without notice.  
Customers should verify actual device performance in their specific applications.

## Данный компонент на территории Российской Федерации

### Вы можете приобрести в компании MosChip.

Для оперативного оформления запроса Вам необходимо перейти по данной ссылке:

<http://moschip.ru/get-element>

Вы можете разместить у нас заказ для любого Вашего проекта, будь то серийное производство или разработка единичного прибора.

В нашем ассортименте представлены ведущие мировые производители активных и пассивных электронных компонентов.

Нашей специализацией является поставка электронной компонентной базы двойного назначения, продукции таких производителей как XILINX, Intel (ex.ALTERA), Vicor, Microchip, Texas Instruments, Analog Devices, Mini-Circuits, Amphenol, Glenair.

Сотрудничество с глобальными дистрибьюторами электронных компонентов, предоставляет возможность заказывать и получать с международных складов практически любой перечень компонентов в оптимальные для Вас сроки.

На всех этапах разработки и производства наши партнеры могут получить квалифицированную поддержку опытных инженеров.

Система менеджмента качества компании отвечает требованиям в соответствии с ГОСТ Р ИСО 9001, ГОСТ РВ 0015-002 и ЭС РД 009

### Офис по работе с юридическими лицами:

105318, г.Москва, ул.Щербаковская д.3, офис 1107, 1118, ДЦ «Щербаковский»

Телефон: +7 495 668-12-70 (многоканальный)

Факс: +7 495 668-12-70 (доб.304)

E-mail: [info@moschip.ru](mailto:info@moschip.ru)

Skype отдела продаж:

moschip.ru

moschip.ru\_4

moschip.ru\_6

moschip.ru\_9