



**MICROCHIP**

---

**MCP6N16  
Evaluation Board  
User's Guide**

---

---

**Note the following details of the code protection feature on Microchip devices:**

- Microchip products meet the specification contained in their particular Microchip Data Sheet.
- Microchip believes that its family of products is one of the most secure families of its kind on the market today, when used in the intended manner and under normal conditions.
- There are dishonest and possibly illegal methods used to breach the code protection feature. All of these methods, to our knowledge, require using the Microchip products in a manner outside the operating specifications contained in Microchip's Data Sheets. Most likely, the person doing so is engaged in theft of intellectual property.
- Microchip is willing to work with the customer who is concerned about the integrity of their code.
- Neither Microchip nor any other semiconductor manufacturer can guarantee the security of their code. Code protection does not mean that we are guaranteeing the product as "unbreakable."

Code protection is constantly evolving. We at Microchip are committed to continuously improving the code protection features of our products. Attempts to break Microchip's code protection feature may be a violation of the Digital Millennium Copyright Act. If such acts allow unauthorized access to your software or other copyrighted work, you may have a right to sue for relief under that Act.

---

Information contained in this publication regarding device applications and the like is provided only for your convenience and may be superseded by updates. It is your responsibility to ensure that your application meets with your specifications. MICROCHIP MAKES NO REPRESENTATIONS OR WARRANTIES OF ANY KIND WHETHER EXPRESS OR IMPLIED, WRITTEN OR ORAL, STATUTORY OR OTHERWISE, RELATED TO THE INFORMATION, INCLUDING BUT NOT LIMITED TO ITS CONDITION, QUALITY, PERFORMANCE, MERCHANTABILITY OR FITNESS FOR PURPOSE. Microchip disclaims all liability arising from this information and its use. Use of Microchip devices in life support and/or safety applications is entirely at the buyer's risk, and the buyer agrees to defend, indemnify and hold harmless Microchip from any and all damages, claims, suits, or expenses resulting from such use. No licenses are conveyed, implicitly or otherwise, under any Microchip intellectual property rights.

**Trademarks**

The Microchip name and logo, the Microchip logo, dsPIC, FlashFlex, flexPWR, JukeBlox, KEELOQ, KEELOQ logo, Kleer, LANCheck, MediaLB, MOST, MOST logo, MPLAB, OptoLyzer, PIC, PICSTART, PIC<sup>32</sup> logo, RightTouch, SpyNIC, SST, SST Logo, SuperFlash and UNI/O are registered trademarks of Microchip Technology Incorporated in the U.S.A. and other countries.

The Embedded Control Solutions Company and mTouch are registered trademarks of Microchip Technology Incorporated in the U.S.A.

Analog-for-the-Digital Age, BodyCom, chipKIT, chipKIT logo, CodeGuard, dsPICDEM, dsPICDEM.net, ECAN, In-Circuit Serial Programming, ICSP, Inter-Chip Connectivity, KleerNet, KleerNet logo, MiWi, MPASM, MPF, MPLAB Certified logo, MPLIB, MPLINK, MultiTRAK, NetDetach, Omniscient Code Generation, PICDEM, PICDEM.net, PICkit, PICtail, RightTouch logo, REAL ICE, SQI, Serial Quad I/O, Total Endurance, TSHARC, USBCheck, VariSense, ViewSpan, WiperLock, Wireless DNA, and ZENA are trademarks of Microchip Technology Incorporated in the U.S.A. and other countries.

SQTP is a service mark of Microchip Technology Incorporated in the U.S.A.

Silicon Storage Technology is a registered trademark of Microchip Technology Inc. in other countries.

GestIC is a registered trademarks of Microchip Technology Germany II GmbH & Co. KG, a subsidiary of Microchip Technology Inc., in other countries.

All other trademarks mentioned herein are property of their respective companies.

© 2015, Microchip Technology Incorporated, Printed in the U.S.A., All Rights Reserved.

ISBN: 978-1-63277-461-3

**QUALITY MANAGEMENT SYSTEM**  
**CERTIFIED BY DNV**  
**== ISO/TS 16949 ==**

*Microchip received ISO/TS-16949:2009 certification for its worldwide headquarters, design and wafer fabrication facilities in Chandler and Tempe, Arizona; Gresham, Oregon and design centers in California and India. The Company's quality system processes and procedures are for its PIC<sup>®</sup> MCUs and dsPIC<sup>®</sup> DSCs, KEELOQ<sup>®</sup> code hopping devices, Serial EEPROMs, microperipherals, nonvolatile memory and analog products. In addition, Microchip's quality system for the design and manufacture of development systems is ISO 9001:2000 certified.*

---

---

**Object of Declaration: MCP6N16 Evaluation Board**

EU Declaration of Conformity

Manufacturer: Microchip Technology Inc.  
2355 W. Chandler Blvd.  
Chandler, Arizona, 85224-6199  
USA

This declaration of conformity is issued by the manufacturer.

The development/evaluation tool is designed to be used for research and development in a laboratory environment. This development/evaluation tool is not a Finished Appliance, nor is it intended for incorporation into Finished Appliances that are made commercially available as single functional units to end users under EU EMC Directive 2004/108/EC and as supported by the European Commission's Guide for the EMC Directive 2004/108/EC (8<sup>th</sup> February 2010).

This development/evaluation tool complies with EU RoHS2 Directive 2011/65/EU.

This development/evaluation tool, when incorporating wireless and radio-telecom functionality, is in compliance with the essential requirement and other relevant provisions of the R&TTE Directive 1999/5/EC and the FCC rules as stated in the declaration of conformity provided in the module datasheet and the module product page available at [www.microchip.com](http://www.microchip.com).

For information regarding the exclusive, limited warranties applicable to Microchip products, please see Microchip's standard terms and conditions of sale, which are printed on our sales documentation and available at [www.microchip.com](http://www.microchip.com).

Signed for and on behalf of Microchip Technology Inc. at Chandler, Arizona, USA

  
Derek Carlson  
VP Development Tools

12-Sep-14  
Date

---

---

**NOTES:**

**Table of Contents**

<b>Preface</b> .....	<b>7</b>
Introduction.....	7
Document Layout .....	7
Conventions Used in this Guide .....	8
Recommended Reading.....	9
The Microchip Web Site .....	9
Customer Support .....	9
Revision History .....	9
<b>Chapter 1. Installation and Operation</b>	
1.1 Introduction .....	11
1.2 Purpose .....	11
1.3 Description .....	11
1.3.1 Block Diagram .....	11
1.3.2 Sensor Connector .....	12
1.3.3 Instrumentation Amplifier .....	12
1.3.4 VREF .....	12
1.3.5 Power Supply Connector .....	12
1.4 What Does This Kit Contain? .....	13
<b>Chapter 2. Installation and Operation</b>	
2.1 Introduction .....	15
2.2 Required Tools .....	15
2.2.1 Bench Setup .....	15
2.3 Basic Configurations .....	16
2.3.1 Out of the Box Setup .....	16
2.3.2 Test Points .....	16
2.3.3 Jumper Settings .....	17
2.4 Detailed Circuit Descriptions .....	18
2.4.1 Power Supply .....	18
2.4.2 Sensor Connection .....	19
2.4.3 Instrumentation Amplifier .....	20
2.4.4 External VREF Circuit .....	24
2.4.5 PIC® Analog/Digital Interface .....	25
<b>Appendix A. Schematic and Layouts</b>	
A.1 Introduction .....	27
A.2 Board – Schematic .....	28
A.3 Board – Top Silk .....	29
A.4 Board – Top Copper and Silk .....	29

# MCP6N16 Evaluation Board User's Guide

---

A.5 Board – Top Copper .....	30
A.6 Board – Bottom Copper .....	30
A.7 Board – Bottom Copper and Silk .....	31
A.8 Board – Bottom Silk .....	31
<b>Appendix B. Bill of Materials (BOM) .....</b>	<b>33</b>
<b>Worldwide Sales and Service .....</b>	<b>36</b>

---

---

## Preface

---

---

### NOTICE TO CUSTOMERS

All documentation becomes dated, and this manual is no exception. Microchip tools and documentation are constantly evolving to meet customer needs, so some actual dialogs and/or tool descriptions may differ from those in this document. Please refer to our web site ([www.microchip.com](http://www.microchip.com)) to obtain the latest documentation available.

Documents are identified with a “DS” number. This number is located on the bottom of each page, in front of the page number. The numbering convention for the DS number is “DSXXXXXXXXA”, where “XXXXXXXX” is the document number and “A” is the revision level of the document.

For the most up-to-date information on development tools, see the MPLAB IDE online help. Select the Help menu, and then Topics to open a list of available online help files.

## INTRODUCTION

This chapter contains general information that will be useful to know before using the MCP6N16 Evaluation Board. Items discussed in this chapter include:

- Document Layout
- Conventions Used in this Guide
- Recommended Reading
- The Microchip Web Site
- Customer Support
- Revision History

## DOCUMENT LAYOUT

This document describes how to use the MCP6N16 Evaluation Board. The document is organized as follows:

- **Chapter 1. “Product Overview”** – Important information about the MCP6N16 Evaluation Board.
- **Chapter 2. “Installation and Operation”** – Covers the initial set-up of this board, required tools, board setup and lab equipment connections.
- **Appendix A. “Schematic and Layouts”** – Shows the schematic and board layouts for the MCP6N16 Evaluation Board.
- **Appendix B. “Bill of Materials (BOM)”** – Lists the parts used to populate the MCP6N16 Evaluation Board. Also lists alternate components.

## CONVENTIONS USED IN THIS GUIDE

This manual uses the following documentation conventions:

### DOCUMENTATION CONVENTIONS

Description	Represents	Examples
<b>Arial font:</b>		
Italic characters	Referenced books	<i>MPLAB IDE User's Guide</i>
	Emphasized text	...is the <i>only</i> compiler...
Initial caps	A window	the Output window
	A dialog	the Settings dialog
	A menu selection	select Enable Programmer
Quotes	A field name in a window or dialog	"Save project before build"
Underlined, italic text with right angle bracket	A menu path	<u><i>File&gt;Save</i></u>
Bold characters	A dialog button	Click <b>OK</b>
	A tab	Click the <b>Power</b> tab
N'Rnnnn	A number in verilog format, where N is the total number of digits, R is the radix and n is a digit.	4'b0010, 2'hF1
Text in angle brackets < >	A key on the keyboard	Press <Enter>, <F1>
<b>Courier New font:</b>		
Plain Courier New	Sample source code	#define START
	Filenames	autoexec.bat
	File paths	c:\mcc18\h
	Keywords	_asm, _endasm, static
	Command-line options	-Opa+, -Opa-
	Bit values	0, 1
	Constants	0xFF, 'A'
Italic Courier New	A variable argument	<i>file.o</i> , where <i>file</i> can be any valid filename
Square brackets [ ]	Optional arguments	mcc18 [options] <i>file</i> [options]
Curly brackets and pipe character: {   }	Choice of mutually exclusive arguments; an OR selection	errorlevel {0 1}
Ellipses...	Replaces repeated text	var_name [, var_name...]
	Represents code supplied by user	void main (void) { ... }



## RECOMMENDED READING

This user's guide describes how to use MCP6N16 Evaluation Board. Other useful documents are listed below. The following Microchip documents are available and recommended as supplemental reference resources.

- **MCP6N16 Data Sheet – “Zero-Drift Instrumentation Amplifier” (DS20005318)**  
Gives detailed information on the instrumentation amplifier.
- **MCP6V11 Data Sheet – “7.5  $\mu$ A, 80 kHz Zero-Drift Op Amps” (DS20005124)**  
Gives detailed information on the op amp as  $V_{REF}$  buffer amplifier.
- **MCP1525 Data Sheet – “2.5V and 4.096V Voltage References” (DS21653)**  
Gives detailed information on the 2.5V voltage reference IC.
- **MCP4018 Data Sheet – “7-Bit Single  $\rho C^{\text{TM}}$  Digital POT with Volatile Memory in SC70” (DS22147)**  
Gives detailed information on the digital potentiometer IC.
- **AN1258 Application Note – “Op Amp Precision Design: PCB Layout Techniques” (DS01258)**  
Discusses methods to minimize thermojunction voltage effects in a PCB design.

## THE MICROCHIP WEB SITE

Microchip provides online support via our web site at [www.microchip.com](http://www.microchip.com). This web site is used as a means to make files and information easily available to customers. Accessible by using your favorite Internet browser, the web site contains the following information:

- **Product Support** – Data sheets and errata, application notes and sample programs, design resources, user's guides and hardware support documents, latest software releases and archived software
- **General Technical Support** – Frequently Asked Questions (FAQs), technical support requests, online discussion groups, Microchip consultant program member listing
- **Business of Microchip** – Product selector and ordering guides, latest Microchip press releases, listing of seminars and events, listings of Microchip sales offices, distributors and factory representatives

## CUSTOMER SUPPORT

Users of Microchip products can receive assistance through several channels:

- Distributor or Representative
- Local Sales Office
- Field Application Engineer (FAE)
- Technical Support

Customers should contact their distributor, representative or field application engineer (FAE) for support. Local sales offices are also available to help customers.

Technical support is available through the web site at:

<http://www.microchip.com/support>.

## REVISION HISTORY

### Revision A (June 2015)

This is the initial release of this document.

NOTES:

## Chapter 1. Product Overview

### 1.1 INTRODUCTION

The MCP6N16 Evaluation Board is described by the following:

- Assembly #: 114-00354-R3
- Order #: ADM00640
- Name: MCP6N16 Evaluation Board

This board uses the following Microchip ICs:

- MCP6N16-100 (Zero-Drift INA)
- MCP6V11 (Zero-Drift, Low-Power Op-Amp)
- MCP1525 (2.5V Voltage Reference)
- MCP4018 (DigiPot Potentiometer, 10 k $\Omega$ )

Items discussed in this chapter include:

- Purpose
- Description
- What Does This Kit Contain?

### 1.2 PURPOSE

This evaluation board is designed to provide an easy and flexible platform when evaluating the performance of Microchip Technology's MCP6N16 Zero-Drift instrumentation amplifier (INA). The fully assembled evaluation board includes differential input filtering, two jumper selectable gain settings and output filtering, in addition to an external voltage reference circuit to allow for an adjustable output common-mode level shifting.

### 1.3 DESCRIPTION

#### 1.3.1 Block Diagram

Figure 1-1 shows the overall functionality of this evaluation board, followed by a brief description of each block. Detailed information is available in [Appendix A. "Schematic and Layouts"](#) and [Appendix B. "Bill of Materials \(BOM\)"](#).

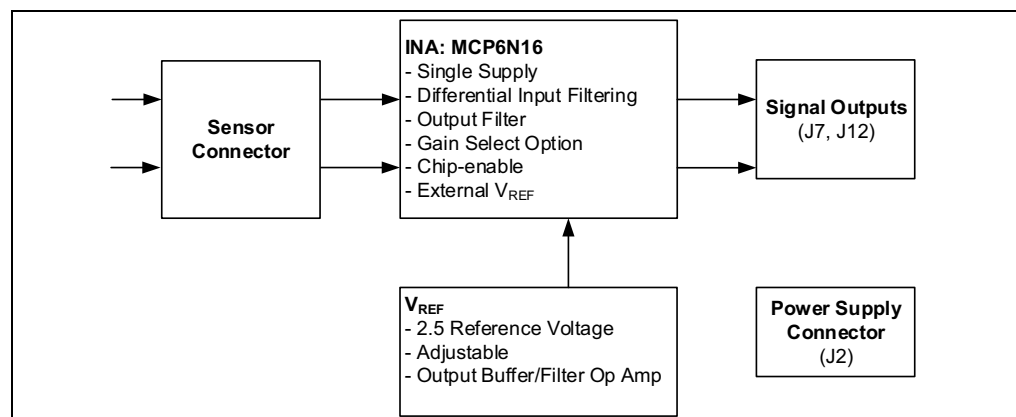

**FIGURE 1-1:** Overall Block Diagram.

# MCP6N16 Evaluation Board User's Guide

## 1.3.2 Sensor Connector

The sensor connector, J5, is a 6-pin screw terminal configured to accommodate a variety of sensors. Bridge-type sensors can have their excitation voltage connected to either the  $V_{DUT}$  supply of the evaluation board or to another externally-supplied source. In addition, the connector provides sense line connections.

## 1.3.3 Instrumentation Amplifier

The MCP6N16 is a zero-drift instrumentation amplifier designed for single-supply operation with rail-to-rail input (no common mode crossover distortion) and output performance. The device can be operated over a supply range of +1.8V to +5.5V ( $V_{DUT}$ ). The evaluation board is populated with the MCP6N16-100, which is designed to be operated with a gain of +100V/V and higher. At a gain of +100V/V, the MCP6N16-100 offers a typical input signal range of 34 mV<sub>P-P</sub>, with a maximum offset voltage of only 17  $\mu$ V. It offers a very low noise of 0.93  $\mu$ V<sub>P-P</sub> (0.1 to 10 Hz), and a voltage noise density of 45 nV/ $\sqrt{\text{Hz}}$ .

The RC input filter provides a low-pass function for both common mode (CM) and differential mode (DM) signals. They are fast enough to follow supply variations and to let the MCP6N16 reject CM mains noise (e.g., harmonics of 50 or 60 Hz). In its default setting, it is set to a gain of +101V/V; using jumper J9, it can be reconfigured for gain of +301V/V. The output filter provides a low-pass function for both CM and DM signals. It is slow in order to minimize noise and interference.

## 1.3.4 $V_{REF}$

The evaluation board uses the precision voltage reference IC MCP1525 to provide a +2.5V reference voltage ( $V_{REF}$ ) with an accuracy of better than 1%. This voltage can be adjusted and used as an external reference voltage for the MCP6N16 to level shift its output voltage to a desired level.

## 1.3.5 Power Supply Connector

The evaluation board allows for a number of supply configurations using connector J2. In its default configuration, the board can be operated with just one external lab supply voltage (Jumper J1 is installed and connects the  $V_{DUT}$  and  $V_{S+}$  lines together).

Shown in [Figure 1-2](#) and [Figure 1-3](#) are the 3D views of the evaluation board's top and bottom side. The evaluation board measures approximately 4.3" x 2.4" (10.9 cm x 6.1 cm).

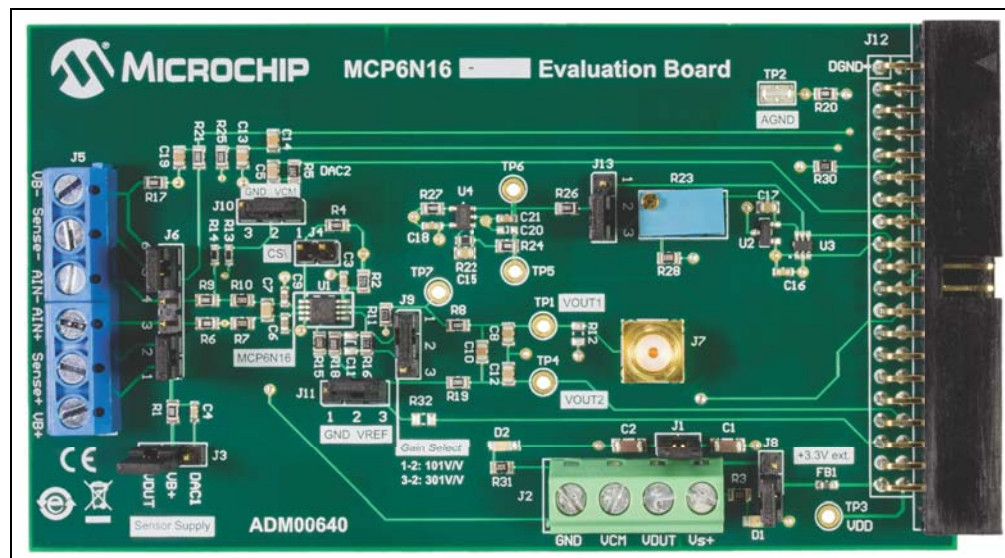

**FIGURE 1-2:** MCP6N16 Evaluation Board – Top View.

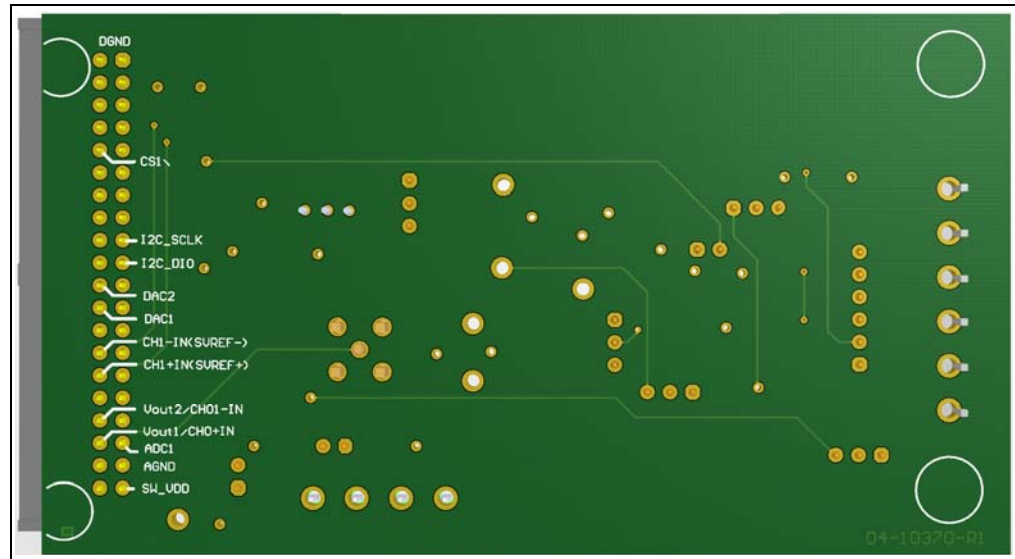

**FIGURE 1-3:** MCP6N16 Evaluation Board – Bottom View.

## 1.4 WHAT DOES THIS KIT CONTAIN?

The MCP6N16 Evaluation Board kit includes:

- MCP6N16 Evaluation Board (ADM00640)
- Important Information Sheet

# MCP6N16 Evaluation Board User's Guide

---

NOTES:

## Chapter 2. Installation and Operation

### 2.1 INTRODUCTION

This chapter shows how to set up and operate the MCP6N16 Evaluation Board. Items discussed in this chapter include:

- Required Tools
- Basic Configurations
- Detailed Circuit Descriptions

### 2.2 REQUIRED TOOLS

#### 2.2.1 Bench Setup

In order to operate the evaluation board on the lab bench, the following equipment and tools are required:

- MCP6N16 Evaluation Board
- Lab DC Power Supply with single output
  - Generates +5.0V typical (J2/3,  $V_{DUT}$ ) and ground (GND, J2/1)
- Voltmeter (Multimeter)
- Signal Generator to simulate a low-level sensor signal, or a suitable sensor
- Oscilloscope with high-impedance probe ( $\geq M\Omega$ )
- Optional: Signal Analyzer (network analyzer, spectrum analyzer, etc.)
  - High-input impedance ( $\geq 1 M\Omega$ )

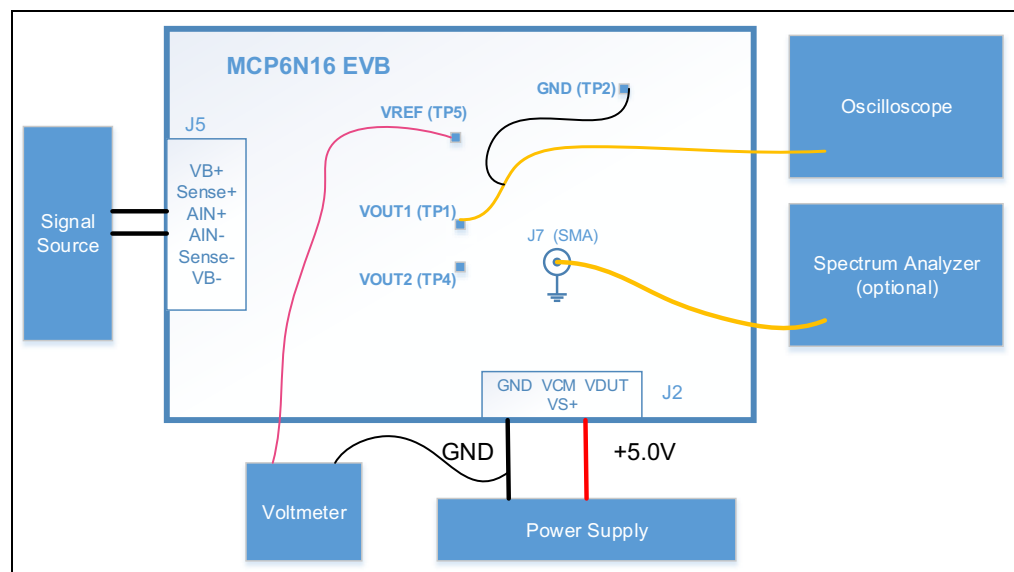

**FIGURE 2-1:** Basic Lab Bench Setup Example.

# MCP6N16 Evaluation Board User's Guide

## 2.3 BASIC CONFIGURATIONS

The following sections present various configurations supported by the MCP6N16 Evaluation Board.

### 2.3.1 Out of the Box Setup

The setup for these boards when they are shipped is as follows:

- Gain = 101V/V
- External  $V_{REF}$

Follow Step 1 through Step 4 to set up the evaluation board and get started (see [Figure 2-1](#)):

1. Connect a +5.0V supply to J2:  $V_{DUT}$  and GND.
2. Connect the inputs AIN+ and AIN- to an appropriate signal (e.g. 10 Hz sine wave, 10 mV<sub>PP</sub>).
3. Measure the DC voltage  $V_{REF}$  at TP5 with a voltmeter: it is suggested to set this to +2.5V (adjust with R23 if necessary) to level shift the output of the MCP6N16 centered between the supply rails.
4. Connect an oscilloscope to the output at either TP1 ( $V_{OUT}$ ) or J7 and observe the output signal of the MCP6N16.

### 2.3.2 Test Points

[Table 2-1](#) lists the test points and describes their functionality.

**TABLE 2-1: TEST POINTS**

Test Point			Comments
Ref. Des.	Label	I/O	
TP1	VOUT1	O	MCP6N16 filtered output signal voltage
TP2	AGND	—	Ground reference point (analog)
TP3	VDD	O	$V_{DD}$ (from the PIC <sup>®</sup> microcontroller) ( <a href="#">Note 1</a> )
TP4	VOUT2	O	MCP6N16, filtered $V_{REF}$ signal voltage
TP5	VREF	O	Buffered and filtered reference voltage
TP6	—	O	Unbuffered reference voltage
TP7	—	O	MCP6N16 output before filter

**Note 1:** Functional only when connected to PIC<sup>®</sup> device.



## 2.3.3 Jumper Settings

Table 2-2 shows the jumper settings.

**TABLE 2-2: JUMPER SETTINGS**

Jumper				Comments
Ref. Des.	Label	Position setting	Default setting	
J1		1 - 2	Closed	Connects $V_{DUT}$ and $VS+$ supply lines together
J3	Sensor supply	1 - 2	Closed	Use this setting to power the sensor with the $V_{DUT}$ supply.
		2 - 3	Open	Use this setting to supply sensor power from an external source (e.g. DAC1).
J4	CS	1 - 2	Open	Enable function (EN); use to place the MCP6N16 into power-down by installing this jumper.
J6		1 - 2	Closed	Connects the SENSE+ line to the VB+ line
		5 - 6	Closed	Connects the SENSE- line to the VB- line
		3 - 4	Open	Optional: when installed shortens the AIN+ and AIN- inputs together. May be used for diagnostic purposes.
J8	+3.3V ext.	1 - 2	Open	Use only when power will be supplied by the PIC <sup>®</sup> microcontroller attached through J12. Not needed for stand-alone bench operation.
J9	Gain Select	1 - 2	Closed	Configures the MCP6N16 for a gain of +101V/V
		2 - 3	Open	Configures the MCP6N16 for a gain of +301V/V
J10	VCM	1 - 2	Closed	Connects the external $V_{CM}$ (from J2) to the signal inputs through R13 and R14
		2 - 3	Open	Use this to provide a DC-path for the INA inputs when the signal is AC-coupled. ( <a href="#">Section 2.4.3.1 "Input AC-Coupling"</a> )
J11	VREF	1 - 2	Open	Use this to reference $V_{REF}$ pin of the MCP6N16 to ground
		2 - 3	Closed	In this setting the output of the MCP6N16 will be level shifted by the external $V_{REF}$ voltage.
J13		1 - 2	Open	Use this setting in conjunction with the DigiPot MCP4018. This function is only available when the PIC <sup>®</sup> microcontroller is attached at J12.
		2 - 3	Closed	Connects the adjustable reference voltage to the buffer amp U4

# MCP6N16 Evaluation Board User's Guide

## 2.4 DETAILED CIRCUIT DESCRIPTIONS

### 2.4.1 Power Supply

When in its default configuration, the evaluation board requires only one external power supply, typically a +5.0V single supply voltage applied to pin 3 (or 4) of the 4-pin screw terminal J2. The ground connection (GND) should be made to pin 1 of J2; see [Figure 2-1](#).

- Note 1:** Jumper J1 is installed by default and therefore shorts the  $V_{DUT}$  and  $VS+$  supply voltage connections together. In this configuration, the evaluation board can be operated with full functionality within a voltage range of +2.7V to +5.5V.
- 2:** Removing jumper J1 will necessitate a second external power supply to maintain full operation of the evaluation board. This will allow the MCP6N16 to be operated over its full supply range of +1.8V to +5.5V. The  $VS+$  supply should not be lower than +2.7V, in order to maintain operation of the +2.5V precision reference IC MCP1525.

The LEDs D1 and D2 will indicate that power is applied to the  $V_{DUT}$  and  $VS+$  supplies.

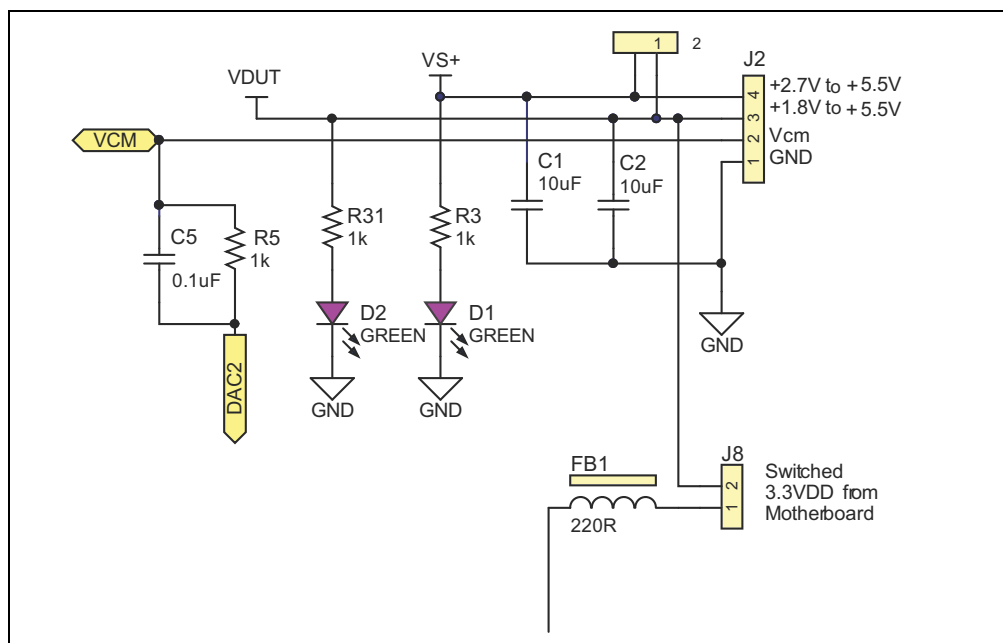

**FIGURE 2-2:** Power Supply Circuit and Connections.

The power plane of the evaluation board is separated into two segments: one labeled  $V_{DUT}$  and one  $VS+$ . The  $V_{DUT}$  supply line mainly powers the MCP6N16 instrumentation amplifier. It is also connected to be the supply rail for any attached bridge sensor ( $VB+$ ,  $VB-$ ). The  $VS+$  supply powers the precision voltage reference MCP1525, and the Zero-Drift op-amp MCP6V11.

The evaluation board is also preconfigured to be operated from a +3.3V supply rail when connected up to a PIC<sup>®</sup> microcontroller. Jumper 8 is needed to make this connection, while any external lab supplies must be disconnected from the power connector J2.

In addition to connecting the supply voltages, pin 2 of terminal J2 can be used to apply an external common-mode voltage ( $V_{CM}$ ) for biasing the inputs of the instrumentation amplifier MCP6N16 (see [Figure 2-2](#)). Further details on this function can be found in [Section 2.4.3 “Instrumentation Amplifier”](#).

## 2.4.2 Sensor Connection

The evaluation board provides a 6-pin screw terminal to allow for a variety of sensors to be connected, and, based on the specific sensor, the user can select either a 2-, 3-, 4- or 6-wire interface configuration. Figure 2-3 shows the screw-terminal with its pin descriptions: AIN+ and AIN- are the differential signal inputs for the instrumentation amplifier. To facilitate a quick noise test, install a jumper on J6 that will shorten the AIN+ and AIN- lines together.

**Note:** The evaluation board comes with the MCP6N16 device set for a gain of 101V/V; when operating with a +5.0V supply rail the typical full-scale input range of the MCP6N16-100 is about 34 mV<sub>P-P</sub>.

VB+ and VB- are the two connections for the excitation voltage for the sensor (usage depends on sensor type). In its standard configuration, a jumper is installed at J3, connecting the supply voltage  $V_{DUT}$  to VB+ (typically +5.0V). Resistor R1 and R17 allow for any additional series resistance to be added into the sensor excitation lines. An additional option for providing excitation is through the DAC1 line by using an external supply (e.g. current source) or stimulus. For this, jumper J3 needs to be adjusted accordingly. Another option for the user is to superimpose an AC signal (through C4) onto a DC excitation voltage to simulate an AC error signal that the sensor might pick up and examine the common-mode rejection behavior of the filters and instrumentation amplifier.

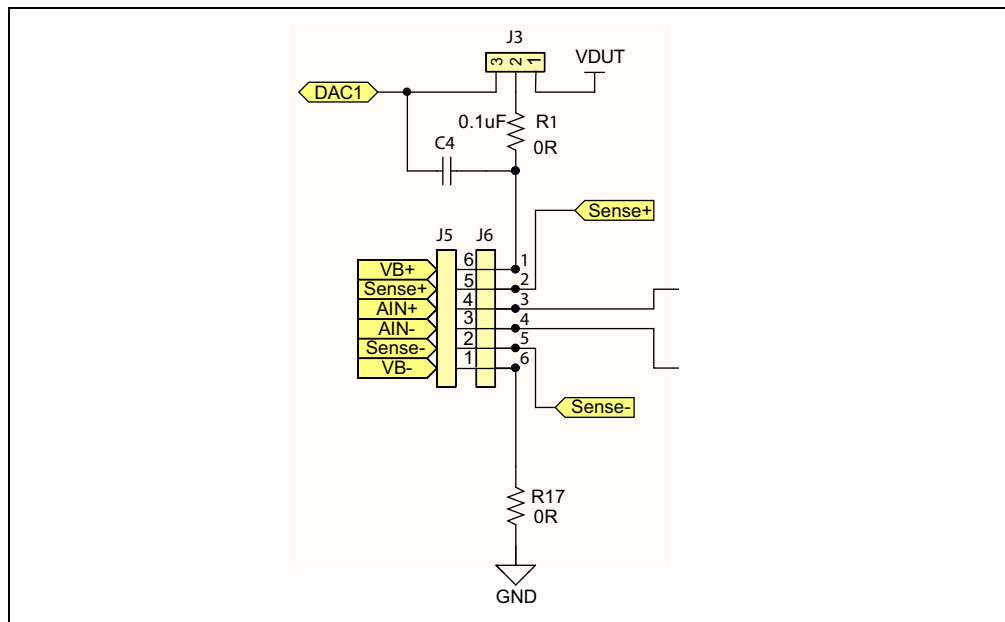

**FIGURE 2-3:** Sensor Connections.

# MCP6N16 Evaluation Board User's Guide

## 2.4.2.1 EXAMPLE: 4-WIRE LOAD CELL

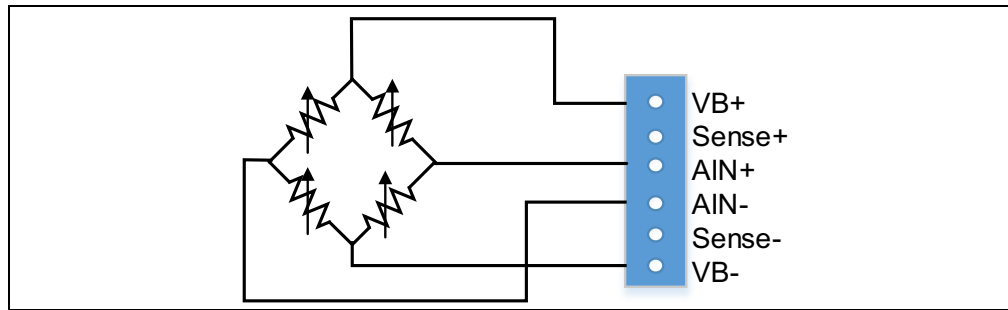

**FIGURE 2-4:** Connecting Diagram for a 4-Wire Load Cell.

The SENSE+ and SENSE- lines can be used for a 6-wire sensor interface. In its default configuration, the jumper installed at J6, connects Sense+ to VB+ and Sense- to VB-. As shown in [Figure 2-5](#), the sense lines have an additional set of common- and differential-mode RC filters similar to the AIN+ and AIN- lines.

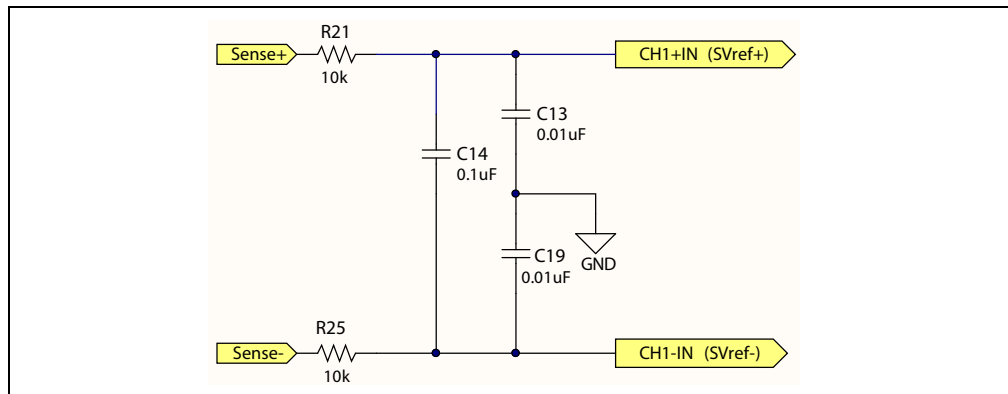

**FIGURE 2-5:** Sense Line Connections.

## 2.4.3 Instrumentation Amplifier

The MCP6N16 is a zero-drift instrumentation amplifier designed for single-supply operation with rail-to-rail input (no common mode crossover distortion) and output performance. Its design is based on a current feedback architecture which allows for the output voltage to be independently set regardless of the input common-mode voltage. The gain of the instrumentation amplifier is set by two external resistors, but unlike most INAs, the gain accuracy of the MCP6N16 is only determined by the relative match of those external resistors ( $R_F$  and  $R_G$ ). Refer to the MCP6N16 data sheet for more details on its operation and specifications.

## 2.4.3.1 INPUT AC-COUPLING

With resistors R6 and R9 (both 0Ω) populated, the signal inputs on the evaluation board are DC coupled to the inputs of the instrumentation amplifier MCP6N16. Alternatively, the inputs can be configured for AC coupling. For this, replace resistors R6 and R9 with ceramic capacitors (0.1 μF, or as required). In this AC-coupling configuration, it is important to provide a DC bias path for the inputs of the instrumentation amplifier. This is accomplished with resistors R13 and R14, which are already installed. They can be either referenced to ground or an external common-mode voltage ( $V_{CM}$ ) by setting the jumper J10 accordingly. The resistor along with the coupling capacitors will also result in a high-pass filter; for example using 0.1 μF capacitors and 200 kΩ resistor will set the -3 dB frequency at about 8 Hz.

**Note:** When using resistors R13 and R14, the input impedance at the AIN+ and AIN- is determined by the value of these resistors. Removing the resistors will restore the high input impedance provided by the MCP6N16, but will also eliminate the option of using an external common-mode voltage ( $V_{CM}$ ) through J2.

## 2.4.3.2 INPUT AND OUTPUT FILTERING

The MCP6N16 features internal EMI filters on all four of its inputs that are very effective suppressing high-frequency signals from interfering and causing unwanted offset voltages. Those internal filters may already be sufficient for some applications and the sensor can be connected directly to the inputs of the MCP6N16. The evaluation board includes additional external RC filtering comprised of common-mode and differential-mode filters which will limit the input signal bandwidth according to [Equation 2-1](#).

### EQUATION 2-1:

$$\text{Common-Mode filter: } f_{CM} = \frac{1}{(2\pi R7 \times C6)} = \frac{1}{(2\pi R10 \times C9)}$$

Note that capacitors C6 and C9 have been selected with a lower tolerance of 5%, instead of the typical 10%, to improve time constant matching between R7C6 and R10C9 and consequently limit the CMRR degradation caused by such mismatches. The -3 dB frequency for these filters is about 8 kHz. The MCP6N16-100 maintains a very high common-mode rejection, CMRR of > 100 dB out to 100 kHz. This allows for a relatively high corner frequency to be chosen for this filter and therefore reduces the series resistor (i.e. R7 and R10) value, which may otherwise cause unwanted offset and noise contributions at the input of the high-gain instrumentation amplifier.

It is recommended to keep the value of C7 at least ten times larger than C6 and C9 to reduce the effects of the time constant mismatch and improve performance.

### EQUATION 2-2:

$$\text{Differential-Mode filter: } f_{DIFF} = \frac{1}{(2\pi (R7 + R10) \left( C7 + \frac{C6}{2} \right))}$$

$$\text{with } R7 = R10: f_{DIFF} = \frac{1}{(2\pi R(2C7 + C6))}$$

The differential-mode input filter has its -3 dB frequency corner at about 378 Hz. Note that the filter will start affecting the gain at a much lower frequency, for example the input signal will be lowered by 1% at about 54 Hz.

# MCP6N16 Evaluation Board User's Guide

The complete frequency response of the signal path consisting of the input filter, MCP6N16 and the output filter is shown in Figure 2-6. Here, the -3 dB frequency corner is at approximately 300 Hz with a flat gain out to about 30 Hz.

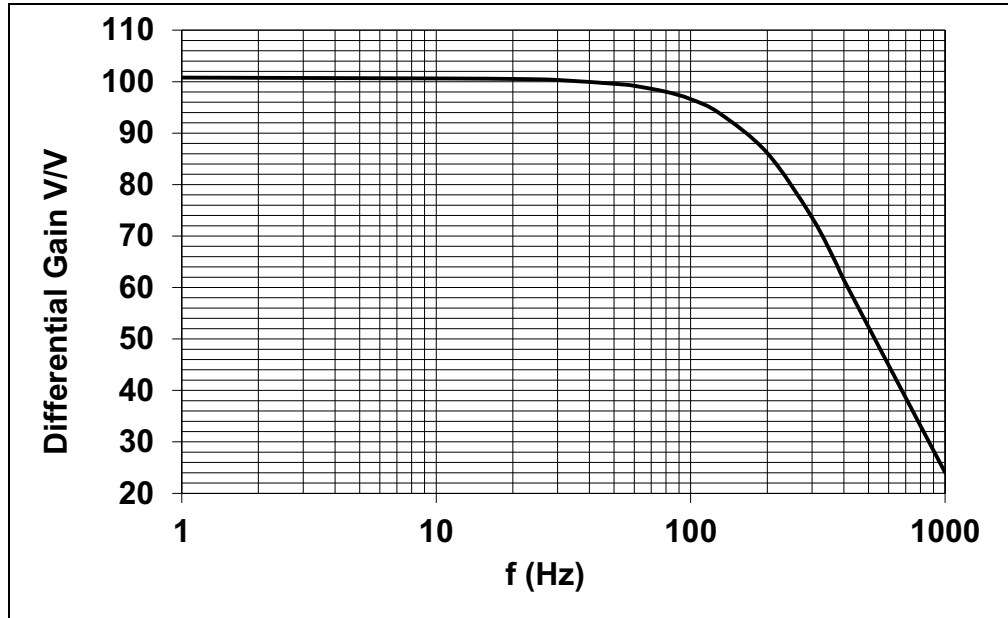

**FIGURE 2-6:** Frequency Response of the Complete Signal Path for a Differential Gain of 101V/V.

Figure 2-7 shows the signal path including the input and output RC filters of the MCP6N16. The RC output filter is similar to the input filter with the exception that the common-mode pole is set at about 1.59 kHz and the differential pole is at about 756 Hz. Once the actual nature of the sensor/input signal and its bandwidth is known, the filter poles can be adjusted to limit further the noise-bandwidth and to optimize the interface to an A/D converter that may follow.

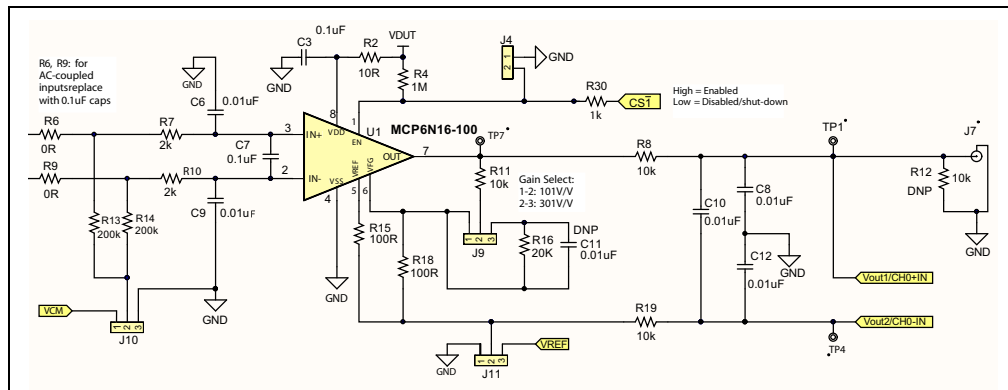

**FIGURE 2-7:** Instrumentation Amplifier MCP6N16 Signal Path Circuitry.

## 2.4.3.3 INA GAIN SELECTION

The evaluation board allows users to quickly set the gain on the MCP6N16 to either 101V/V or 301V/V by setting the jumper on J9 (labeled Gain Select) accordingly. Note that the feedback resistors R11 and R16 are populated with a tolerance of only 0.1% (instead of the standard 1%) to provide a higher gain accuracy. The gain is set with two external resistors and follows the relationship shown in [Equation 2-3](#).

### EQUATION 2-3:

$$\text{Differential Signal Gain: } G_1 = 1 + \frac{R11}{R18} = 101$$

$$G_2 = \frac{1 + (R11 + R16)}{R18} = 301$$

The transfer function of the MCP6N16 is given as shown in [Equation 2-4](#).

### EQUATION 2-4:

$$V_{OUT} = G (V_{IP} - V_{IM}) + V_{REF}$$

[Table 2-3](#) lists suggested resistor values for the feedback ( $R_F$ ) and gain resistors ( $R_G$ ), using 1% standard resistor, for a desired gain. Large value resistors should be avoided as they may start to contribute noise. To keep the output loading minimal and maintain optimum linearity the selection of the gain setting resistors should take any additional load resistance into account, according to [Equation 2-5](#).

### EQUATION 2-5:

$$(R_F + R_G) || R_L \geq 10 \text{ k}\Omega$$

**TABLE 2-3: SUGGESTED RESISTOR VALUES FOR VARIOUS GAINS**

Gain (V/V)	R <sub>F</sub> (Ohm, 1%)	R <sub>G</sub> (Ohm, 1%)	MCP6N16-001	MCP6N16-010	MCP6N16-100
1	Short	None	Yes	No	No
2	10 kΩ	10 kΩ	Yes	No	No
5	20 kΩ	4.99 kΩ	Yes	No	No
10.1	9.09 kΩ	1 kΩ	Yes	Yes	No
20.1	19.1 kΩ	1 kΩ	Yes	Yes	No
49.7	24.3 kΩ	499Ω	Yes	Yes	No
101	10 kΩ	100Ω	Yes	Yes	Yes
301	30 kΩ	100Ω	Yes	Yes	Yes
500	24.9 kΩ	49.9Ω	Yes	Yes	Yes
1001	49.9 kΩ	49.9Ω	Yes	Yes	Yes

**Note:** The MCP6N16-100 is internally compensated to be used for gains higher or equal to 100. If lower gains are desired, consider using alternate models, for example the MCP6N16-010 for gains higher or equal to 10, or the MCP6N16-001 for gains higher or equal to 1.

Capacitor C11 in combination with R16 can be added to the feedback network to form an additional low-pass filter of approximately 800 Hz (with C11 = 0.01 μF). This may be used as an alternate filter option instead of the common/differential-mode RC filter at the output of the MCP6N16 consisting of R8, R19, C8, C10, C12.

# MCP6N16 Evaluation Board User's Guide

## 2.4.3.4 ENABLE FUNCTION

The MCP6N16 instrumentation amplifier features an Enable-pin (EN); since there is no internal pull-up resistor, the MCP6N16 on the evaluation board is placed into the Enable state (operational) by an external pull-up resistor (R4). The evaluation board provides two options for the user to examine the part's performance in its power-down state: either in a static mode, by inserting a jumper on J4, or through the CS1 line. If this line is connected to an external stimulus (CMOS levels), the dynamic performance can be examined.

## 2.4.4 External $V_{REF}$ Circuit

Included on the evaluation board are various options that deliver an external reference voltage to the MCP6N16, which can be used to level shift the output signal. Since the MCP6N16 is configured in a single-supply configuration on the evaluation board, either the input is biased with an appropriate input DC bias voltage to keep the amplifier within its specified input range, or the output needs to be level shifted. Refer to the MCP6N16 data sheet for further details.

The MCP1525 (U2) is a precision, low-power voltage reference with an output voltage of +2.5V. Resistor R23 is a 25-turn potentiometer that is used to provide an adjustment range of +0.025V to +3.0V at the output of the reference buffer U4. The buffer amplifier uses the MCP6V11, a zero-drift micro-power operational amplifier that is configured for a gain of +1.2V/V. To minimize noise the bandwidth of this amplifier stage is limited to about 8 Hz using capacitor C15, which is placed in parallel with the feedback resistor.

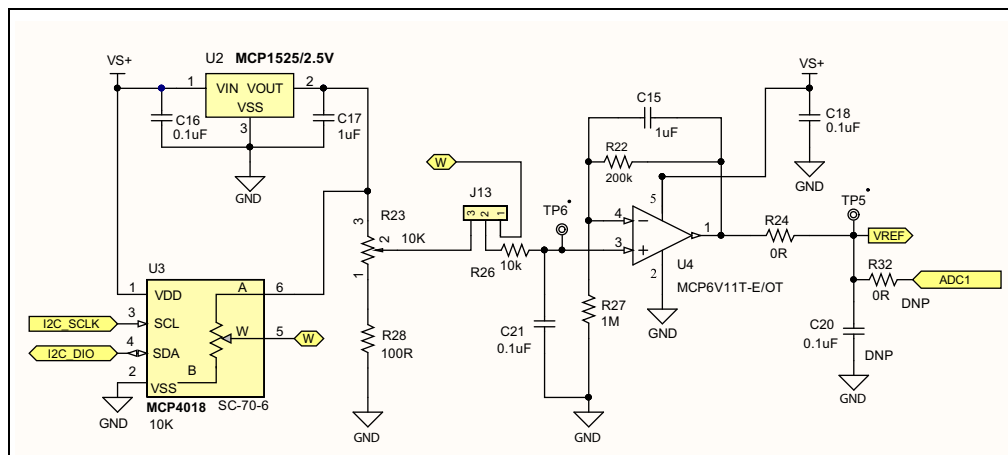

**FIGURE 2-8:** External Precision Voltage Reference Circuitry.

An alternate method to adjusting the reference voltage manually with R23 is offered with the Digital Potentiometer device MCP4018. The use of this device will require the user to connect the MCP4018 I<sup>2</sup>C™ interface to an external controller (e.g. a PIC microcontroller). Jumper J13 is used to switch between the manual option on the MCP4018.



## 2.4.5 PIC<sup>®</sup> Microcontroller Analog/Digital Interface

The MCP6N16 Evaluation Board is preconfigured to interface with a microcontroller, for example the PIC24FJ128GC010, which includes 16-Bit Sigma-Delta ADCs. For more information please refer to the *"MPLAB<sup>®</sup> Starter Kit for Intelligent, Integrated, Analog User's Guide"* (DS50002172) and AN1607 Application Note – *"PIC24FJ128GC010 Analog Design Guide"* (DS00001607). The 40-pin dual row header (J12) connects to various nodes of the MCP6N16 circuit and places them in one convenient place. In order to utilize this interface, the user will need to select the desired microcontroller and design the necessary interface hardware and software/firmware.

Another option to interface with the I<sup>2</sup>C of the MCP4018 DigiPot is to utilize the *"PICkit<sup>™</sup> Serial Analyzer User's Guide"* (DS51647).

# MCP6N16 Evaluation Board User's Guide

---

NOTES:



# MCP6N16 EVALUATION BOARD USER'S GUIDE

---

---

## Appendix A. Schematic and Layouts

---

---

### A.1 INTRODUCTION

This appendix contains the following schematics and layouts for the MCP6N16 Evaluation Board.

- Board – Schematic
- Board – Top Silk
- Board – Top Copper and Silk
- Board – Top Copper
- Board – Bottom Copper
- Board – Bottom Copper and Silk
- Board – Bottom Silk

## A.2 BOARD – SCHEMATIC

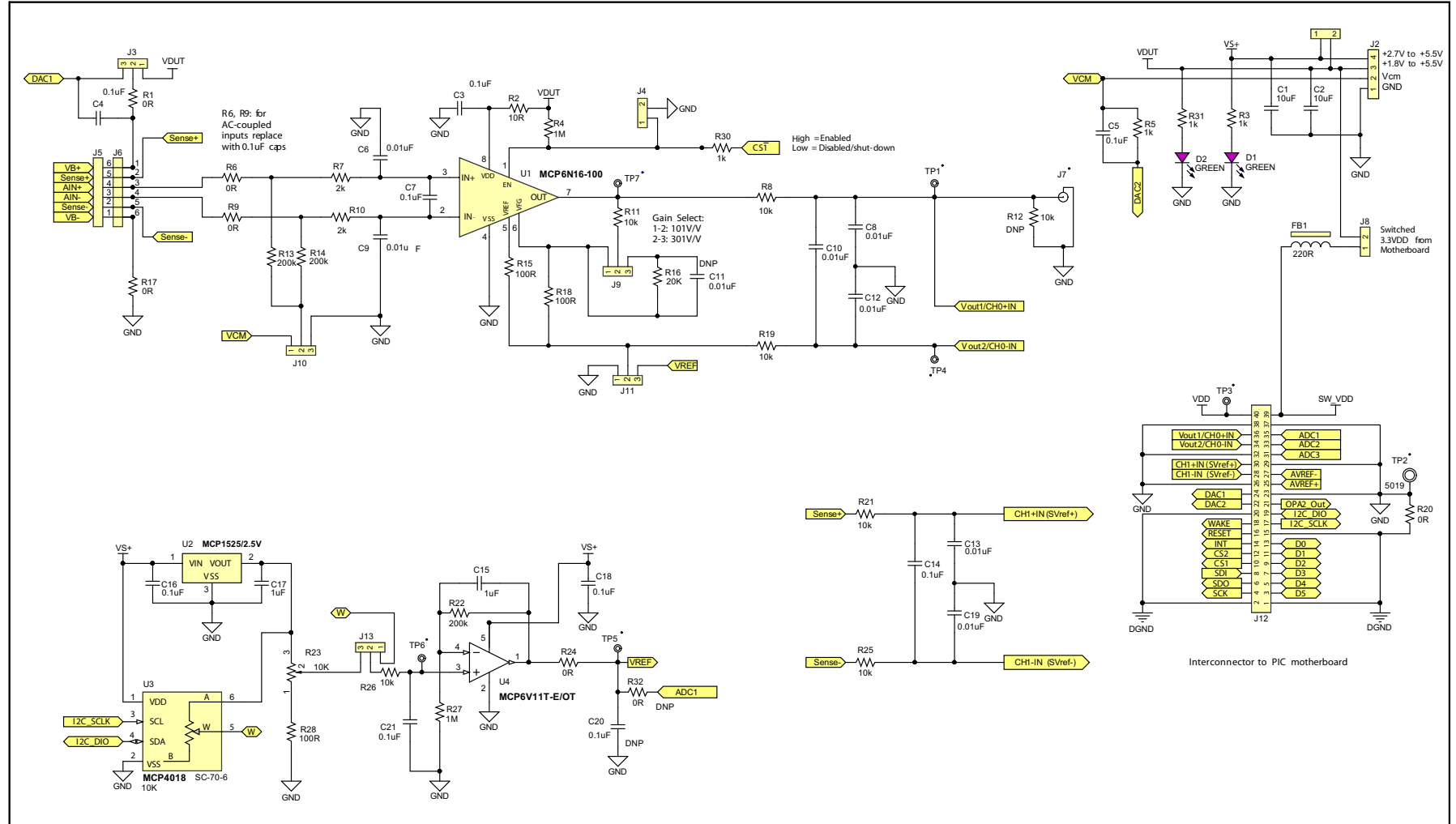

## A.3 BOARD – TOP SILK

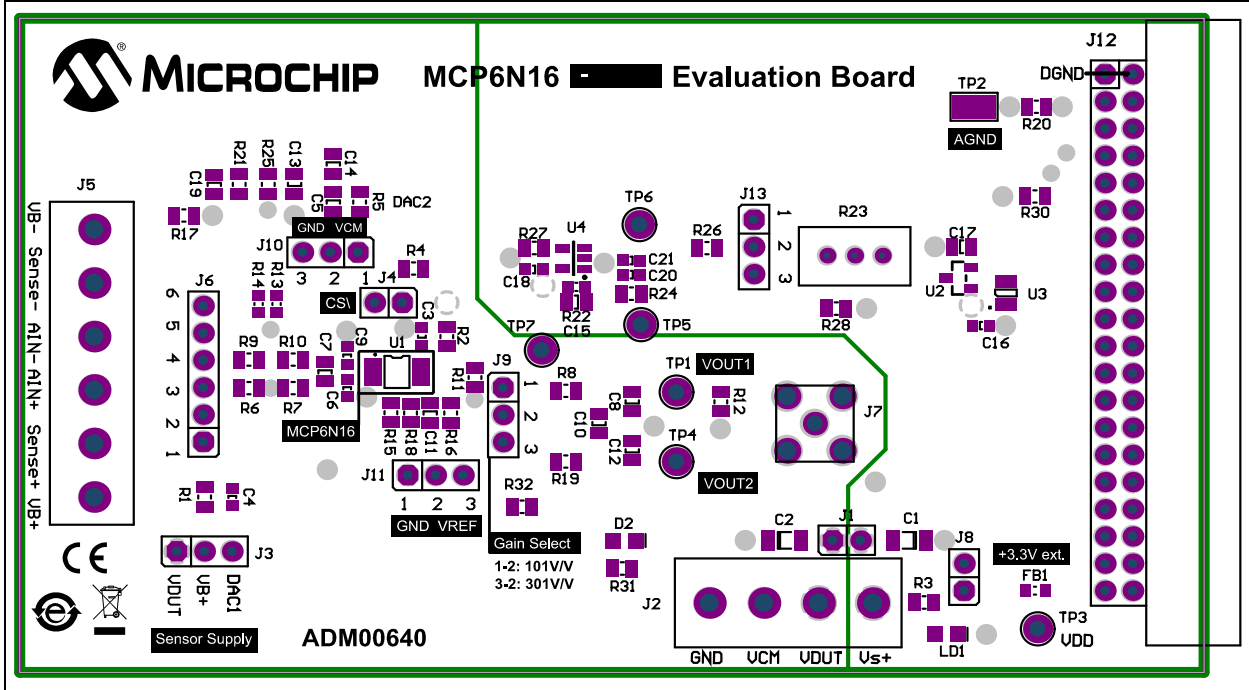

## A.4 BOARD – TOP COPPER AND SILK

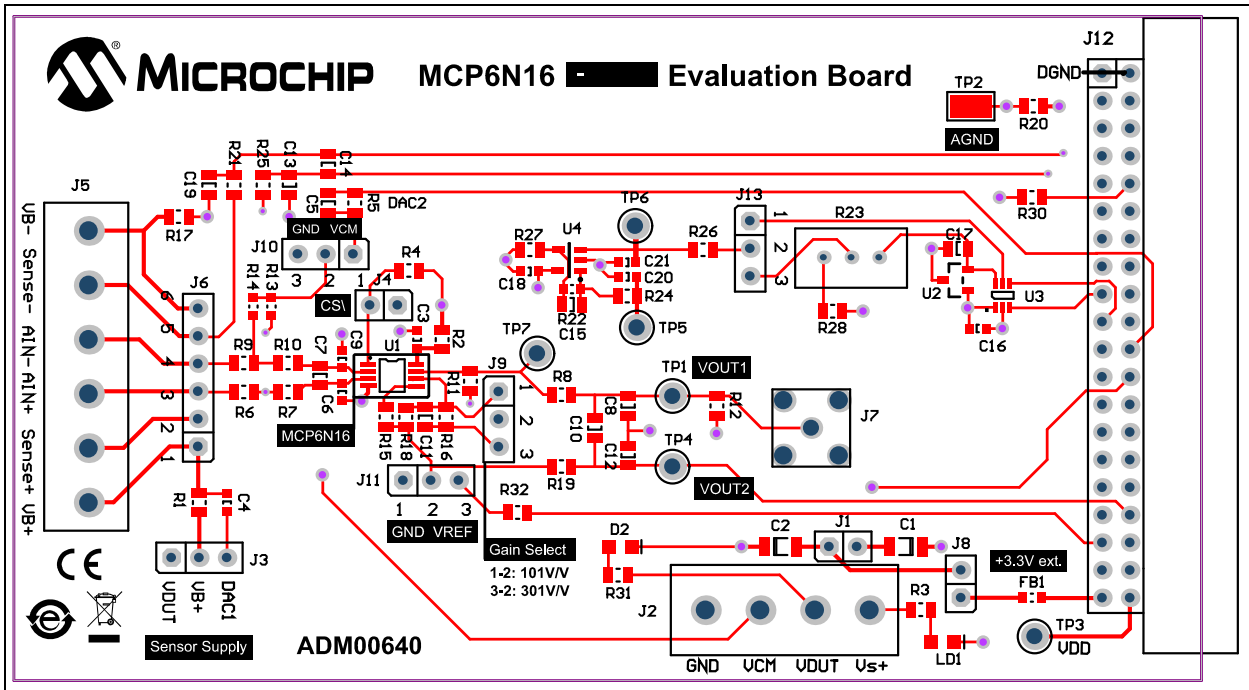

# MCP6N16 Evaluation Board User's Guide

## A.5 BOARD – TOP COPPER

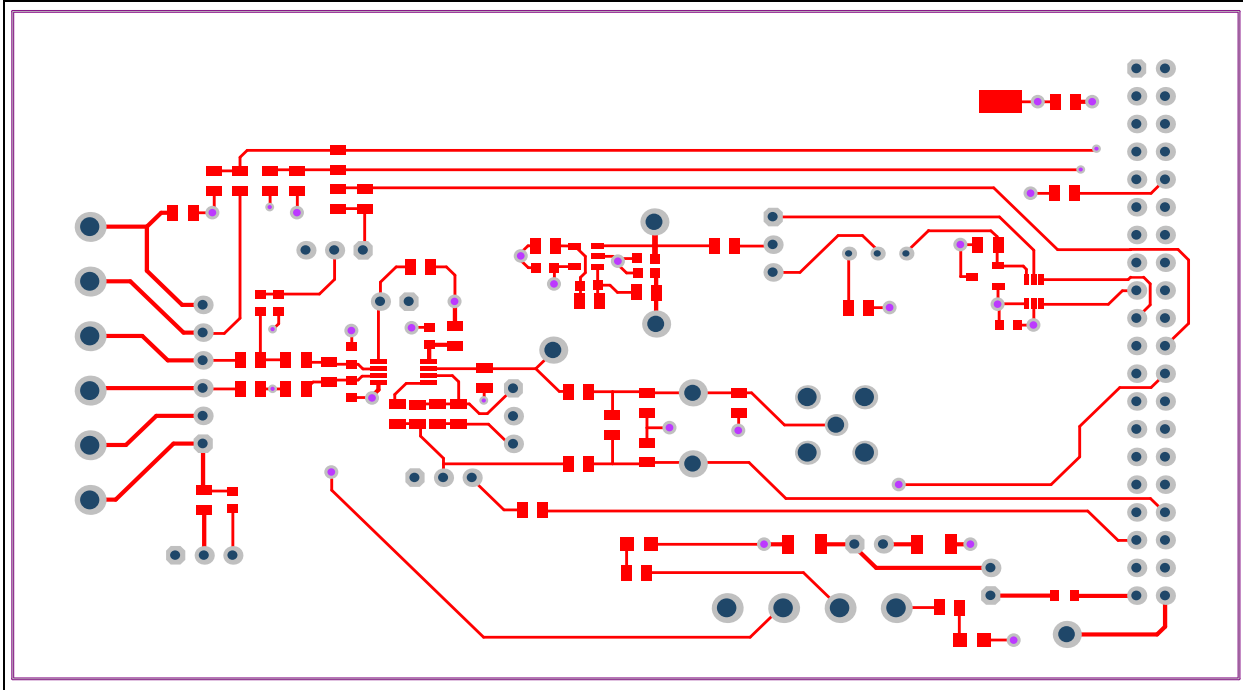

## A.6 BOARD – BOTTOM COPPER

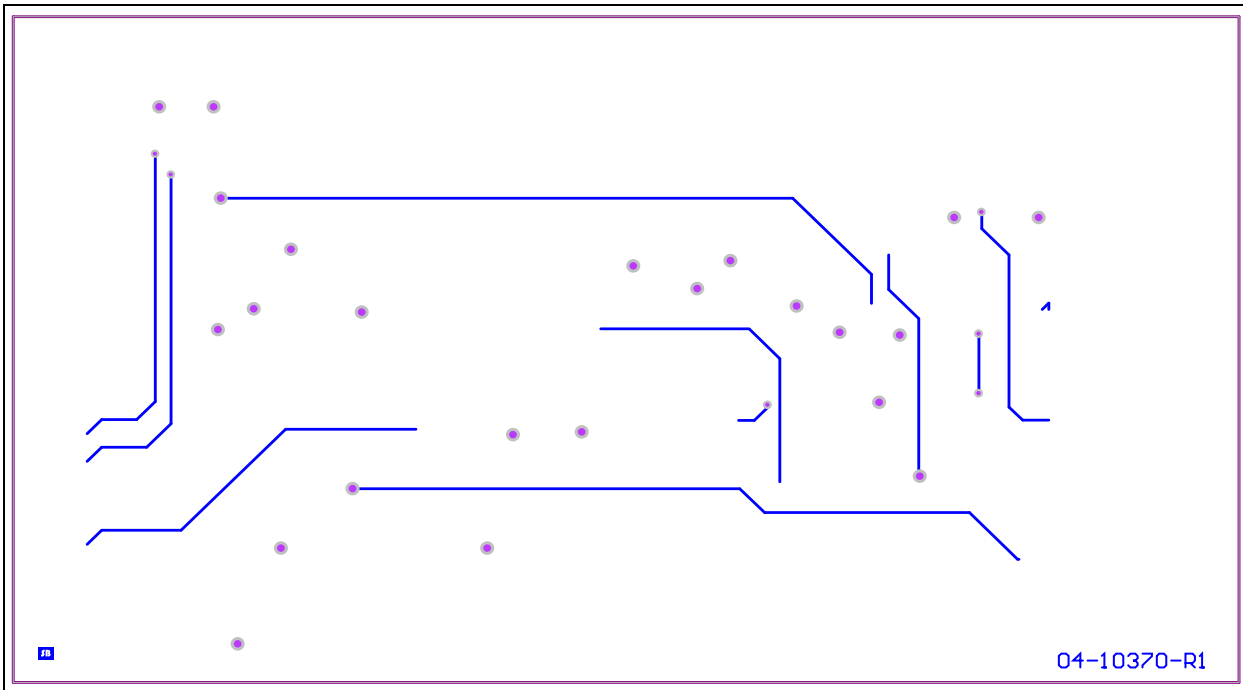

## A.7 BOARD – BOTTOM COPPER AND SILK

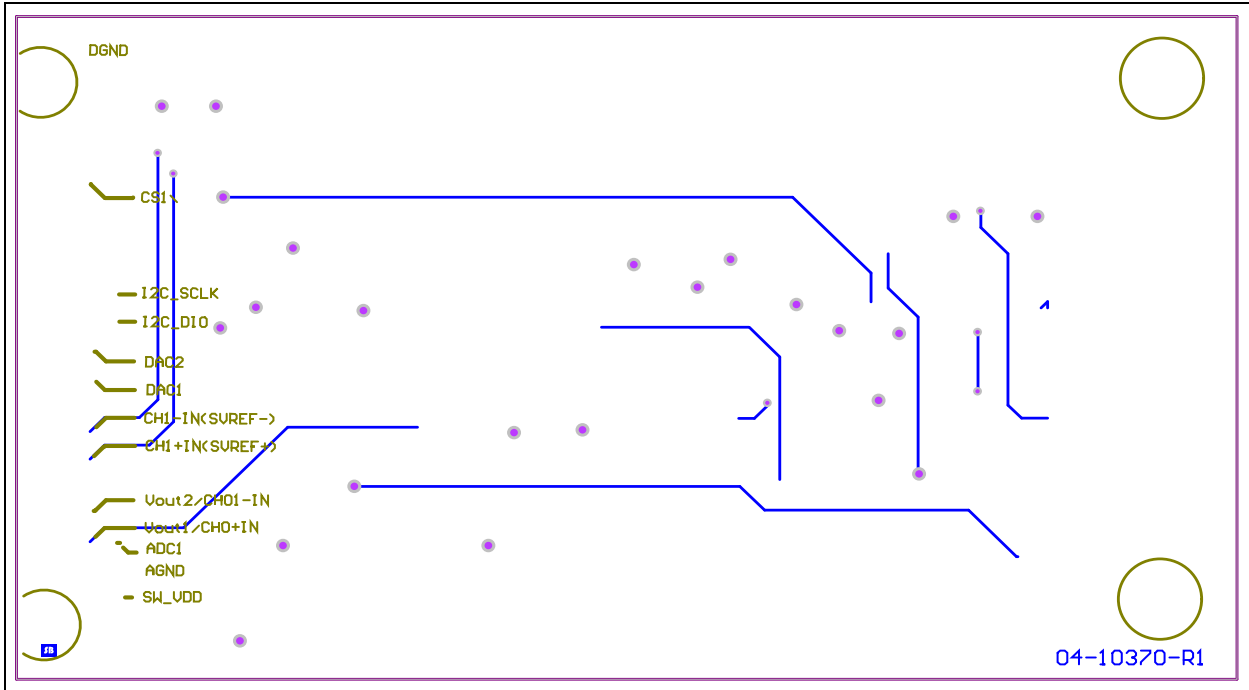

## A.8 BOARD – BOTTOM SILK

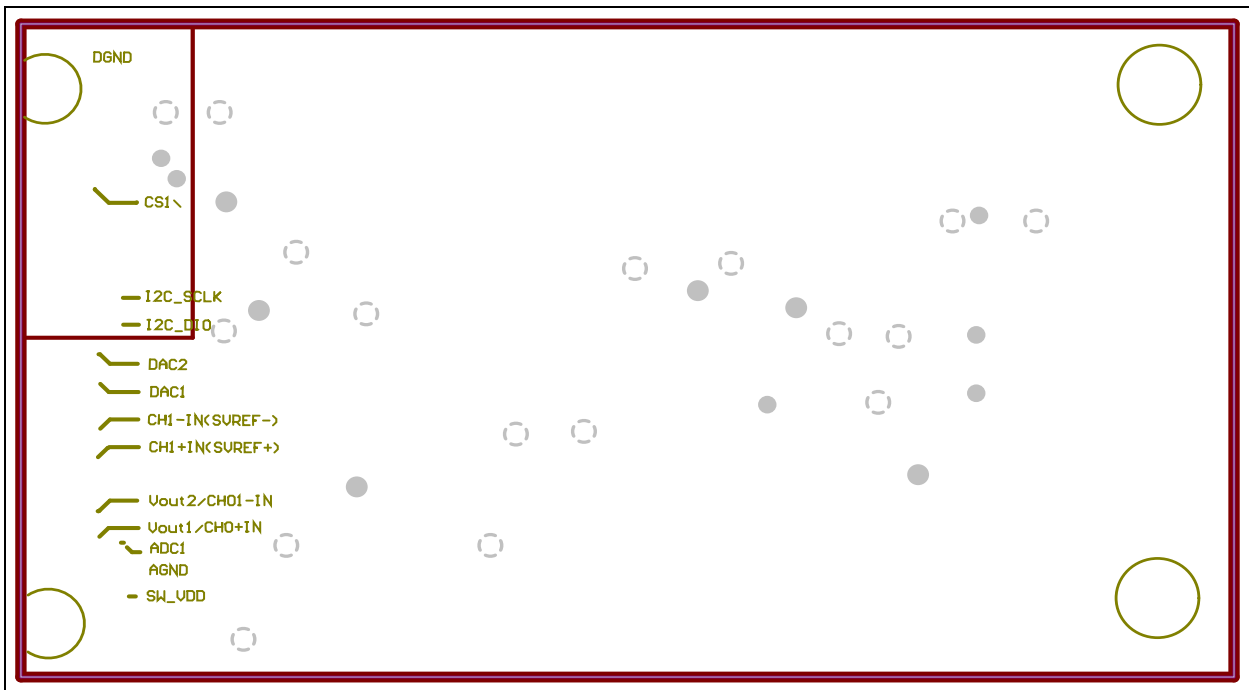

# MCP6N16 Evaluation Board User's Guide

---

NOTES:



## Appendix B. Bill of Materials (BOM)

### B.1 MCP6N16 EVALUATION BOARD BILL OF MATERIALS (BOM)

Table B-1 shows components installed on the PCB. Table B-2 shows the alternate components that the user may wish to acquire and install.

**TABLE B-1: BILL OF MATERIALS FOR ASSEMBLED PCB (BOM)**

Qty.	Reference	Description	Manufacturer	Part Number
2	C1, C2	Cap. ceramic 10 $\mu$ F 16V 10% X5R SMD 1206	TDK Corporation	C3216X5R1C106K
5	C3, C4, C16, C18, C21	Cap. ceramic 0.1 $\mu$ F 16V 10% X7R SMD 0603	AVX Corporation	0603YC104KAT2A
3	C5, C7, C14	Cap. ceramic 0.1 $\mu$ F 25V 10% X7R SMD 0805	Murata Electronics®	GRM21BR71E104KA01L
2	C6, C9	Cap. ceramic 0.01 $\mu$ F 16V 5% SMD 0603	Taiyo Yuden Co., Ltd.	EMK107SD103JA-T
5	C8, C10, C12, C13, C19	Cap. ceramic 0.01 $\mu$ F 50V 10% X7R SMD 0805	Murata Electronics	GRM40-X7R103K050BD
2	C15, C17	Cap. ceramic 1 $\mu$ F 10V 10% X7R SMD 0805	NIC Components	NMC0805X7R105K10TRPF
2	D1, D2	Diode LED green 2.1V 20 mA 6 mcd Diffuse SMD 0805	CML Technologies GmbH & Co. KG	7012X5
1	FB1	Ferrite 500 mA 220R SMD 0603	Murata Electronics	BLM18AG221SN1D
3	J1, J4, J8	Conn. Hdr.-2.54 male 1x2 gold 5.84 MH TH vert.	FCI	77311-118-02LF
1	J2	Conn. terminal 5 mm 10A female 1x4 TH R/A	PHOENIX CONTACT	1729034
5	J3, J9, J10, J11, J13	Conn. Hdr.-2.54 male 1x3 gold 5.84MH TH vert.	FCI	68000-103HLF
1	J5	Conn. terminal 5 mm 15A female 1x6 TH R/A	On-Shore Technology Inc.	ED500/6DS
1	J6	Conn. Hdr.-2.54 male 1x6 gold 5.84MH TH vert.	FCI	68001-106HLF
1	J7	Conn. RF coaxial SMA female 2P TH vert.	Amphenol Commercial	901-144-8RFX
1	J12	Conn. Hdr. 2.54 MM 40 POS gold R/A	Sullins Connector Solutions	SBH11-PBPC-D20-RA-BK
9	JP1, JP2, JP3, JP4, JP5, JP6, JP7, JP8, JP9	Mech. HW jumper 2.54 mm 1x2	3M	969102-0000-DA
4	PAD1, PAD2, PAD3, PAD4	Mech. HW rubber pad cylindrical D7.9 H5.3 black	3M	SJ61A11

**Note:** The components listed in this Bill of Materials are representative of the PCB assembly. The released BOM used in manufacturing uses all RoHS-compliant components.

# MCP6N16 Evaluation Board User's Guide

**TABLE B-1: BILL OF MATERIALS FOR ASSEMBLED PCB (BOM) (CONTINUED)**

Qty.	Reference	Description	Manufacturer	Part Number
1	PCB	Printed Circuit Board – MCP6N16 Evaluation Board	Microchip Technology Inc.	04-10370
6	R1, R6, R9, R17, R20, R24	Res. TKF 0R 1/8W SMD 0805	Panasonic® – ECG	ERJ-6GEY0R00V
1	R2	Res. TKF 10R 5% 1/8W SMD 0805	Yageo Corporation	9C08052A10R0JLHFT
4	R3, R5, R30, R31	Res. TKF 1 kΩ 5% 1/16W SMD 0805	Stackpole Electronics, Inc.	RMCF 1/10 1K 5% R
2	R4, R27	Res. TKF 1M 1% 1/8W SMD 0805	Panasonic – ECG	ERJ-6ENF1004V
2	R7, R10	Res. TKF 2 kΩ 1% 1/8W SMD 0805	Panasonic – ECG	ERJ-6ENF2001V
5	R8, R19, R21, R25, R26	Res. TKF 10 kΩ 1% 1/8W SMD 0805	Panasonic – ECG	ERJ-6ENF1002V
1	R11	Res. TF 10 kΩ 0.1% 1/16W SMD 0805	Panasonic – ECG	ERA-6YEB103V
3	R13, R14, R22	Res. TKF 200 kΩ 1% 1/10W SMD 0603	Panasonic – ECG	ERJ-3EKF2003V
3	R15, R18, R28	Res. TKF 100R 1% 1/16W SMD 0805	Stackpole Electronics, Inc.	RMCF 1/10 100 1% R
1	R16	Res. 20 kΩ 1/8W 0.1% 0805 SMD	Panasonic – ECG	ERA-6YEB203V
1	R23	Res. trimmer Cermet 10 kΩ 10% 500 mW TH 3296W	Murata Electronics	PV36W103C01B00
1	TP2	Conn. TP tab silver mini 3.8x2.03 SMD	Keystone Electronics	5019
1	U1	Zero-Drift instr. amplifier, GMIN = 100, MSOP-8	Microchip Technology Inc.	<b>MCP6N16-100E/MS</b>
1	U2	2.5V Precision voltage reference SOT23-5	Microchip Technology Inc.	<b>MCP1525T-I/TT</b>
1	U3	Digital potentiometer 1-ch, 10 kΩ, SC70-6	Microchip Technology Inc.	<b>MCP4018T-103E/LT</b>
1	U4	Zero-Drift 80 kHz op amp, SOT23-5	Microchip Technology Inc.	<b>MCP6V11T-E/OT</b>

**Note:** The components listed in this Bill of Materials are representative of the PCB assembly. The released BOM used in manufacturing uses all RoHS-compliant components.

**TABLE B-2: BILL OF MATERIALS FOR ALTERNATE COMPONENTS**

Qty.	Reference	Description	Manufacturer	Part Number
1	U1	Zero-Drift instr. amplifier, GMIN = 10, MSOP-8	Microchip Technology Inc.	<b>MCP6N16-010E/MS</b>
		Zero-Drift instr. amplifier, GMIN = 1, MSOP-8		<b>MCP6N16-001E/MS</b>

**Note:** The components listed in this Bill of Materials are representative of the PCB assembly. The released BOM used in manufacturing uses all RoHS-compliant components.

# Bill of Materials (BOM)

---

---

NOTES:



# MICROCHIP

## Worldwide Sales and Service

### AMERICAS

**Corporate Office**  
2355 West Chandler Blvd.  
Chandler, AZ 85224-6199  
Tel: 480-792-7200  
Fax: 480-792-7277  
Technical Support:  
<http://www.microchip.com/support>  
Web Address:  
[www.microchip.com](http://www.microchip.com)

**Atlanta**  
Duluth, GA  
Tel: 678-957-9614  
Fax: 678-957-1455

**Austin, TX**  
Tel: 512-257-3370

**Boston**  
Westborough, MA  
Tel: 774-760-0087  
Fax: 774-760-0088

**Chicago**  
Itasca, IL  
Tel: 630-285-0071  
Fax: 630-285-0075

**Cleveland**  
Independence, OH  
Tel: 216-447-0464  
Fax: 216-447-0643

**Dallas**  
Addison, TX  
Tel: 972-818-7423  
Fax: 972-818-2924

**Detroit**  
Novi, MI  
Tel: 248-848-4000

**Houston, TX**  
Tel: 281-894-5983

**Indianapolis**  
Noblesville, IN  
Tel: 317-773-8323  
Fax: 317-773-5453

**Los Angeles**  
Mission Viejo, CA  
Tel: 949-462-9523  
Fax: 949-462-9608

**New York, NY**  
Tel: 631-435-6000

**San Jose, CA**  
Tel: 408-735-9110

**Canada - Toronto**  
Tel: 905-673-0699  
Fax: 905-673-6509

### ASIA/PACIFIC

**Asia Pacific Office**  
Suites 3707-14, 37th Floor  
Tower 6, The Gateway  
Harbour City, Kowloon  
Hong Kong  
Tel: 852-2943-5100  
Fax: 852-2401-3431

**Australia - Sydney**  
Tel: 61-2-9868-6733  
Fax: 61-2-9868-6755

**China - Beijing**  
Tel: 86-10-8569-7000  
Fax: 86-10-8528-2104

**China - Chengdu**  
Tel: 86-28-8665-5511  
Fax: 86-28-8665-7889

**China - Chongqing**  
Tel: 86-23-8980-9588  
Fax: 86-23-8980-9500

**China - Dongguan**  
Tel: 86-769-8702-9880

**China - Hangzhou**  
Tel: 86-571-8792-8115  
Fax: 86-571-8792-8116

**China - Hong Kong SAR**  
Tel: 852-2943-5100  
Fax: 852-2401-3431

**China - Nanjing**  
Tel: 86-25-8473-2460  
Fax: 86-25-8473-2470

**China - Qingdao**  
Tel: 86-532-8502-7355  
Fax: 86-532-8502-7205

**China - Shanghai**  
Tel: 86-21-5407-5533  
Fax: 86-21-5407-5066

**China - Shenyang**  
Tel: 86-24-2334-2829  
Fax: 86-24-2334-2393

**China - Shenzhen**  
Tel: 86-755-8864-2200  
Fax: 86-755-8203-1760

**China - Wuhan**  
Tel: 86-27-5980-5300  
Fax: 86-27-5980-5118

**China - Xian**  
Tel: 86-29-8833-7252  
Fax: 86-29-8833-7256

### ASIA/PACIFIC

**China - Xiamen**  
Tel: 86-592-2388138  
Fax: 86-592-2388130

**China - Zhuhai**  
Tel: 86-756-3210040  
Fax: 86-756-3210049

**India - Bangalore**  
Tel: 91-80-3090-4444  
Fax: 91-80-3090-4123

**India - New Delhi**  
Tel: 91-11-4160-8631  
Fax: 91-11-4160-8632

**India - Pune**  
Tel: 91-20-3019-1500

**Japan - Osaka**  
Tel: 81-6-6152-7160  
Fax: 81-6-6152-9310

**Japan - Tokyo**  
Tel: 81-3-6880-3770  
Fax: 81-3-6880-3771

**Korea - Daegu**  
Tel: 82-53-744-4301  
Fax: 82-53-744-4302

**Korea - Seoul**  
Tel: 82-2-554-7200  
Fax: 82-2-558-5932 or  
82-2-558-5934

**Malaysia - Kuala Lumpur**  
Tel: 60-3-6201-9857  
Fax: 60-3-6201-9859

**Malaysia - Penang**  
Tel: 60-4-227-8870  
Fax: 60-4-227-4068

**Philippines - Manila**  
Tel: 63-2-634-9065  
Fax: 63-2-634-9069

**Singapore**  
Tel: 65-6334-8870  
Fax: 65-6334-8850

**Taiwan - Hsin Chu**  
Tel: 886-3-5778-366  
Fax: 886-3-5770-955

**Taiwan - Kaohsiung**  
Tel: 886-7-213-7828

**Taiwan - Taipei**  
Tel: 886-2-2508-8600  
Fax: 886-2-2508-0102

**Thailand - Bangkok**  
Tel: 66-2-694-1351  
Fax: 66-2-694-1350

### EUROPE

**Austria - Wels**  
Tel: 43-7242-2244-39  
Fax: 43-7242-2244-393

**Denmark - Copenhagen**  
Tel: 45-4450-2828  
Fax: 45-4485-2829

**France - Paris**  
Tel: 33-1-69-53-63-20  
Fax: 33-1-69-30-90-79

**Germany - Dusseldorf**  
Tel: 49-2129-3766400

**Germany - Munich**  
Tel: 49-89-627-144-0  
Fax: 49-89-627-144-44

**Germany - Pforzheim**  
Tel: 49-7231-424750

**Italy - Milan**  
Tel: 39-0331-742611  
Fax: 39-0331-466781

**Italy - Venice**  
Tel: 39-049-7625286

**Netherlands - Drunen**  
Tel: 31-416-690399  
Fax: 31-416-690340

**Poland - Warsaw**  
Tel: 48-22-3325737

**Spain - Madrid**  
Tel: 34-91-708-08-90  
Fax: 34-91-708-08-91

**Sweden - Stockholm**  
Tel: 46-8-5090-4654

**UK - Wokingham**  
Tel: 44-118-921-5800  
Fax: 44-118-921-5820

01/27/15

## Данный компонент на территории Российской Федерации

### Вы можете приобрести в компании MosChip.

Для оперативного оформления запроса Вам необходимо перейти по данной ссылке:

<http://moschip.ru/get-element>

Вы можете разместить у нас заказ для любого Вашего проекта, будь то серийное производство или разработка единичного прибора.

В нашем ассортименте представлены ведущие мировые производители активных и пассивных электронных компонентов.

Нашей специализацией является поставка электронной компонентной базы двойного назначения, продукции таких производителей как XILINX, Intel (ex.ALTERA), Vicor, Microchip, Texas Instruments, Analog Devices, Mini-Circuits, Amphenol, Glenair.

Сотрудничество с глобальными дистрибьюторами электронных компонентов, предоставляет возможность заказывать и получать с международных складов практически любой перечень компонентов в оптимальные для Вас сроки.

На всех этапах разработки и производства наши партнеры могут получить квалифицированную поддержку опытных инженеров.

Система менеджмента качества компании отвечает требованиям в соответствии с ГОСТ Р ИСО 9001, ГОСТ РВ 0015-002 и ЭС РД 009

### Офис по работе с юридическими лицами:

105318, г.Москва, ул.Щербаковская д.3, офис 1107, 1118, ДЦ «Щербаковский»

Телефон: +7 495 668-12-70 (многоканальный)

Факс: +7 495 668-12-70 (доб.304)

E-mail: [info@moschip.ru](mailto:info@moschip.ru)

Skype отдела продаж:

moschip.ru

moschip.ru\_4

moschip.ru\_6

moschip.ru\_9