

## Description

The 8P34S2102 is a high-performance, low-power, differential dual 1:2 LVDS output, 1.8V fanout buffer. The device is designed for the fanout of high-frequency, very low additive phase-noise clock and data signals.

Two independent buffer channels are available. Each channel has two low-skew outputs. High isolation between channels minimizes noise coupling. AC characteristics such as propagation delay are matched between channels. Guaranteed output-to-output and part-to-part skew characteristics make the 8P34S2102 ideal for those clock distribution applications demanding well-defined performance and repeatability.

The device is characterized to operate from a 1.8V power supply. The integrated bias voltage references enable easy interfacing of AC-coupled signals to the device inputs.

## Features

- Dual 1:2 low skew, low additive jitter LVDS fanout buffers
- Matched AC characteristics across both channels
- High isolation between channels
- Low power consumption
- Both differential CLKA, nCLKA and CLKB, nCLKB inputs accept LVDS, LVPECL and single-ended LVCMOS levels
- Maximum input clock frequency: 2GHz
- Output amplitudes: 350mV, 500mV (selectable)
- Output bank skew: 8ps typical
- Output skew: 10ps typical
- Low additive phase jitter, RMS: 45fs typical ( $f_{REF} = 156.25\text{MHz}$ , 12kHz - 20MHz)
- Full 1.8V supply voltage mode
- Device current consumption ( $I_{DD}$ ): 76mA typical
- Lead-free (RoHS 6), 16-lead VFQFN packaging
- -40°C to 85°C ambient operating temperature
- Supports case temperature up to 105°C

## Block Diagram

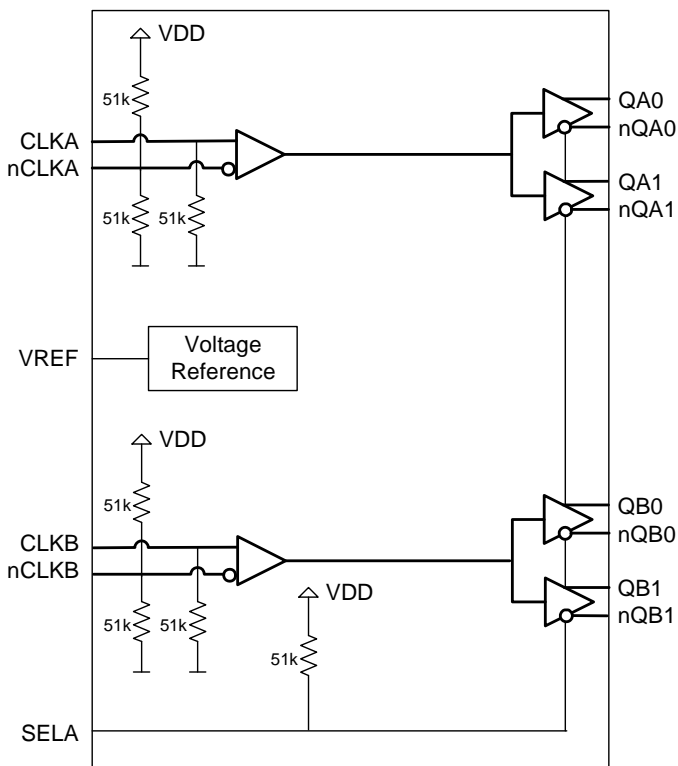

8P34S2102 transistor count: 293

## Pin Assignments

Figure 1. Pin Assignments for 3mm x 3mm VQFN Package – Top View

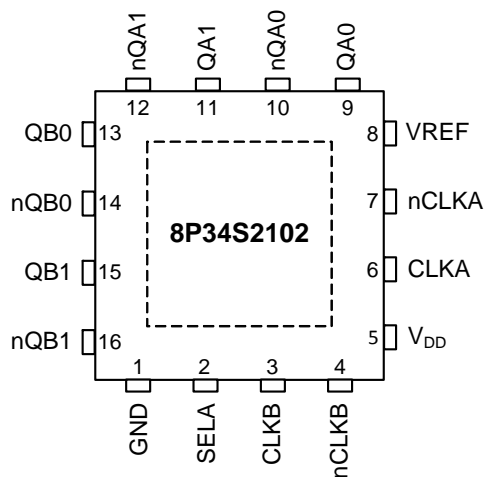

## Pin Descriptions

Table 1. Pin Descriptions

Number	Name	Type <sup>[a]</sup>	Description
1	GND	Power	Power supply ground.
2	SELA	Input (PU)	Control input. Output amplitude select.
3	CLKB	Input (PD)	Non-inverting differential clock/data input for channel B.
4	nCLKB	Input (PD/PU)	Inverting differential clock/data input for channel B.
5	V <sub>DD</sub>	Power	Power supply pin.
6	CLKA	Input (PD)	Non-inverting differential clock/data input for channel A.
7	nCLKA	Input (PD/PU)	Inverting differential clock/data input for channel A.
8	VREF	Output	Bias voltage reference for CLKA, nCLKA and CLKB, nCLKB input pairs.
9	QA0	Output	Differential output A0. LVDS interface levels.
10	nQA0	Output	Differential output A0. LVDS interface levels.
11	QA1	Output	Differential output A1. LVDS interface levels.
12	nQA1	Output	Differential output A1. LVDS interface levels.
13	QB0	Output	Differential output B0. LVDS interface levels.
14	nQB0	Output	Differential output B0. LVDS interface levels.
15	QB1	Output	Differential output B1. LVDS interface levels.
16	nQB1	Output	Differential output B1. LVDS interface levels.
ePad	GND_EPAD	Power	Exposed pad of package. Connect to ground.

[a] Pull-up (PU) and pull-down (PD) resistors are indicated in parentheses. *Pull-up* and *pull-down* refers to internal input resistors. See [Table 4, DC Input Characteristics](#), for typical values.

## Function Tables

Table 2. SELA Output Amplitude Selection Table

SELA	QA, QB Output Amplitude (mV)
0	350
1 (default)	500

## Absolute Maximum Ratings

The absolute maximum ratings are stress ratings only. Stresses greater than those listed below can cause permanent damage to the device. Functional operation of the 8P34S2102 at absolute maximum ratings is not implied. Exposure to absolute maximum rating conditions may affect device reliability.

Table 3. Absolute Maximum Ratings

Item	Rating
Supply voltage, $V_{DD}$	4.6V
Inputs, $V_I$	-0.5V to $V_{DD} + 0.5V$
Outputs, $I_O$ Continuous current Surge current	10mA 15mA
Input sink/source, $I_{REF}$	$\pm 2mA$
Maximum Junction Temperature, $T_{J,MAX}$	125°C
Storage Temperature, $T_{STG}$	-65°C to 150°C
ESD - Human Body Model <sup>[a]</sup>	2000V
ESD - Charged Device Model <sup>[a]</sup>	1500V

[a] According to JEDEC JS-001-2012/JESD22-C101E.

## DC Electrical Characteristics

Table 4. DC Input Characteristics

Symbol	Parameter	Test Conditions	Minimum	Typical	Maximum	Units
$C_{IN}$	Input capacitance			2		pF
$R_{PULLDOWN}$	Input pull-down resistor			51		k $\Omega$
$R_{PULLUP}$	Input pull-up resistor			51		k $\Omega$

Table 5. Power Supply DC Characteristics,  $V_{DD} = 1.8V \pm 5\%$ ,  $T_A = -40^\circ\text{C}$  to  $85^\circ\text{C}$ 

Symbol	Parameter		Test Conditions	Minimum	Typical	Maximum	Units
$V_{DD}$	Power supply voltage			1.71	1.8	1.89	V
$I_{DD}$	Power supply current	QA[0:1], QB[0:1] outputs terminated $100\Omega$ between nQx, Qx	500mV amplitude		93	120	mA
			350mV amplitude		76	96	mA

 Table 6. LVCMOS Inputs DC Characteristics,  $V_{DD} = 1.8V \pm 5\%$ ,  $T_A = -40^\circ\text{C}$  to  $85^\circ\text{C}$ 

Symbol	Parameter		Test Conditions	Minimum	Typical	Maximum	Units
$V_{IH}$	Input high voltage	SELA		$0.65 \cdot V_{DD}$		$V_{DD} + 0.3$	V
$V_{IL}$	Input low voltage	SELA		-0.3		$0.35 \cdot V_{DD}$	V
$I_{IH}$	Input high current	SELA	$V_{IN} = V_{DD} = 1.89V$			10	$\mu\text{A}$
$I_{IL}$	Input low current	SELA	$V_{IN} = 0V, V_{DD} = 1.89V$	-150			$\mu\text{A}$

 Table 7. Differential Inputs Characteristics,  $V_{DD} = 1.8V \pm 5\%$ ,  $T_A = -40^\circ\text{C}$  to  $85^\circ\text{C}$ 

Symbol	Parameter		Test Conditions	Minimum	Typical	Maximum	Units
$I_{IH}$	Input high current	CLKA, nCLKA CLKB, nCLKB	$V_{IN} = V_{DD} = 1.89V$			150	$\mu\text{A}$
$I_{IL}$	Input low current	CLKA, CLKB	$V_{IN} = 0V, V_{DD} = 1.89V$	-10			$\mu\text{A}$
		nCLKA, nCLKB	$V_{IN} = 0V, V_{DD} = 1.89V$	-150			$\mu\text{A}$
VREF	Reference voltage <sup>[a]</sup>		$I_{REF} = +100\mu\text{A}, V_{DD} = 1.8V$	0.9		1.30	V

[a] VREF specification is applicable to the AC-coupled input interfaces shown in [Figure 5](#) and [Figure 6](#).

 Table 8. LVDS DC Characteristics,  $V_{DD} = 1.8V \pm 5\%$ ,  $T_A = -40^\circ\text{C}$  to  $85^\circ\text{C}$ 

Symbol	Parameter	Test Conditions	Minimum	Typical	Maximum	Units
$\Delta V_{OD}$	$V_{OD}$ Magnitude Change				50	mV
$\Delta V_{OS}$	$V_{OS}$ Magnitude Change				50	mV

## AC Electrical Characteristics

 Table 9. AC Electrical Characteristics,  $V_{DD} = 1.8V \pm 5\%$ ,  $T_A = -40^{\circ}C$  to  $85^{\circ}C$  [a]

Symbol	Parameter	Test Conditions	Minimum	Typical	Maximum	Units
$f_{REF}$	Input frequency				2	GHz
$\Delta V/\Delta t$	Input edge rate		1.5			V/ns
$t_{PD}$	Propagation delay <sup>[b], [c]</sup>	CLKA to any QAx, CLKB to any nQBx	100	225	400	ps
/sk(o)	Output skew <sup>[d], [e]</sup>			10	30	ps
/sk(b)	Output bank skew <sup>[e], [f]</sup>			8	25	ps
/sk(p)	Pulse skew <sup>[g]</sup>	$f_{REF} = 100MHz$		5	20	ps
/sk(pp)	Part-to-part skew <sup>[e], [h]</sup>				200	ps
$t_{JIT}$	Buffer Additive Phase Jitter, RMS; 500mV amplitude; refer to <a href="#">Additive Phase Jitter</a>	$f_{REF} = 156.25MHz$ ; Integration range: 1kHz – 40MHz		60	75	fs
		$f_{REF} = 156.25MHz$ square wave, $V_{PP} = 1V$ ; Integration range: 12kHz – 20MHz		45	55	fs
$\Phi_N(\geq 30M)$	Clock single-side band phase noise	$\geq 30MHz$ offset from carrier and noise floor		< -160		dBc/Hz
$t_{JIT, SP}$	Spurious suppression, coupling between channels	$f_{QA} = 491.52MHz$ , $f_{QB} = 61.44MHz$ ; measured between neighboring outputs		-71		dB
		$f_{QA} = 491.52MHz$ , $f_{QB} = 15.36MHz$ ; measured between neighboring outputs		-82		dB
$t_R / t_F$	Output rise/ fall time	10% to 90%, outputs loaded with $100\Omega$		220	400	ps
		20% to 80%, outputs loaded with $100\Omega$		110	250	ps
$V_{PP}$	Input voltage amplitude	CLKA, CLKB	0.15		1.2	V
$V_{PP\_DIFF}$	Differential input voltage amplitude	CLKA, CLKB	0.3		2.4	V
$V_{CMR}$	Common mode input voltage <sup>[i]</sup>		1.1		$V_{DD} - (V_{PP}/2)$	V
$V_{OD}$	Differential output voltage	SELA = 0, outputs loaded with $100\Omega$	247	350	454	mV
		SELA = 1, outputs loaded with $100\Omega$	300	500	650	mV
$V_{OS}$	Offset voltage	SELA = 0		0.77		V
		SELA = 1		0.68		V

[a] Electrical parameters are guaranteed over the specified ambient operating temperature range, which is established when the device is mounted in a test socket with maintained transverse airflow greater than 500 lpm. The device will meet specifications after thermal equilibrium has been reached under these conditions.

[b] Measured from the differential input crossing point to the differential output crossing point.

[c] Input  $V_{PP} = 400mV$ .

- [d] Defined as skew between outputs at the same supply voltage and with equal load conditions. Measured at the differential cross points.
- [e] This parameter is defined in accordance with JEDEC Standard 65.
- [f] Defined as skew within a bank of outputs at the same voltage and with equal load conditions.
- [g] Output pulse skew is the absolute value of the difference of the propagation delay times:  $|t_{PLH} - t_{PHL}|$ .
- [h] Defined as skew between outputs on different devices operating at the same supply voltage, same frequency, same temperature and with equal load conditions. Using the same type of inputs on each device, the outputs are measured at the differential cross points.
- [i] Common Mode Input Voltage is defined as the cross-point voltage.

## Additive Phase Jitter

The spectral purity in a band at a specific offset from the fundamental compared to the power of the fundamental is called the *dBc Phase Noise*. This value is normally expressed using a Phase noise plot and is most often the specified plot in many applications. Phase noise is defined as the ratio of the noise power present in a 1Hz band at a specified offset from the fundamental frequency to the power value of the fundamental. This ratio is expressed in decibels (dBm) or a ratio of the power in the 1Hz band to the power in the fundamental. When the required offset is specified, the phase noise is called a *dBc* value, which simply means dBm at a specified offset from the fundamental. By investigating jitter in the frequency domain, we get a better understanding of its effects on the desired application over the entire time record of the signal. It is mathematically possible to calculate an expected bit error rate given a phase noise plot.

Figure 2. Additive Phase Jitter. Frequency: 156.25MHz, Integration range: 12kHz to 20MHz = 45fs typical

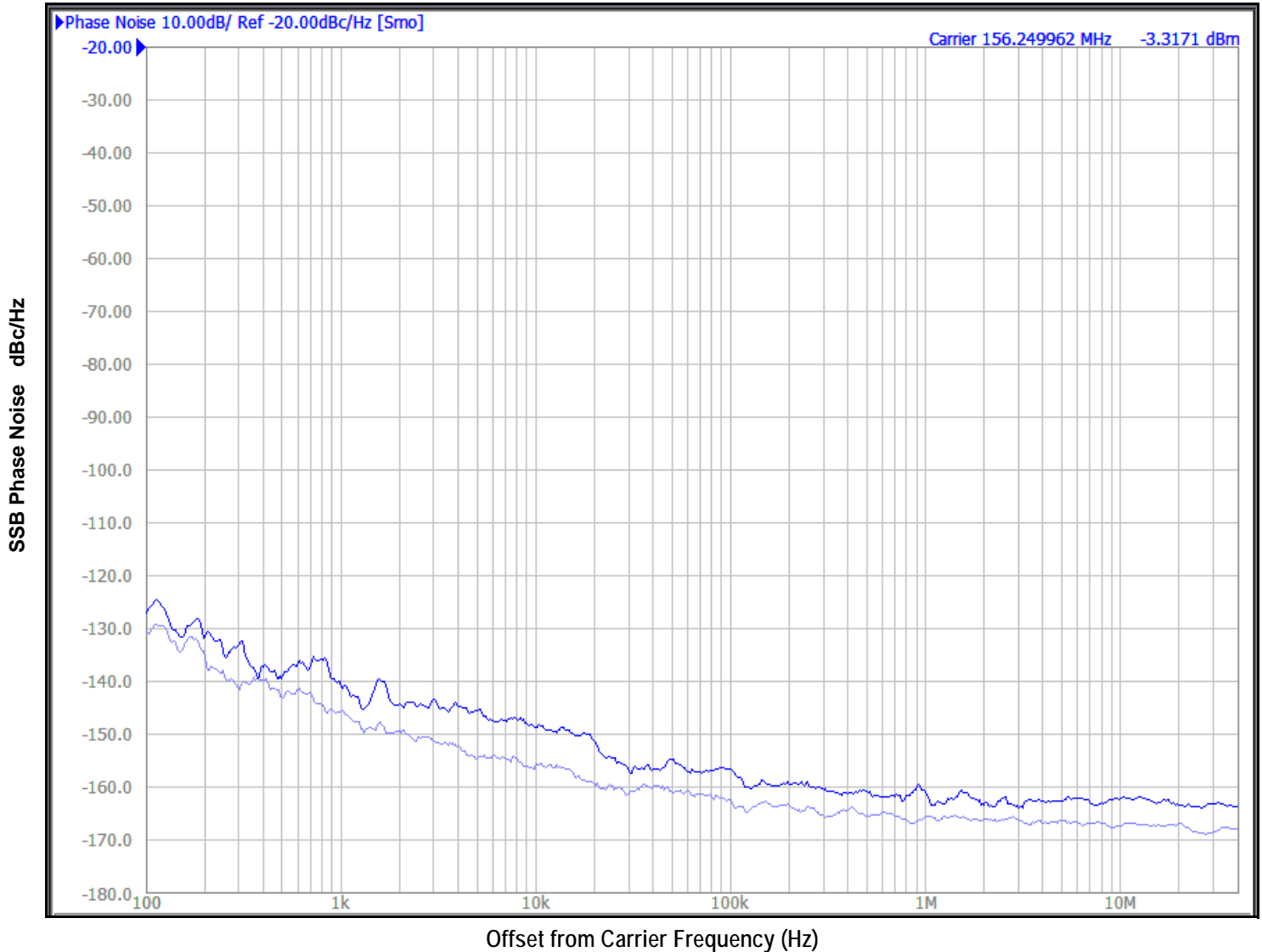

As with most timing specifications, phase noise measurements have issues relating to the limitations of the measurement equipment. The noise floor of the equipment can be higher or lower than the noise floor of the device. Additive phase noise is dependent on both the noise floor of the input source and measurement equipment.

Measured using a Wenzel 156.25MHz Oscillator as the input source.

## Applications Information

### Recommendations for Unused Input and Output Pins

#### Inputs

##### **CLK/nCLK Inputs**

For applications not requiring the use of the differential input, both CLK and nCLK can be left floating. Though not required, but for additional protection, a 1kΩ resistor can be tied from CLK to ground.

#### Outputs

##### **LVDS Outputs**

All unused LVDS output pairs can be either left floating or terminated with 100Ω across. If they are left floating there should be no trace attached.

##### **VREF**

The unused VREF pin can be left floating. We recommend that there is no trace attached.

### Wiring the Differential Input to Accept Single-Ended Levels

Figure 3 shows how a differential input can be wired to accept single ended levels. The reference voltage  $V_1 = V_{DD}/2$  is generated by the bias resistors R1 and R2. The bypass capacitor (C1) is used to help filter noise on the DC bias. This bias circuit should be located as close to the input pin as possible. The ratio of R1 and R2 might need to be adjusted to position the  $V_1$  in the center of the input voltage swing. For example, if the input clock swing is 1.8V and  $V_{DD} = 1.8V$ , R1 and R2 value should be adjusted to set  $V_1$  at 0.9V. The values below are for when both the single ended swing and  $V_{DD}$  are at the same voltage. This configuration requires that the sum of the output impedance of the driver ( $R_o$ ) and the series resistance ( $R_s$ ) equals the transmission line impedance. In addition, matched termination at the input will attenuate the signal in half. This can be done in one of two ways. First, R3 and R4 in parallel should equal the transmission line impedance. For most 50Ω applications, R3 and R4 can be 100Ω. The values of the resistors can be increased to reduce the loading for slower and weaker LVCMOS driver.

When using single-ended signaling, the noise rejection benefits of differential signaling are reduced. Even though the differential input can handle full rail LVCMOS signaling, it is recommended that the amplitude be reduced while maintaining an edge rate faster than 1V/ns. The datasheet specifies a lower differential amplitude, however this only applies to differential signals. For single-ended applications, the swing can be larger, however  $V_{IL}$  cannot be less than -0.3V and  $V_{IH}$  cannot be more than  $V_{DD} + 0.3V$ . Though some of the recommended components might not be used, the pads should be placed in the layout. They can be utilized for debugging purposes. The datasheet specifications are characterized and guaranteed by using a differential signal.

Figure 3. Recommended Schematic for Wiring a Differential Input to Accept Single-ended Levels

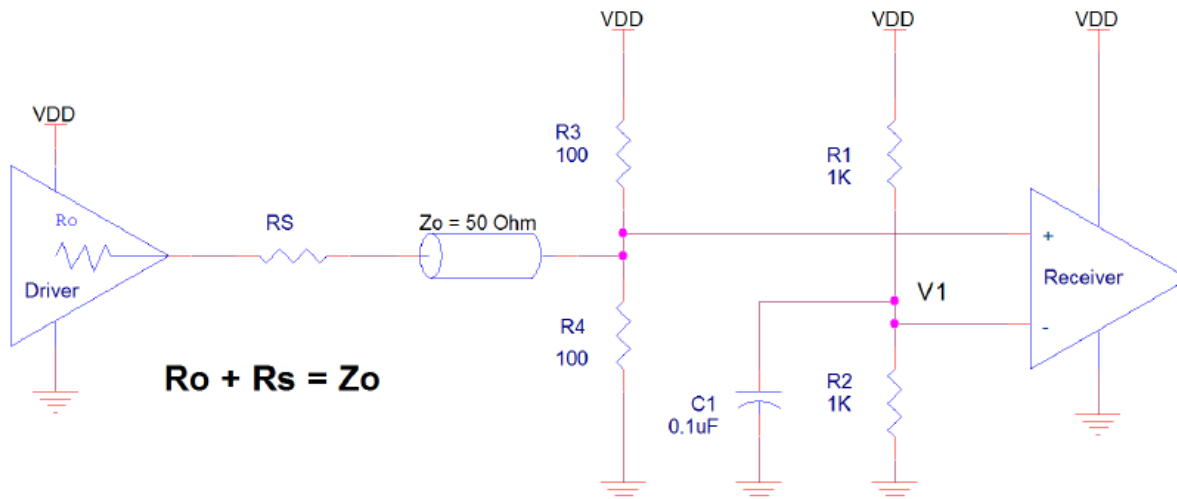



## 1.8V Differential Clock Input Interface

The CLK /nCLK accepts LVDS, LVPECL and other differential signals. The differential input signal must meet both the  $V_{PP}$  and  $V_{CMR}$  input requirements. *Figure 4 to Figure 6* show interface examples for the CLK /nCLK input driven by the most common driver types. The input interfaces suggested here are examples only. If the driver is from another vendor, use their termination recommendation. Please consult with the vendor of the driver component to confirm the driver termination requirements.

Figure 4. Differential Input Driven by an LVDS Driver - DC Coupling

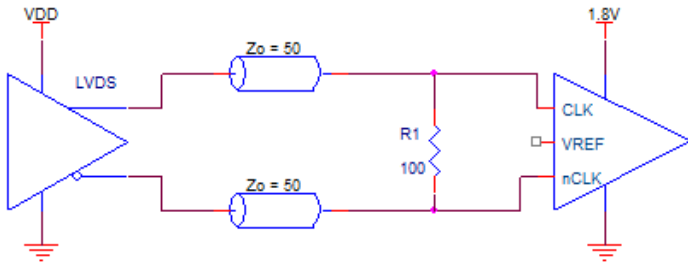

Figure 5. Differential Input Driven by an LVDS Driver - AC Coupling

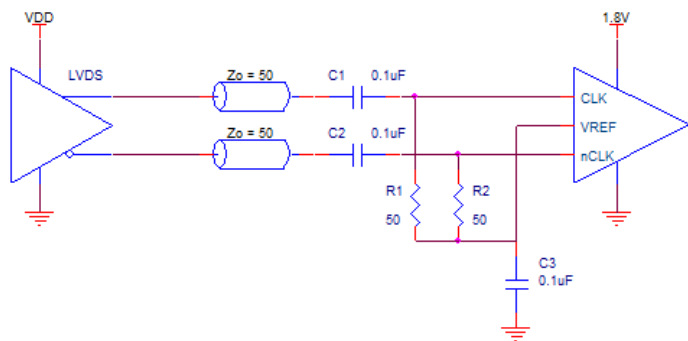
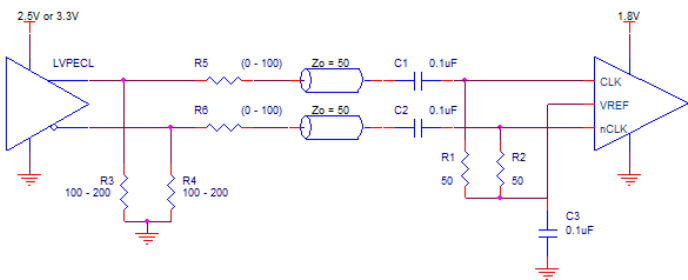

Figure 6. Differential Input Driven by an LVPECL Driver - AC Coupling



## LVDS Driver Termination

For a general LVDS interface, the recommended value for the termination impedance ( $Z_T$ ) is between  $90\Omega$  and  $132\Omega$ . The actual value should be selected to match the differential impedance ( $Z_0$ ) of your transmission line. A typical point-to-point LVDS design uses a  $100\Omega$  parallel resistor at the receiver and a  $100\Omega$  differential transmission-line environment. In order to avoid any transmission-line reflection issues, the components should be surface mounted and must be placed as close to the receiver as possible. IDT offers a full line of LVDS compliant devices with two types of output structures: current source and voltage source.

The standard termination schematic as shown in [Figure 7](#) can be used with either type of output structure. [Figure 8](#), which can also be used with both output types, is an optional termination with center tap capacitance to help filter common mode noise. The capacitor value should be approximately  $50\text{pF}$ . If using a non-standard termination, it is recommended to contact IDT and confirm if the output structure is current source or voltage source type. In addition, since these outputs are LVDS compatible, the input receiver's amplitude and common-mode input range should be verified for compatibility with the output.

Figure 7. Standard LVDS Termination

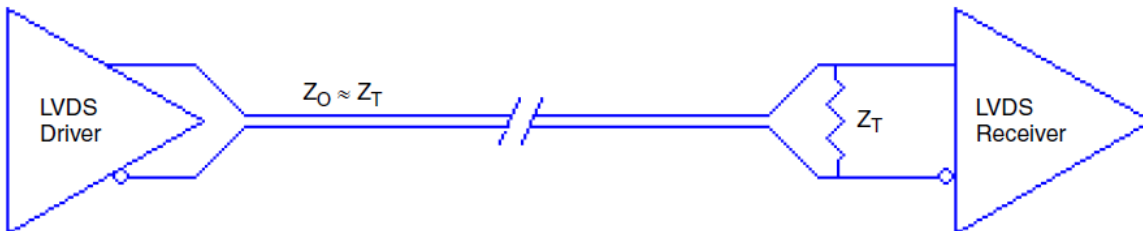
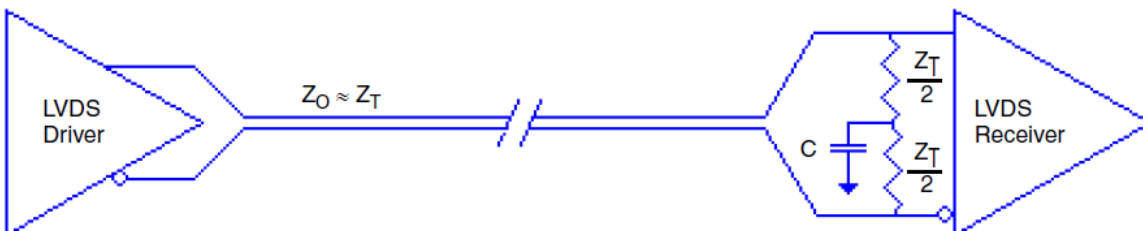

Figure 8. Optional LVDS Termination



## VFQFN EPAD Thermal Release Path

In order to maximize both the removal of heat from the package and the electrical performance, a land pattern must be incorporated on the Printed Circuit Board (PCB) within the footprint of the package corresponding to the exposed metal pad or exposed heat slug on the package, as shown in [Figure 9](#). The solderable area on the PCB, as defined by the solder mask, should be at least the same size/shape as the exposed pad/slug area on the package to maximize the thermal/electrical performance. Sufficient clearance should be designed on the PCB between the outer edges of the land pattern and the inner edges of pad pattern for the leads to avoid any shorts.

While the land pattern on the PCB provides a means of heat transfer and electrical grounding from the package to the board through a solder joint, thermal vias are necessary to effectively conduct from the surface of the PCB to the ground plane(s). The land pattern must be connected to ground through these vias. The vias act as “heat pipes”. The number of vias (i.e. “heat pipes”) are application specific and dependent upon the package power dissipation as well as electrical conductivity requirements. Thus, thermal and electrical analysis and/or testing are recommended to determine the minimum number needed. Maximum thermal and electrical performance is achieved when an array of vias is incorporated in the land pattern. It is recommended to use as many vias connected to ground as possible. It is also recommended that the via diameter should be 12 to 13mils (0.30 to 0.33mm) with 1oz copper via barrel plating. This is desirable to avoid any solder wicking inside the via during the soldering process which may result in voids in solder between the exposed pad/slug and the thermal land. Precautions should be taken to eliminate any solder voids between the exposed heat slug and the land pattern. Note: These recommendations are to be used as a guideline only.

For more information, refer to the application note on the *Surface Mount Assembly of Amkor’s Thermally/ Electrically Enhance Leadframe Base Package*, Amkor Technology.

Figure 9. P.C. Assembly for Exposed Pad Thermal Release Path – Side View (drawing not to scale)

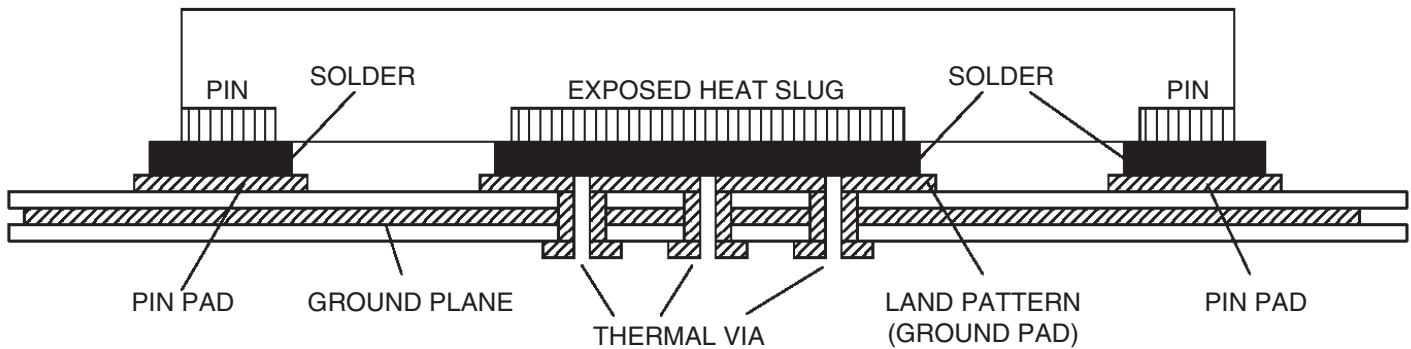

## Case Temperature Considerations

This device supports applications in a natural convection environment which does not have any thermal conductivity through ambient air. The printed circuit board (PCB) is typically in a sealed enclosure without any natural or forced air flow and is kept at or below a specific temperature. The device package design incorporates an exposed pad (ePad) with enhanced thermal parameters which is soldered to the PCB where most of the heat escapes from the bottom exposed pad. For this type of application, it is recommended to use the junction-to-board thermal characterization parameter  $\Psi_{JB}$  (Psi-JB) to calculate the junction temperature ( $T_J$ ) and ensure it does not exceed the maximum allowed junction temperature in the Absolute Maximum Rating table.

The junction-to-board thermal characterization parameter,  $\Psi_{JB}$ , is calculated using the following equation:

$$T_J = T_{CB} + \Psi_{JB} \times P_D, \text{ where}$$

$T_J$  = Junction temperature at steady state condition in ( $^{\circ}\text{C}$ ).

$T_{CB}$  = Case temperature (Bottom) at steady state condition in ( $^{\circ}\text{C}$ ).

$\Psi_{JB}$  = Thermal characterization parameter to report the difference between junction temperature and the temperature of the board measured at the top surface of the board.

$P_D$  = power dissipation (W) in desired operating configuration.

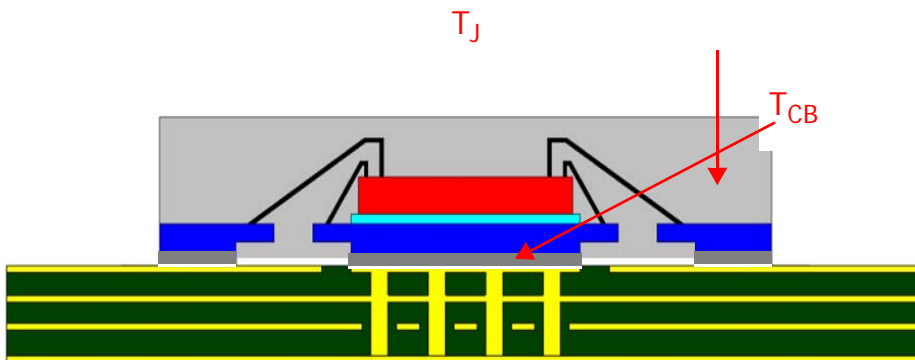

The ePad provides a low thermal resistance path for heat transfer to the PCB and represents the key pathway to transfer heat away from the IC to the PCB. It's critical that the connection of the exposed pad to the PCB is properly constructed to maintain the desired IC case temperature ( $T_{CB}$ ). A good connection ensures that temperature at the exposed pad ( $T_{CB}$ ) and the board temperature ( $T_B$ ) are relatively the same. An improper connection can lead to increased junction temperature, increased power consumption and decreased electrical performance. In addition, there could be long-term reliability issues and increased failure rate.

Example Calculation for Junction Temperature ( $T_J$ ):  $T_J = T_{CB} + \Psi_{JB} \times P_D$

Package type	16 VFQFN
Body size (mm)	3 x 3 x 0.9
ePad size (mm)	1.7 x 1.7
Thermal Via	2 x 2 Matrix
$\Psi_{JB}$	1.3 $^{\circ}\text{C}/\text{W}$
$T_{CB}$	105 $^{\circ}\text{C}$
$P_D$	0.21W

For the variables above, the junction temperature is equal to 105.3 $^{\circ}\text{C}$ . Since this is below the maximum junction temperature of 125 $^{\circ}\text{C}$ , there are no long term reliability concerns. In addition, since the junction temperature at which the device was characterized using forced convection is 119 $^{\circ}\text{C}$ , this device can function without the degradation of the specified AC or DC parameters.

## Power Considerations

This section provides information on power dissipation and junction temperature for the 8P34S2102. Equations and example calculations are also provided.

### 1. Power Dissipation.

The following is the power dissipation for  $V_{DD} = 1.8V + 5\% = 1.89V$ , which gives worst case results.

Maximum current at 85°C:  $V_{DD\_MAX} = 112mA$ .

- $Power\_MAX = V_{DD\_MAX} * I_{DD\_MAX} = 1.89V * 112mA = 211.68mW$

### 2. Junction Temperature.

Junction temperature,  $T_j$ , is the temperature at the junction of the bond wire and bond pad directly affects the reliability of the device. The maximum recommended junction temperature is 125°C. Limiting the internal transistor junction temperature,  $T_j$ , to 125°C ensures that the bond wire and bond pad temperature remains below 125°C.

The equation for  $T_j$  is as follows:  $T_j = \theta_{JA} * Pd\_total + T_A$

$T_j$  = Junction Temperature

$\theta_{JA}$  = Junction-to-Ambient Thermal Resistance

$Pd\_total$  = Total Device Power Dissipation (example calculation is in section 1 above)

$T_A$  = Ambient Temperature

In order to calculate junction temperature, the appropriate junction-to-ambient thermal resistance  $\theta_{JA}$  must be used. Assuming no air flow and a multi-layer board, the appropriate value is 74.7°C/W per [Table 10](#) below.

Therefore,  $T_j$  for an ambient temperature of 85°C with all outputs switching is:

$$85^\circ C + 0.21168W * 74.7^\circ C/W = 100.8^\circ C. \text{ This is below the limit of } 125^\circ C.$$

This calculation is only an example.  $T_j$  will obviously vary depending on the number of loaded outputs, supply voltage, air flow and the type of board (multi-layer).

Table 10. Thermal Resistance  $\theta_{JA}$  for 16-lead VFQFN, Forced Convection

$\theta_{JA}$ (°C/W) vs. Air Flow (m/s)			
Meters per Second	0	1	2
16-lead VFQFN Multi-Layer PCB, JEDEC Standard Test Boards	74.7	65.3	58.5

## Package Outline Drawings

The package outline drawings are located in the last section of this document. The package information is the most current data available and is subject to change without notice or revision of this document.

## Marking Diagram

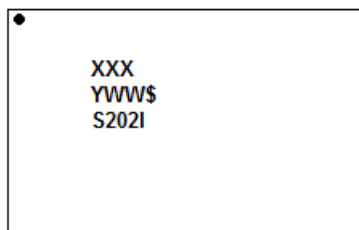

1. "XXX" indicates the last three characters of the Asm lot number.
2. Line 2:
  - "YVWWS" indicates the date code (Y is the last digit of the year, and "VWWS" is a work week number that the part was assembled).
  - "\$": mark code.
3. Line 3 indicates the truncated part number.

## Ordering Information

Table 11. Ordering Information

Part/Order Number	Marking	Package	Shipping Packaging	Temperature
8P34S2102NLGI	S202I	16-lead VFQFN, Lead-Free	Tray	-40°C to 85°C
8P34S2102NLGI8	S202I		Tape & Reel, Pin 1 Orientation: EIA-481-C	
8P34S2102NLGI/W	S202I		Tape & Reel, Pin 1 Orientation: EIA-481-D/E	

Table 12. Pin 1 Orientation in Tape and Reel Packaging

Part Number Suffix	Pin 1 Orientation	Illustration
8	Quadrant 1 (EIA-481-C)	
/W	Quadrant 2 (EIA-481-D/E)	

## Revision History

Revision Date	Description of Change
September 21, 2017	<ul style="list-style-type: none"> <li>▪ Updated the package outline drawings; however, no mechanical changes</li> <li>▪ Completed other minor improvements</li> </ul>
October 20, 2016	Initial datasheet.



Corporate Headquarters  
 6024 Silver Creek Valley Road  
 San Jose, CA 95138 USA  
[www.IDT.com](http://www.IDT.com)

Sales  
 1-800-345-7015 or 408-284-8200  
 Fax: 408-284-2775  
[www.IDT.com/go/sales](http://www.IDT.com/go/sales)

Tech Support  
[www.IDT.com/go/support](http://www.IDT.com/go/support)

DISCLAIMER Integrated Device Technology, Inc. (IDT) and its affiliated companies (herein referred to as "IDT") reserve the right to modify the products and/or specifications described herein at any time, without notice, at IDT's sole discretion. Performance specifications and operating parameters of the described products are determined in an independent state and are not guaranteed to perform the same way when installed in customer products. The information contained herein is provided without representation or warranty of any kind, whether express or implied, including, but not limited to, the suitability of IDT's products for any particular purpose, an implied warranty of merchantability, or non-infringement of the intellectual property rights of others. This document is presented only as a guide and does not convey any license under intellectual property rights of IDT or any third parties.

IDT's products are not intended for use in applications involving extreme environmental conditions or in life support systems or similar devices where the failure or malfunction of an IDT product can be reasonably expected to significantly affect the health or safety of users. Anyone using an IDT product in such a manner does so at their own risk, absent an express, written agreement by IDT.

Integrated Device Technology, IDT and the IDT logo are trademarks or registered trademarks of IDT and its subsidiaries in the United States and other countries. Other trademarks used herein are the property of IDT or their respective third party owners. For datasheet type definitions and a glossary of common terms, visit [www.idt.com/go/glossary](http://www.idt.com/go/glossary). Integrated Device Technology, Inc.. All rights reserved.

# 16L-QFN Package Outline Drawing

3.0 x 3.0 x 1.0 mm, 0.5 mm Pitch, 1.70 x 1.70 mm Epad  
 NL/NLG16P2, PSC-4169-02, Rev 03, Page 1

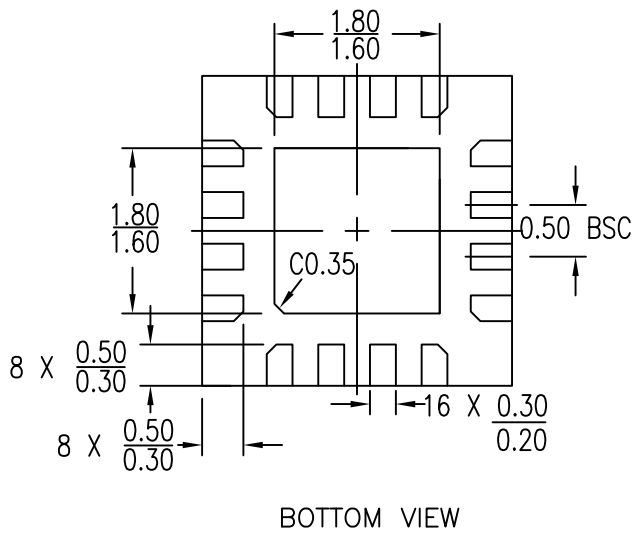
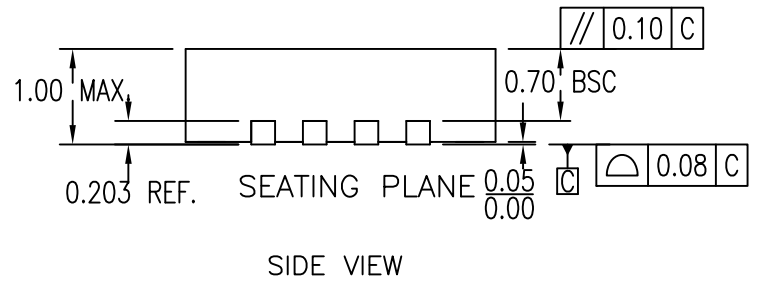
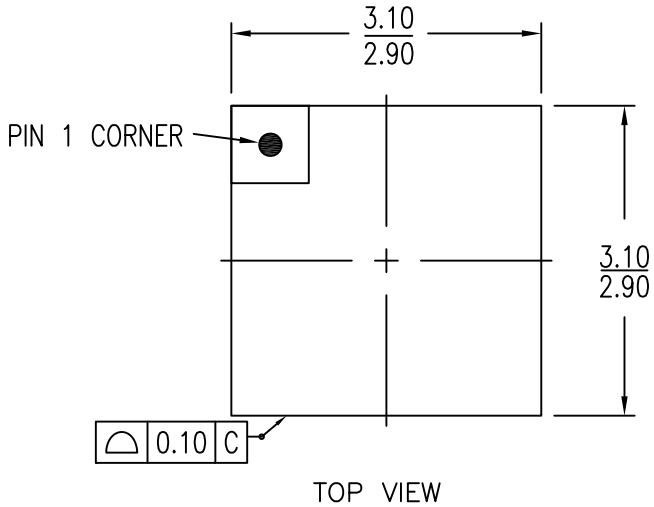

NOTES:

1. ALL DIMENSIONS ARE IN mm. ANGLES IN DEGREES



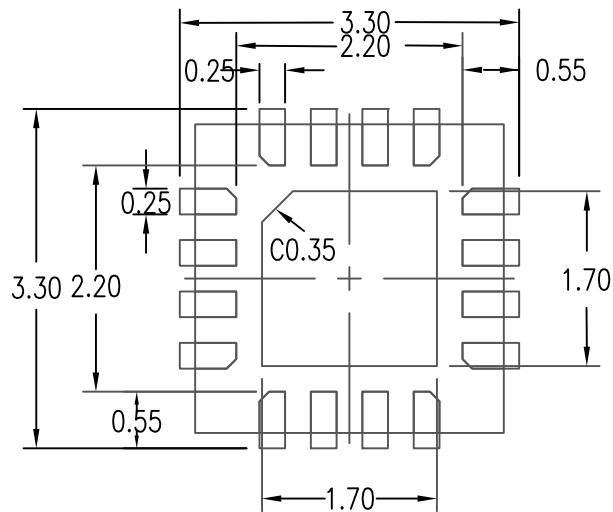

RECOMMENDED LAND PATTERN

NOTES:

1. ALL DIMENSIONS ARE IN mm.ANGLES IN DEGREES
2. TOP DOWN VIEW-AS VIEWED ON PCB
3. LAND PATTERN RECOMMENDATION IS PER IPC-7351B GENERIC REQUIREMENT FOR SURFACE MOUNT DESIGN AND LAND PATTERN

Package Revision History		
Date Created	Rev No.	Description
Aug 15, 2017	Rev 03	Update Epad Range
Jul 28, 2017	Rev 02	New format

## Данный компонент на территории Российской Федерации

### Вы можете приобрести в компании MosChip.

Для оперативного оформления запроса Вам необходимо перейти по данной ссылке:

<http://moschip.ru/get-element>

Вы можете разместить у нас заказ для любого Вашего проекта, будь то серийное производство или разработка единичного прибора.

В нашем ассортименте представлены ведущие мировые производители активных и пассивных электронных компонентов.

Нашей специализацией является поставка электронной компонентной базы двойного назначения, продукции таких производителей как XILINX, Intel (ex.ALTERA), Vicor, Microchip, Texas Instruments, Analog Devices, Mini-Circuits, Amphenol, Glenair.

Сотрудничество с глобальными дистрибьюторами электронных компонентов, предоставляет возможность заказывать и получать с международных складов практически любой перечень компонентов в оптимальные для Вас сроки.

На всех этапах разработки и производства наши партнеры могут получить квалифицированную поддержку опытных инженеров.

Система менеджмента качества компании отвечает требованиям в соответствии с ГОСТ Р ИСО 9001, ГОСТ РВ 0015-002 и ЭС РД 009

### Офис по работе с юридическими лицами:

105318, г.Москва, ул.Щербаковская д.3, офис 1107, 1118, ДЦ «Щербаковский»

Телефон: +7 495 668-12-70 (многоканальный)

Факс: +7 495 668-12-70 (доб.304)

E-mail: [info@moschip.ru](mailto:info@moschip.ru)

Skype отдела продаж:

moschip.ru

moschip.ru\_4

moschip.ru\_6

moschip.ru\_9