

# PLC INTERFACE With Leakage Current and Interference Voltage Suppression

## PLC-...SO46

---

### 1. Description

PLC INTERFACE, the super thin, plug-in, and flexible modular interface system with a user-friendly jumper system, now offers an extended range of relay interfaces for applications in which high levels of interference voltage occur on the control side (coil).

#### Application Problem: Long Cables

This problem is familiar to almost every practical expert: relays do not drop again on a "0" signal or even pick up in extreme cases due to interference voltages on the control cables. This is often caused by long and/or poorly-laid cables. AC voltages are thus coupled from neighboring cables, which frequently exceed 10 V. Conventional coupling relays become overloaded with these undefined signals and do not demonstrate clear switching behavior.

#### Application Problem: Leakage Currents From AC Outputs

The same effect occurs if electronic AC outputs produce leakage currents. This is often the case for many AC voltage initiators and PLC AC output cards. Leakage currents of several mA can also adversely affect the operation of conventional relays, which remain "suspended".

#### Solution: PLC-...SO46 With Integrated Filter

6.2 mm (0.244 in.) and 14 mm (0.551 in.) PLC-...SO46 versions with integrated filter are now available for applications in 120 V AC or 230 V AC networks with high levels of interference voltage. This multi-level filter circuit considerably reduces interference in the control circuit and thus contributes to safe signal transmission.

The PLC-...SO46 is only supplied as a basic terminal block with filter; a relay or optocoupler is not fitted. For possible components, please refer to the Technical Data.



#### All Other PLC Advantages

The PLC-...SO46 series also features the other advantages of the PLC range:

- Super thin 6.2 mm (0.244 in.) and 14 mm (0.551 in.) design
- Either universal SPDT or sensor version for input signals
- User-friendly, vibration-resistant, and time-saving jumper system
- Integrated input and protection circuit
- Relay or optocoupler can be quickly replaced using an engagement lever
- Either screw or spring-cage connection technology
- ...

## 2. Technical Data: Universal Range

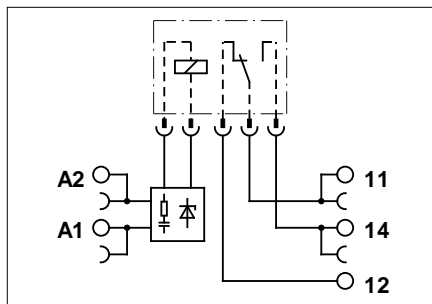

Circuit diagram

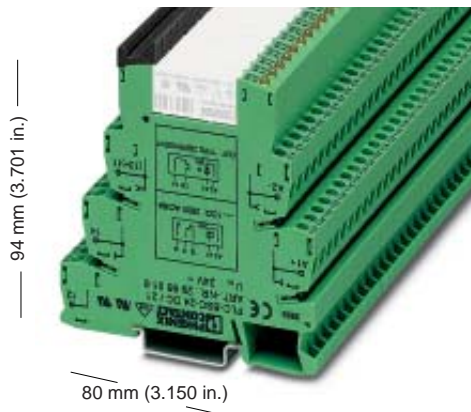

### PLC-B.../21/SO46

Basic terminal block with integrated filter that can be fitted with a relay or optocoupler

Housing width 6.2 mm (0.244 in.) (UL cULus provided)

<sup>1)</sup>The technical data only applies to basic terminal blocks fitted with a REL-MR-60DC/21 or REL-MR-60DC/21AU

**Note:** Please refer to the INTERFACE catalog for assembly instructions and accessories



M 3



	solid	flexible	AWG	I [A]	U [V]
Connection data	0.14 - 2.5	0.14 - 2.5	26 - 14	*	*

\* The electrical data is determined by the relay.

Description	Input voltage U <sub>N</sub>
<b>PLC interface with screw connection</b> PLC-BSC.../21/SO46 basic terminal block for plug-in REL-MR-60DC... miniature relay, for mounting on	120 V AC 230 V AC
<b>PLC interface with spring-cage connection</b> PLC-BSP.../21/SO46 basic terminal block for plug-in REL-MR-60DC... miniature relay, for mounting on	120 V AC 230 V AC
<b>Suitable plug-in miniature relay</b>	Gold contact Power contact

Type	Order No.	Pcs. Pkt.
<b>PLC-BSC-120UC/21/SO46</b>	29 80 31 9	10
<b>PLC-BSC-230UC/21/SO46</b>	29 80 33 5	10
<b>PLC-BSP-120UC/21/SO46</b>	29 80 35 1	10
<b>PLC-BSP-230UC/21/SO46</b>	29 80 37 7	10
<b>REL-MR-60DC/21AU</b>	29 61 13 4	18
<b>REL-MR-60DC/21</b>	29 61 11 8	18

#### Technical Data<sup>1)</sup>

**Input Data**  
 Nominal input voltage U<sub>N</sub>  
 Permissible range (with reference to U<sub>N</sub> and T<sub>u</sub> = 20°C [68°F])  
 Typical release voltage  
 Typical input current at U<sub>N</sub> (50 Hz/60 Hz)  
 Typical response time/release time at U<sub>N</sub>  
 Input wiring:

**Output Data** (when fitted with...)  
 Contact version  
 Contact material  
 Maximum switching voltage  
 Minimum switching voltage  
 Limiting continuous current  
 Maximum inrush current  
 Minimum switching current  
 Maximum shutdown power, ohmic load:

24 V DC
48 V DC
60 V DC
110 V DC
220 V DC
250 V AC

Minimum switching power

**General Data**  
 Test voltage I/O  
 Ambient operating temperature range  
 Nominal operating mode  
 Flammability class  
 Mechanical life  
 Standards/specifications

Mounting position/mounting

120 V AC	230 V AC
0.8...1.4	0.78...1.14
50 V AC	80 V AC
7/8 mA	8.8/10 mA
7 ms/20 ms	7 ms/20 ms

Operating indicators, bridge rectifier, filter

REL-MR-60DC/21	REL-MR-60DC/21AU
Single contact, 1 Form C contact	Single contact, 1 Form C contact
AgSnO	Ag alloy, hard gold-plated
250 V AC/DC	30 V AC/36 V DC
12 V AC/DC	100 mV
6 A	50 mA
On request	50 mA
10 mA	1 mA
140 W	1.2 W
20 W	-
18 W	-
23 W	-
40 W	-
1500 VA	-
120 mW	100 μW

4 kV, 50 Hz, 1 minute  
 -20°C to +55°C (-4°F to +131°F)  
 100% ED  
 V0 according to UL 94  
 2 x 10<sup>7</sup> cycles  
 IEC 60 664/IEC 60 664 A/DIN VDE 0110, degree of pollution 3, Surge Voltage Category III, DIN EN 50 178/VDE 0160 (in relev. parts), IEC 60 255/DIN VDE 0435 (in relev. parts), DIN VDE 0106-101: 1986-11, reinforced insulation for I/O  
 Any/can be mounted without spacing

# INTERFACE Relay: Resistant Against Interference Voltages and Leakage Currents PLC-...SO46

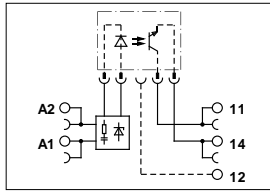

Circuit diagram for DC output

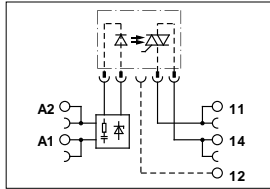

Circuit diagram for AC output



94 mm (3.701 in.)

## PLC-B.../21/SO46

Basic terminal block with integrated filter that can be fitted with a relay or optocoupler

**Note:** Please refer to the INTERFACE catalog for assembly instructions and accessories



M 3

8

	solid [mm <sup>2</sup> ]	flexible [mm <sup>2</sup> ]	AWG	I [A]	U [V]
Connection data	0.14 - 2.5	0.14 - 2.5	26 - 14	*	*

\* The electrical data is determined by the optocoupler.

Description	Input voltage U <sub>N</sub>
<b>PLC interface with screw connection</b> PLC-BSC.../21/SO46 basic terminal block for plug-in OPT-60DC... miniature optocoupler, for mounting on	120 V AC 230 V AC
<b>PLC interface with spring-cage connection</b> PLC-BSP.../21/SO46 basic terminal block for plug-in OPT-60DC... miniature optocoupler, for mounting on	120 V AC 230 V AC
<b>Suitable plug-in miniature optocoupler</b>	

### Technical Data<sup>1)</sup>

#### Input Data

Nominal input voltage U <sub>N</sub>	
Permissible range (with reference to U <sub>N</sub> )	
Switching level	0 signal ("L")
Typical input current at U <sub>N</sub> (50 Hz/60 Hz)	
Typical switch-on time at U <sub>N</sub>	
Typical switch-off time at U <sub>N</sub>	
Input wiring:	

#### Output Data (when fitted with...)

Maximum switching voltage	
Minimum switching voltage	
Limiting continuous current (refer to catalog for derating curve)	
Maximum inrush current	
Output switching	

#### Output wiring

Voltage drop on limiting continuous current	
Leakage current in the off state	
Maximum phase displacement (inductive load)	
Maximum load value I <sup>2</sup> x t (t = 10 ms)	

#### General Data

Test voltage I/O	
Ambient operating temperature range	
Nominal operating mode	
Flammability class	
Standards/specifications	

#### Mounting position/mounting

Housing width 6.2 mm (0.244 in.)

(UL us provided)

<sup>1)</sup>The technical data only applies to basic terminal blocks fitted with a OPT-60DC/24DC/2, OPT-60DC/48DC/100 or OPT-60DC/230AC/1

Type	Order No.	Pcs. Pkt.
<b>PLC-BSC-120UC/21/SO46</b>	<b>29 80 31 9</b>	10
<b>PLC-BSC-230UC/21/SO46</b>	<b>29 80 33 5</b>	10
<b>PLC-BSP-120UC/21/SO46</b>	<b>29 80 35 1</b>	10
<b>PLC-BSP-230UC/21/SO46</b>	<b>29 80 37 7</b>	10
<b>OPT-60DC/48DC/100</b>	<b>29 66 62 1</b>	18
<b>OPT-60DC/24DC/2</b>	<b>29 66 60 5</b>	18
<b>OPT-60DC/230AC/1</b>	<b>29 67 96 3</b>	18

	120 V AC	230 V AC
0.85...1.1	0.85...1.1	0.8...1.1
≤ 0.4 x U <sub>N</sub>	≤ 0.4 x U <sub>N</sub>	≤ 0.4 x U <sub>N</sub>
7/8 mA	7/8 mA	8.8/10 mA
6 ms	6 ms	6 ms
10 ms	10 ms	10 ms
Operating indicators, bridge rectifier, filter		
<b>OPT-60DC/48DC/100</b>	<b>OPT-60DC/24DC/2</b>	<b>OPT-60DC/230AC/1</b>
48 V DC	30 V DC	253 V AC
3 V DC	3 V DC	24 V AC
100 mA	3 A	0.75 A
-	15 A (10 ms)	30 A (10 ms)
2-wire floating ground	2-wire floating ground	2-wire floating ground
Protection against polarity reversal, Surge voltage protection	Protection against polarity reversal, Surge voltage protection	RCV circuit
< 1 V DC	< 200 mV DC	< 1 V DC
-	-	< 1 mA
-	-	cosφ = 0.5
-	-	4.5 A <sup>2</sup> s

2.5 kV, 50 Hz, 1 minute  
 -20°C to +55°C (-4°F to +131°F)  
 100% ED  
 V0 according to UL 94  
 IEC 60 664/IEC 60 664 A/DIN VDE 0110, degree of pollution 2,  
 Surge Voltage Category III  
 Any/can be mounted without spacing

### 3. Technical Data: Sensor Version for Input Signals

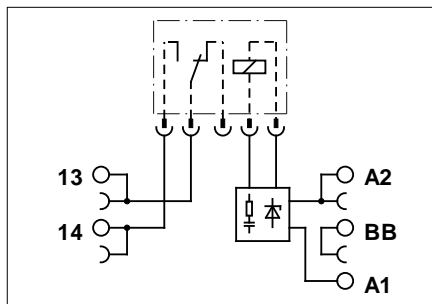

Circuit diagram

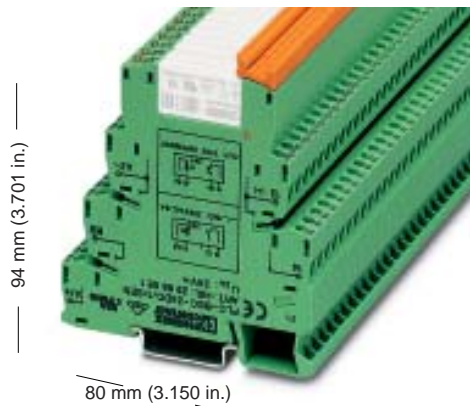

#### PLC-B.../1/SEN/SO46

Basic terminal block with integrated filter that can be fitted with a relay or optocoupler

**Note:** Please refer to the INTERFACE catalog for assembly instructions and accessories



M 3



	solid [mm <sup>2</sup> ]	flexible [mm <sup>2</sup> ]	AWG	I [A]	U [V]
Connection data	0.14 - 2.5	0.14 - 2.5	26 - 14	*	*

\* The electrical data is determined by the relay.

Description	Input voltage U <sub>N</sub>
<b>PLC interface with screw connection</b> PLC-BSC.../1/SEN/SO46 basic terminal block for plug-in REL-MR-60DC... miniature relay, for mounting on	120 V AC 230 V AC
<b>PLC interface with spring-cage connection</b> PLC-BSP.../1/SEN/SO46 basic terminal block for plug-in REL-MR-60DC... miniature relay, for mounting on	120 V AC 230 V AC
<b>Suitable plug-in miniature relay</b>	Gold contact Power contact

#### Technical Data<sup>1)</sup>

##### Input Data

Nominal input voltage U<sub>N</sub>  
Permissible range (with reference to U<sub>N</sub> and T<sub>u</sub> = 20°C [68°F])  
Typical release voltage  
Typical input current at U<sub>N</sub> (50 Hz/60 Hz)  
Typical response time/release time at U<sub>N</sub>  
Input wiring:

##### Output Data (when fitted with...)

Contact version  
Contact material  
Maximum switching voltage  
Minimum switching voltage  
Limiting continuous current  
Maximum inrush current  
Minimum switching current  
Maximum shutdown power, ohmic load:

24 V DC
48 V DC
60 V DC
110 V DC
220 V DC
250 V AC

Minimum switching power

##### General Data

Test voltage I/O  
Ambient operating temperature range  
Nominal operating mode  
Flammability class  
Mechanical life  
Standards/specifications

Mounting position/mounting

Housing width 6.2 mm (0.244 in.)

us provided)

<sup>1)</sup>The technical data only applies to basic terminal blocks fitted with a REL-MR-60DC/21 or REL-MR-60DC/21AU

Type	Order No.	Pcs. Pkt.
<b>PLC-BSC-120UC/1/SEN/SO46</b>	<b>29 80 32 2</b>	10
<b>PLC-BSC-230UC/1/SEN/SO46</b>	<b>29 80 34 8</b>	10
<b>PLC-BSP-120UC/1/SEN/SO46</b>	<b>29 80 36 4</b>	10
<b>PLC-BSP-230UC/1/SEN/SO46</b>	<b>29 80 38 0</b>	10
<b>REL-MR-60DC/21AU</b>	<b>29 61 13 4</b>	18
<b>REL-MR-60DC/21</b>	<b>29 61 11 8</b>	18

120 V AC	230 V AC
0.8...1.4	0.78...1.14
50 V AC	80 V AC
7/8 mA	8.8/10 mA
7 ms/20 ms	7 ms/20 ms

Operating indicators, bridge rectifier, filter

##### REL-MR-60DC/21

Single contact, 1 Form A contact  
AgSnO  
250 V AC/DC  
12 V AC/DC  
6 A  
On request  
10 mA  
140 W  
20 W  
18 W  
23 W  
40 W  
1500 VA  
120 mW

##### REL-MR-60DC/21AU

Single contact, 1 Form A contact  
Ag alloy, hard gold-plated  
30 V AC/36 V DC  
100 mV  
50 mA  
50 mA  
1 mA  
1.2 W  
-  
-  
-  
-  
-  
100 µW

4 kV, 50 Hz, 1 minute  
-20°C to +55°C (-4°F to +131°F)  
100% ED  
V0 according to UL 94  
2 x 10<sup>7</sup> cycles  
IEC 60 664/IEC 60 664 A/DIN VDE 0110, degree of pollution 3, Surge Voltage Category III, DIN EN 50 178/VDE 0160 (in relev. parts), IEC 60 255/DIN VDE 0435 (in relev. parts), DIN VDE 0106-101: 1986-11, reinforced insulation for I/O  
Any/can be mounted without spacing

**INTERFACE Relay: Resistant Against Interference Voltages and Leakage Currents PLC-...SO46**

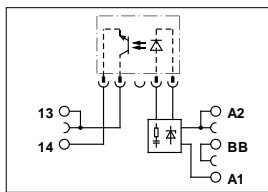

Circuit diagram for DC output

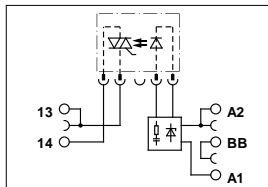

Circuit diagram for AC output

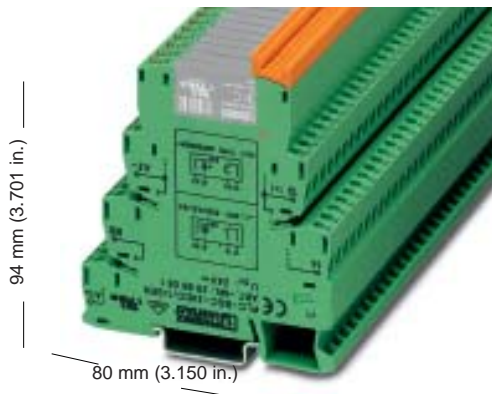

**Note:** Please refer to the INTERFACE catalog for assembly instructions and accessories



M 3

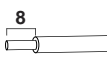

	solid [mm <sup>2</sup> ]	flexible	AWG	I [A]	U [V]
Connection data	0.14 - 2.5	0.14 - 2.5	26 - 14	*	*

\* The electrical data is determined by the optocoupler.

Description	Input voltage U <sub>N</sub>
<b>PLC interface with screw connection</b> PLC-BSC.../1/SEN/SO46 basic terminal block for plug-in OPT-60DC... miniature optocoupler, for mounting on	120 V AC 230 V AC
<b>PLC interface with spring-cage connection</b> PLC-BSP.../1/SEN/SO46 basic terminal block for plug-in OPT-60DC... miniature optocoupler, for mounting on	120 V AC 230 V AC
<b>Suitable plug-in miniature optocoupler</b>	

**Technical Data<sup>1)</sup>**

**Input Data**

Nominal input voltage U <sub>N</sub>	
Permissible range (with reference to U <sub>N</sub> )	
Switching level	0 signal ("L")
Typical input current at U <sub>N</sub> (50 Hz/60 Hz)	
Typical switch-on time at U <sub>N</sub>	
Typical switch-off time at U <sub>N</sub>	
Input wiring:	

**Output Data (when fitted with...)**

Maximum switching voltage	
Minimum switching voltage	
Limiting continuous current (refer to catalog for derating curve)	
Maximum inrush current	
Output switching	

**Output wiring**

Voltage drop on limiting continuous current	
Leakage current in the off state	
Maximum phase displacement (inductive load)	
Maximum load value I <sup>2</sup> x t (t = 10 ms)	

**General Data**

Test voltage I/O	
Ambient operating temperature range	
Nominal operating mode	
Flammability class	
Standards/specifications	

**Mounting position/mounting**

**PLC-B.../1/SEN/SO46**

Basic terminal block with integrated filter that can be fitted with a relay or optocoupler

Housing width 6.2 mm (0.244 in.) (UL us provided)

<sup>1)</sup>The technical data only applies to basic terminal blocks fitted with a OPT-60DC/24DC/2, OPT-60DC/48DC/100 or OPT-60DC/230AC/1

Type	Order No.	Pcs. Pkt.
<b>PLC-BSC-120UC/1/SEN/SO46</b>	<b>29 80 32 2</b>	10
<b>PLC-BSC-230UC/1/SEN/SO46</b>	<b>29 80 34 8</b>	10
<b>PLC-BSP-120UC/1/SEN/SO46</b>	<b>29 80 36 4</b>	10
<b>PLC-BSP-230UC/1/SEN/SO46</b>	<b>29 80 38 0</b>	10
<b>OPT-60DC/48DC/100</b>	<b>29 66 62 1</b>	18
<b>OPT-60DC/24DC/2</b>	<b>29 66 60 5</b>	18
<b>OPT-60DC/230AC/1</b>	<b>29 67 96 3</b>	18

120 V AC	230 V AC	
0.85...1.1	0.8...1.1	
≤ 0.4 x U <sub>N</sub>	≤ 0.4 x U <sub>N</sub>	
7/8 mA	8.8/10 mA	
6 ms	6 ms	
10 ms	10 ms	
Operating indicators, bridge rectifier, filter		
<b>OPT-60DC/48DC/100</b>	<b>OPT-60DC/24DC/2</b>	<b>OPT-60DC/230AC/1</b>
48 V DC	30 V DC	253 V AC
3 V DC	3 V DC	24 V AC
100 mA	3 A	0.75 A
-	5 A (10 ms)	30 A (10 ms)
2-wire floating ground	2-wire floating ground	2-wire floating ground
Protection against polarity reversal,	Protection against polarity reversal,	RCV circuit
Surge voltage protection	Surge voltage protection	
≤ 1 V DC	≤ 200 mV DC	< 1 V AC
-	-	< 1 mA
-	-	cosφ = 0.5
-	-	4.5 A <sup>2</sup> s

2.5 kV, 50 Hz, 1 minute  
 -20°C to +55°C (-4°F to +131°F)  
 100% ED  
 V0 according to UL 94  
 IEC 60 664/IEC 60 664 A/DIN VDE 0110, degree of pollution 2,  
 Surge Voltage Category III  
 Any/can be mounted without spacing



4. Technical Data: Universal SPDT Version

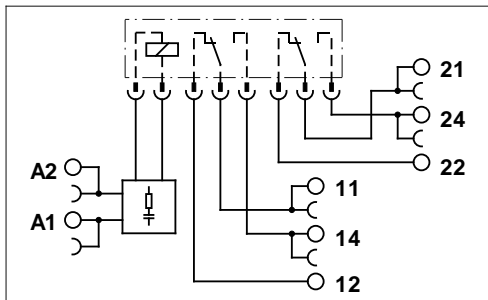

Circuit diagram

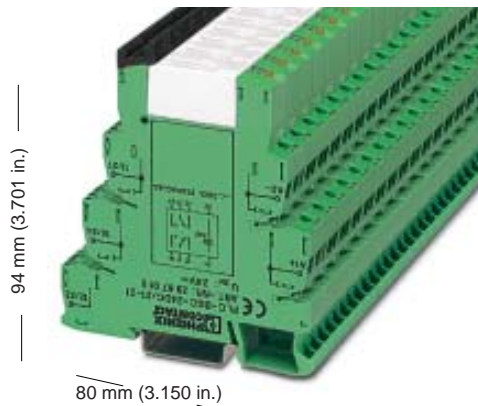

**Note:** Please refer to the INTERFACE catalog for assembly instructions and accessories

M 3	solid	flexible	AWG	I [A]	U [V]
	[mm <sup>2</sup> ]				

Connection data	0.14 - 2.5	0.14 - 2.5	26 - 14	*	*
-----------------	------------	------------	---------	---	---

\* The electrical data is determined by the relay.

Description	Input voltage U <sub>N</sub>
<b>PLC interface with screw connection</b> PLC-BSC.../21-21/SO46 basic terminal block for plug-in REL-MR-110DC... miniature relay, for mounting on	120 V AC 230 V AC
<b>Suitable plug-in miniature relay</b>	Gold contact Power contact

Technical Data<sup>1)</sup>

<b>Input Data</b>	
Nominal input voltage U <sub>N</sub>	
Permissible range (with reference to U <sub>N</sub> and T <sub>u</sub> = 20°C [68°F])	
Typical release voltage	
Typical input current at U <sub>N</sub> (50 Hz/60 Hz)	
Typical response time/release time at U <sub>N</sub>	
Input wiring:	

<b>Output Data (when fitted with...)</b>	
Contact version	
Contact material	
Maximum switching voltage	
Minimum switching voltage	
Limiting continuous current	
Maximum inrush current	
Minimum switching current	
Maximum shutdown power, ohmic load:	24 V DC 48 V DC 60 V DC 110 V DC 220 V DC 250 V AC
Minimum switching power	

<b>General Data</b>	
Test voltage I/O	
Ambient operating temperature range	
Nominal operating mode	
Flammability class	
Mechanical life	
Standards/specifications	
Mounting position/mounting	

**PLC-BSC...21-21/SO46**

Basic terminal block with integrated filter that can be fitted with a relay

Housing width 14 mm (0.244 in.) us provided)

<sup>1)</sup>The technical data only applies to basic terminal blocks fitted with a REL-MR-110DC/21-21 or REL-MR-110DC/21-21AU

Type	Order No.	Pcs. Pkt.
<b>PLC-BSC-120UC/21-21/SO46</b>	<b>29 80 41 6</b>	10
<b>PLC-BSC-230UC/21-21/SO46</b>	<b>29 80 42 9</b>	10
<b>REL-MR-110DC/21-21AU</b>	<b>29 61 22 8</b>	18
<b>REL-MR-110DC/21-21</b>	<b>29 61 20 2</b>	18

120 V AC	230 V AC
0.78...1.4	0.78...1.14
16 V AC	60 V AC
6/7 mA	8.5/10 mA
7 ms/10 ms	7 ms/10 ms
Operating indicators, bridge rectifier, filter	

<b>REL-MR-110DC/21-21</b>	<b>REL-MR-110DC/21-21AU</b>
Single contact, 2 Form C contacts	Single contact, 2 Form C contacts
AgNi	AgNi + 5 μ Au
250 V AC/DC	30 V AC/36 V DC
5 V AC/DC	100 mV
6 A	50 mA
On request	50 mA
10 mA	1 mA
140 W	1.2 W
100 W	-
60 W	-
44 W	-
60 W	-
1500 VA	-
50 mW	100 μW

4 kV, 50 Hz, 1 minute
-20°C to +55°C (-4°F to +131°F)
100% ED
V0 according to UL 94
3 x 10 <sup>7</sup> cycles
IEC 60 664/IEC 60 664 A/DIN VDE 0110, degree of pollution 3, Surge Voltage Category III, DIN EN 50 178/VDE 0160 (in relev. parts), IEC 60 255/DIN VDE 0435 (in relev. parts), DIN VDE 0106-101: 1986-11, reinforced insulation for I/O
Any/can be mounted without spacing

### 5. Technical Data: Universal Version for High Continuous Load Currents

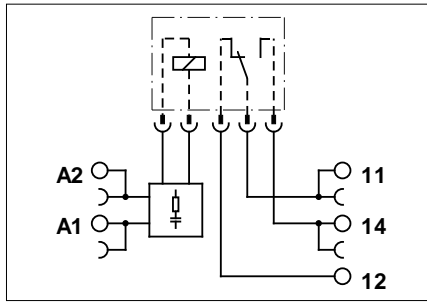

Circuit diagram

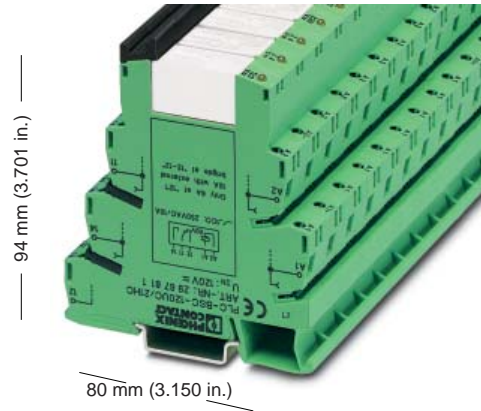

### PLC-BSC...21HC/SO46

Basic terminal block with integrated filter that can be fitted with a relay

**Note:** Please refer to the INTERFACE catalog for assembly instructions and accessories



M 3

8

	solid [mm <sup>2</sup> ]	flexible [mm <sup>2</sup> ]	AWG	I [A]	U [V]
Connection data	0.14 - 2.5	0.14 - 2.5	26 - 14	*	*

\* The electrical data is determined by the relay.

Description	Input voltage U <sub>N</sub>
<b>PLC interface with screw connection</b> PLC-BSC...21HC/SO46 basic terminal block for plug-in REL-MR-110DC... miniature relay, for mounting on	120 V AC 230 V AC
<b>Suitable plug-in miniature relay</b>	Power contact

#### Technical Data<sup>1)</sup>

##### Input Data

Nominal input voltage U<sub>N</sub>  
Permissible range (with reference to U<sub>N</sub> and T<sub>U</sub> = 20°C [68°F])  
Typical release voltage  
Typical input current at U<sub>N</sub> (50 Hz/60 Hz)  
Typical response time/release time at U<sub>N</sub>  
Input wiring:

##### Output Data (when fitted with...)

Contact version  
Contact material  
Maximum switching voltage  
Minimum switching voltage  
Limiting continuous current  
Maximum inrush current  
Minimum switching current  
Maximum shutdown power, ohmic load:

24 V DC
48 V DC
60 V DC
110 V DC
220 V DC
250 V AC

Minimum switching power

##### General Data

Test voltage I/O  
Ambient operating temperature range  
Nominal operating mode  
Flammability class  
Mechanical life  
Standards/specifications

Mounting position/mounting

<sup>1)</sup> Input wiring depends on the type

Housing width 14 mm (0.244 in.)

us provided

<sup>1)</sup>The technical data only applies to basic terminal blocks fitted with a REL-MR-110DC/21HC

Type	Order No.	Pcs. Pkt.
PLC-BSC-120UC/21HC/SO46	29 80 43 2	10
PLC-BSC-230UC/21HC/SO46	29 80 44 5	10
REL-MR-110DC/21HC	29 61 33 8	18

120 V AC  
0.85...1.4  
16 V AC  
6/7 mA  
7 ms/10 ms  
Operating indicators, bridge rectifier, filter

##### REL-MR-110DC/21HC

Single contact, 1 Form C contact  
AgNi  
250 V AC/DC  
12 V AC/DC  
10 (6) A<sup>2)</sup>  
16 A  
100 mA  
240 (144) W<sup>2)</sup>  
58 W  
48 W  
50 W  
80 W  
2500 (1500) VA<sup>2)</sup>  
1.2 W

4 kV, 50 Hz, 1 minute  
-20°C to +55°C (-4°F to +131°F)  
100% ED  
V0 according to UL 94  
3 x 10<sup>7</sup> cycles  
IEC 60 664/IEC 60 664 A/DIN VDE 0110, degree of pollution 3, Surge Voltage Category III, DIN EN 50 178/VDE 0160 (in relev. parts), IEC 60 255/DIN VDE 0435 (in relev. parts), DIN VDE 0106-101: 1986-11, reinforced insulation for I/O  
Any/can be mounted without spacing

<sup>2)</sup>The values in brackets are for connections 12.  
If connections 12 are jumpered, the values in brackets are valid.

## Данный компонент на территории Российской Федерации

### Вы можете приобрести в компании MosChip.

Для оперативного оформления запроса Вам необходимо перейти по данной ссылке:

<http://moschip.ru/get-element>

Вы можете разместить у нас заказ для любого Вашего проекта, будь то серийное производство или разработка единичного прибора.

В нашем ассортименте представлены ведущие мировые производители активных и пассивных электронных компонентов.

Нашей специализацией является поставка электронной компонентной базы двойного назначения, продукции таких производителей как XILINX, Intel (ex.ALTERA), Vicor, Microchip, Texas Instruments, Analog Devices, Mini-Circuits, Amphenol, Glenair.

Сотрудничество с глобальными дистрибьюторами электронных компонентов, предоставляет возможность заказывать и получать с международных складов практически любой перечень компонентов в оптимальные для Вас сроки.

На всех этапах разработки и производства наши партнеры могут получить квалифицированную поддержку опытных инженеров.

Система менеджмента качества компании отвечает требованиям в соответствии с ГОСТ Р ИСО 9001, ГОСТ РВ 0015-002 и ЭС РД 009

### Офис по работе с юридическими лицами:

105318, г.Москва, ул.Щербаковская д.3, офис 1107, 1118, ДЦ «Щербаковский»

Телефон: +7 495 668-12-70 (многоканальный)

Факс: +7 495 668-12-70 (доб.304)

E-mail: [info@moschip.ru](mailto:info@moschip.ru)

Skype отдела продаж:

moschip.ru

moschip.ru\_4

moschip.ru\_6

moschip.ru\_9