



MCP3423
Evaluation Board
User's Guide

Note the following details of the code protection feature on Microchip devices:

- Microchip products meet the specification contained in their particular Microchip Data Sheet.
- Microchip believes that its family of products is one of the most secure families of its kind on the market today, when used in the intended manner and under normal conditions.
- There are dishonest and possibly illegal methods used to breach the code protection feature. All of these methods, to our knowledge, require using the Microchip products in a manner outside the operating specifications contained in Microchip's Data Sheets. Most likely, the person doing so is engaged in theft of intellectual property.
- Microchip is willing to work with the customer who is concerned about the integrity of their code.
- Neither Microchip nor any other semiconductor manufacturer can guarantee the security of their code. Code protection does not mean that we are guaranteeing the product as "unbreakable."

Code protection is constantly evolving. We at Microchip are committed to continuously improving the code protection features of our products. Attempts to break Microchip's code protection feature may be a violation of the Digital Millennium Copyright Act. If such acts allow unauthorized access to your software or other copyrighted work, you may have a right to sue for relief under that Act.

Information contained in this publication regarding device applications and the like is provided only for your convenience and may be superseded by updates. It is your responsibility to ensure that your application meets with your specifications. MICROCHIP MAKES NO REPRESENTATIONS OR WARRANTIES OF ANY KIND WHETHER EXPRESS OR IMPLIED, WRITTEN OR ORAL, STATUTORY OR OTHERWISE, RELATED TO THE INFORMATION, INCLUDING BUT NOT LIMITED TO ITS CONDITION, QUALITY, PERFORMANCE, MERCHANTABILITY OR FITNESS FOR PURPOSE. Microchip disclaims all liability arising from this information and its use. Use of Microchip devices in life support and/or safety applications is entirely at the buyer's risk, and the buyer agrees to defend, indemnify and hold harmless Microchip from any and all damages, claims, suits, or expenses resulting from such use. No licenses are conveyed, implicitly or otherwise, under any Microchip intellectual property rights.

Trademarks

The Microchip name and logo, the Microchip logo, Accuron, dsPIC, KEELOQ, KEELOQ logo, MPLAB, PIC, PICmicro, PICSTART, rPIC, SmartShunt and UNI/O are registered trademarks of Microchip Technology Incorporated in the U.S.A. and other countries.

FilterLab, Linear Active Thermistor, MXDEV, MXLAB, SEEVAL, SmartSensor and The Embedded Control Solutions Company are registered trademarks of Microchip Technology Incorporated in the U.S.A.

Analog-for-the-Digital Age, Application Maestro, CodeGuard, dsPICDEM, dsPICDEM.net, dsPICworks, dsSPEAK, ECAN, ECONOMONITOR, FanSense, In-Circuit Serial Programming, ICSP, ICEPIC, Mindi, MiWi, MPASM, MPLAB Certified logo, MPLIB, MPLINK, mTouch, PICkit, PICDEM, PICDEM.net, PICTail, PIC³² logo, PowerCal, PowerInfo, PowerMate, PowerTool, REAL ICE, rLAB, Select Mode, Total Endurance, WiperLock and ZENA are trademarks of Microchip Technology Incorporated in the U.S.A. and other countries.

SQTP is a service mark of Microchip Technology Incorporated in the U.S.A.

All other trademarks mentioned herein are property of their respective companies.

© 2008, Microchip Technology Incorporated, Printed in the U.S.A., All Rights Reserved.

 Printed on recycled paper.

QUALITY MANAGEMENT SYSTEM
CERTIFIED BY DNV
== ISO/TS 16949:2002 ==

Microchip received ISO/TS-16949:2002 certification for its worldwide headquarters, design and wafer fabrication facilities in Chandler and Tempe, Arizona; Gresham, Oregon and design centers in California and India. The Company's quality system processes and procedures are for its PIC[®] MCUs and dsPIC[®] DSCs, KEELOQ[®] code hopping devices, Serial EEPROMs, microperipherals, nonvolatile memory and analog products. In addition, Microchip's quality system for the design and manufacture of development systems is ISO 9001:2000 certified.



MCP3423 EVALUATION BOARD USER'S GUIDE

Table of Contents

Preface	1
Introduction.....	1
Document Layout	1
Conventions Used in this Guide	2
Recommended Reading.....	3
The Microchip Web Site	3
Customer Support	3
Document Revision History	3
Chapter 1. Quick Start Instructions	
1.1 Introduction	5
1.2 Description of the MCP3423 Evaluation Board	5
1.3 Getting Started with PICKit Serial Analyzer	6
1.4 Experiment for CH2	22
Appendix A. Schematic and Layouts	
A.1 Introduction	23
A.2 Board – Schematic	24
A.3 Board – Top Layer	25
A.4 Board – Top Metal Layer	26
A.5 Board – Bottom Layer	27
A.6 Board – Bottom Metal Layer	28
Appendix B. Bill of Materials (BOM)	
Worldwide Sales and Service	30

MCP3423 Evaluation Board User's Guide

NOTES:

Preface

NOTICE TO CUSTOMERS

All documentation becomes dated, and this manual is no exception. Microchip tools and documentation are constantly evolving to meet customer needs, so some actual dialogs and/or tool descriptions may differ from those in this document. Please refer to our web site (www.microchip.com) to obtain the latest documentation available.

Documents are identified with a “DS” number. This number is located on the bottom of each page, in front of the page number. The numbering convention for the DS number is “DSXXXXA”, where “XXXX” is the document number and “A” is the revision level of the document.

For the most up-to-date information on development tools, see the MPLAB® IDE on-line help. Select the Help menu, and then Topics to open a list of available on-line help files.

INTRODUCTION

This chapter contains general information that will be useful to know before using the MCP3423 Evaluation Board. Items discussed in this chapter include:

- Document Layout
- Conventions Used in this Guide
- Recommended Reading
- The Microchip Web Site
- Customer Support
- Document Revision History

DOCUMENT LAYOUT

This document describes how to use the MCP3423 Evaluation Board as a development tool to emulate and debug firmware on a target board. The manual layout is as follows:

- **Chapter 1. “Quick Start Instructions”** – this chapter provides an overview of the MCP3423 Evaluation Board and instructions on how to use the MCP3423 Evaluation Board with the PICkit Serial Analyzer.
- **Appendix A. “Schematic and Layouts”** – shows the schematic and layout diagrams for the MCP3423 Evaluation Board.
- **Appendix B. “Bill of Materials (BOM)”** – lists the parts used to build the MCP3423 Evaluation Board.

MCP3423 Evaluation Board User's Guide

CONVENTIONS USED IN THIS GUIDE

This manual uses the following documentation conventions:

DOCUMENTATION CONVENTIONS

Description	Represents	Examples
Arial font:		
Italic characters	Referenced books	<i>MPLAB[®] IDE User's Guide</i>
	Emphasized text	...is the <i>only</i> compiler...
Initial caps	A window	the Output window
	A dialog	the Settings dialog
	A menu selection	select Enable Programmer
Quotes	A field name in a window or dialog	"Save project before build"
Underlined, italic text with right angle bracket	A menu path	<u><i>File>Save</i></u>
Bold characters	A dialog button	Click OK
	A tab	Click the Power tab
N'Rnnnn	A number in verilog format, where N is the total number of digits, R is the radix and n is a digit.	4'b0010, 2'hF1
Text in angle brackets < >	A key on the keyboard	Press <Enter>, <F1>
Courier New font:		
Plain Courier New	Sample source code	#define START
	Filenames	autoexec.bat
	File paths	c:\mcc18\h
	Keywords	_asm, _endasm, static
	Command-line options	-Opa+, -Opa-
	Bit values	0, 1
	Constants	0xFF, 'A'
Italic Courier New	A variable argument	<i>file.o</i> , where <i>file</i> can be any valid filename
Square brackets []	Optional arguments	mcc18 [options] <i>file</i> [options]
Curly brackets and pipe character: { }	Choice of mutually exclusive arguments; an OR selection	errorlevel {0 1}
Ellipses...	Replaces repeated text	var_name [, var_name...]
	Represents code supplied by user	void main (void) { ... }

RECOMMENDED READING

This user's guide describes how to use MCP3423 Evaluation Board. Other useful documents are listed below. The following Microchip document is available and recommended as supplemental reference resources:

PICkit™ Serial Analyzer User's Guide (DS51647)

Consult this document for instructions on how to use the PICkit Serial Analyzer hardware and software.

MCP3422/3/4 Data Sheet, "18-Bits, Multi-Channel Delta-Sigma Analog-to-Digital Converter with I²C Interface and On-Board Reference" (DS22088)

This data sheet provides detailed information regarding the MCP3423 product family.

THE MICROCHIP WEB SITE

Microchip provides online support via our web site at www.microchip.com. This web site is used as a means to make files and information easily available to customers. Accessible by using your favorite Internet browser, the web site contains the following information:

- **Product Support** – Data sheets and errata, application notes and sample programs, design resources, user's guides and hardware support documents, latest software releases and archived software
- **General Technical Support** – Frequently Asked Questions (FAQs), technical support requests, online discussion groups, Microchip consultant program member listing
- **Business of Microchip** – Product selector and ordering guides, latest Microchip press releases, listing of seminars and events, listings of Microchip sales offices, distributors and factory representatives

CUSTOMER SUPPORT

Users of Microchip products can receive assistance through several channels:

- Distributor or Representative
- Local Sales Office
- Field Application Engineer (FAE)
- Technical Support

Customers should contact their distributor, representative or field application engineer (FAE) for support. Local sales offices are also available to help customers. A listing of sales offices and locations is included in the back of this document.

Technical support is available through the web site at: <http://support.microchip.com>.

DOCUMENT REVISION HISTORY

Revision A (November 2008)

- Initial Release of this Document.

MCP3423 Evaluation Board User's Guide

NOTES:

Chapter 1. Quick Start Instructions

1.1 INTRODUCTION

The following sections provide an overview of the MCP3423 Evaluation Board and demonstrate how to use it with the PICkit™ Serial Analyzer (P/N: DV164122).

The following topics are covered:

- Description of the MCP3423 Evaluation Board
- How to use MCP3423 Evaluation Board with the PICkit Serial Analyzer

1.2 DESCRIPTION OF THE MCP3423 EVALUATION BOARD

The MCP3423 Evaluation Board (P/N MCP3423EV) contains a MCP3423 18-Bit $\Delta\Sigma$ Analog-to-Digital Converter (ADC). The MCP3423 is a 2-channel 18 bit delta-sigma ADC device with various configuration options. The board has analog input connection pads and various test pads.

The user can connect inputs and test the conversion results using the PICkit Serial Analyzer and its PC graphic user interface (GUI). The MCP3423 Evaluation Board has the following interfaces:

- PICkit Serial Analyzer (P/N: DV164122) for writing configuration register bits and reading the conversion data.

<p>Note: The user can use this board without the PICkit Serial Analyzer as long as the V_{DD}, SCL, and SDA are provided through J1 connector. This Evaluation Board does not include MCU.</p>
--

The board has test points for SDL, SDA, and analog inputs. By connecting an oscilloscope to these test points, the user can examine the data communications through the I²C™ bus line and observe the resulting conversion output. Refer to **Appendix A. "Schematic and Layouts"**.

1.2.1 I²C Address Bits and A0 Address Bit Selection

The I²C device code and address bits of the MCP3423 device are:

- Device Code: '1101'
- A2, A1, A0 Address Bits: determined by the JP2 (Adr1 pin) and JP3 (Adr0 pin).
- See Table 1-1 for the I²C Device Address bits and JP2 and JP3 connections.

MCP3423 Evaluation Board User's Guide

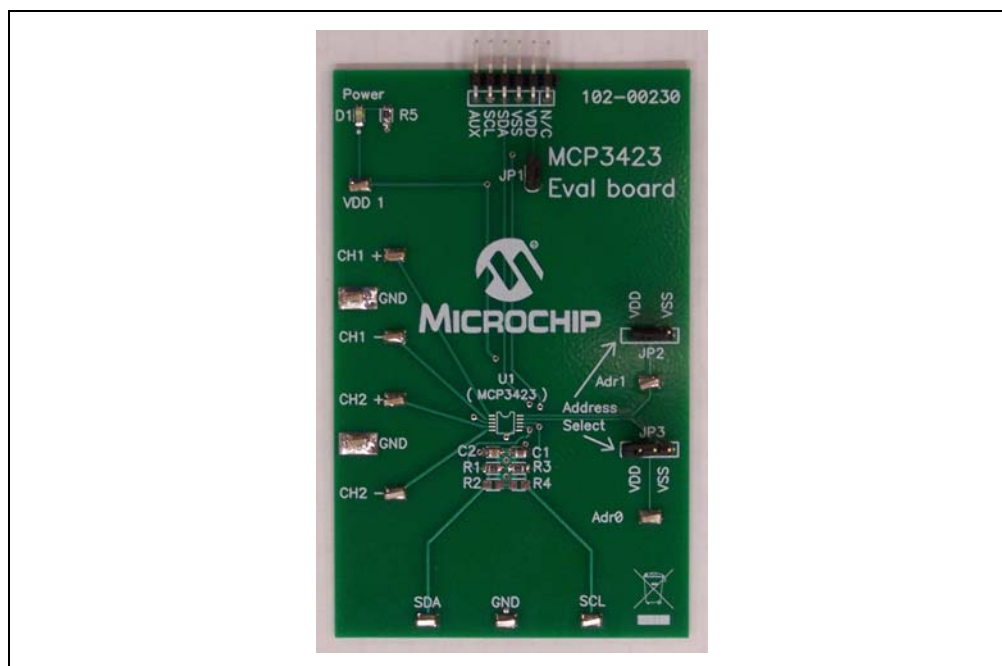

FIGURE 1-1: Front View of the MCP3423 Evaluation Board.

1.3 GETTING STARTED WITH PICKIT SERIAL ANALYZER

Figure 1-1 shows the MCP3423 Evaluation Board, and Figure 1-2 shows the MCP3423 and PICKit Serial Analyzer.

The following describes how to use them together:

1. Connect the MCP3423 Evaluation Board's 6-pin socket to the PICKit Serial Analyzer as shown in Figure 1-2.
2. Connect the oscilloscope probes to the SCL and SDA test pins (optional).
3. V_{DD} Selection: You can use the V_{DD} from the PICKit Serial Analyzer or use your own external V_{DD} . The JP1 connector selects the V_{DD} path.
 - (a) Connect JP1, if using V_{DD} from PICKit Serial Analyzer.
 - (b) Disconnect JP1 and apply V_{DD} at V_{DD1} pin, if you are using an external V_{DD} .
4. Address bit selection using JP2 and JP3 connectors.

The I²C device code and address bits of the MCP3423 device are:

- MCP3423 I²C device code: `1101`
 - A2, A1, A0 Address Bits: determined by the JP2 (Adr1 pin) and JP3 (Adr0 pin)
 - The JP2 and JP3 connectors are external address bit selections. Connect these pins to V_{SS} , V_{DD} , float, or connect any arbitrary voltage
 - See Table 1-1 for the I²C Device Address bits and JP2 and JP3 connections
5. **Connecting V_{DD} :** LED D1 turns on when V_{DD} is applied. The PICKit Serial Analyzer will provide V_{DD} automatically, if it is connected to the PC. Make sure LED D1 turns on, when you execute the command using the PICKit Serial Analyzer.

Quick Start Instructions

6. **Connecting the analog inputs:** If you need to measure a single-ended input, connect the unused pin (example, CHx-) to V_{SS} .
- **Connecting the inputs:** The MCP3423 Evaluation Board has input pads for two analog input channels. You can connect all inputs at the same time and multiplex the input channel using configuration register settings. You can also leave the unused channel inputs floating.
7. Use the PICkit Serial Analyzer PC GUI to send I²C write and read commands.

CAUTION
<p>Each analog input pin has an ESD diode. Certain input conditions can damage the device. Please use the following conditions:</p> <p>(a) Do not apply an input greater than the input range specified by the MCP3423 Data Sheet.</p> <p>(b) Apply the input signal after V_{DD} is powered-up.</p>

TABLE 1-1: I²C ADDRESS BITS VS. JP2 AND JP3 CONNECTORS

I ² C Device Address Bits	JP2 (Adr1 Pin)	JP3 (Adr0 Pin)
1101 000 $\overline{W/R}$	Connected to V_{SS}	Connected to V_{SS}
1101 001 $\overline{W/R}$	Connected to V_{SS}	Float
1101 010 $\overline{W/R}$	Connected to V_{SS}	Connected to V_{DD}
1101 100 $\overline{W/R}$	Connected to V_{DD}	Connected to V_{SS}
1101 101 $\overline{W/R}$	Connected to V_{DD}	Float
1101 110 $\overline{W/R}$	Connected to V_{DD}	Connected to V_{DD}
1101 011 $\overline{W/R}$	Float	Connected to V_{SS}
1101 111 $\overline{W/R}$	Float	Connected to V_{DD}
1101 000 $\overline{W/R}$	Float	Float

- Note 1:** $\overline{W/R}$ bit = "0" for writing, "1" for reading.
- Note 2:** Float: (a) Leave pin without connecting to anything, or (b) apply Addr_Float voltage. See MCP3423 Data Sheet for more details.

MCP3423 Evaluation Board User's Guide

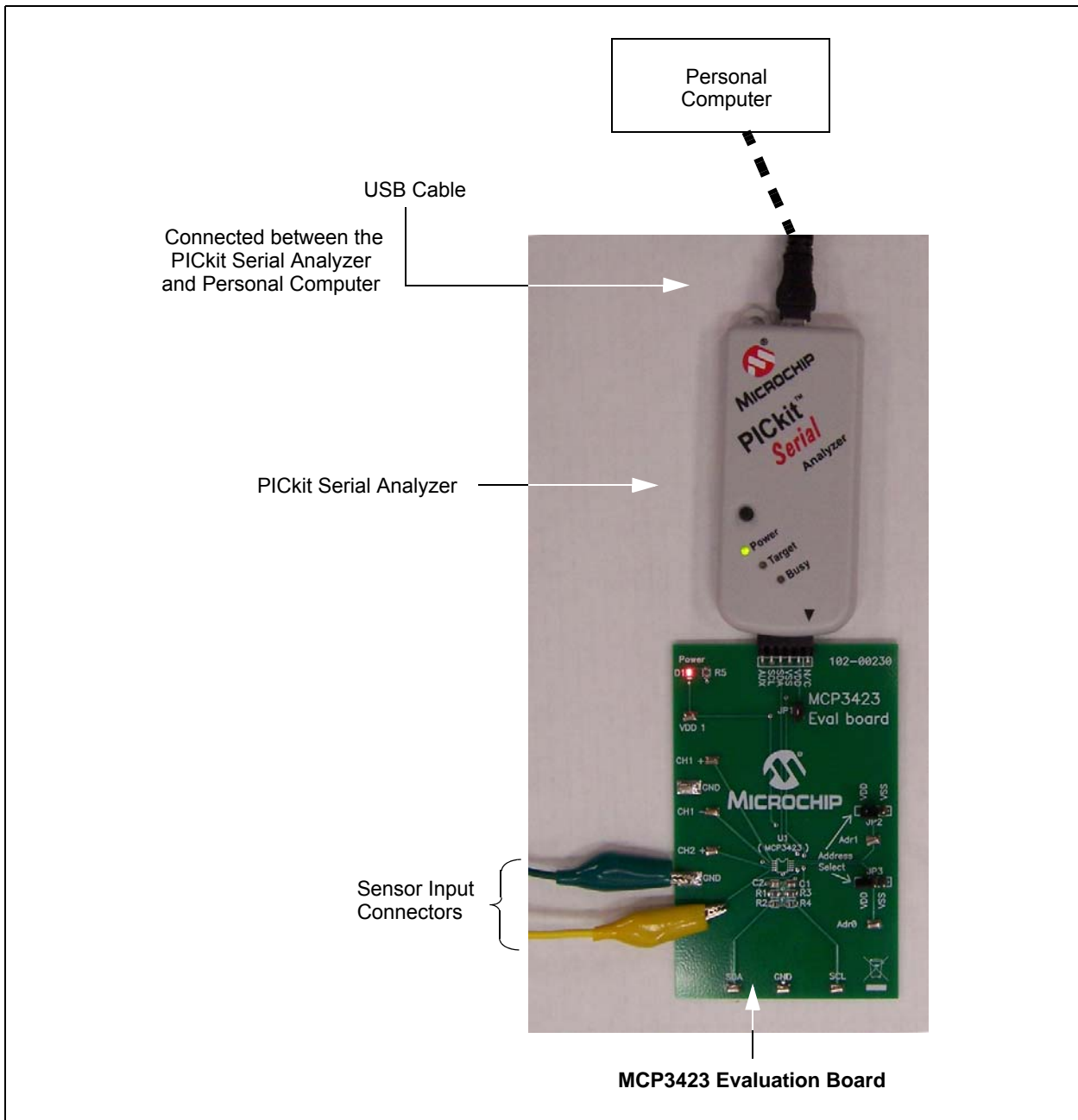

FIGURE 1-2: MCP3423 Evaluation Board with the PICkit Serial Analyzer.

1.3.1 PICkit Serial Analyzer PC Software Setup for the MCP3423 Evaluation Board

The following steps describe how to set up and use the PICkit Serial Analyzer PC Graphic User Interface (GUI).

1. Install the PICkit Serial Analyzer software onto your personal computer (PC).
2. Connect the USB cable between the PICkit Serial Analyzer and the PC.
3. Run the PICkit Serial PC Software - it will open to the following GUI:



FIGURE 1-3: PICkit Serial Analyzer Configuration Window welcome window.

Click the **Next** button and follow the instructions.

4. Select the Communication Mode type: **I2C Master**, and click the **Next** button.

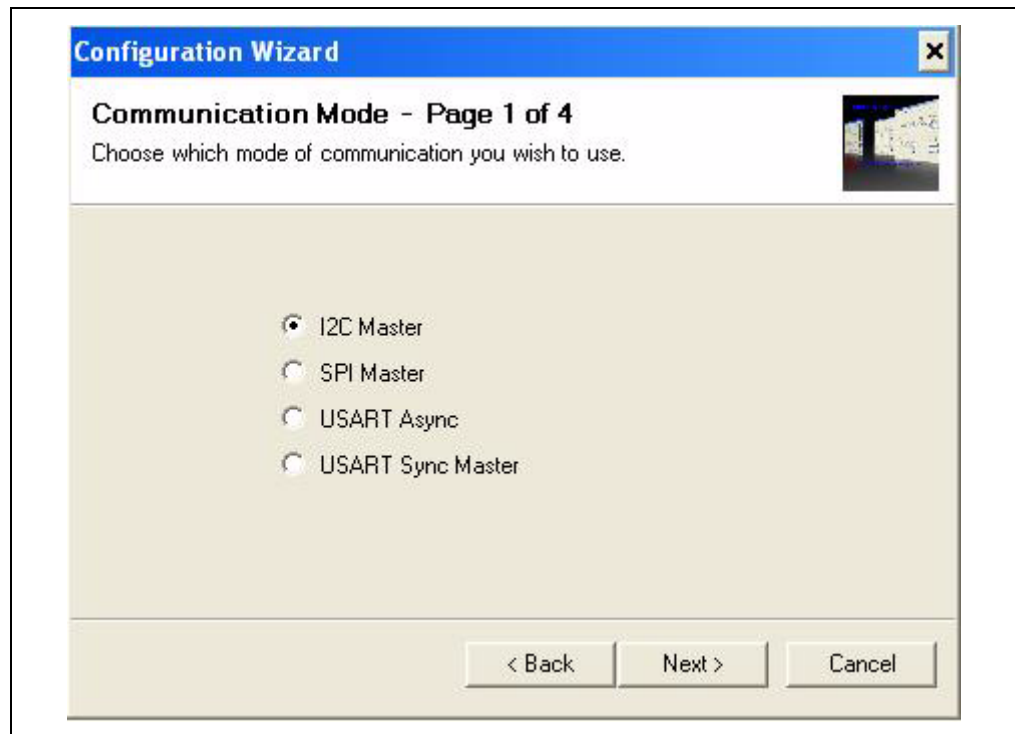

FIGURE 1-4: Step 1 - Communication Mode selection.

MCP3423 Evaluation Board User's Guide

5. In the new window, select "100 kHz" or "400 kHz". Either one will be fine. Click the **Next** button.

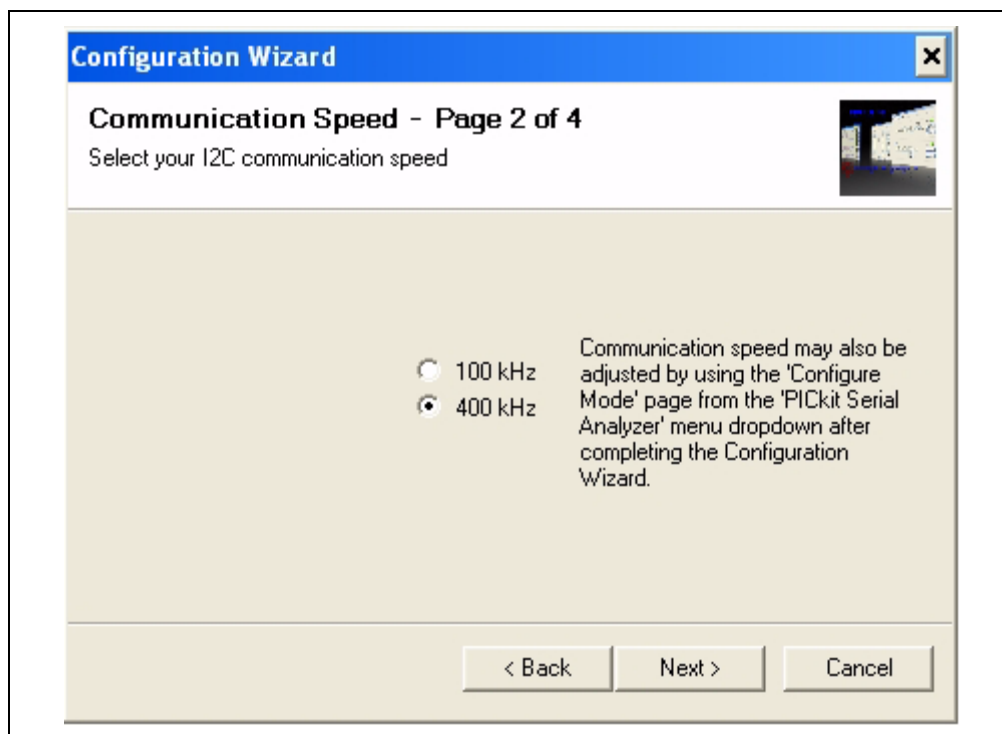

FIGURE 1-5: Step 2 - I²C Communication Speed window.

Note: The MCP3423 device supports the I²C bus data rate up to 3.4 MHz, but the current version of the PICkit Serial Analyzer supports the I²C bus data rate up to 400 kHz only.

- In the Device Pullups window, select **No** on “Enable Pull-ups” and click the **Next** button.

Note: The MCP3423 Evaluation Board has its own pull-up resistors.

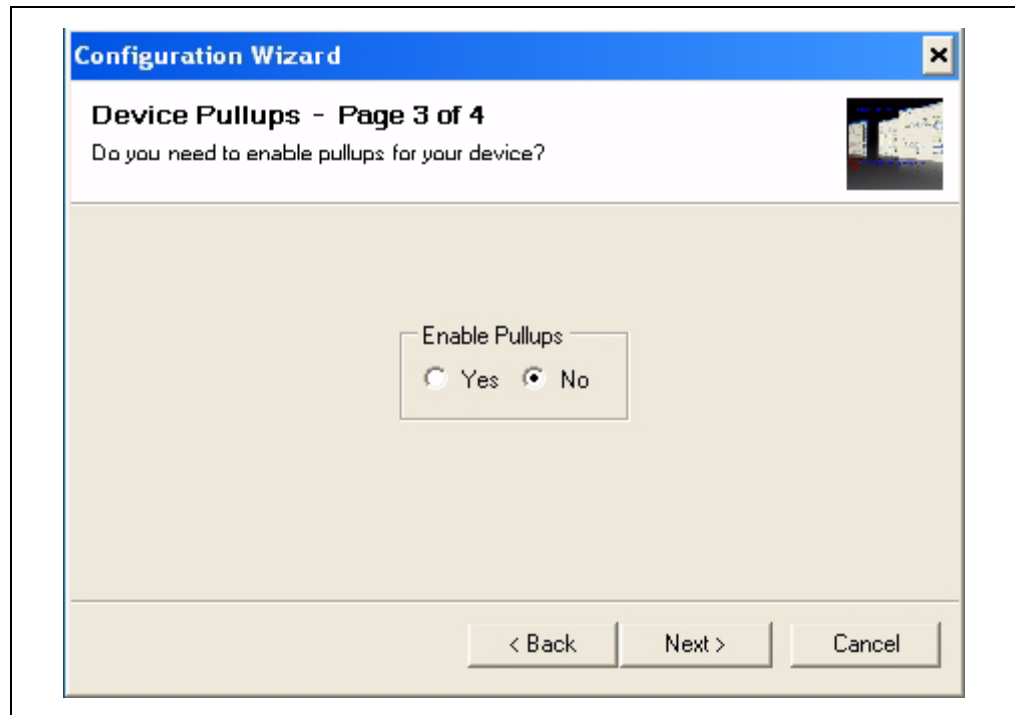

FIGURE 1-6: Step 3 - Device Pullups window.

- In this step, you have to select the V_{DD} voltage of the MCP3423 Evaluation Board, then click the **Next** button.

Case 1: When you use V_{DD} from the PICKit Serial Analyzer:

If you choose **PICKit Serial will power your device** and **5 Volts** as shown in Figure 1-7, the MCP3423 Evaluation Board is powered by the 5V DC from the PICKit Serial Analyzer through the JP1 jumper. In this case, make sure that the JP1 jumper on the MCP3423 Evaluation Board is connected.

Case 2: When you use your own V_{DD} :

You can also provide your own V_{DD} voltage by applying a V_{DD} voltage at VD1 test point. In this case, make sure that the JP1 jumper is disconnected.

MCP3423 Evaluation Board User's Guide

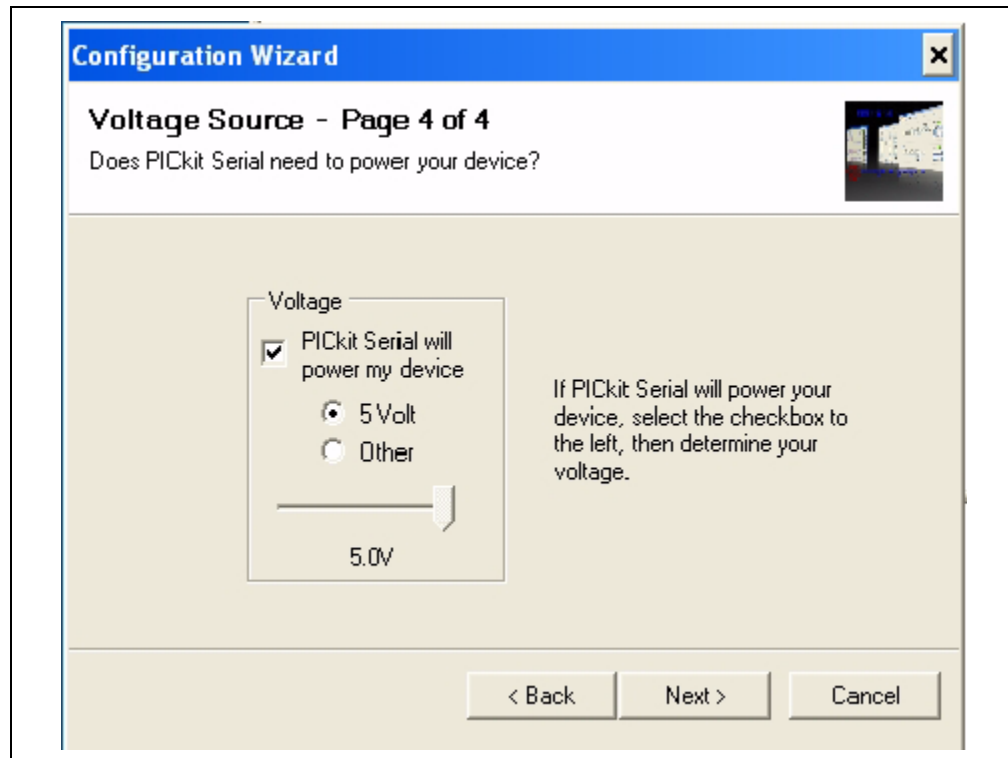

FIGURE 1-7: Step 4 - Voltage Source selection window.

8. Click the **OK** button. You have made all of the PICkit Serial Analyzer Configuration Setups. You are now ready to program the MCP3423 Evaluation Board using the PICkit Serial Analyzer.

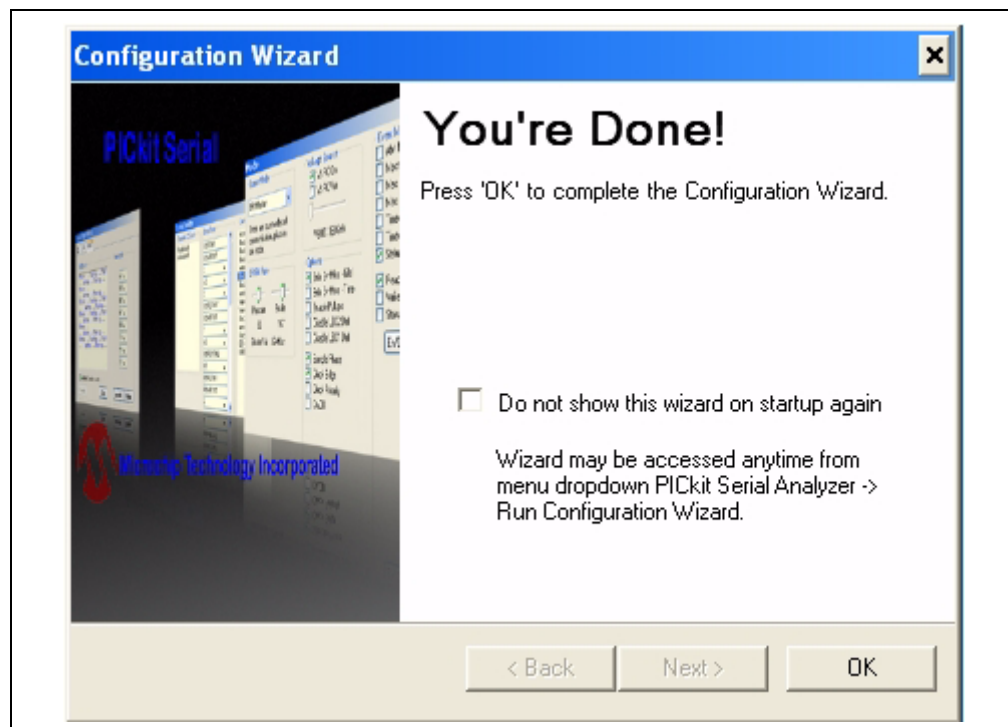

FIGURE 1-8: Configuration Wizard - Finishing step.

1.3.2 Creating Script Files

In order to make a communication connection between the PICkit Serial Analyzer and the MCP3423 Evaluation Board, a script file is needed. Figure 1-9 shows how to create script files and how to use them.

- In the PICkit Serial Analyzer window, select from the menu Communications>Script>Script Builder.

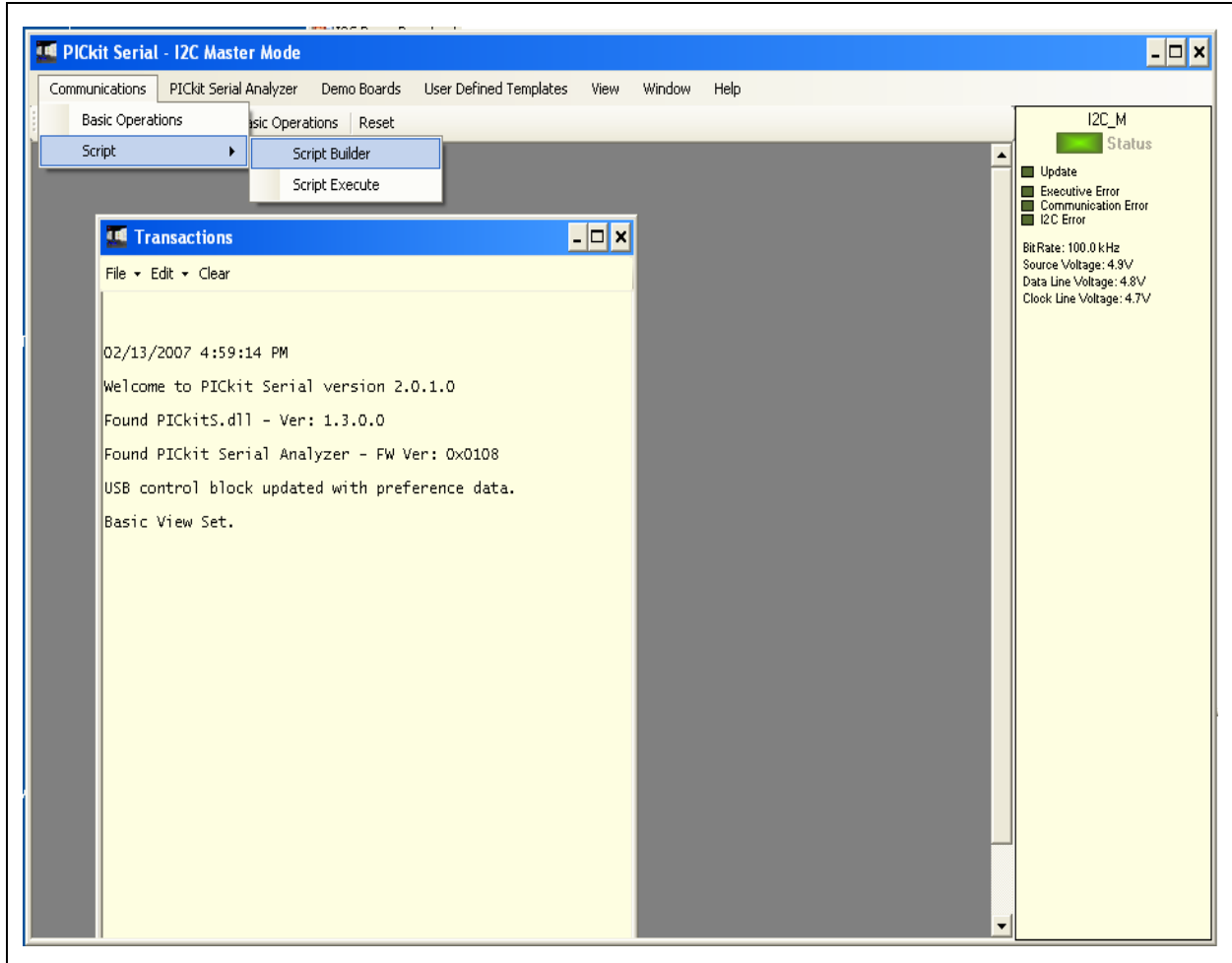

FIGURE 1-9: Creating a script file with Script Builder.

1.3.2.1 CREATING SCRIPT FILE FOR CONFIGURATION BYTE WRITING

1. Click on **WriteBlockAddrA8** in “Example I²C Scripts” column.
This will result in filling in the spaces under the “Script Detail” column.
You can now modify the “Script Detail” column parameters by right-clicking the mouse.

How to modify the parameters box in Script Details:

1. Under the “Script Detail” box, select the item in the parameter box.
2. Right click the mouse button and an option box appears to the right of your selection. These are the options available for the parameter selected.
3. Select the desired option and delete or insert the parameter box.
4. Keep the parameters in order as shown in Figure 1-10:

MCP3423 Evaluation Board User's Guide

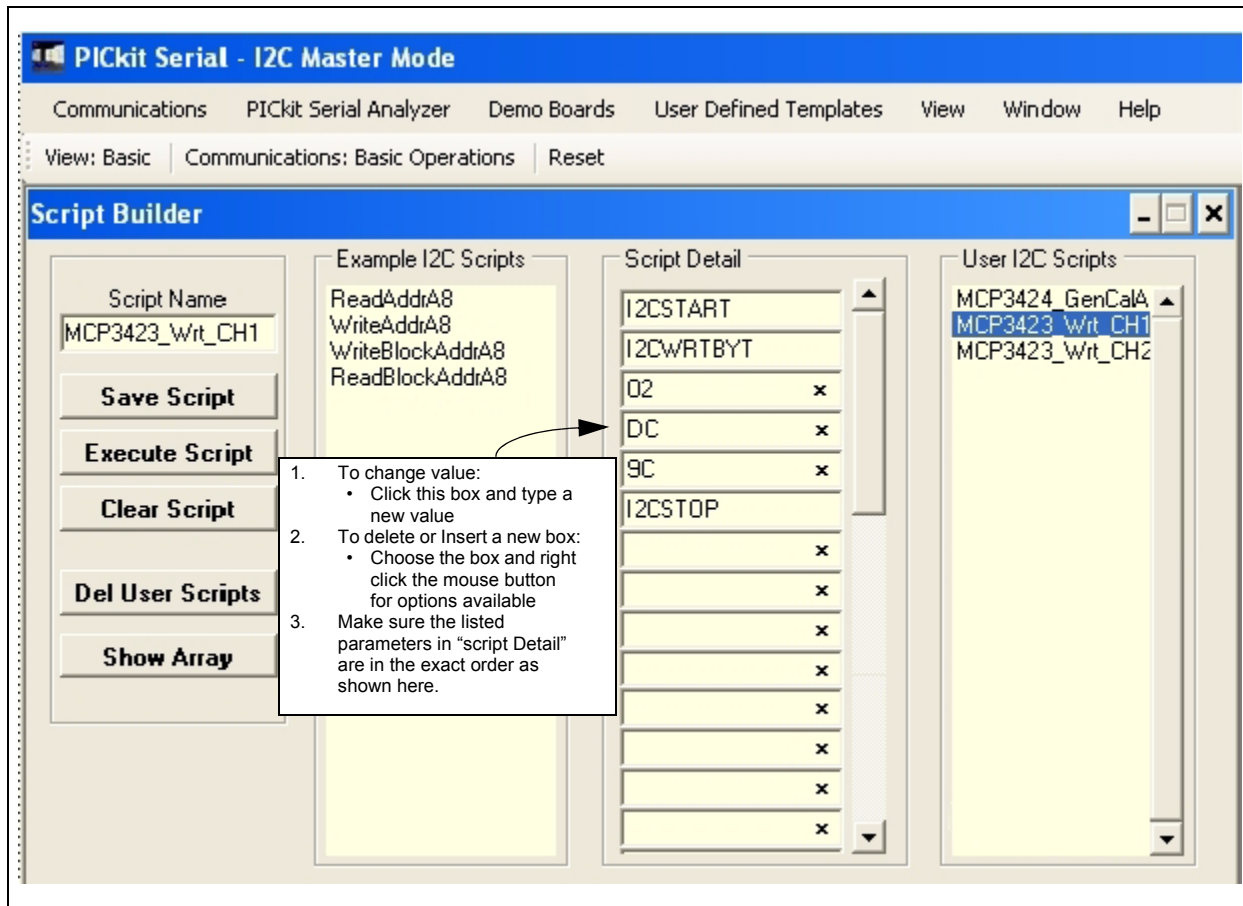

FIGURE 1-10: Modifying parameters in Script Builder window.

- Change the parameter value:

Script Detail	
I2CSTART	*
I2CWRTBYT	*
02	→ This means there are two bytes to send
DC	→ 1st Write Byte: Address byte with W/R bit = 1101-1100
9C	→ 2nd Write Byte: 1001-1100
I2CSTOP	*

Note: All six parameters above must be listed in order. The parameter above marked with * character are not modifiable. Address bits (A2, A1, A0) = (1,1,0) if both JP2 and JP3 are tied to V_{DD}. You can use different address bits by rearranging the connectors. See MCP3423 Data Sheet for more information on address bit sections.

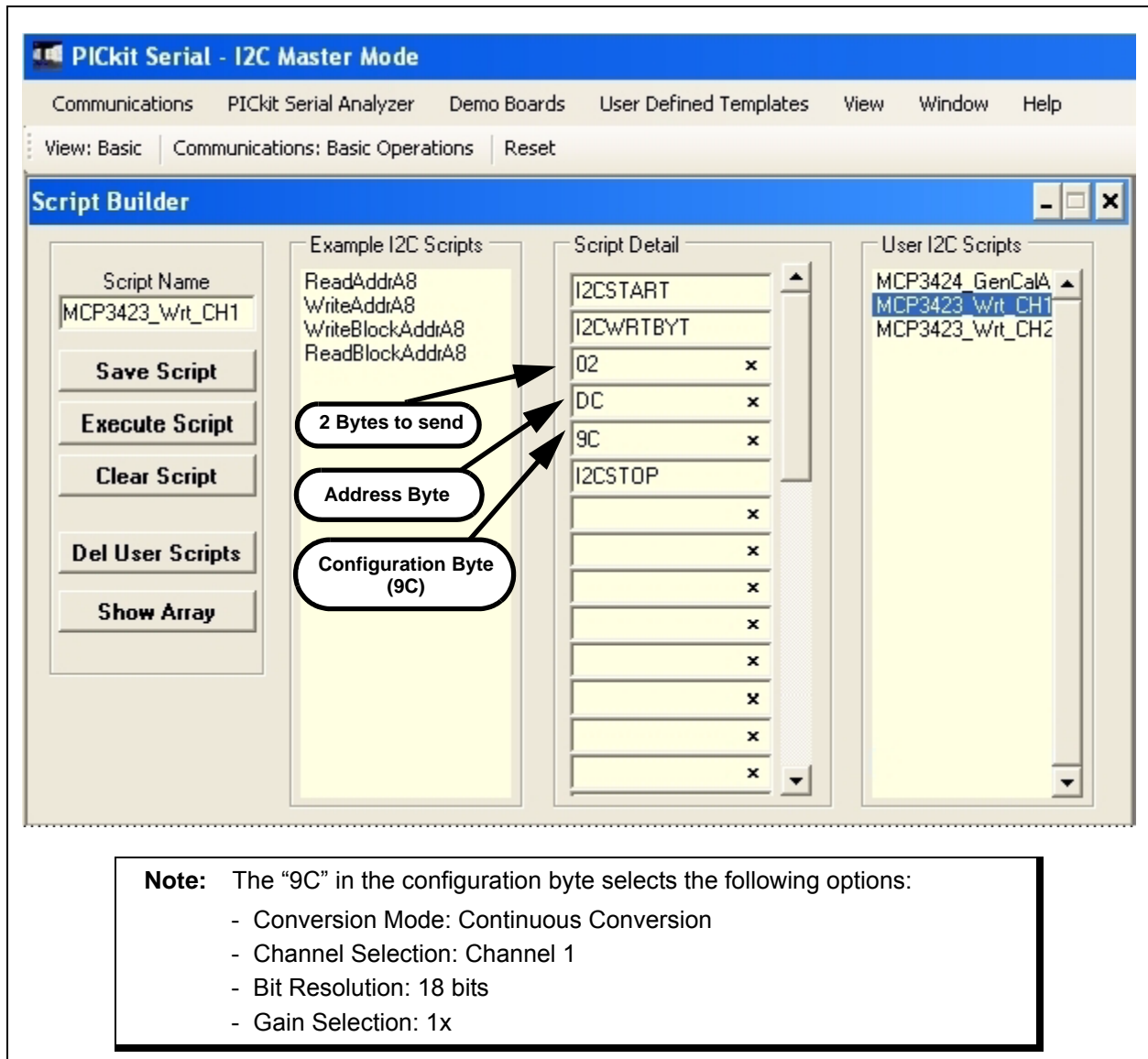

FIGURE 1-11: Script file example for I²C Write Command.

1.3.2.2 SAVE THE SCRIPT FILE AND PROGRAMMING THE MCP3423 CONFIGURATION REGISTER

1. Change the 2nd and 3rd data bytes you want in the Script Detail.
2. Type in any script name (i.e., MCP3423_Write) in the space below the “Script Name” menu.
3. Click **Save Script** button.
4. Click **Execute Script** button.

Note: At this point, the PICKit Serial transmits the I²C Write Command to the MCP3423 device. The saved file name will appear in “Users I2C Scripts” column, and can be re-used any time by selecting the file name.

MCP3423 Evaluation Board User's Guide

5. You can also see the SCL and SDA waveforms using the Oscilloscope.

Note: When you click on the “Execute Script” menu, the “Busy” LED on the PICkit Serial Analyzer will momentarily turn on and then turn off. If the LED remains ON, a communications problem has occurred. Remove the PICkit Serial Analyzer from your computer and recheck the parameter values including the order of parameters under the “Script Detail” column, and try again until the “Busy” LED turns OFF immediately after sending the I²C command.

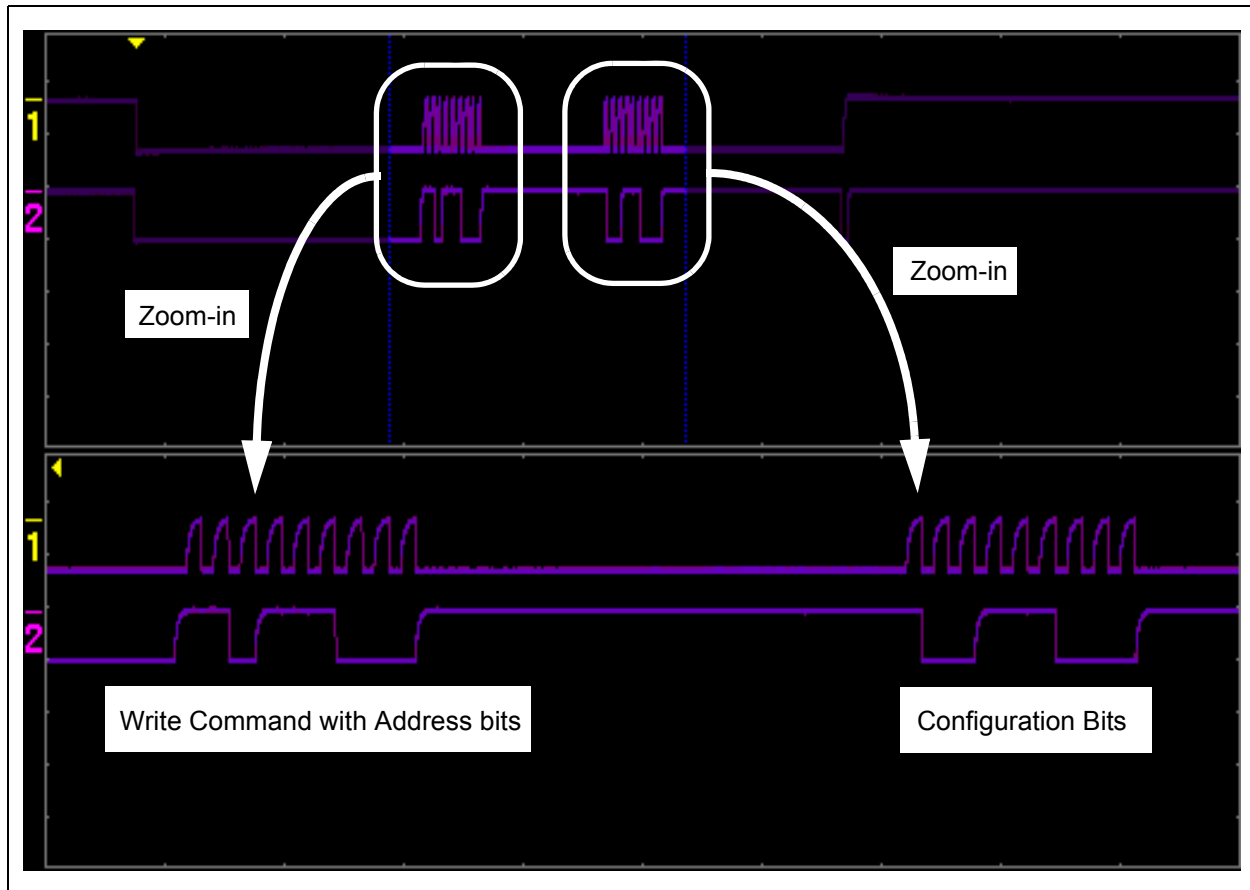

FIGURE 1-12: I²C Write Command Waveforms for the MCP3423.

1.3.3 Trouble Shooting: If the device does not acknowledge the commands

If the device is powered up initially with unstable V_{DD} from the PICKit Serial, there is a chance that the device can latch a wrong address bits from the external address pins, and therefore it may not acknowledge the command bytes correctly since the address bits are not matched. In this case, send a General Call Latch Command after the V_{DD} is stabilized (after about 20 seconds the PICKit Serial is powered). See the example in Figure 1-13. Another method is power-up the PICKit Serial first by connecting to the PC, then insert the MCP3423 EV board to the PICKit Serial about 20 seconds later.

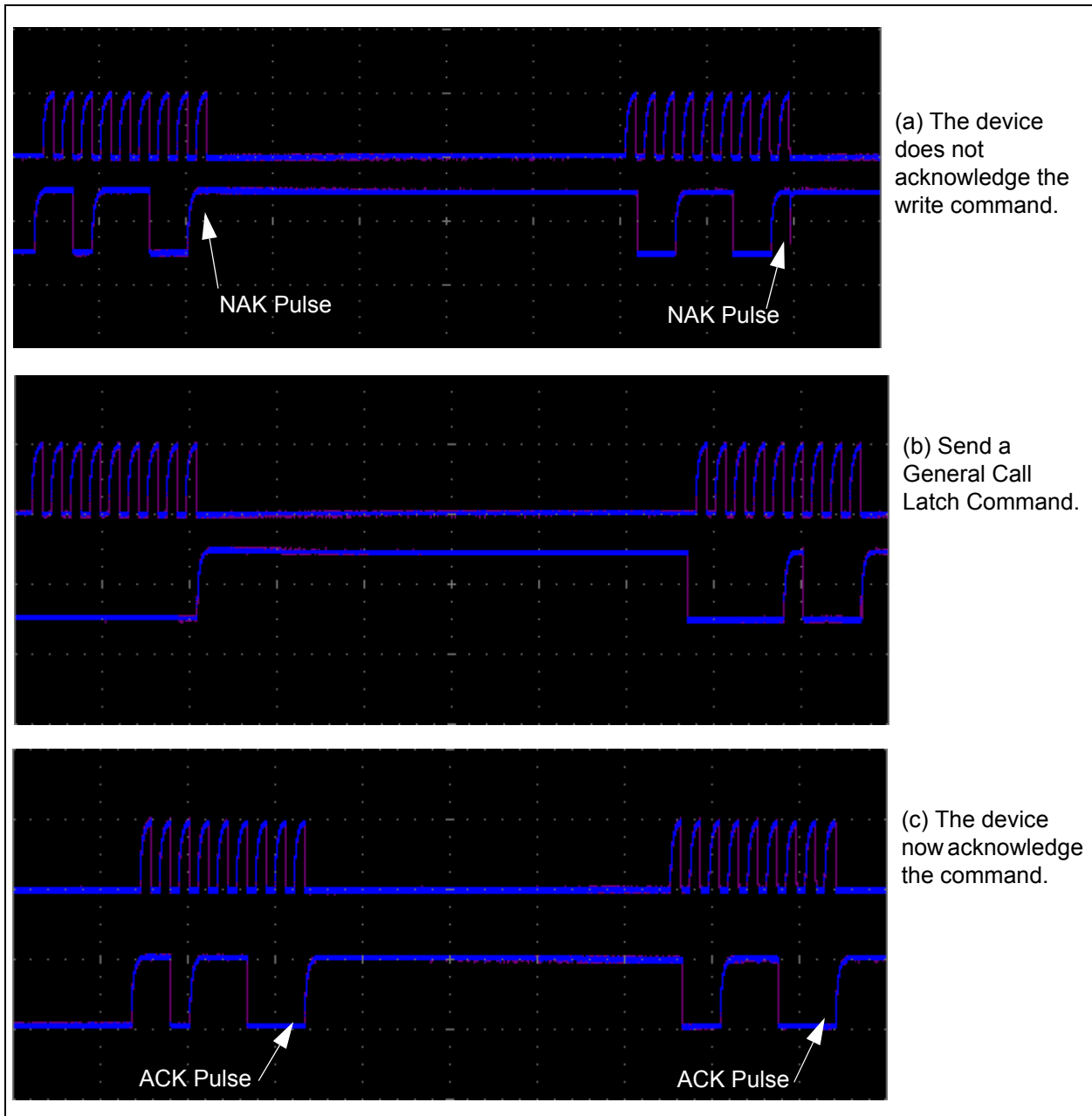

FIGURE 1-13: Examples when the device is not acknowledging the write command. Send the General Call Latch Command when the V_{DD} is stabilized.

MCP3423 Evaluation Board User's Guide

1.3.4 Reading the Conversion Data using the PICkit Serial Analyzer

You can read back the conversion data with the following steps.

1.3.4.1 CREATING SCRIPT FILE TO READ CONVERSION DATA

1. Click on **ReadAddrA8** in "Example I2C Scripts" column.

This will result in filling in the spaces under "Script Detail" column.

Now you can modify the parameter boxes (delete or insert) in the "Script Detail" column with options. The list of options will appear if you right-click the mouse in the parameter box. You can delete the parameter box or add a new one.

2. Make sure you have the "Script Detail" parameters listed in order as follows:

Script Detail	
I2CSTART	*
I2CWRTBYT	*
01	→ This means there is <u>one</u> byte for address
DD	→ Address byte with W/R bit = 1101-1101
I2CRDBYTNLB	*
5	→ 5 bytes to read
I2CSTOP	*

Note: All seven parameters above must be listed in order. The parameters above marked with * character are not modifiable.
Address bits (A2, A1, A0) = (1, 1, 0) if both JP2 and JP3 are tied to V_{DD} . You can use different address bits by rearranging the JP1 and JP2 connectors. See MCP3423 Data Sheet for more information on address bit selections.

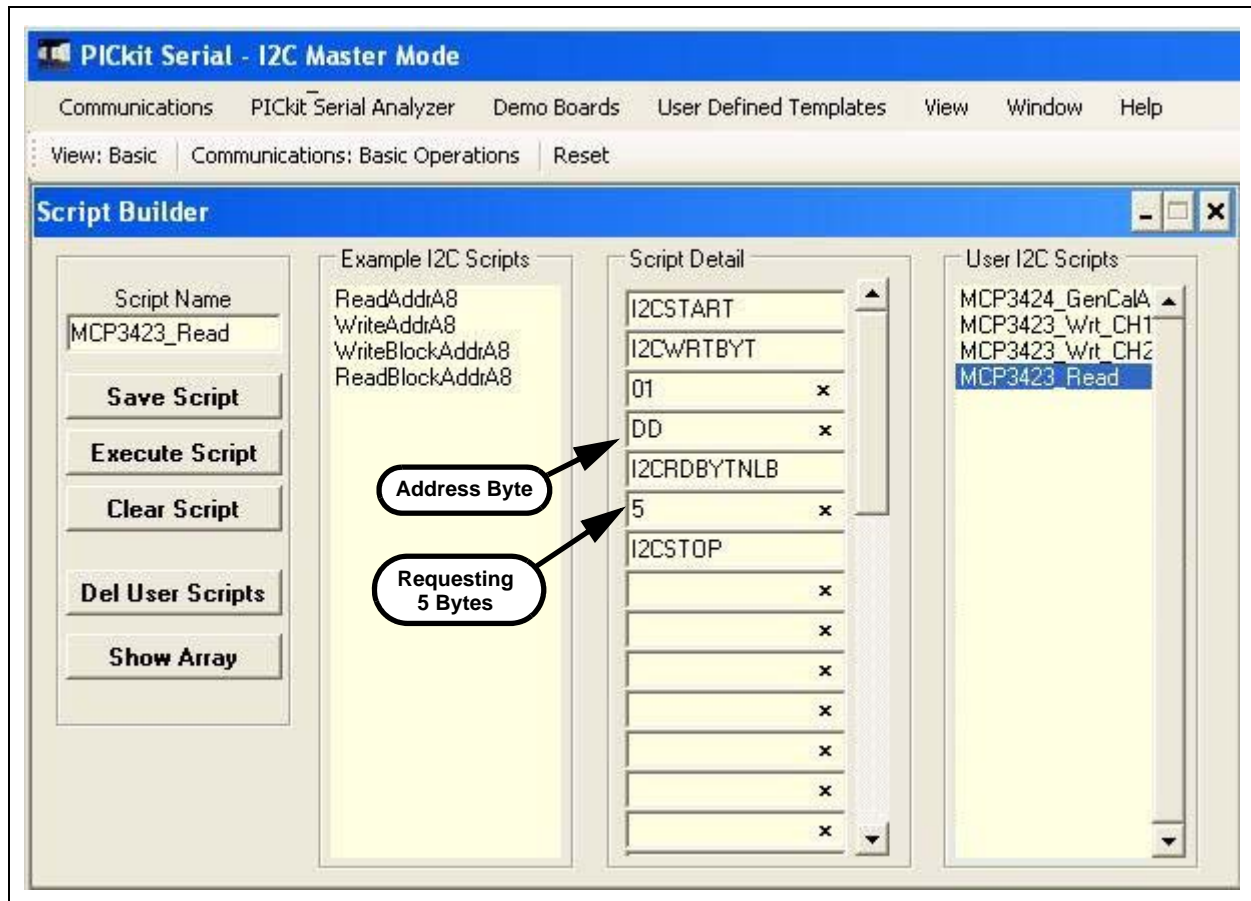

FIGURE 1-14: Script File sample to read conversion data.

3. Type in any script name (i.e., MCP3423_Read) in the space below the “Script Name” menu.
4. Click **Save Script** button.
5. Click **Execute Script** button.

Note: At this point, the PICKit Serial transmits the I²C Read Command to the MCP3423 device. The saved file name will appear in “Users I2C Scripts” column, and can be re-used any time by selecting the file name.

6. You can also see the SCL and SDA waveforms using the Oscilloscope.

Note: When you click on the “Execute Script” menu, the “Busy” LED on the PICKit Serial Analyzer will momentarily turn on and then turn off. If the LED remains ON, a communications problem has occurred. Remove the PICKit Serial Analyzer from your computer and recheck the parameter values including the order of parameters under the “Script Detail” column, and try again until the “Busy” LED turns OFF immediately after sending the I²C command.

MCP3423 Evaluation Board User's Guide

PICKit Serial - I2C Master Mode

Communications PICKit Serial Analyzer Demo Boards User Defined Templates View Window Help

View: Basic Communications: Basic Operations Reset

Script Builder

Script Name: MCP3423_Read

Save Script Execute Script Clear Script Del User Scripts Show Array

Example I2C Scripts: ReadAddrA8 WriteAddrA8 WriteBlockAddrA8 ReadBlockAddrA8

Script Detail:

I2CSTART	
I2CWRTBYT	
01	x
DD	x
I2CRDDBYTNLB	
5	x
I2CSTOP	
	x
	x
	x
	x
	x
	x

User I2C Scripts: MCP3424_GenCalA MCP3423_Wrt_CH1 MCP3423_Wrt_CH2 MCP3423_Read

Transactions

File Edit Clear

10:24:44 AM Sent script from Script Builder page, 10 bytes:

[S_] [W_] [01] [DD] [RN] [05] [P_] [S_] [00] [F9] [07] [1C] [9C] [P_]

Reading Data using a Read Command

5th byte: Repeated Byte for Configuration byte
 4th byte: Configuration Byte (note that RDYbit is "0")
 3rd byte: Data Byte
 2nd byte: Data Byte
 1st byte: Data Byte

Results:

Output code: F907 in hex (= 63751 in decimal)

Output Voltage= $63751 \times \frac{15.625 \mu\text{V (LSB)}}{\text{PGA}} = 0.996 \text{ Volts with PGA} = 1$

Note that if the differential input voltage is negative (CH- > CH+), the MSB of the first byte will be "1". In this case, the voltage is calculated after converting the output code to 2's complement and then multiply the LSB.
 See Section 4.9 of the MCP3423 Data Sheet (DS22088) for more information.

FIGURE 1-15: Reading Conversion Results: Note that the Input = 0.996V is applied to CH1. The reading indicates the measured value is 0.996 Volts.

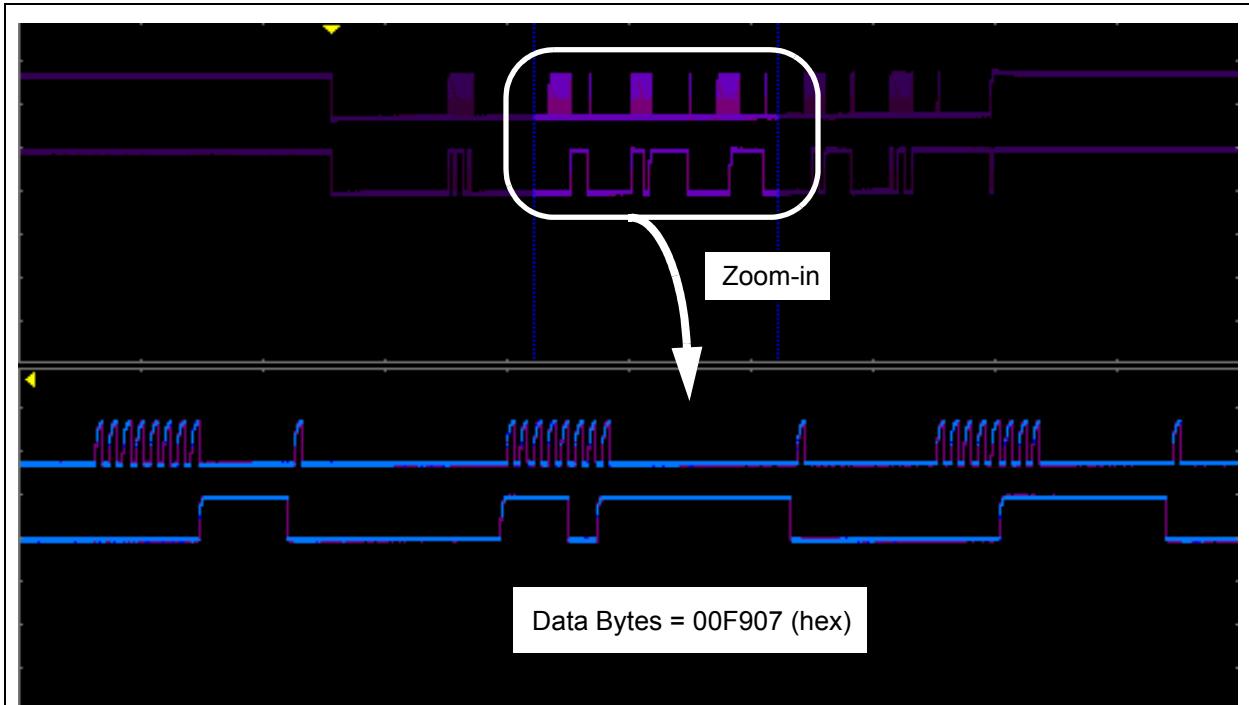

(a) Read command and outputs. The 3 data bytes are zoomed in for better clarity.

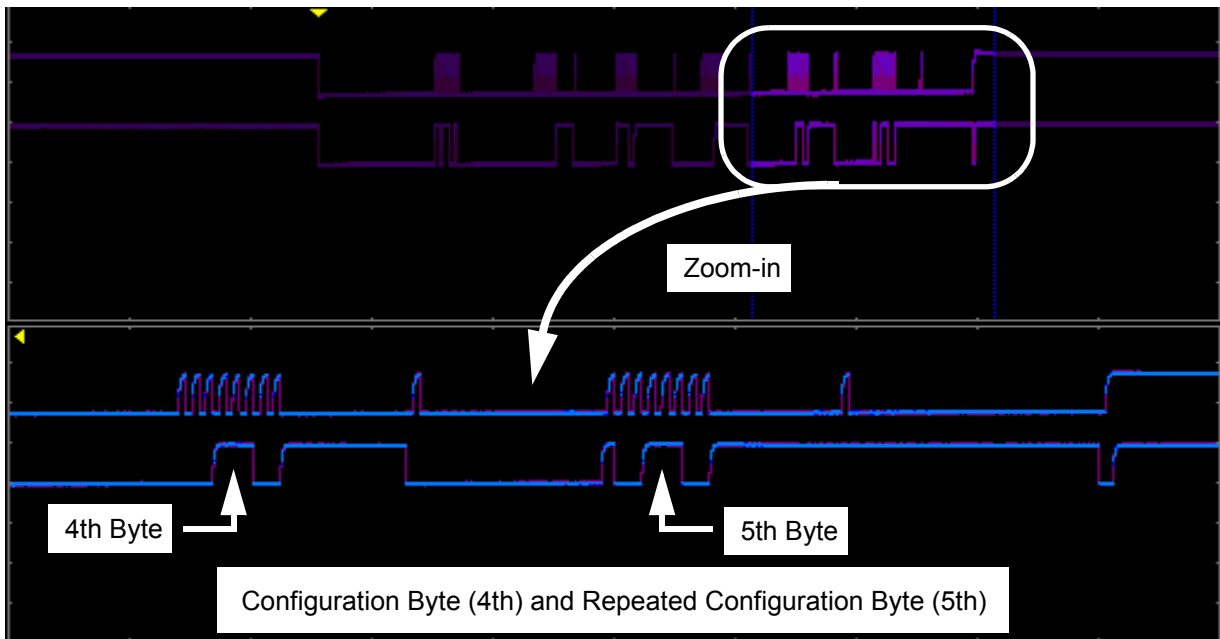

(b) Read command and outputs. The last two data bytes are zoomed in for better clarity.

FIGURE 1-16: Read Command and Data on I²C bus. Note the \overline{RDY} bit in 4th byte is "0". This means the conversion data just read is the latest conversion data. The \overline{RDY} bit becomes "1" in the 5th byte (repeated byte). This means the device is now in the process of new conversion and the new result is not ready yet.

1.4 EXPERIMENT FOR CH2

Repeat the instructions from **Section 1.3.2 “Creating Script Files”** to **Section 1.3.4 “Reading the Conversion Data using the PICKit Serial Analyzer”** for the input channel 2.



MCP3423 EVALUATION BOARD USER'S GUIDE

Appendix A. Schematic and Layouts

A.1 INTRODUCTION

This appendix contains the following schematics and layouts for the MCP3424 Evaluation Board:

- Board – Schematic
- Board – Top Layer
- Board – Top Metal Layer
- Board – Bottom Layer
- Board – Bottom Metal Layer

MCP3423 Evaluation Board User's Guide

A.2 BOARD – SCHEMATIC

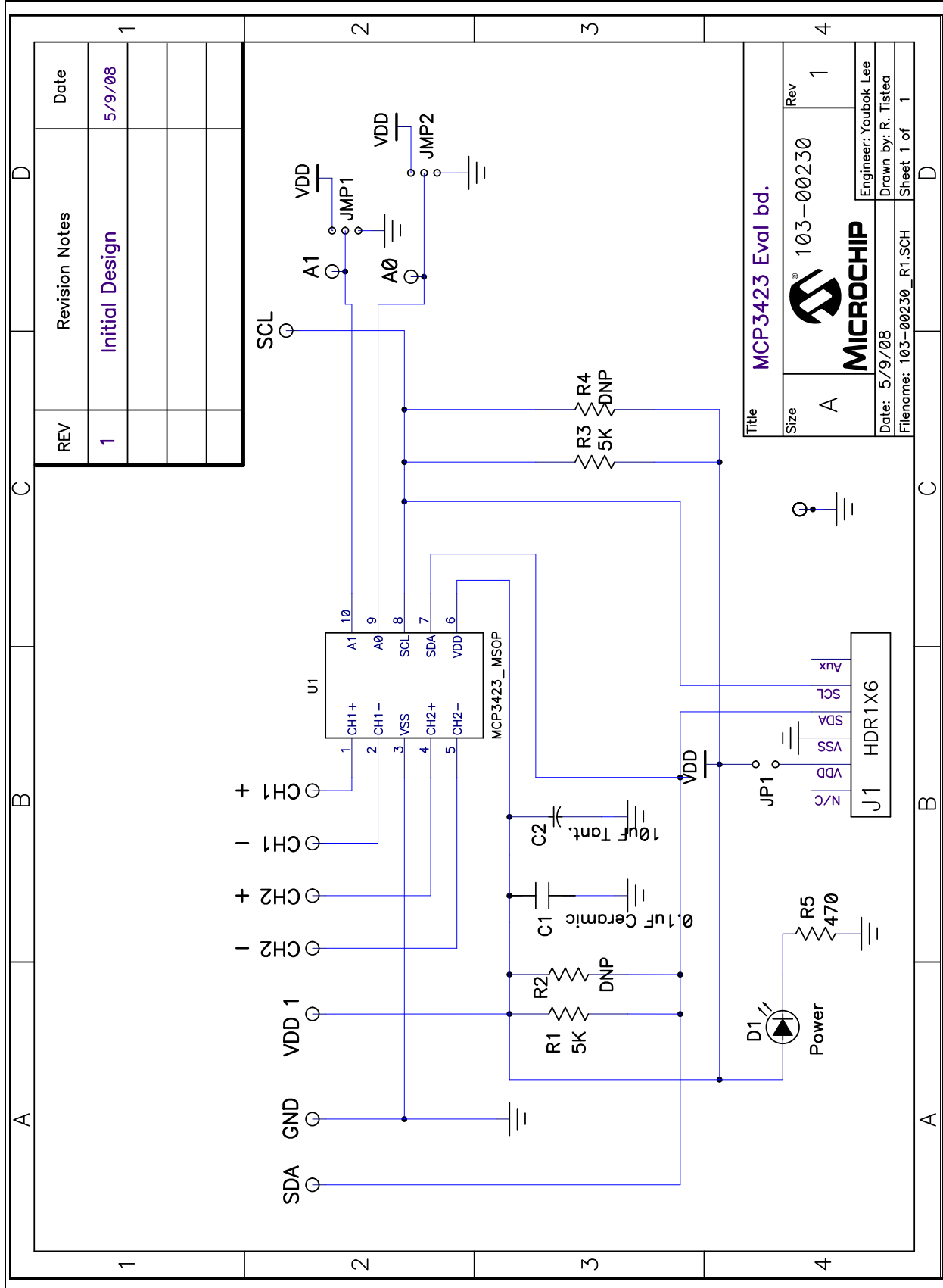

A.3 BOARD – TOP LAYER

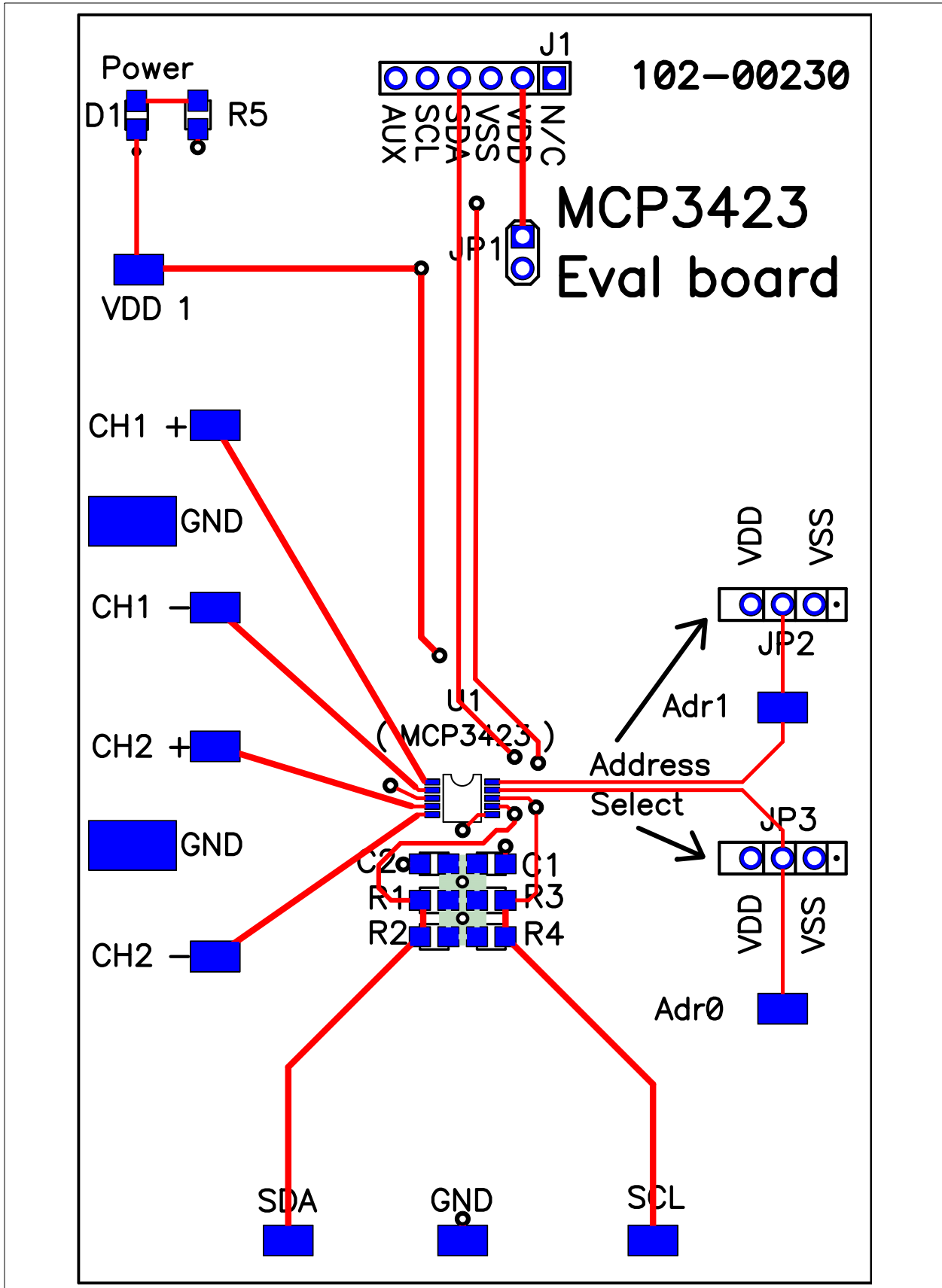

MCP3423 Evaluation Board User's Guide

A.4 BOARD – TOP METAL LAYER

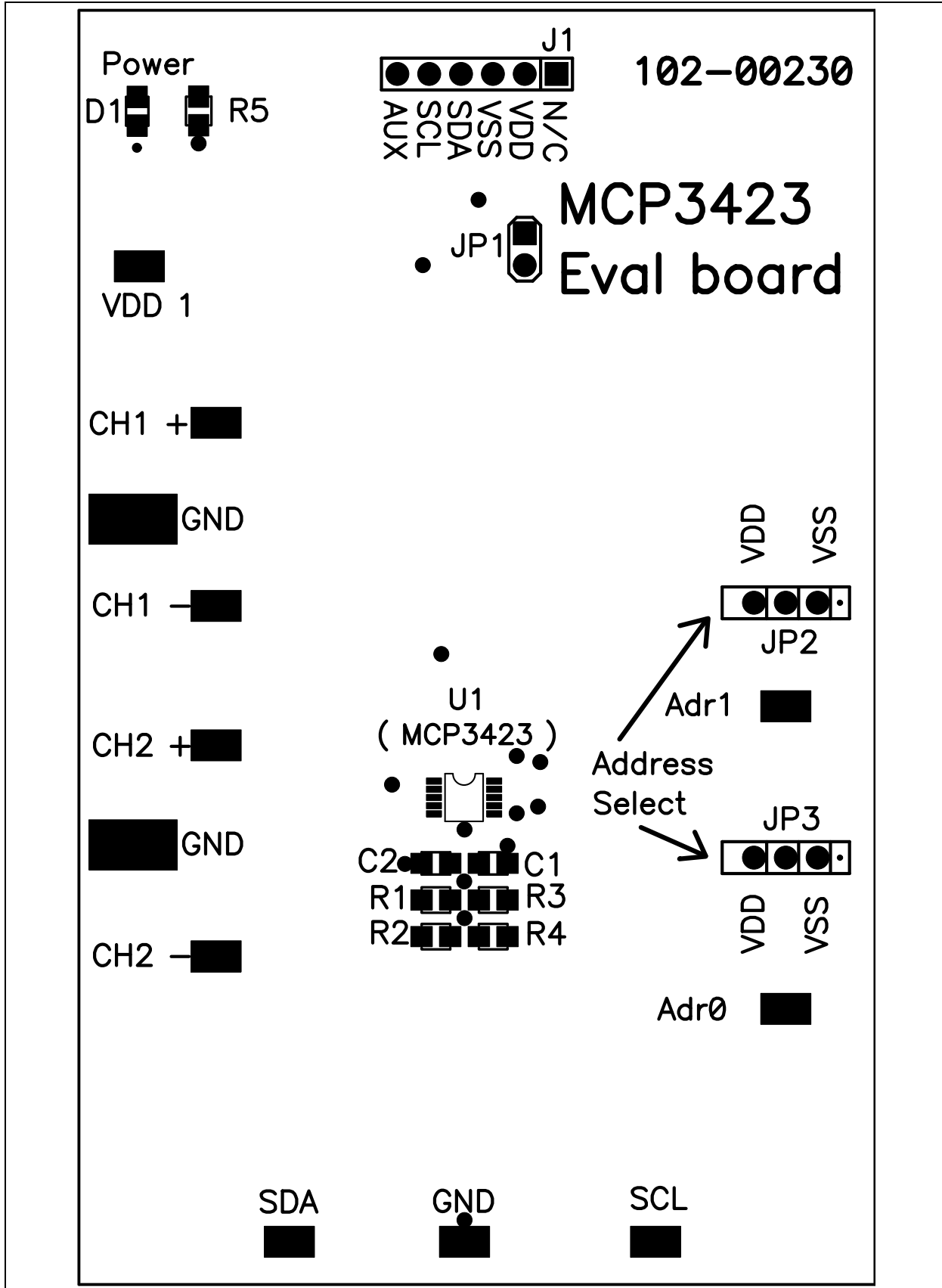

A.5 BOARD – BOTTOM LAYER

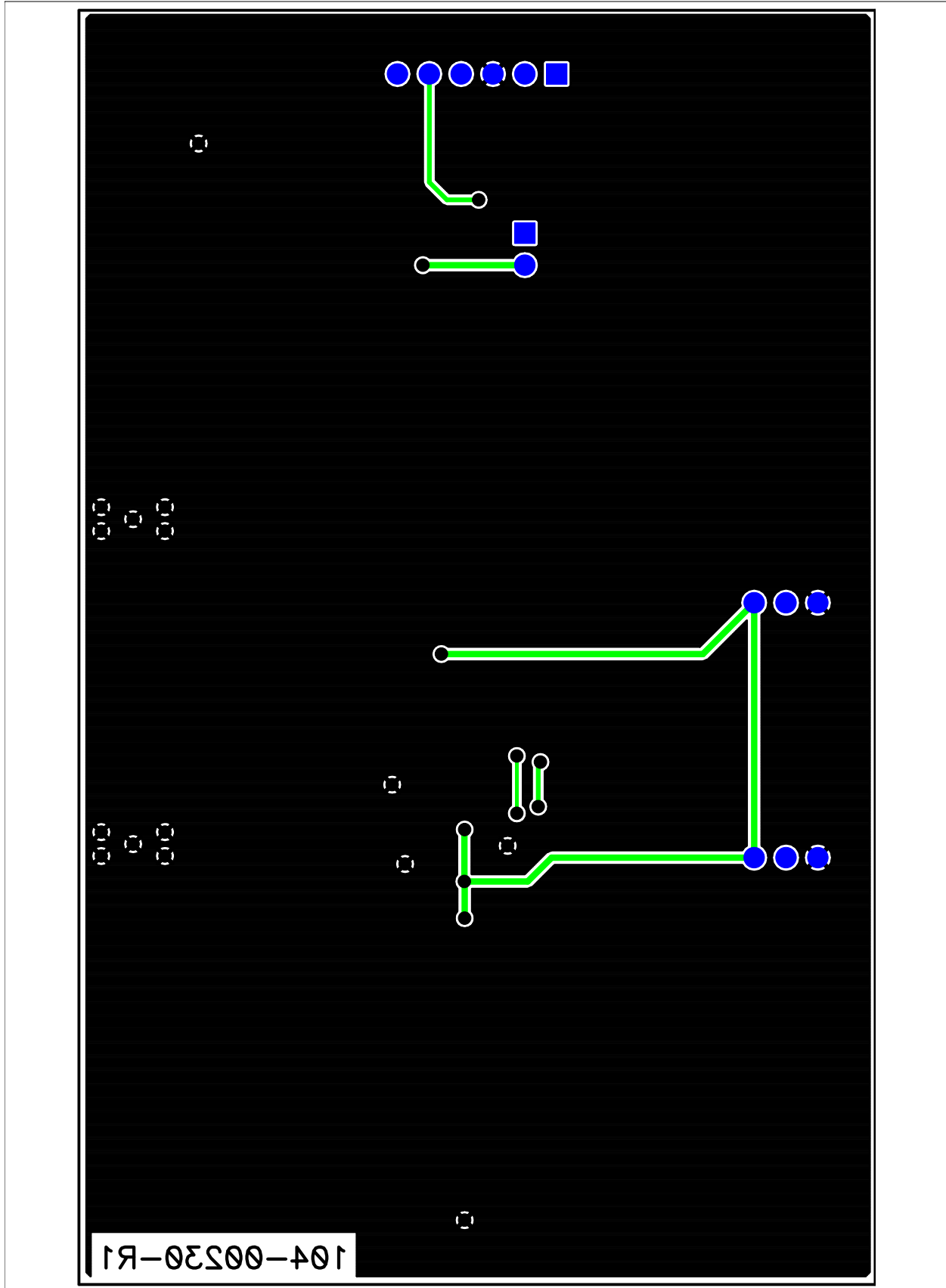

MCP3423 Evaluation Board User's Guide

A.6 BOARD – BOTTOM METAL LAYER

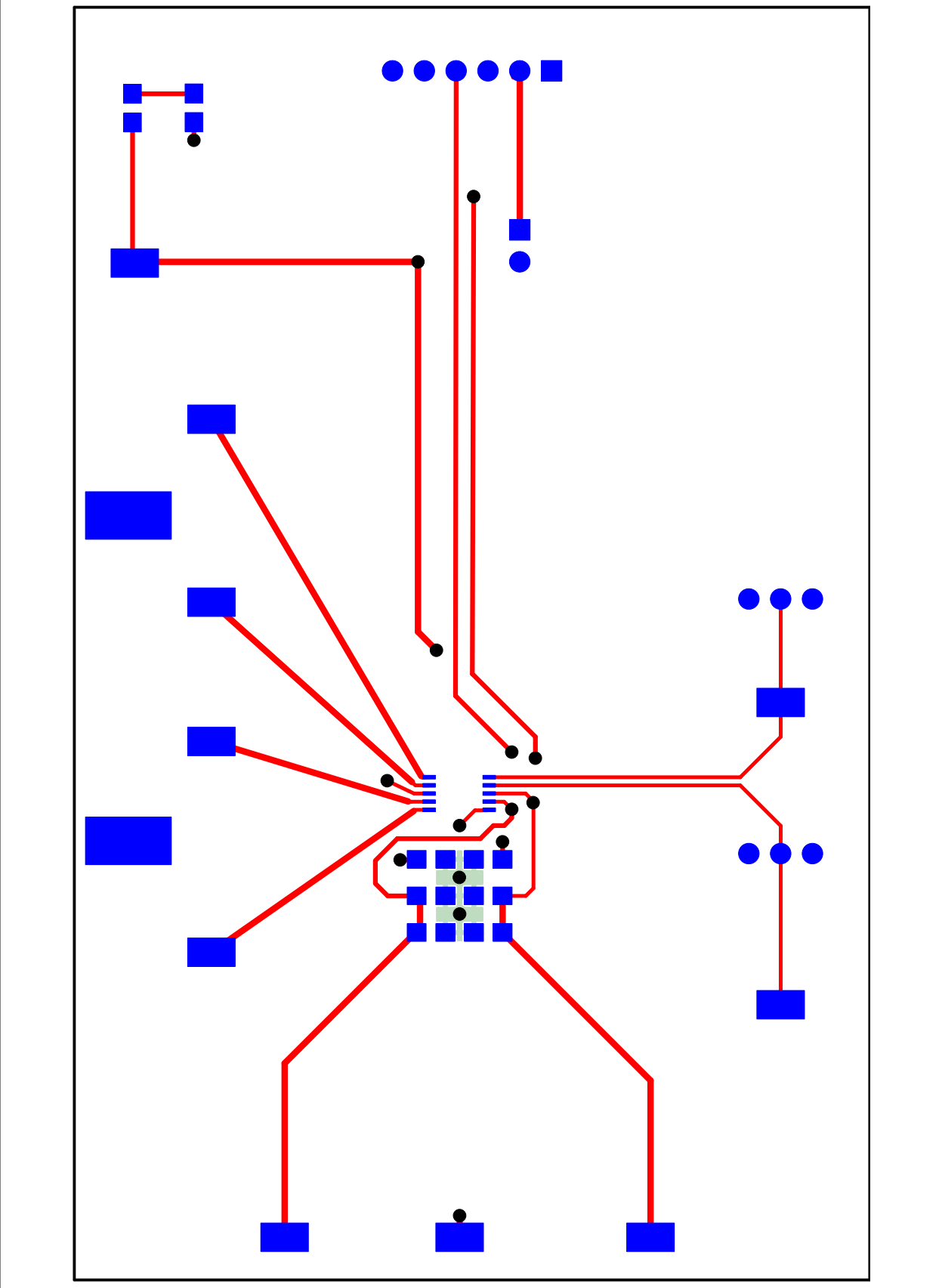

Appendix B. Bill of Materials (BOM)

TABLE B-1: BILL OF MATERIALS (BOM)

Qty	Reference	Description	Manufacturer	Part Number
1	C1	CAP .1UF 25V CERAMIC X7R 0805	Panasonic® - ECG	ECJ-2VB1E104K
1	C2	CAP CERAMIC 10UF 6.3V X5R 0805	Panasonic - ECG	ECJ-2FB0J106K
1	D1	LED RED ORANGE CLEAR 0805 SMD	LITE-ON INC	LTST-C170EKT
2	R1,R3	RES 4.99K OHM 1/8W 1% 0805 SMD	Panasonic - ECG	ERJ-6ENF4991V
1	R5	RES 470 OHM 1/8W 5% 0805 SMD	Panasonic - ECG	ERJ-6GEYJ471V
1	J1	CONN HEADER 6POS .100 R/A TIN	Molex®/ Waldom® Electronics	22-05-2061
1	JP1	CONN HEADER 2POS .100 VERT TIN	Molex/Waldom Electronics	22-03-2021
2	JP2,JP3	CONN HEADER 3POS .100" STR TIN	Molex/Waldom Electronics	90120-0123
1	PCB	RoHS Compliant Bare PCB, MCP3423 Evaluation Board for PICKit Serial	Microchip Technology Inc.	104-00230
3	Shunts for JP1, JP2, JP3	100" Shorting Block with Handle	JAMECO Value-Pro	2012JH-R
2	R2,R4	DO NOT POPULATE	—	—
1	U1	2 Channel 18 Bit Data Sigma ADC	Microchip Technology Inc.	MCP3423-E/ST
14	VDD1, CH1+, CH1-, CH2+, CH2-, A0, A1, SCL, SDA, GND	TEST POINT PC COMPACT SMT	Keystone Electronics®	5016

Note 1: The components listed in this Bill of Materials are representative of the PCB assembly. The released BOM used in manufacturing uses all RoHS-compliant components.



WORLDWIDE SALES AND SERVICE

AMERICAS

Corporate Office
2355 West Chandler Blvd.
Chandler, AZ 85224-6199
Tel: 480-792-7200
Fax: 480-792-7277
Technical Support:
<http://support.microchip.com>
Web Address:
www.microchip.com

Atlanta
Duluth, GA
Tel: 678-957-9614
Fax: 678-957-1455

Boston
Westborough, MA
Tel: 774-760-0087
Fax: 774-760-0088

Chicago
Itasca, IL
Tel: 630-285-0071
Fax: 630-285-0075

Dallas
Addison, TX
Tel: 972-818-7423
Fax: 972-818-2924

Detroit
Farmington Hills, MI
Tel: 248-538-2250
Fax: 248-538-2260

Kokomo
Kokomo, IN
Tel: 765-864-8360
Fax: 765-864-8387

Los Angeles
Mission Viejo, CA
Tel: 949-462-9523
Fax: 949-462-9608

Santa Clara
Santa Clara, CA
Tel: 408-961-6444
Fax: 408-961-6445

Toronto
Mississauga, Ontario,
Canada
Tel: 905-673-0699
Fax: 905-673-6509

ASIA/PACIFIC

Asia Pacific Office
Suites 3707-14, 37th Floor
Tower 6, The Gateway
Harbour City, Kowloon
Hong Kong
Tel: 852-2401-1200
Fax: 852-2401-3431

Australia - Sydney
Tel: 61-2-9868-6733
Fax: 61-2-9868-6755

China - Beijing
Tel: 86-10-8528-2100
Fax: 86-10-8528-2104

China - Chengdu
Tel: 86-28-8665-5511
Fax: 86-28-8665-7889

China - Hong Kong SAR
Tel: 852-2401-1200
Fax: 852-2401-3431

China - Nanjing
Tel: 86-25-8473-2460
Fax: 86-25-8473-2470

China - Qingdao
Tel: 86-532-8502-7355
Fax: 86-532-8502-7205

China - Shanghai
Tel: 86-21-5407-5533
Fax: 86-21-5407-5066

China - Shenyang
Tel: 86-24-2334-2829
Fax: 86-24-2334-2393

China - Shenzhen
Tel: 86-755-8203-2660
Fax: 86-755-8203-1760

China - Wuhan
Tel: 86-27-5980-5300
Fax: 86-27-5980-5118

China - Xiamen
Tel: 86-592-2388138
Fax: 86-592-2388130

China - Xian
Tel: 86-29-8833-7252
Fax: 86-29-8833-7256

China - Zhuhai
Tel: 86-756-3210040
Fax: 86-756-3210049

ASIA/PACIFIC

India - Bangalore
Tel: 91-80-4182-8400
Fax: 91-80-4182-8422

India - New Delhi
Tel: 91-11-4160-8631
Fax: 91-11-4160-8632

India - Pune
Tel: 91-20-2566-1512
Fax: 91-20-2566-1513

Japan - Yokohama
Tel: 81-45-471- 6166
Fax: 81-45-471-6122

Korea - Daegu
Tel: 82-53-744-4301
Fax: 82-53-744-4302

Korea - Seoul
Tel: 82-2-554-7200
Fax: 82-2-558-5932 or
82-2-558-5934

Malaysia - Kuala Lumpur
Tel: 60-3-6201-9857
Fax: 60-3-6201-9859

Malaysia - Penang
Tel: 60-4-227-8870
Fax: 60-4-227-4068

Philippines - Manila
Tel: 63-2-634-9065
Fax: 63-2-634-9069

Singapore
Tel: 65-6334-8870
Fax: 65-6334-8850

Taiwan - Hsin Chu
Tel: 886-3-572-9526
Fax: 886-3-572-6459

Taiwan - Kaohsiung
Tel: 886-7-536-4818
Fax: 886-7-536-4803

Taiwan - Taipei
Tel: 886-2-2500-6610
Fax: 886-2-2508-0102

Thailand - Bangkok
Tel: 66-2-694-1351
Fax: 66-2-694-1350

EUROPE

Austria - Wels
Tel: 43-7242-2244-39
Fax: 43-7242-2244-393

Denmark - Copenhagen
Tel: 45-4450-2828
Fax: 45-4485-2829

France - Paris
Tel: 33-1-69-53-63-20
Fax: 33-1-69-30-90-79

Germany - Munich
Tel: 49-89-627-144-0
Fax: 49-89-627-144-44

Italy - Milan
Tel: 39-0331-742611
Fax: 39-0331-466781

Netherlands - Drunen
Tel: 31-416-690399
Fax: 31-416-690340

Spain - Madrid
Tel: 34-91-708-08-90
Fax: 34-91-708-08-91

UK - Wokingham
Tel: 44-118-921-5869
Fax: 44-118-921-5820

Данный компонент на территории Российской Федерации

Вы можете приобрести в компании MosChip.

Для оперативного оформления запроса Вам необходимо перейти по данной ссылке:

<http://moschip.ru/get-element>

Вы можете разместить у нас заказ для любого Вашего проекта, будь то серийное производство или разработка единичного прибора.

В нашем ассортименте представлены ведущие мировые производители активных и пассивных электронных компонентов.

Нашей специализацией является поставка электронной компонентной базы двойного назначения, продукции таких производителей как XILINX, Intel (ex.ALTERA), Vicor, Microchip, Texas Instruments, Analog Devices, Mini-Circuits, Amphenol, Glenair.

Сотрудничество с глобальными дистрибьюторами электронных компонентов, предоставляет возможность заказывать и получать с международных складов практически любой перечень компонентов в оптимальные для Вас сроки.

На всех этапах разработки и производства наши партнеры могут получить квалифицированную поддержку опытных инженеров.

Система менеджмента качества компании отвечает требованиям в соответствии с ГОСТ Р ИСО 9001, ГОСТ РВ 0015-002 и ЭС РД 009

Офис по работе с юридическими лицами:

105318, г.Москва, ул.Щербаковская д.3, офис 1107, 1118, ДЦ «Щербаковский»

Телефон: +7 495 668-12-70 (многоканальный)

Факс: +7 495 668-12-70 (доб.304)

E-mail: info@moschip.ru

Skype отдела продаж:

moschip.ru

moschip.ru_4

moschip.ru_6

moschip.ru_9